

**Evaluation of Circulation Paths in Public Buildings in terms
of Accessibility: Re-functioned Public Historic Buildings in
the Nicosia Walled City**

Şüküfe Kocabaş

Submitted to the
Institute of Graduate Studies and Research
in partial fulfilment of the requirements for the Degree of

Master of Science
in
Interior Architecture

Eastern Mediterranean University
February 2013
Gazimağusa, North Cyprus

Approval of the Institute of Graduate Studies and Research

Prof. Dr. Elvan Yılmaz
Director

I certify that this thesis satisfies the requirements as a thesis for the degree of Master of Science in Interior Architecture.

Assoc. Prof. Dr. Uğur Ulaş Dağlı
Chair, Department of Interior Architecture

We certify that we have read this thesis and that in our opinion it is fully adequate in scope and quality as a thesis for the degree of Master of Science in Interior Architecture.

Dr. Betül Bilge
Co - Supervisor

Assoc. Prof. Dr. Özlem Olgaç Türker
Supervisor

Examining Committee

1. Assoc. Prof. Dr. Özlem Olgaç Türker

2. Asst. Prof. Dr. Guita Farivarsadri

3. Asst. Prof. Dr. Kağan Günçe

4. Asst. Prof. Dr. Nazife Özay

5. Dr. Betül Bilge

ABSTRACT

All users have equal rights to contribute social activities. However, the built environment creates obstacles for people. Especially, people with physical disabilities have various difficulties about accessibility. Accessibility problem, which is the result of unconscious structuring of built environment, is the main point of the study.

Accessibility problem has been attempted more deeply throughout the developed countries. Many guidelines and concepts have been formed about accessibility in developed countries. With regulations and approaches that have been done, accessibility standards ease the life of people living in these countries. However, this sensitivity about design of the built environment is not sufficiently taken into consideration in North Cyprus. There are many historical public buildings in Nicosia, which is the capital city of North Cyprus. These buildings are in the Walled City, especially on the "walking route" which is defined by the Ministry of Tourism, Environment and Culture. Unfortunately, disabled people (local or tourists), generally have limited access to these public historic buildings. The Walled City is the point of intersection of many civilizations, which hosted historic public buildings that are generally re-functioned. In this context, for the diversity of user profile, both local residents and tourists, it is expected to provide barrier-free access to public buildings that are re-functioned with cultural functions.

Objective of this study is to analyse the accessibility standards for public buildings and specify accessibility standards of horizontal and vertical circulations in

the public buildings. The other target is to present existing accessibility conditions of the public historic buildings on the "walking route" in the Walled City.

In this study, public historic buildings, which have cultural functions are selected, and components of circulation are analysed in terms of accessibility. Especially, horizontal and vertical circulations of spaces, which are closed, semi-open, defined open and open, are examined in terms of examined international accessibility standards.

Keywords: Interior design, accessibility, circulation, public historic buildings, Nicosia Walled City

ÖZ

Tüm kullanıcılar sosyal faaliyetlere katılmak konusunda eşit haklara sahiptirler. Ancak, yapısal çevre insanlar için engel oluşturmaktadır. Özellikle fiziksel açıdan erişilebilirlik sorunu yaşayan engelli kişiler, çeşitli zorluklarla karşılaşmaktadırlar. Çalışmada üzerinde durulan esas nokta, bilinçsiz yapılaşma sonucu ortaya çıkan erişilebilirlik problemidir.

Erişilebilirlik sorunu, gelişmiş ülkelerin genelinde daha detaylı bir biçimde ele alınmaktadır. Erişilebilirlik hakkındaki birçok kural ve kavram, gelişmiş ülkeler tarafından oluşturulmuştur. Yapılan düzenlemeler ve yaklaşımlarla, erişilebilirlik standartları, bu ülkelerde yaşayan insanların hayatını kolaylaştırmaktadır. Buna karşın, yapısal çevre tasarımıyönelik geliştirilen bu duyarlılık, Kuzey Kıbrıs'ta yeteri kadar dikkate alınmamaktadır.

Kuzey Kıbrıs'ın başkenti olan Lefkoşa'da birçok tarihi kamusal bina bulunmaktadır. Bu binalar, özellikle Suriçi'nde Turizm, Çevre ve Kültür Bakanlığı tarafından tanımlanan bir "yürüyüş yolu" üzerinde yer almaktadırlar. Ne yazık ki, engelli bireylerin (yerel ya da turist), bu kamusal tarihi binalara erişimi genellikle sınırlı olmaktadır. Birçok medeniyetin kesişim noktası olma özelliğini taşıyan Lefkoşa Suriçi'nin barındırdığı tarihi kamusal binaların birçoğu yeniden işlevlendirilmiştir. Bu bağlamda çeşitlilik gösteren, hem yerel halk hem de turistlerden oluşan kullanıcı profiline yönelik olarak kültürel fonksiyonlarla yeniden işlevlendirilmiş binalara engelsiz erişim olanağı sağlanmalıdır.

Bu çalışmanın amacı, kamu binalarına yönelik erişilebilirlik standartlarını incelemek ve bu binalarda yatay ve dikey sirkülasyona göre erişilebilirlik standartlarını belirtmektir. Diğer hedef, Surlarıçindeki "yürüyüş yolu" üzerindeki kamusal tarihi binaların varolan erişilebilirlik durumlarını ortaya koymaktır.

Bu çalışmada kültürel işlevi olan, farklı fonksiyonlarla kullanılan, kamusal tarihi binalar seçilmiş ve binaların sirkülasyon bileşenleri erişilebilirlik açısından incelenmiştir. Özellikle, yarı açık, açık, tanımlı açık ve kapalı alanlarda yatay ve dikey sirkülasyon, incelenen uluslararası erişilebilirlik standartları açısından değerlendirilmiştir.

Anahtar kelimeler: İç mekan tasarımı, erişilebilirlik, sirkülasyon, kamusal tarihi binalar, Lefkoşa Suriçi

TO WONDERFUL QUARTET OF MY LIFE,

AND TO MY LIGHT ŐUKÜFE ATAKANLI...

ACKNOWLEDGMENTS

I would initially like to express my sincere gratitude to my supervisors Assoc. Prof. Dr. Özlem Olgaç Türker and Dr. Betül Bilge for their vast knowledge and invaluable feedbacks. They are really with me with their friendship, and they always trust in me during my study. This thesis would not have been completed without their supports.

I would like to express my deepest gratitude to my parents, Nadir and Mustafa Kocabaş, for believing me and for encouraging me throughout my life. Also, I am thankful to my sister, Ayşenur Kocabaş for being with me during the stressful process and for supporting me always when I feel desperate.

I would like to express my greatest debt and gratitude to my dear fiancé, Rifat Demiray who guided me with his wisdom, and always stood by me with his support.

I have done it better with all of you, thank you all.

TABLE OF CONTENTS

| | |
|--|------|
| ABSTRACT | iii |
| ÖZ | v |
| DEDICATION | vii |
| ACKNOWLEDGMENT..... | viii |
| LIST OF TABLES..... | xiv |
| LIST OF FIGURES | xv |
| 1 INTRODUCTION..... | 1 |
| 1.1 Description of the Thesis | 1 |
| 1.2 Accessibility Conditions in North Cyprus | 2 |
| 1.3 Problem Statement | 3 |
| 1.4 Purpose of the Study | 4 |
| 1.5 Methodology..... | 4 |
| 1.6 Limitations of the Study..... | 5 |
| 1.7 Definitions about disability..... | 6 |
| 1.8 Re-Functioned Historic Buildings & Accessibility | 7 |
| 2 SIGNIFICANCE OF ACCESSIBILITY..... | 13 |
| 2.1 Understanding Accessibility..... | 14 |
| 2.2 Approaches about Accessibility..... | 18 |
| 2.2.1 Barrier Free Design | 19 |
| 2.2.2 Universal Design | 20 |
| 2.2.3 Inclusive Design..... | 23 |
| 2.3 Acts and Organizations about Accessibility..... | 25 |
| 2.3.1 American Accessibility Standards (ADA) | 25 |

| | |
|---|-----------|
| 2.3.2 World Report on Disability..... | 26 |
| 2.3.3 UFAS Retrofit Guide | 28 |
| 2.3.4 The European Disability Forum (EDF)..... | 29 |
| 2.4 Definitions and limitation | 30 |
| 2.5 Evaluation of the chapter..... | 30 |
| 3 ACCESSIBILITY STANDARDS FOR THE CIRCULATION PATHS IN PUBLIC BUILDINGS | 32 |
| 3.1 Components of Circulation Paths in Public Buildings..... | 33 |
| 3.1.1 Horizontal Circulation | 34 |
| 3.1.1.1 Parking Spaces | 34 |
| 3.1.1.2 Pavements | 35 |
| 3.1.1.3 Main Entrances | 37 |
| 3.1.1.4 Entrance Halls | 40 |
| 3.1.1.5 Corridors..... | 42 |
| 3.1.1.6 Doors and Passageways..... | 45 |
| 3.1.2 Vertical Circulation..... | 49 |
| 3.1.2.1 Steps and Stairs | 50 |
| 3.1.2.2 Ramps..... | 54 |
| 3.1.2.3Lifts..... | 57 |
| 3.2 Categories of Circulation Paths in Public Buildings..... | 61 |
| 3.3 Evaluation of the Chapter | 63 |
| 4 EVALUATION OF ACCESSIBILITY IN SELECTED BUILDINGS IN NICOSIA WALLED CITY | 67 |
| 4.1 Analyses of Mevlevi Tekke Museum According to Accessibility Standards..... | 73 |

| | |
|---|-----|
| 4.1.1 Analyses of Circulation Paths of Outdoor Spaces Related with Entrances | 73 |
| 4.1.2 Analyses of Circulation Paths of Semi-Open Spaces | 75 |
| 4.1.3 Analyses of Circulation Paths of Indoor Spaces..... | 75 |
| 4.1.4 Analyses of Circulation Paths of Defined Open Spaces..... | 78 |
| 4.2 Analysis of Arabahmet Culture House According to Accessibility Standards | 83 |
| 4.2.1 Analyses of Circulation Paths of Outdoor Spaces Related with Entrances..... | 83 |
| 4.2.2 Analyses of Circulation Paths of Semi-Open Spaces..... | 85 |
| 4.2.3 Analyses of Circulation Paths of Indoor Spaces..... | 87 |
| 4.2.4 Analyses of Circulation Paths of Defined Open Spaces..... | 89 |
| 4.3 Analyses of Armenian Church According to Accessibility Standards..... | 91 |
| 4.4 Analyses of Dervish Pasha Mansion According to Accessibility Standards | 93 |
| 4.4.1 Analyses of Circulation Paths of Outdoor Spaces Related with Entrances | 93 |
| 4.4.2 Analyses of Circulation Paths of Semi-Open Spaces..... | 94 |
| 4.4.3 Analyses of Circulation Paths of Indoor Spaces..... | 97 |
| 4.4.4 Analyses of Circulation Paths of Defined Open Spaces..... | 99 |
| 4.5 Analyses of Great Hamam According to Accessibility Standards..... | 100 |
| 4.6 Analyses of Great Khan According to Accessibility Standards..... | 102 |
| 4.6.1 Analyses of Circulation Paths of Outdoor Spaces Related with Entrances | 102 |

| | |
|---|-----|
| 4.6.2 Analyses of Circulation Paths of Semi-Open Spaces..... | 104 |
| 4.6.3Analyses of Circulation Paths ofIndoor Spaces..... | 106 |
| 4.6.4 Analyses of Circulation Paths of Defined Open Spaces..... | 107 |
| 4.7Analyses of Bedesten According to Accessibility Standards | 110 |
| 4.7.1 Analyses of Circulation Paths of Outdoor Spaces Related with Entrances | 110 |
| 4.7.2 Analyses of Circulation Paths of Semi-Open Spaces..... | 112 |
| 4.7.3 Analyses of Circulation Paths ofIndoor Spaces..... | 114 |
| 4.7.4 Analyses of Circulation Paths of Defined Open Spaces..... | 116 |
| 4.8 Analyses of The Eaved House According to Accessibility Standards... | 120 |
| 4.8.1 Analyses of Circulation Paths of Outdoor Spaces Related with Entrances | 120 |
| 4.8.2 Analyses of Circulation Paths of Semi-Open Spaces..... | 122 |
| 4.8.3 Analyses of Circulation Paths ofIndoor Spaces..... | 124 |
| 4.8.4 Analyses of Circulation Paths of Defined Open Spaces..... | 125 |
| 4.9Analyses of Lapidary Museum According to Accessibility Standards.. | 128 |
| 4.9.1 Analyses of Circulation Paths of Outdoor Spaces Related with Entrances | 128 |
| 4.9.2 Analyses of Circulation Paths of Semi-Open Spaces | 129 |
| 4.9.3Analyses of Circulation Paths ofIndoor Spaces..... | 129 |
| 4.9.4 Analyses of Circulation Paths of Defined Open Spaces..... | 131 |
| 4.10 Analyses of Lusignan House According to Accessibility Standards ... | 134 |
| 4.10.1 Analyses of Circulation Paths of Outdoor Spaces Related with Entrances..... | 134 |
| 4.10.2 Analyses of Circulation Paths of Semi-Open Spaces..... | 135 |

| | |
|---|-----|
| 4.10.3 Analyses of Circulation Paths of Indoor Spaces..... | 138 |
| 4.10.4 Analyses of Circulation Paths of Defined Open Spaces | 139 |
| 4.11 General Evaluation of Selected Buildings | 142 |
| 5 CONCLUSIONS | 145 |
| REFERENCES | 148 |

LIST OF TABLES

| | |
|--|-----|
| Table 1: Evolution of accessibility..... | 17 |
| Table 2: Principles of Universal Design..... | 22 |
| Table 3: From ‘Special Needs’ to ‘Inclusive Design’ | 24 |
| Table 4: Principles of Inclusive Design..... | 24 |
| Table 5: Types of lifts..... | 57 |
| Table 6: Analysis table for selected buildings..... | 65 |
| Table 7: Table showing the measurements for evaluation of horizontal & vertical circulation components in terms of accessibility..... | 66 |
| Table 8: General information on case – studies..... | 69 |
| Table 9: Analysis of Mevlevi Tekke Museum..... | 82 |
| Table 10: Analysis of Arabahmet Culture House..... | 92 |
| Table 11: Analysis of Dervish Pasha Mansion..... | 101 |
| Table 12: Analysis of Great Khan..... | 109 |
| Table 13: Analysis of Bedesten..... | 119 |
| Table 14: Analysis of the Eaved House..... | 127 |
| Table 15: Analysis of Lapidary Museum..... | 133 |
| Table 16: Analysis of Lusignan House..... | 141 |
| Table 17: Analysis matrix of the buildings..... | 143 |
| Table 18: Bar Charts of Analysis..... | 144 |

LIST OF FIGURES

| | |
|---|----|
| Figure 1: Retractable access lift, Bode Museum, Berlin..... | 9 |
| Figure 2: Through floor lifts, Bode Museum, Berlin. | 9 |
| Figure 3: Stair Wheelchair Platform Lift, Bode Museum, Berlin..... | 10 |
| Figure 4: Adapted passenger lift, Philharmonie, The Netherlands. | 11 |
| Figure 5: Alternative entrance at basement, Queen’s House, Greenwich..... | 12 |
| Figure 6: A kind of mobility experience of person with stroller..... | 15 |
| Figure 7: A kind of obstacle in front of the disabled people..... | 15 |
| Figure 8: An accessible toilet example. | 20 |
| Figure 9: Car parking area near the entrance. | 35 |
| Figure 10: Car parking area near the entrance. | 35 |
| Figure 11: Pavement dimensions. | 36 |
| Figure 12: Passing places of pavements..... | 37 |
| Figure 13: Canopy example for entrances. | 38 |
| Figure 14: Manoeuvring clearances at manual swinging doors and gates..... | 39 |
| Figure 15: Manoeuvring clearances at doorways without doors, sliding doors, gates, and folding doors. | 39 |
| Figure 16: Manoeuvring clearances at doorways without doors, sliding doors, gates, and folding doors. | 39 |
| Figure 17: Doors and gates in series. | 39 |
| Figure 18: Entrance hall plan view. | 40 |
| Figure 19: Entrance hall. | 41 |
| Figure 20: Necessary space for wheelchair user and assistant..... | 41 |

| | |
|--|----|
| Figure 21: Accessible entrance hall. | 42 |
| Figure 22: Corridor widths..... | 43 |
| Figure 23: Dimension of wheelchair..... | 43 |
| Figure 24: Moving trough corridors..... | 44 |
| Figure 25: Sample image about corridor signs. | 45 |
| Figure 26: Sign next to door..... | 46 |
| Figure 27: Clear width of door..... | 46 |
| Figure 28: Internal accessible door widths (double leaf). | 47 |
| Figure 29: Internal accessible sliding door width. | 47 |
| Figure 30: Clear openings for different types of doors..... | 47 |
| Figure 31: Height of door handles. | 48 |
| Figure 32: Details of door handles. | 48 |
| Figure 33: Partially glazed doors. | 49 |
| Figure 34: Sample of accessible stair..... | 51 |
| Figure 35: Stair models. | 51 |
| Figure 36: Risers and treads (goings). | 52 |
| Figure 37: Stair nosing..... | 52 |
| Figure 38: Nosing with contrasting material..... | 53 |
| Figure 39: Handrails to stairs. | 53 |
| Figure 40: Sample ramp sections. | 54 |
| Figure 41: Ramp with intermediate landing..... | 55 |
| Figure 42: Ramp gradients..... | 55 |
| Figure 43: Short rise ramp design. | 56 |
| Figure 44: Ramp design with adjacent steps..... | 56 |
| Figure 45: Whole view of Nicosia Walled City..... | 67 |

| | |
|--|----|
| Figure 46: Locations of case buildings. | 68 |
| Figure 47: Information about Mevlevi Tekke Museum. | 73 |
| Figure 48: Parking space (North East), Mevlevi Tekke Museum. | 74 |
| Figure 49: Pavement, Mevlevi Tekke Museum. | 74 |
| Figure 50: Entrances, Mevlevi Tekke Museum. | 75 |
| Figure 51: Indoor corridors, Mevlevi Tekke Museum. | 76 |
| Figure 52: Passageways and doorways of indoor spaces, Mevlevi Tekke Museum. .. | 77 |
| Figure 53: Doors and passageways in the defined open spaces, Mevlevi Tekke Museum. | 78 |
| Figure 54: Pathways in the defined open spaces, Mevlevi Tekke Museum. | 79 |
| Figure 55: Steps and stairs in the defined open spaces, Mevlevi Tekke Museum. | 80 |
| Figure 56: Ramp in the defined open spaces, Mevlevi Tekke Museum. | 80 |
| Figure 57: Information about Arabahmet Culture House. | 83 |
| Figure 58: Parking space (North East), Arabahmet Culture House. | 84 |
| Figure 59: Pavement, Arabahmet Culture House. | 84 |
| Figure 60: Entrances, Arabahmet Culture House. | 85 |
| Figure 61: Corridors in semi open spaces, Arabahmet Culture House. | 86 |
| Figure 62: Doors in semi-open space, Arabahmet Culture House. | 86 |
| Figure 63: Passageways in semi-open space, Arabahmet Culture House. | 87 |
| Figure 64: Indoor corridors, Arabahmet Culture House. | 88 |
| Figure 65: Passageway, Arabahmet Culture House. | 88 |
| Figure 66: Doors in the defined open spaces, Arabahmet Culture House. | 89 |
| Figure 67: Pathway in the defined open space, Arabahmet Culture House. | 90 |
| Figure 68: Steps in the defined open spaces, Arabahmet Culture House. | 90 |
| Figure 69: Ramp in the defined open spaces, Arabahmet Culture House. | 91 |

| | |
|--|-----|
| Figure 70: Information about Dervish Pasha Mansion. | 93 |
| Figure 71: Entrances, Dervish Pasha Mansion. | 94 |
| Figure 72: Entrance hall, Dervish Pasha Mansion. | 95 |
| Figure 73: Corridors at the semi-open spaces, Dervish Pasha Mansion..... | 95 |
| Figure 74: Doors at the semi-open spaces, Dervish Pasha Mansion..... | 96 |
| Figure 75: Step in the semi-open space, Dervish Pasha Mansion..... | 96 |
| Figure 76: Corridors in the indoor spaces, Dervish Pasha Mansion..... | 97 |
| Figure 77: Doors at the indoor spaces, Dervish Pasha Mansion..... | 98 |
| Figure 78: Stair in the indoor space, Dervish Pasha Mansion. | 98 |
| Figure 79: Passageways in the courtyard, Dervish Pasha Mansion. | 99 |
| Figure 80: Stair in the defined open space, Dervish Pasha Mansion. | 99 |
| Figure 81: Information about Great Khan..... | 102 |
| Figure 82: Entrances, Great Khan. | 103 |
| Figure 83: Entrance hall, Great Khan. | 104 |
| Figure 84: Corridors at the semi-open spaces, Great Khan. | 105 |
| Figure 85: Doors at the semi open spaces, Great Khan. | 105 |
| Figure 86: Passageways in the courtyard, Great Khan. | 107 |
| Figure 87: Steps and stairs in the defined open spaces, Great Khan..... | 108 |
| Figure 88: Information about Bedesten..... | 110 |
| Figure 89: Back entrance of the site (South West), Bedesten..... | 111 |
| Figure 90: Pavements, Bedesten. | 111 |
| Figure 91: Entrances, Bedesten..... | 112 |
| Figure 92: Corridor in the semi open space, Bedesten..... | 113 |
| Figure 93: Door in the semi open space, Bedesten. | 113 |
| Figure 94: Ramp, Bedesten. | 114 |

| | |
|---|-----|
| Figure 95: Indoor corridors, Bedesten. | 115 |
| Figure 96: Passageways of indoor spaces, Bedesten. | 115 |
| Figure 97: Doors and passageways in the defined open spaces, Bedesten. | 116 |
| Figure 98: Pathway in the defined open spaces, Bedesten..... | 117 |
| Figure 99: Steps and stairs in the defined open spaces, Bedesten. | 117 |
| Figure 100: Ramp in the defined open space, Bedesten. | 118 |
| Figure 101: Information about the Eaved House. | 120 |
| Figure 102: Steps at the outdoor space of the building, The Eaved House. | 121 |
| Figure 103: Entrances, The Eaved House. | 121 |
| Figure 104: Entrance hall, The Eaved House..... | 122 |
| Figure 105: Corridors in the semi-open spaces, The Eaved House. | 122 |
| Figure 106: Doors at the semi-open spaces, The Eaved House. | 123 |
| Figure 107: Stair at the semi-open space, The Eaved House..... | 124 |
| Figure 108: Passageways in the courtyard, The Eaved House..... | 125 |
| Figure 109: Information about Lapidary Museum..... | 128 |
| Figure 110: Entrances, Lapidary Museum. | 129 |
| Figure 111: Corridor in the indoor spaces, Lapidary Museum. | 130 |
| Figure 112: Door in the indoor space, Lapidary Museum. | 130 |
| Figure 113: Doors in the courtyard, Lapidary Museum..... | 131 |
| Figure 114: Stair in the defined open space, Lapidary Museum. | 132 |
| Figure 115: Information about Lusignan House. | 134 |
| Figure 116: Entrances, Lusignan House. | 135 |
| Figure 117: Entrance hall, Lusignan House..... | 135 |
| Figure 118: Corridors in the semi-open spaces, Lusignan House..... | 136 |
| Figure 119: Doors at the semi-open spaces, Lusignan House. | 137 |

| | |
|--|-----|
| Figure 120: Stair at the semi-open space, Lusignan House. | 138 |
| Figure 121: Passageways in the courtyard, Lusignan House. | 139 |

Chapter 1

INTRODUCTION

Although there are some regulations and standards that are being used for the built environment, generally, these standards are suitable for people who are able to move by themselves. However, 2010 global population estimates that 15% of the people in the world live with some form of disability, which is equal to more than a billion people (WHO, 2011, p.261). The given rate is considerably high, and usability of built environment is significant for these people. Therefore, there is a problem about accessibility in the built environment around the world. As a result, it is necessary to design environments with accessibility standards.

1.1 Description of the Thesis

All people have equal rights for contribution of their social activities in the built environment. However, people with disabilities have limitations in gaining access to their environments. Disability is the result of inaccessible environments and these environments hinder the participation and inclusion of people (WHO, 2011, p.28). Although disabled people are part of the society, they have difficulties to attend social activities in their societies. Especially in public buildings, it is expected to have accessible standards for all people, and they had better contain usable spaces in themselves. The main problem for people with disabilities is inaccessible built environment. Although this issue is more sensitively taken into consideration in most of the developed countries, there is not enough sensitivity about the designs

of the built environments especially in developing countries and almost none in underdeveloped ones.

North Cyprus can be considered as intersection point of civilizations. Nicosia is the old capital of the North Cyprus, and the Walled City in Nicosia has a historic texture. Public historic buildings form the historical texture of the Walled City. Because of their importance for Nicosia as well as for the world heritage, public historic buildings in the Walled City are selected for observation. As Jester (1993) states, "Historic properties are irreplaceable and require special care to ensure their preservation for future generations". Historic properties in Nicosia Walled City are expected to preserve in terms of accessibility standards to provide accessibility for public. As also accepted by the "Americans with Disabilities Act" access to historic properties open to public is accepted as a non-civil right in the world (Jester, 1993).

Vertical and horizontal circulations of selected public historical buildings are investigated in terms of accessibility standards with the developed evaluation method. The method is developed under the light of international accessibility standards such as Universal Design, Barrier-Free Design, and American Disability Act (ADA).

It is important to remember that disabled or impaired people cannot change their disability or make them disappear; however, barriers can disappear by building fully accessible buildings which can ease their life at least.

1.2 Accessibility Conditions in North Cyprus

There is a book published by Turkish Cypriot Human Rights Foundation on this subject titled "Rights of Persons with Disabilities in North Cyprus". The book includes rights of people with disabilities and regulations in North Cyprus.

The definite number of the people with disabilities in North Cyprus is not known. There are seven civil society organizations in TRNC dealing with disabled persons rights. The Engelsiz Initiative (Turkish Cypriot Disability Rights Initiative) is one of these organizations and it has "collected 4,000 signatures for the approval of the Convention on the Rights of Persons with Disabilities and has played a crucial role in the process of ratification on 27 July 2010" (Polili, 2012). The Engelsiz Initiative have made many activities to improve the awareness of the society about rights of people with disabilities.

"The Covenant on the Rights of Persons with Disabilities is incorporated into the domestic law. However the necessary provisions were not incorporated to domestic law to increase community awareness" (Polili, 2012). In other words, although the contract is approved, it is not adapted to domestic law; even the definition of disability is not revised in the law. In this situation it is very hard to heighten the consciousness of society.

"In many cases, civil society instead of the state has to fulfil the duties of state. However, human rights treaties impose three levels of obligations on state parties: the obligations to respect, protect and fulfil human rights" However, these three obligations and rights of people with disabilities are not considered, and this matter is not on the political agenda of the government of North Cyprus (Polili, 2012).

1.3 Problem Statement

The main problem about accessibility comes from the environment and it is the result of the development of built environment without awareness. As a result, people have many difficulties when they experience their environment. It is the environment which creates barriers, especially for disabled people who have permanent or

temporary physical limitations on their body. For instance, they might not be able to access to a bank, a school, a hospital, or a museum by themselves because of the steps. In order to provide accessibility in buildings, accessibility standards are expected to be adapted to access spaces of buildings through the elements, such as, stairs, ramps, entrances, doors, and corridors. What is more, historical buildings which have been re-functioned for a public function are expected to be adapted for universal design criteria. There are standards, to be accepted as regulations for buildings, so as to improve accessibility conditions in built environment.

1.4 Purpose of the Study

The main aim of the study is to study the accessibility standards for public buildings and designate accessibility standards of horizontal and vertical circulation paths in the public buildings. As the case study, culturally re-functioned public historic buildings, on the "Walking Route"(Blue Line¹), in the Northern part of Nicosia Walled City, have been evaluated in terms of international accessibility standards. Although the development of the new city life continues, the planning of Northern part of the Nicosia Walled City does not give sufficient access to all people anymore. Because of its historical built environment, the city has touristic value and it had better to be disabled friendly. As a result, the research is important to make an enhancement about accessibility problem of the historic buildings in the Northern part of the Nicosia Walled City. The research targets to draw attention on accessibility conditions of the re-functioned public historic buildings on the "walking route" in the Walled City, and the gap about accessibility studies on this valuable site.

¹ Blue Line is a touristic route by Nicosia Municipality/ UNDP/ Ministry of Tourism in Guide Books or Touristic Panels.

1.5 Methodology

Literature survey and observations on site are used as research methods in this qualitative study. Literature survey is used to reach previous studies like books, journals, articles, reports and papers etc. which include applied samples, definitions, and standards about accessibility.

Selected buildings have been observed and analysed in terms of accessibility by using accessibility standards. Observation of these buildings has been done by using a chart which has been developed by the author. Circulation of indoor spaces, semi open spaces, defined open spaces within the site and circulation of outdoor spaces of buildings which are in close relationship with the indoors have been analysed by using this chart. While analysing these buildings, circulation spaces are categorized as horizontal and vertical circulation spaces. Accessibility conditions of circulation spaces and components, like entrances, corridors, doors, stairs etc. have been observed by taking photographs and measuring.

1.6 Limitations of the Study

The study is determinate with the Northern part of Nicosia Walled City, in North Cyprus. This study is limited to the public historic buildings on the "Walking Route" (Blue Line). There are many public buildings that have historical value on this "Walking Route". Case buildings have been selected according to their functions. There are various functions of buildings like; cultural, administrative, commercial, and religious on the "Walking Route". Culturally re-functioned public historic buildings have been selected as cases, because these buildings are open to both national and international visitors, so they have more users than the other public buildings.

Many terminological definitions and studies have been developed about accessibility. One of them is 'barrier-free design'. Meuser (2009) stated that, barrier-free buildings are the world that we create ourselves- from pavement to house to light switch-, so designs of buildings are expected to be coherent with the abilities and needs of all people, without any support and adaptation (Fischer, 2009). From that point of view, interiors and close surroundings of these buildings have been analysed in terms of accessibility. When buildings are examined according to accessibility conditions, the user profile is considered as people with mobility impairments and to provide accessibility for all people is the main target. If a person with a wheelchair can access to a building, it is accepted that other people like elderly, children, or parents with a stroller can also access to the building.

1.7 Definitions about disability

All people who live in the same society are accepted as users of public buildings. Adult males used to be taken as a standard when the buildings were designed. However, people have differences about their physical abilities. In other words, designers have responsibilities for making universal, pragmatic and aesthetic designs which are accessible (Wilkoff, 1994).

Wilkoff (1994) stated that, designers are expected to know the meaning of disability to understand the needs of disabled people. Most known and accepted definition is the international classification of impairments, disabilities and handicaps (ICIDH) which belongs to the World Health Organization (WHO) . ICIDH defines impairment, disability and handicap as follows:

"Impairment: Any temporary or permanent loss or abnormality of a body structure or function, whether physiological or psychological. An impairment is a disturbance affecting functions that are essentially mental

(memory, consciousness) or sensory, internal organs (heart, kidney), the head, the trunk or the limbs.

Disability: A restriction or inability to perform an activity in the manner or within the range considered normal for a human being, mostly resulting from impairment.

Handicap: This is the result of an impairment or disability that limits or prevents the fulfilment of one or several roles regarded as normal, depending on age, sex and social and cultural factors" (Barbotte et al., 2001, p.1047).

The study focuses on people with physical disabilities, for improvement of the accessibility level of the buildings according to disabled people's needs. The society cannot be divided as healthy people and others. The built environment should be used equally by all people. Essex (ND) explains about preservation of historic buildings by using applied case studies. The main aim of this study is to make public historic buildings accessible for all people including disabled people by overcoming barriers. Thus, this study aims to be beneficial for others, such as the elderly, and young children and their parents. In a society all people have equal rights, and the rights of people can be protected by governmental rules.

1.8 Re-Functioned Historic Buildings & Accessibility

As accessibility is an important issue on the built environment, historic buildings are one part of the built environment also. For this reason, historic buildings are expected to have accessible conditions as well as contemporary buildings. However, historic buildings have been built without accessibility awareness, so they generally have inaccessible conditions. A research by Jester and Park (1993) realized that, most of the historic buildings are not designed according to accessibility standards. As a result, they are not accessible for all people, especially disabled people. To provide barrier free environments for all people, it is needed to adapt their fixtures by some renovations.

Renovation is a significant subject for sustaining public historic buildings. Therefore, regulations about re-functioning of public historic buildings are considered as a part of accessibility. Accessible improvements of these buildings are possible with modifications of some features. Douglas (2006) mentioned about these modifications;

- "Widen doors (900mm), remodel entrances and access routes (to avoid steps) by providing level access or ramp at entrances.
- Alter toilet facilities, including enlarging the cubicles and installing easy to use tabs. Cubicle's doors should be folding and easy to use.
- Provide lifts or stair-lifts, even in low-rise buildings.
- Adjust height and colours of handrails and other guarding.
- Fit mechanically opening doors on fire escapes.
- Provide dedicated parking spaces and dropping off points for people with mobility impairments".

These accessibility modifications have the same base with accessibility standards which are required to apply to buildings. As a result, difference is related with sensitivity about renovation of public historic buildings when they are re-functioned or re-used.

A community consist of various people who have different abilities, and all of them have equal rights (Adams and Foster, 2004). The study titled 'Easy access to historic buildings' carries this sensitivity and focuses on respects to disability rights. In addition, Adams and Foster (2004, p.9) stated about The Disability Discrimination Act (DDA) in 1995, as "it is important to remember that the DDA is about people and not buildings. The Act does not include standards for accessible building design, though the relevant Codes of Practice do refer to Part M of the Building Regulations as a reasonable standard".

Although many historic buildings have been adapted to today with restorations and renovations or re-functioning, their accessibility conditions are not adapted to

international standards. Besides, with the development of the awareness about this issue, it is expected from designers to be more sensitive about accessible adaptations of valuable buildings. Meuser (2009) cited in Fischer (2009), mentioned about successful conversion of buildings which are transformed into more barrier-free spaces with intelligent organizations. Bode museum is one of these examples and the figures which are below show the accessible modifications of the museum.



Figure 1: Retractable access lift, Bode Museum, Berlin (Fischer and Meuser, 2009, p: 114-115).



Figure 2: Through floor lifts, Bode Museum, Berlin (Fischer and Meuser, 2009, p: 118-119).

Hella Rolfes (Architect) mentioned about the renovation of Bode Museum;

"As in nearly all 19th - and early 20th -century museums, the Bode Museum did not make any provision for barrier-free access. The stairs outside, the main entrance and in the domes made it almost impossible for people with restricted mobility to enter the museum, so one of the key aims of the renovation was to open the museum up to all visitors and provide steeples access and the maximum possible freedom of movement inside"(Fischer and Meuser, 2009, p.109).

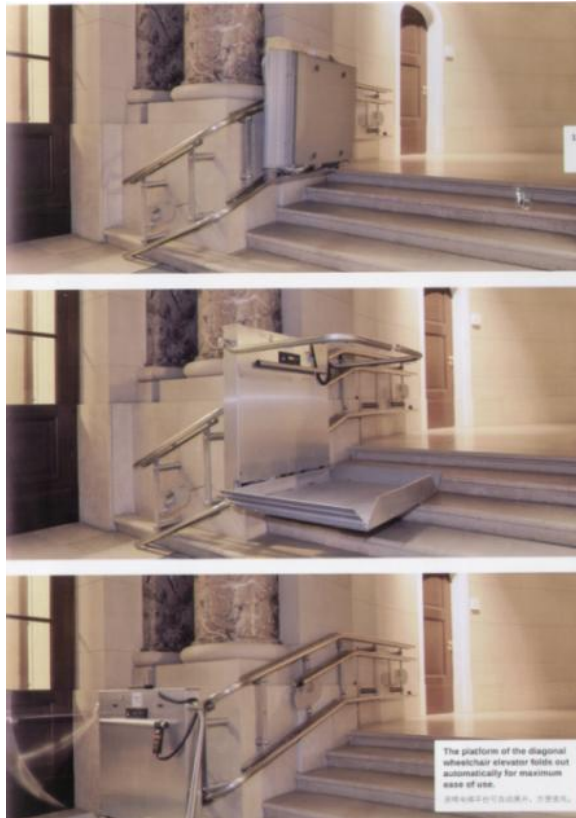

Figure 3: Stair Wheelchair Platform Lift, Bode Museum, Berlin (Fischer and Meuser, 2009, p.117).

Some international studies about preservation and conservation of historic buildings also give response to accessibility applications. 'Improving access to listed buildings in the City of London' by Department of Planning & Transportation and Department of Community Service has analysed buildings according to the requirements given below:

- a) Understanding what kind of activities eventuates in the building.
- b) Who the user profile and staff of the building are?

c) If there is accessible entrance that is coherent with the building, or if there is any alternative route?

d) If there are any renovations about plan organization to enhance accessibility on the building?

e) If suggestions about renovation, fit with characteristic of the building?

(Department of Planning Transportation and Department of Community Service, 2011).

There are different examples of accessible historic buildings which are renovated. These examples present the possibility of improvement of accessibility in the historic buildings. The first example is Philharmonie building in The Netherlands. Accessibility between floors is provided with adapting a passenger lift.



Figure 4: Adapted passenger lift, Philharmonie, The Netherlands (Uffelen, 2011).

Queen's House, in Greenwich, has an additional entrance which furnishes an alternative route to building, without using stairs.



Figure 5: Alternative entrance at basement, Queen's House, Greenwich (Adams and Foster, 2004, p.27).

Chapter 2

SIGNIFICANCE OF ACCESSIBILITY

This chapter generally focuses on accessibility to building, also studies and acts about accessibility. To understand accessibility, previous studies are taken into consideration as chronologically. Moreover, some acts, organizations and approaches are described to clarify the present condition of the accessibility to building in the world. Additionally, standards and concepts are handled about the accessibility, which are used in this study.

As it was regarded in the introduction, the rate about disability is about 15% of the world population (WHO, 2011). However, regulations are not enough to provide accessibility in developing countries. For disabled people who have some limitations, that cause problems like not being able to access a high-levelled building. Also, unconscious society creates several barriers for people with disabilities. Adams and Foster (2004, p.4) mentioned that,

"This perspective about disabled people has changed considerably and it is recognized that disabled people have equal rights with the rest of the society instead of remaining as passive recipients of donations. However, traditional prejudices still continue, and there are some barriers that obstruct full participation of disabled people to their daily activities".

As a result, it is significant to understand what kind of facilities can be provided to eliminate the barriers.

- Lack of accessibility in built environments is one of the problems for people with disabilities. Hence, it is significant to understand what accessibility means.

- It is beneficial to find out what kinds of studies have been done about accessibility in the world.
- Also, it is useful to survey about the circumstance of accessibility in North Cyprus.

2.1 Understanding Accessibility

Accessibility in general is defined by Oxford Dictionaries as, " (of a place) able to be reached, entered or used by people who have a disability: *features such as non-slip floors and accessible entrances*" (URL 2.1).

In this study, accessibility means removing barriers that cause problems for people with disabilities, and providing access to places. In 21st century it is significant to follow innovations in all industrial fields and answer the needs of people practically. Easy access to buildings or other things like internet, web sites and technologic devices without restrictions is very important. Accessibility facilities are needed to solve problems about barriers that handicapped people face.

Especially, for disabled or impaired people, it is difficult to get the same service from their environment as the other people because of the built environment inaccessible conditions. Also, elderly people, mothers with baby strollers, children, short or overweight individuals may have difficulties because of the barriers of interior design systems. Each person does not have a standard body measurement. There are various kinds of body types. Some people have difficulties about movement and cannot pass through stairs at all. Some of them have babies with them, however, some corridors may be narrow to circulate. Short people like a child cannot reach a service bank, and for overweight people it is difficult to sit on an ordinary chair.



Figure 6: A kind of mobility experience of person with stroller (Fischer and Meuser, 2009, p.).

Accessibility is one of the problems which is related with the designer. About this concept, the responsibility to solve the problem of the built environment, regards to its designer. They can create accessible and more usable environments for everyone. Instead of making handicapped people's life more difficult, it is possible to ease their life by creating better accessible buildings.



Figure 7: A kind of obstacle in front of the disabled people (URL 2.2).

Governments, organizations, and related individuals have made various studies about the matter of accessibility. It is important to organize built environment according to whole population which have different abilities and physical features. Developing countries have started to discover deficiencies of the existing environment. They have been trying to renovate, restore, and regulate their built environment through accessibility rights.

At the beginning of 1950's awareness about importance of accessibility started. Some studies have been done on the same subject. These are, 'accessible design', 'barrier-free design', 'universal design', 'inclusive design' and 'design for all'. The most pronounced common point among them is 'accessibility for disabled individuals'. In addition to these terms, there are some organizations and governments' acts which are considered for disabled people like, American Disability Act (ADA), World Health Organization (WHO), The European Disability Forum (EDF), and Uniform Federal Accessibility Standards (UFAS) Retrofit Guide. ADA's standards and WHO's regulations are the most popular and more common, and have been applied widely.

As it is mentioned before, in order to understand accessibility, the chronological evolution of the accessibility was analysed. It started in 1950's with the barrier-free movement which is about the physical barriers in the environment. So, various terms like barrier-free design and barrier-free environments, which are being used nowadays, come from this movement.

Table 1: Evolution of accessibility.

| Chronicle | Movements and Acts |
|---|---|
| 1950 | The barrier-free movement in the 1950s <ul style="list-style-type: none"> • Beginning of the changing process in public policies and design practices. • Regulations about education and employment for disabled. • Reorganization of the physical barriers in the environment. |
| 1960 | The Civil Rights Movement of the 1960s <ul style="list-style-type: none"> • Smoothing the path for the Disability Rights Movement and others that in 1970s, 1980s, and 1990s. |
| 1961 | In 1961, the American Standards <ul style="list-style-type: none"> • Publishing the first accessibility standard titled, “A117.1–making buildings accessible to and usable by the physically handicapped.” |
| 1968 | The Architectural Barriers Act of 1968 <ul style="list-style-type: none"> • Removing the physical obstacles which are the most significant barrier for employment of the disabled people. |
| 1973 | Section 504 of the Rehabilitation Act of 1973 <ul style="list-style-type: none"> • Against on the basis of disability and applied federal agencies. • Announcing of the regulations about health, education and welfare in 1977. |
| 1975 | The Education for Handicapped Children Act of 1975 <ul style="list-style-type: none"> • Make certain, free convenient education for all disabled children. • Influencing related educational programs and facilities. |
| 1988 | The Fair Housing Amendments Act of 1988 <ul style="list-style-type: none"> • Requiring accessible units (four or more) in all new multifamily housing. • In 1991, Accessibility Guidelines were issued by the U.S. Department of Housing and Urban Development. |
| 1990 | The Americans with Disabilities Act of 1990-2010 (ADA) <ul style="list-style-type: none"> • Reinvigorating the prevalence of public awareness on the civil rights of people with disabilities. • By this law, it became a must to remove existing physical barriers that prevent access. • With modifications by the U.S. Department of Justice, these guidelines became the practicable ADA Standards for Accessible Design. |
| 1996 | The Telecommunications Act of 1996 <ul style="list-style-type: none"> • Providing that telecommunication devices and services to be “designed, developed, and fabricated to be accessible to and usable by individuals with disabilities, if readily achievable.” |
| 2005 | Accessibility For Ontarians with Disabilities Act, 2005 <ul style="list-style-type: none"> • Establish, implement, maintain and document a multi-year accessibility plan, which outlines the organization’s strategy to prevent and remove barriers and meet its requirements under this Regulation. |
| 2012 | European Accessibility Act, 2012 <ul style="list-style-type: none"> • Legislative initiative to improve accessibility of goods and services in the Internal Market. |
| Information is adapted from, Story (1998), URL 2.3 and URL 2.4. | |

2.2 Approaches about Accessibility

Although the age we are in, provides us a lot of technological advances, due to the lack of medicine or genetically advances, there are lots of disabled, impaired or handicapped people.

For example, two world wars created many disabled veterans and they have physical difficulties. Moreover, disabled population do not consist of just veterans; there are various kinds of disabilities (Story, 1998).

With accessible built environment, all individuals can have a chance to join social activities and get services. Thanks to the various studies have been done about accessibility, from past to present. Designers are expected to consider the diversity of the population. Buildings and facilities should give access for diverse people.

There are several approaches which are enhanced with the awareness of disability, and the common aim is to improve accessibility of the living space. Although the common matter is illustrated as '**Inclusive Design**' today, it is also known as '**Universal Design**', '**Barrier-Free Design**', '**Design for all**', '**User-Centred Design**', and '**Sensitive Design**' as well.

In other words, it is necessary to design according to all types of people and their abilities. When researchers and designers start to think with this sensitivity, they try to find out more accessibility solutions. It started at the beginning of the 1950's with Barrier-Free term. The main aim of Barrier-Free Design was to remove the physical barrier from environment and to give their public rights like education and employment for disabled. Then, Universal Design approach was defined as a term in

1985, on the Barrier-Free Design basis. They have many differences but the common point of both was human. The main objective of Universal Design is to provide usable built environment by all people without any alterations or adaptations. When this approach became a necessity in the world, conscious designers started to think according to its seven principles (Table 2.2). From the beginning of the approach of the Universal Design to recent days, it is used for creating accessible environments or products. On the fundamentals of Universal Design, the latest approach which is Inclusive Design has been developed.

In order to understand accessibility, different acts and studies, which have similar content on the same base, are considered as a whole. These studies have been selected according to their acceptance and being widespread in the world. Also, these studies are followed by other studies, and they compose the fundamentals for future studies as well.

2.2.1 Barrier- Free Design

Awareness about need of accessibility started with “barrier-free movement”. "The initial term used around the world was barrier-free design and related to the efforts that began in the late 1950s to remove barriers for disabled people from the built environment" (Preisser and Ostroff, 2001, p.1.5).

At the beginning, barrier-free design focused on disabled bodies. However, barrier-free homes and environments are beneficial for all people. For instance, when a disabled person lives in a barrier-free family home, other family members can benefit from the functions easily. 'Building and design for all' or 'people friendly building' are other names for barrier free design living areas.

"Numerous reports and experts opinions from Germany and European neighbouring countries have concluded that an environment accessible without barriers is absolutely essential for around 10 per cent of the population, necessary to some extent for up to 40 per cent and simply comfortable for 100 per cent" (Fischer and Meuser, 2009,p:11).

Fischer and Meuser (2009) gave public toilets as an example for functional, accessible, and usable area without any barriers like thresholds and stairs.



Figure 8: An accessible toilet example (Fischer and Meuser, 2009, p.23).







2.2.2 Universal Design (UD)

Universal design was first used by Ron Mace (1985) as a term in the United States. He defined universal design as "... an approach to design that incorporates products as well as building features which, to the greatest extent possible, can be used by everyone" (Snider & Takeda, 2008). One of the targets of universal design is to provide access to everyone universally. "The design of products and environments to be usable by all people, to the greatest extent possible, without need for adaptation or specialized design" is the enhanced definition of universal design used by The Centre for Universal Design on April 1, 1997 (Preisser and Ostroff, 2001).

Thus, usability of built environment by all people is the main objective of Universal Design. "Universal design may or may not include standards, but the design must be universally acceptable and usable by the population that will use the specific piece of the built environment" (Snider & Takeda, 2008).

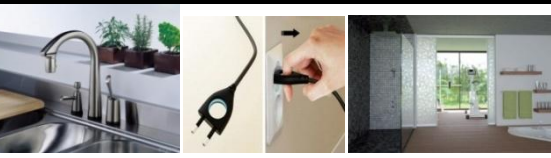
Also, it is important to adapt universal design to an environment according to the culture of the people who will be using that built environment. In other words, Universal Design may differ from country to country in usability, accessibility or functionality. Although it does not have regular rules, there are some general principles that designer should follow when they design universally (Snider and Takeda, 2008). Principles of Universal Design are specified and illustrated in Table 3.

Table 2: Principles of Universal Design.

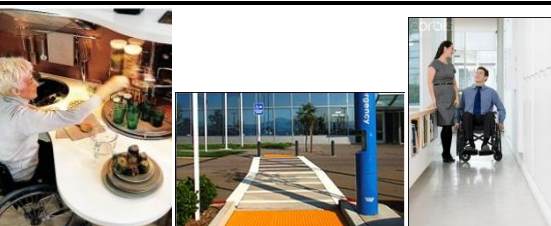
| Principles of Universal Design | Design examples |
|---|--|
| <p>1. Equitable Use</p> <p>The design is useful and marketable to people with diverse abilities.</p> |  <p>URL 2.5 URL 2.6 URL 2.7</p> <p>Equitable use.</p> |
| <p>2. Flexibility in Use</p> <p>The design accommodates a wide range of individual preferences and abilities.</p> |  <p>URL 2.8 URL 2.9 URL 2.10</p> <p>Flexibility in use.</p> |
| <p>3. Simple and Intuitive Use</p> <p>Use of the design is easy to understand, regardless of the user's experience, knowledge, language skills, or current concentration level.</p> |  <p>URL 2.11 URL 2.12 URL 2.13</p> <p>Simple and intuitive use.</p> |
| <p>4. Perceptible Information</p> <p>The design communicates necessary information effectively to the user, regardless of ambient conditions or the user's sensory abilities.</p> |  <p>URL 2.14 URL 2.15 URL 2.16</p> <p>Perceptible information.</p> |
| <p>5. Tolerance for Error</p> <p>The design minimizes hazards and the adverse consequences of accidental or unintended actions.</p> |  <p>URL 2.17 URL 2.18 URL 2.19</p> <p>Tolerance for error.</p> |
| <p>6. Low Physical Effort</p> <p>The design can be used efficiently and comfortably and with a minimum fatigue.</p> |  <p>URL 2.20 URL 2.21 URL 2.22</p> <p>Low physical effort.</p> |
| <p>7. Size and Space for Approach and Use</p> <p>Appropriate size and space is provided for approach, reach, manipulation, and use, regardless of user's body size, posture, or mobility.</p> |  <p>URL 2.23 URL 2.24 URL 2.25</p> <p>Size and space for approach and use.</p> |
| <p>Principles are quoted from Centre for Universal Design,1997(Story, 1998, p:34 -35).</p> | |

2.2.3 Inclusive Design

Inclusive design which indicates that everyone should have an equal chance to get a full service from all facilities supplied is another term to highlight the necessity of usable environment. Its main objective reveals about the importance of comfort to people without any discrimination. Moreover, any attempt to imply any special treatment would replace the confidence dignity and independence of the user (Alderson, 2010). There are four points emphasized by Alderson (2010), first of which is the place of people in design, regarded as heart pumping blood to circulate or move around easily in an environment. Secondly, people should be able to get an advantage of an environment without any differentiation. Therefore, their lack of ability would not be a problem to affect them negatively. Finally, the major target is to provide flexibility.

Under the light of social definition of disability, the target of inclusive design is to design products and environments according to diversity of people. As a result inclusive design can be usable by all without the requirement of any changes(Hanson, 2012, p.12).

"An inclusive environment is one in which all users, whatever their abilities, are able to carry out their day to day activities comfortably, effectively and safely without being restricted by the poor design, maintenance or management of the built environment", (Hanson, 2012, p.13).

Table 3 reveals the difference between 'Special Needs' and 'Inclusive Design' concepts.

Table 3: From ‘Special Needs’ to ‘Inclusive Design’ (Hanson, 2001; Hanson, 2012, p.13).

| Special Needs | Inclusive Design |
|---|---|
| Designer client. Persona of a young, fit, active, male, white adult as the yardstick for good design. | People are individuals, who have different needs and requirements during their life course. |
| Others - older people and people with disabilities - are not ‘normal’ clients. | Us - we all have goals / aspirations as well as problems / impairments. |
| They have ‘special needs’. | We share ‘generic needs’. |
| Micro-environmental approach. | Macro-environmental approach. |
| Ethos of specialisation and pragmatism. | Ethos of normalisation and enablement. |
| Tailors the environment so that it is ‘just right’ for each client group. | Extends parameters of design until no one is excluded. |
| Telling people what they need. | Asking people what they want. |
| Does your disability prevent you from using the city centre? | What is it about the design of the city centre that prevents you from using it? |

Below, the principles of Inclusive Design are shown in the Table 4.

Table 4: Principles of Inclusive Design (Centre for Universal Design, 1995; Hanson, 2012, p.14).

| Principle | Description |
|------------------|---|
| Equitable | The product is useful and marketable to people with a range of abilities. |
| Flexible | It can accommodate a wide range of individual needs and preferences. |
| Intuitive | The product is easy to use. |
| Effective | It works in most situations and for most people. |
| Tolerant | The product can cope with user-errors. |
| Efficient | It does not stress or tire the user. |
| Appropriate | It is ergonomically designed to be acceptable to the majority of users. |

The belief to serve widest range of people without causing any barriers, and to be able to provide moving around easily, without limiting mobility, are among the principles of inclusive design. To make a better product and to meet the target of reaching equality of opportunities will be the result of inclusive design by creating a better architectural usability of buildings. Despite its pluses 'one size fits all solution' has been criticized since the possibility of exclusion of some (Hanson, 2012).

2.3 Acts and Organizations about Accessibility

From the beginning of the awareness to present days, governments and social community foundations have been studying on the accessibility. Developed countries have more guidelines and regulations which are being followed by many developing countries. American Disability Act (ADA), World Health Organization (WHO), Uniform Federal Accessibility Standards (UFAS) Retrofit Guide, and The European Disability Forum (EDF) are just four and the most known among them. These beneficial studies and their regulations' topics are related with health, social environment, cultural environment, as well as built environment of people. The main common point of these studies is human. The selected studies have been considered because of being known world widely and accepted considerable samples in the case of other accessibility studies.

2.3.1 American Disability Act (ADA)

ADA endorsed lots of regulations to ease the life of disabled and to lead designers to construct a functional building. These regulations of Americans with Disabilities have been revised so many times accordingly to the recognised and noticed special needs. "These regulations adopted revised, enforceable accessibility standards called the 2010 ADA Standards for Accessible Design "2010 Standards" or "Standards"". In spite of the standards, ADA has set some rules to produce more technical and practical products (Department of Justice, 2010).

"The 2010 Standards set minimum requirements - both scoping and technical - for newly designed and constructed or altered state and local government facilities, public accommodations, and commercial facilities to be readily accessible to and usable by individuals with disabilities" (Department of Justice, 2010, p.5).

Design standards are arranged in units as follows;

- Parking spaces
- Ramps
- Doors
- Stairs
- Elevators
- Toilets
- Wheelchair spaces
- Passing spaces
- Slopes, floor surfaces
- Signs
- Handrails
- Telephones
- Moving & turning spaces

All of these elements have specific standards in themselves. For example, there are separate standards about ramps for interiors and exteriors. Their slopes, handrail heights, and floor surfaces may show differences. The main scope of ADA is to create accessible built environments by applying regulations. ADA Standards concentrate especially on disabled people, but they are beneficial for all people. The major aim is to create accessible environments. When staircases design is usable by a person who has limited physical ability, it is also suitable for an able person, and provides easy access for all.

2.3.2 World Report on Disability

The world reports provide global assessment of disability continually and keep it up to date. It always bases on evidences to prove the estimates that there are more than one billion people who have a form of disability. The report also highlights that despite some countries' adequate accessibility to places; there are lots of barriers which include stigma, discrimination and lack of health care and rehabilitation

services. Therefore, the question comes up if they are penalized or tried to be rehabilitated because of their disability (WHO, 2011).

Moreover, the report also puts forward that lots of disabled people do not receive equal opportunities to access governmental, private or social services and feel discriminated. However, it is pointed out that many disabled people are aware of human rights. "Following the entry into force of the United Nations Convention on the Rights of Persons with Disabilities(CRPD), disability is increasingly understood as a human rights issue". This awareness has increased their expectation to have equal rights instead of feeling like living in poverty, they would rather have equal socioeconomic outcomes(WHO, 2011, p: 21-22).

The World Health Assembly could not accept this and asked World Health Organization (WHO) to prepare a report to prevent, manage, and rehabilitate disabled people's problems. The World Bank as a partner supported that report since previous outcomes have revealed that awareness of accessibility might be increased by collaboration. Cooperation between agencies would definitely serve better to create accessible built environments to disabled people. Consequently, to have better services WHO makes a lots of studies (WHO, 2011).

"The Report by WHO- World Health Organization, focuses on measures to improve accessibility and equality of opportunity; promoting participation and inclusion; and increasing respect for the autonomy and dignity of persons with disabilities" (WHO, 2011, p.22).

The report set aims to improve the accessibility to built environment for disabled people. "The overall aims of the Report are:

- To provide governments and civil society with a comprehensive description of the importance of disability and an analysis of the responses provided, based on the best available scientific information;
- Based on this analysis, to make recommendations for action at national and international levels" (WHO, 2011, p.21).

"It is anticipated that the recommendations in this Report will remain valid until 2021. At that time, the Department of Violence and Injury Prevention and Disability at WHO headquarters in Geneva will initiate a review of the document" (WHO, 2011, p.22).

2.3.3 Uniform Federal Accessibility Standards (UFAS) Retrofit Guide

UFAS Retrofit Guide or Manual has been prepared to supply a manual for designers to improve the accessibility. In this guide it was focused on variety of disabled people due to the lack of people's awareness. "Also, for providing information to promote the accommodation needs of people with diverse disabilities, it demonstrates on human factors data ".When it is regarded to accessibility lots of people think about people with wheelchairs, however, in this guide not only wheelchair users but also ambulatory mobility impairments, visual impairments, hearing impairments, and other impairments have been taken into consideration. The main target of this guide is to provide 'abilities' through design in accommodations and facilities. "UFAS requirements have been improved to represent minimum acceptable expanse and movement space dimensions, level changes, slopes, operating pressures, shear and tensile force requirements, clearances, surface conditions, etc." (Barrier Free Environments,1991).

Also it was emphasized that accessible designs not to exclude disabled should be applied compulsory. The needs of humans should be met without making any discrimination of able body or disabled."Also, UFAS accept human factors and performance specifications as obligatory for accessible design. It is necessary to understand and accept knowledge about human factors to design for people" (Barrier Free Environments, 1991).

2.3.4 The European Disability Forum (EDF)

The European Disability Forum is a nongovernmental organization, which acts on behalf of 80 million disabled Europeans. It should be emphasised that this form managed by disabled people and their families. Lots of organizations and commissions have realise and legislative proposal which should be approved by this organization. "The European Disability Forum (EDF) provides an overview of the implications of the rights recognised by the European Union Treaties linked to Free movement of persons, goods and services, for persons with disabilities" (Nyman, 2011, p.11).

The EDF focuses on the independence of disabled people to reach the services equally like other healthy people.

"The Freedom Guide concretely aims to illustrate the fact that freedom of movement is still not a reality for persons with disabilities. On the other hand, it also highlights that the internal market is still a place of exclusion due to the continued circulation of inaccessible goods and services. This must change, to ensure that all citizens can enjoy their human and civil rights"(Nyman, 2011, p.11).

As one of the member of the EDF, The UN Convention of the Rights of Persons with Disabilities (UNCRPD) intend to "promote, protect and ensure the full and equal

enjoyment of all human rights and fundamental freedoms by all persons with disabilities, and to promote respect for their inherent dignity" (UN, 2006; URL 2.25).

2.4 Definitions and limitation

Accessibility problems are related to urban design, architectural design, interior design, industrial design and even graphical design. The focus of this study concentrates on the interior design of public buildings and their close surrounding.

It should be kept into mind that there are lots of approaches and acts about disabilities. All of the approaches and acts provide guidelines for designers. In addition to all of them, there is another concept which is "sensitive design". Sensitive design is related with designers' sensitivity about design. "Designers can look at user needs from various points of view, and understanding user needs is regarded as key to strategic thinking in user centered design" (Lai et al. 2010, Park, 2012, p: 80). Sensitive Design encourages designers to focus not only on physical characteristics but also all kinds. Therefore, Sensitive Design emphasizes inclusive design rather than user-centered design.

"The use of the term “inclusive” rather than “universal” reflects the view that “inclusivity” is a more achievable, and in many situations, appropriate goal than “Universal Design” or “Design for All”. Additionally, “sensitive” replaces “centred” to indicate that it is rarely possible to design a product that is truly accessible by all potential users" (Newell, 2011,p:237).

2.5 Evaluation of the Chapter

The common point of all acts and approaches about accessibility is human being. Necessities of people create main elements of components about design. As a result, diversity of people affects design solutions, so, designers are expected to be sensitive about their designs. There is a strong interaction between human and built

environment. Designers are responsible for respecting all kinds of people when they are designing. It is expected from designers to design according to accessibility standards.

"Designers can look at user needs from various points of view, and understanding user needs is regarded as key to strategic thinking in user centered design" (Lai et al.,2010; Park, 2012, p.80).

All of the mentioned approaches and acts have similar purposes about rights of people with disabilities to ensure accessible environments. In addition to these studies, it has been mentioned about 'Barrier Free Designs' or 'Sensitive Inclusive Design'. As it is clear, the main focus of all approaches, acts or designers that are aware of inaccessibility are expected to develop an empathy with the people who cannot get services equally like other people to provide a social situation by easing their life with accessible environments. Therefore, to provide accessible circulation in interior spaces, it is expected from interior designers to design interiors, in this respect.

The importance of accessibility and past studies have been analyzed within this chapter. Furthermore, it is expected to be aware of accessibility standards to design accessible spaces. Hence, the accessibility standards have been mentioned in the following chapter.

Chapter 3

ACCESSIBILITY STANDARDS FOR THE CIRCULATION PATHS IN PUBLIC BUILDINGS

As one of the values of design, circulation has an initial role that gives design quality to a space. Circulation quality supports the comfort of the people who use the space and provide an accessible space for everyone. Black (2005) mentions interior circulation as:

"They are all walking areas on all floors of a building required for physical access to some subdivision of space, whether physically bounded by partitions or not. Including horizontal and vertical circulation, which should be but is not limited to, public corridors, exhibition spaces, entrance foyers, elevator lobbies, tunnels, bridges, and each floor's footprint of elevator shafts, escalators and stairways? Also included are corridors, whether walled or not, provided they are within the outside face lines of the buildings to the extent of the roof drop line" (Black, 2005; Elottol, 2011, p.226).

Circulation is one of the significant issues in public buildings. Standards frame minimum requirements about circulation for all kinds of buildings. Also, consideration of a public building by designers about accessibility of circulation is considerable. Public buildings have an initial role to obey the rules because it is open to public use. The term 'public' does not only contain all people in a community, but also all people from the world. So, it is expected to give service to every single person of the public, including wheel chaired people. Many people go and visit public places with various needs and reasons. Public buildings are expected to give

service with their well designed functions and accurate fixtures. Within this perspective, circulation paths are selected as the focus of this study.

Like in many studies which are mentioned before, in this study as well, circulation is categorized as interior circulation and exterior circulation. Although both of these circulation areas belong to different fields, they have common points because these spaces are linked to each other with a strong relation. Circulation of exterior is analyzed by landscape architects and urban planners.

- i. Close surrounding circulation,
- ii. Relation of interior-exterior circulations, and
- iii. Interior circulation, are dealt by architects and interior architects/designers.

So, concentration of this study is

- i. Circulation of interior paths and
- ii. Interior-exterior relation of paths.

Interior-exterior relation of paths is analyzed as circulation paths of outdoor spaces. Circulation within the building site is analyzed as semi open spaces, indoor spaces, and defined open spaces.

3.1 Components of Circulation Paths in Public Buildings

As it has been mentioned in previous chapter, there are accessibility standards that are organized according to all sizes and abilities of people. Horizontal and vertical circulation spaces are examined in terms of standards that cover the components of these spaces.

3.1.1 Horizontal Circulation

Horizontal circulation consists of components like corridors and doors. These elements give horizontal access within a space and support the continuity of circulation in the buildings. Beirne (2003) defines the horizontal circulation as:

"... all walking areas on all floors of a building which are required for physical access to some space including the features like corridors, lobbies, verandas, porches, doors, entrance foyers, and balconies" (Beirne, 2003; Elottol, 2011, p.226).

In this study, horizontal circulation has been examined with the components which are;

- i. Parking spaces,
- ii. Pavements,
- iii. Main entrances,
- iv. Entrance halls,
- v. Corridors,
- vi. Internal doors and passageways.

These elements are classified according to their types and dimensions.

3.1.1.1 Parking Spaces

For an easy access to buildings, it is better to have parking spaces or short period stops next to the buildings' entrances. From car parking areas to pavements, it is expected to have accessible routes. (See Figure 9) "Designated accessible parking space(s), whether external or internal, should be provided within 30m of the main accessible entrance and/or any other accessible entrances" (N.A, 2004, p.14).

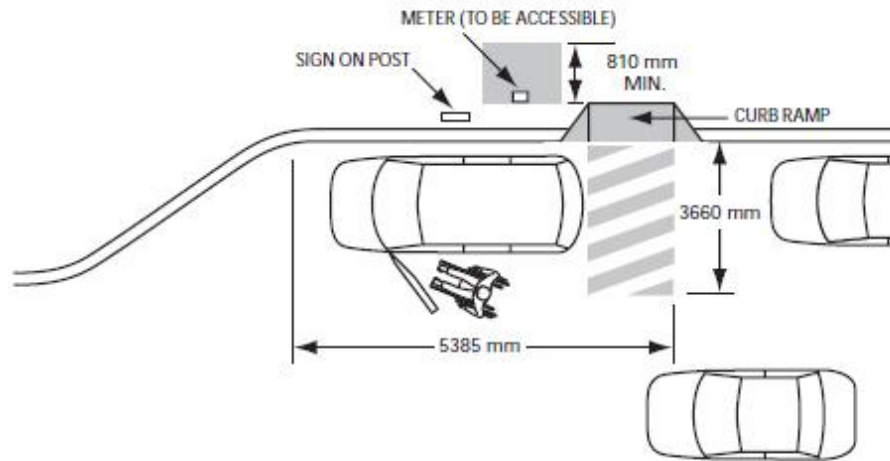

Figure 9: Car parking area near the entrance (N.A, 2004, p.14).

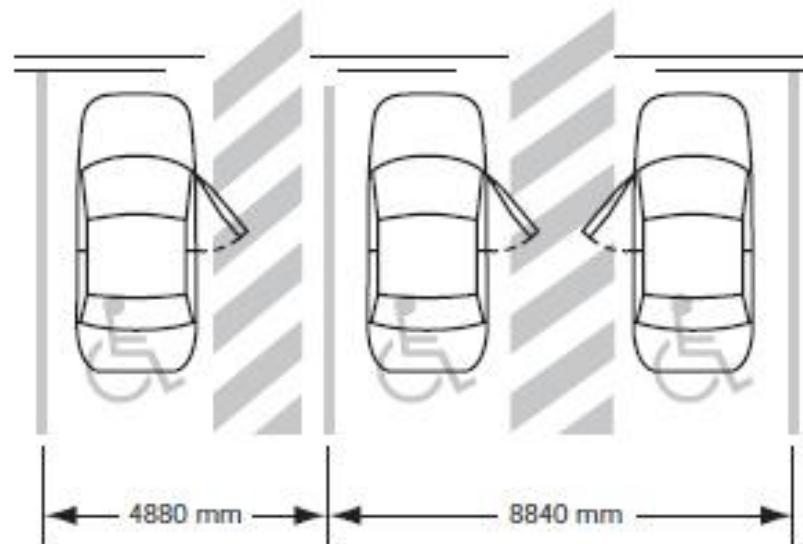

Figure 10: Car parking area near the entrance (N.A, 2004, p.14).

ADA standards about parking spaces are expected to be in the limits of 2895mm to 2440mm for one vehicle (Department of Justice, 2010).

London Centre for Accessible Environments, Designing for Accessibility Guide given the minimum measurements about parking spaces as 4800mm to 2400mm for one vehicle (BA, 2004).

3.1.1.2 Pavements

Pavements provide secure walking routes for people at the outside of the buildings. However, as there is level difference between the road and the pavement or sidewalk,

there should be an easy access for the people who have mobility problems from the disable car park space to the main entrance of the building.

"All entrance paths/sidewalks in a public right of way and/or walkways for pedestrians and persons using mobility aids must be of firm, level, and non-slip materials and are recommended to be a minimum of 1675 mm wide to allow two wheelchairs or scooters to pass one another. In no case should sidewalks be less than 1525 mm wide where two-way traffic is expected"(N.A, 2004, p.8).

Designing for Accessibility Guide given standards for pavements as in below figures;

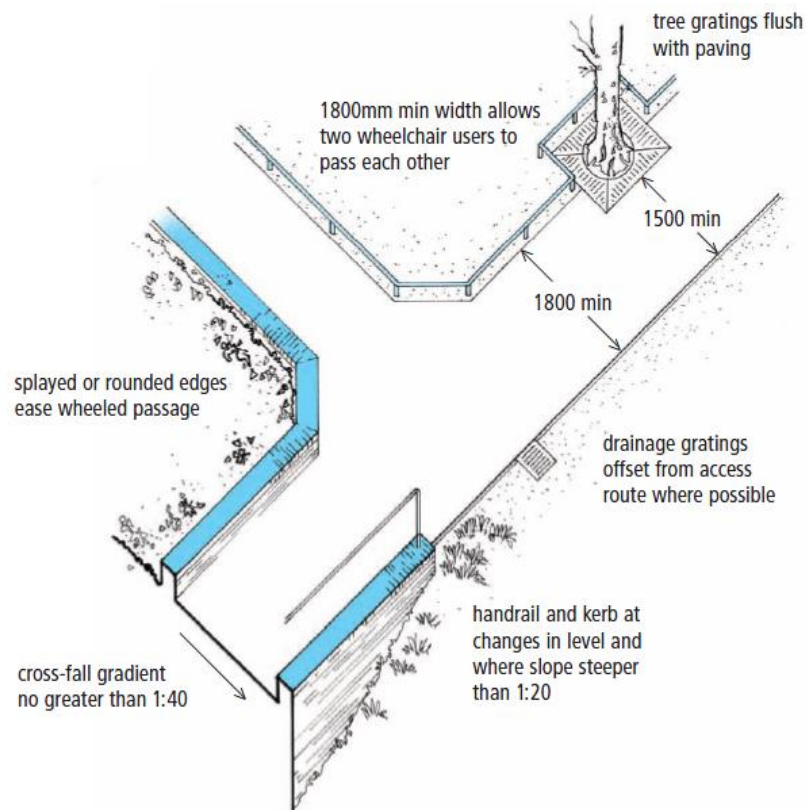

Figure 11: Pavement dimensions (BA, 2004, p.16).

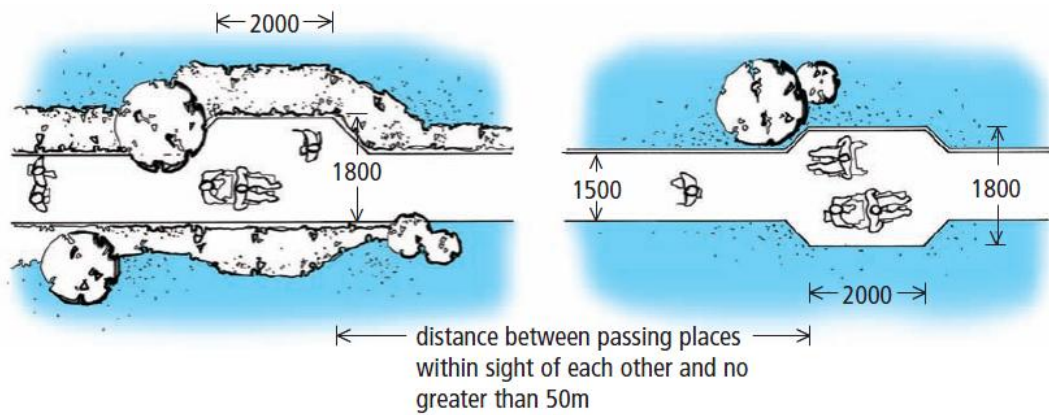

Figure 12: Passing places of pavements (BA, 2004, p.17).

ADA standards for pavements widths are minimum 1525mm for one wheelchair user and minimum 1675mm for two wheelchair users.

3.1.1.3 Main Entrances

Entrances are main entry points which are generally placed at the front facade of the buildings. The accessibility of the main entrance should be possible for disabled people. "In new buildings, the principal entrance should be accessible. In existing buildings, where it is not possible for the main entrance to be accessible, an alternative entrance should be provided which is accessible for all potential users" (BA, 2004, p.26).

By using canopies, entrances can be more secure for people. "All main entrances and other accessible entrances should be protected by a suitable canopy or overhang"(N.A,2004, p.51). Figure 13 shows sample measurement of a canopy. On the other hand, in order to reduce effect of the noise that comes from outside, the reception area should be located away from the entrance (BA,2004, p.33).

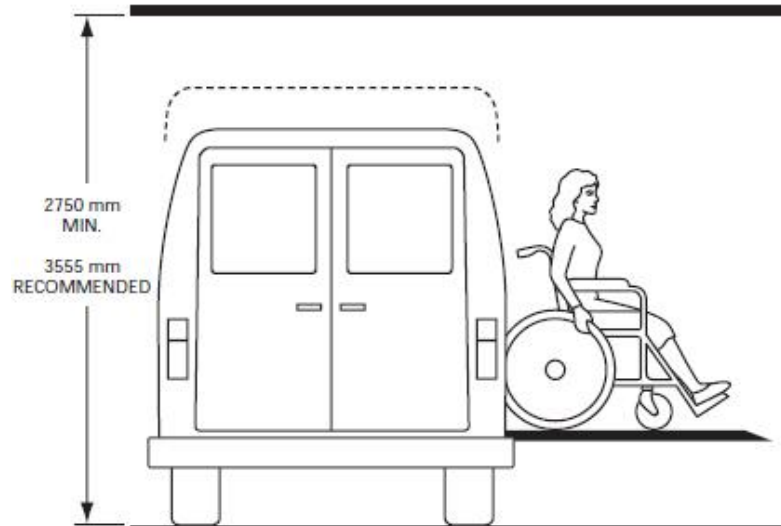

Figure 13: Canopy example for entrances (N.A, 2004, p.51).

"Main entrance doors and other accessible entrance and exit doors should be minimum of 915mm wide to allow safe passage of persons who use mobility aids" (N.A,2004, p.52).

The minimum width for access on the entrances is 815mm in the ADA standards (Department of Justice, 2010). The following manoeuvring clearances within doors and in front of doors are given below;

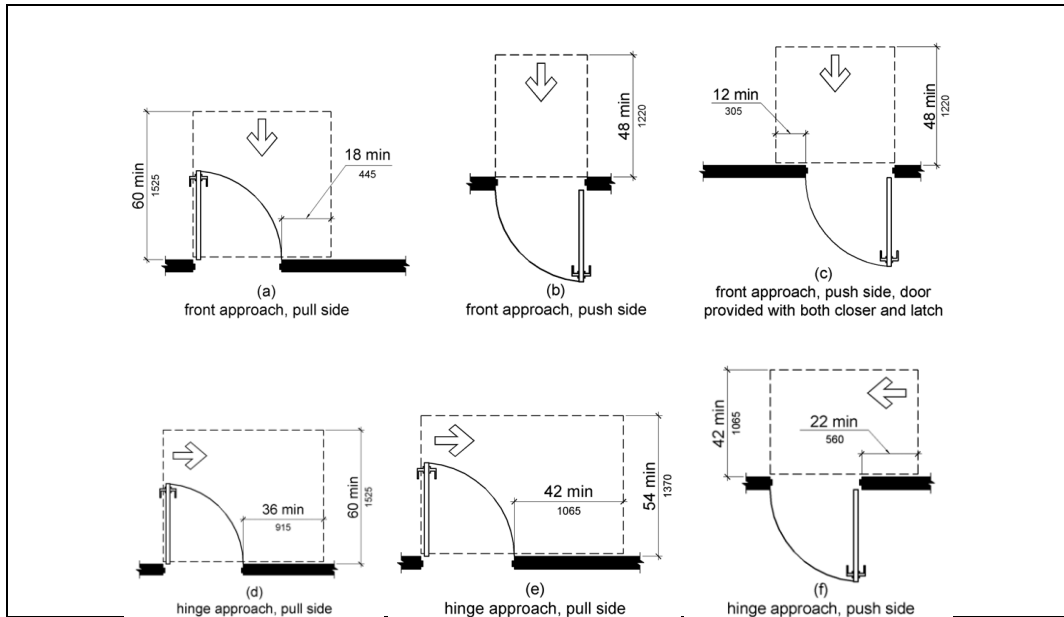

Figure 14: Manoeuvring clearances at manual swinging doors and gates (Department of Justice, 2010, p.122).

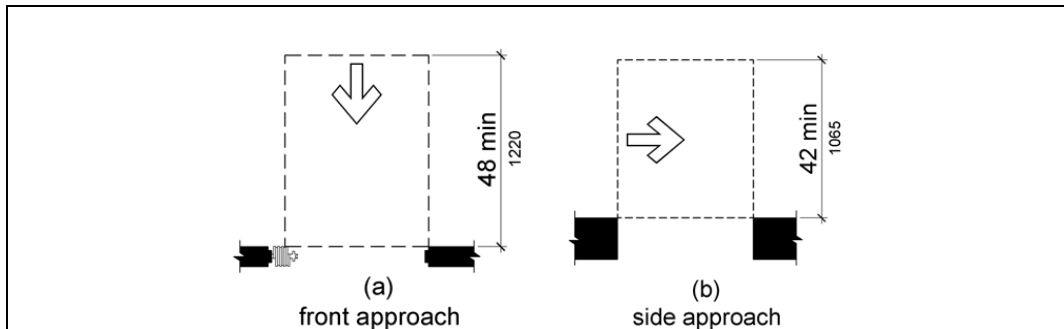

Figure 15: Manoeuvring clearances at doorways without doors, sliding doors, gates, and folding doors (Department of Justice, 2010, p.123).

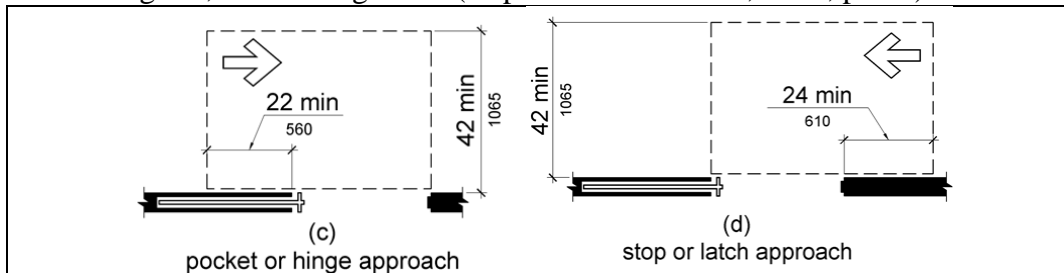

Figure 16: Manoeuvring clearances at doorways without doors, sliding doors, gates, and folding doors (Department of Justice, 2010, p.123).

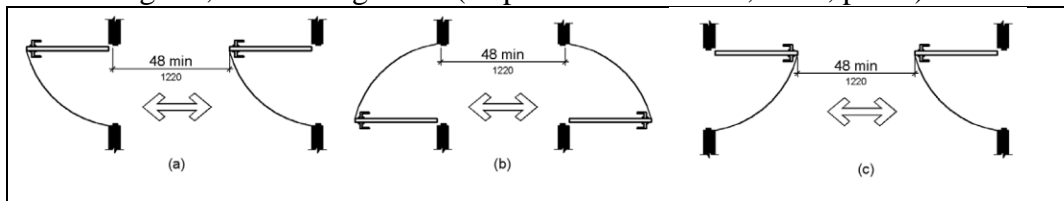

Figure 17: Doors and gates in series (Department of Justice, 2010, p.125).

3.1.1.4 Entrance Halls

Entrance hall is the space that begins from the entrance door and aids people to understand how they can reach others' spaces. It is fundamental for circulation of the building. Because, this space plays an important role about how people perceive the whole building. Information boards and signs in that area are beneficial for perception as well. Moreover, functions of the building such as, stairs, lifts, information desks, and restrooms should be visible and easily perceptible.

"All interior routes from accessible entrances to accessible exits should be safe and easy to use by persons with varying disabilities, including persons requiring mobility aids, and persons with vision or cognitive limitations. Such routes should be clearly identified and logical in layout" (N.A, 2004, p.51).

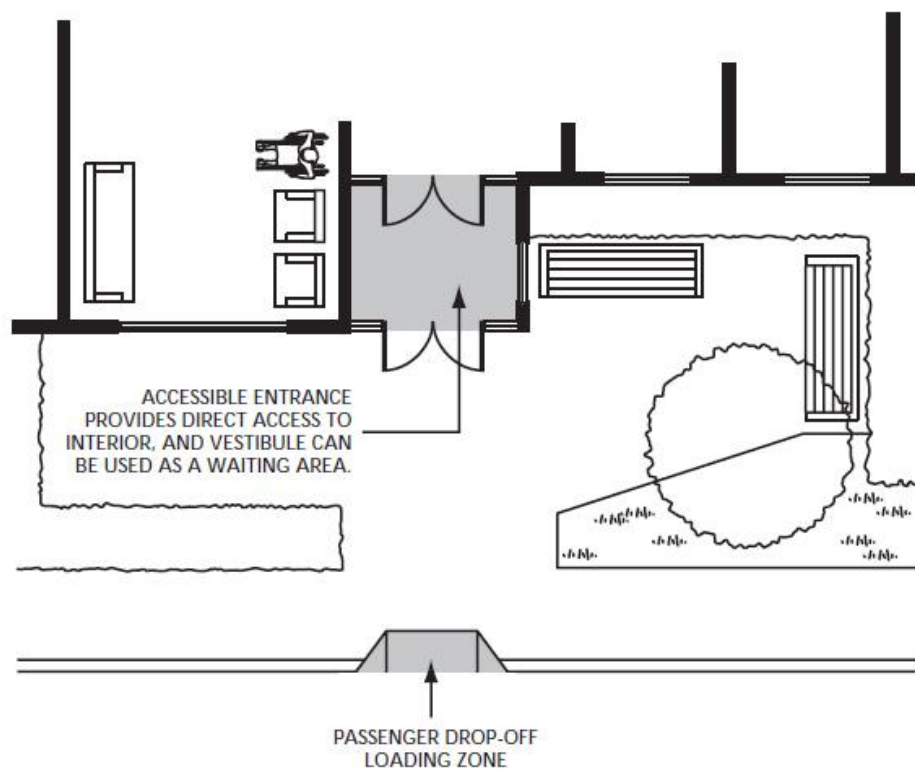

Figure 18: Entrance hall plan view (N.A, 2004, p.54).

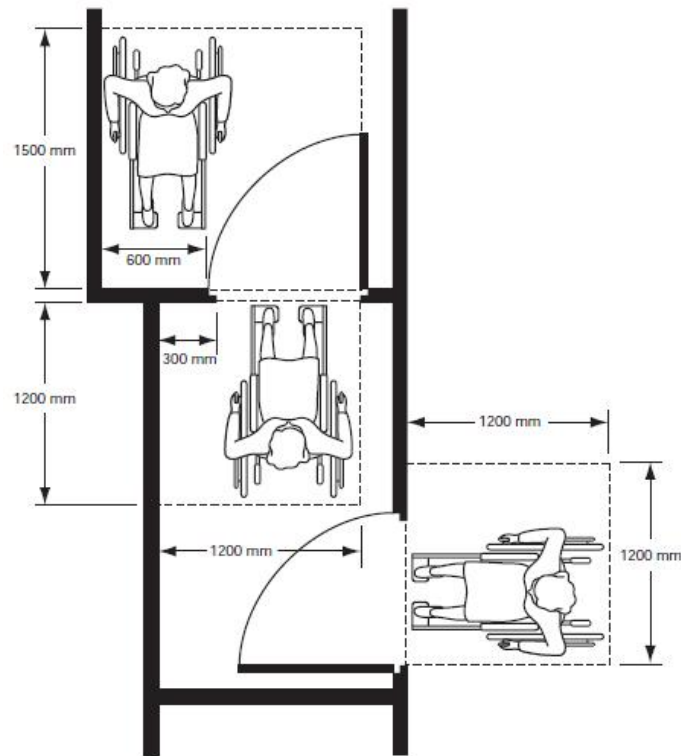

Figure 19: Entrance hall (N.A, 2004, p.57).

The flooring material can be textured to distinguish this space from others; slippery floor surfaces can cause hazards.

If there is no entrance hall in a building, people may not perceive the organization of the building. As a result, this can cause the quality of the circulation in the building to reduce. "Well-designed entrances foyers provide a transition from the outside to the inside, and can help orientate people once inside the building" (BA, 2004, p.33).

See Figure 21.

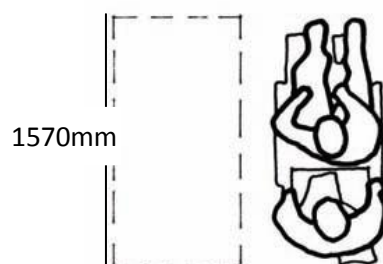

Figure 20: Necessary space for wheelchair user and assistant (BA, 2004, p.24).

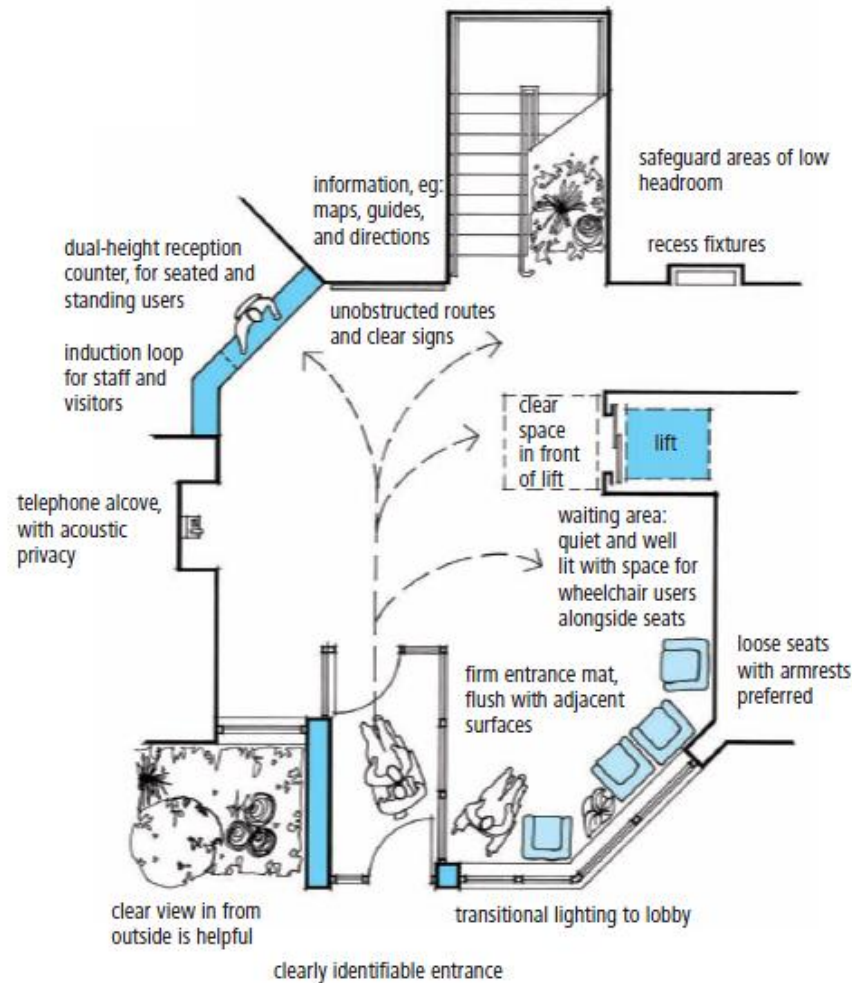

Figure 21: Accessible entrance hall (BA, 2004, p.33).

3.1.1.5 Corridors

Corridors are places as linear circulation paths which connect spaces to each other in the buildings. Generally internal doors open towards the corridors in public buildings. Corridors define the circulation routes for people. Narrow and long corridors can tire people and may cause them to lose their ways. Instead of these kinds of corridors, preferring wide and short corridors is significant for the functionality of circulation. The appropriate corridor widths for limited abilities including wheelchair users and other people like healthy people, parents with their babies on strollers are shown in Figure 22.

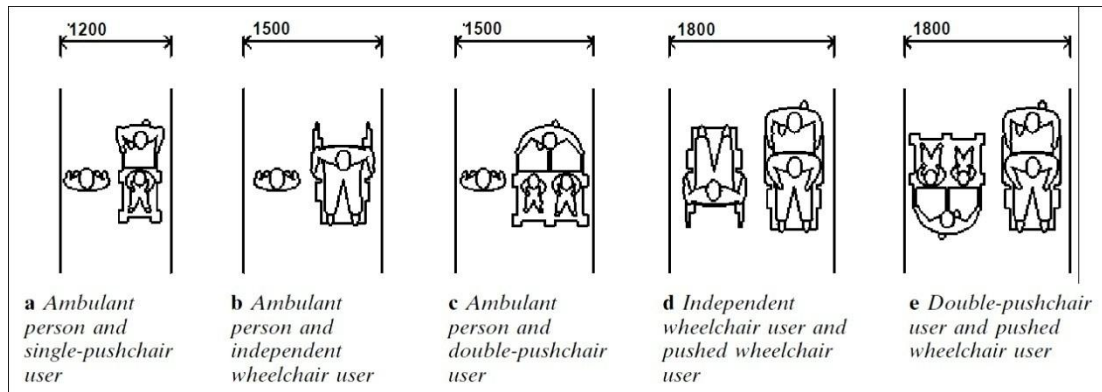

Figure 22: Corridor widths (Goldsmith, 2000, p.41).

"It is recommended that high use accessible public corridors and paths of travel should be a minimum of 1100 mm wide, with turning spaces at least 1600 mm in diameter, every 20 m, to permit the free movement of persons using mobility aids" (N.A, 2004, p.59).

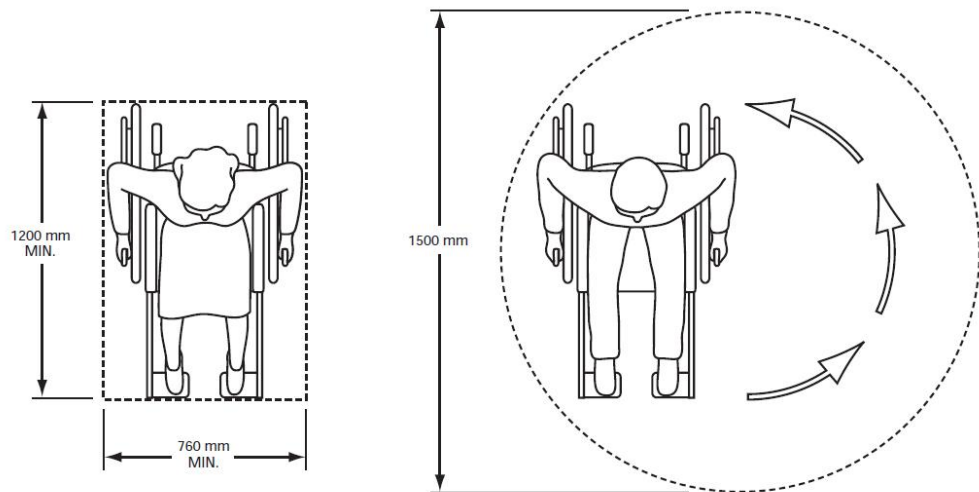

Figure 23: Dimension of wheelchair (N.A, 2004, p.58).

"In a well-planned building, corridors convey information about a building and assist with circulation around it" (BA, 2004, p.35).

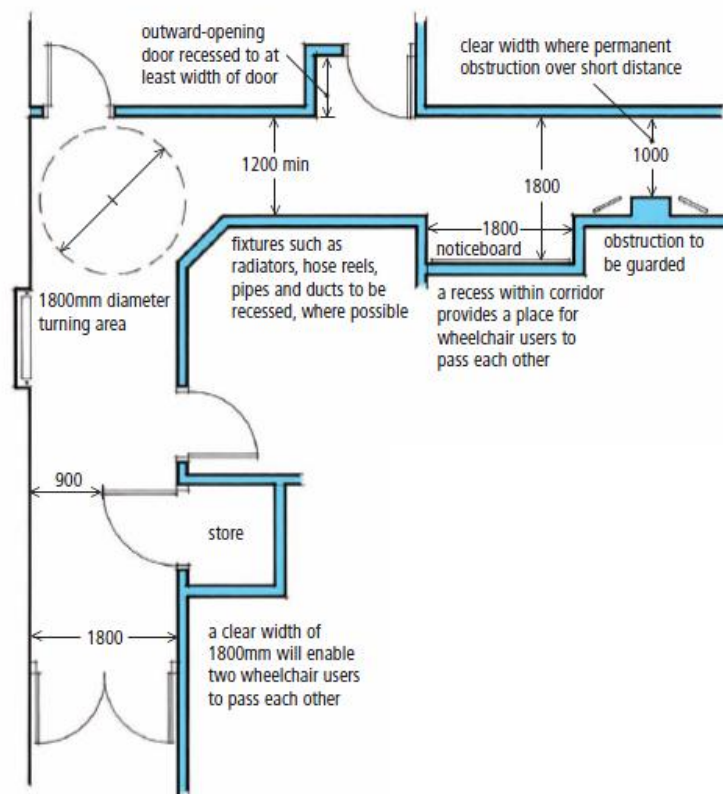

Figure 24: Moving trough corridors (BA, 2004, p.35).

Usually, at the starting point of the corridors, there are useful signs that orient people. If corridors are narrow in a building, doors should be wider.

In order to provide easy access and escape along the corridors, they should be designed simple, wide, safe, and as empty as possible (BA, 2004, p: 35-36).

ADA standards for corridors are; minimum width 915mm, minimum turning space 1525mm x 3050mm (Department of Justice, 2010).

Siedle (1996) mentioned about accessible design criteria of corridors as following figure;

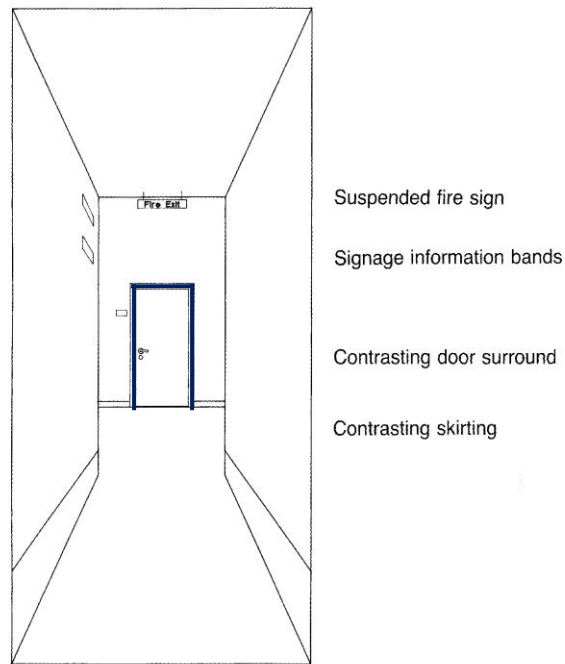

Figure 25: Sample image about corridor signs (Siedle, 1996, p.95).

3.1.1.6 Internal Doors and Passageways

Internal doors and passageways are openings that connect a closed area of the building to general-use areas. Sometimes, passageways are connected to different spaces without doors like corridors and common-use areas in public buildings.

"The main consideration regarding a door is whether it is actually necessary, or whether it could be 'designed out'. If the door is required and is on a main circulation route; or provides access to a key facility or service, ease of use is a priority" (BA, 2004, p.37). Internal doors had better contain information signs on or next to themselves. If these signs are placed according to different perceiving levels, they can easily be perceptible to all people. In following figures there are samples of door signs.

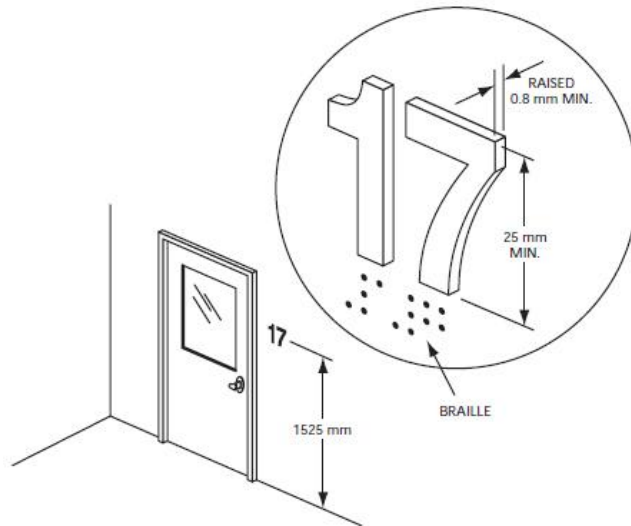

Figure 26: Sign next to door (N.A, 2004, p.85).

If double doors exist, at least one leaf should have 810 mm wide clear aperture for access (N.A, 2004, p.52).

"In existing buildings, where it is not possible to achieve 800mm, internal doors should provide a minimum 750mm effective clear width (or 775mm as against 825mm for doors at right angles to corridors narrower than 1200mm)" (BA, 2004, p.37).

ADA (2010) standards for minimum clear door widths are as follows;

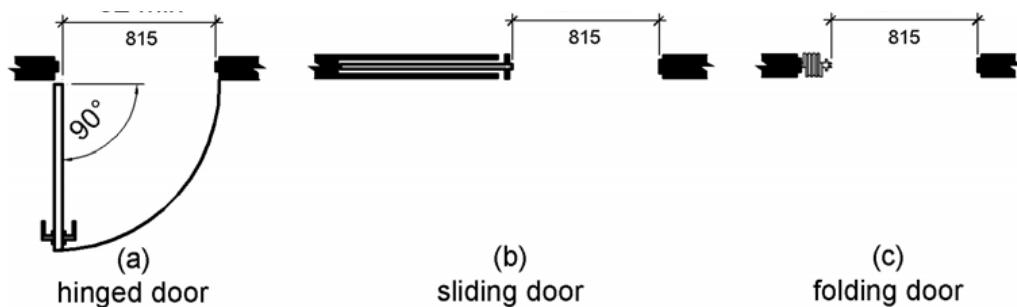

Figure 27: Clear width of door (Department of Justice, 2010, p.120).

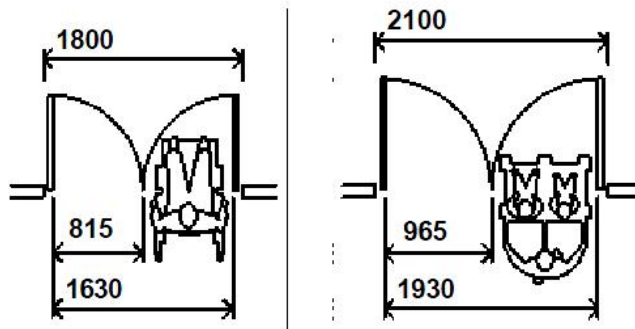

Figure 28: Internal accessible door widths (double leaf) (Goldsmith, 2000, p.46).

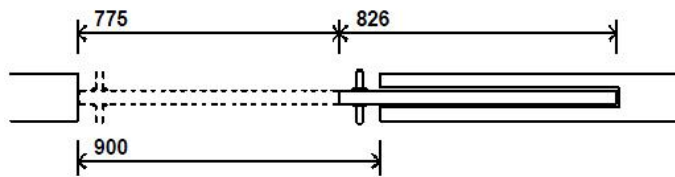

Figure 29: Internal accessible sliding door width (Goldsmith, 2000, p.45).

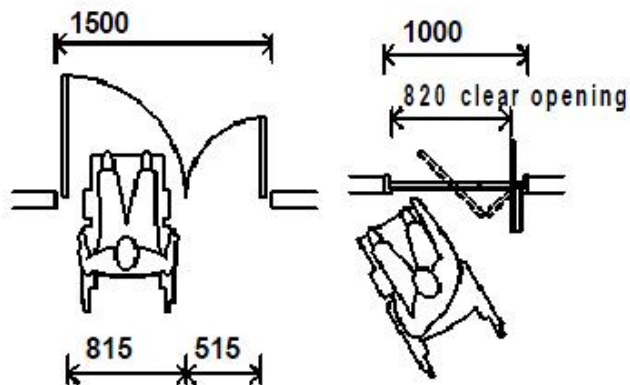

Figure 30: Clear openings for different types of doors (Goldsmith, 2000, p.46).

"Particularly where doors are heavy, consideration should be given to providing automatic opening, electromagnetic catches which hold doors open or closers linked to fire. "Door handles should be easily gripped and opened with one hand (BA, 2004, p:37-38).

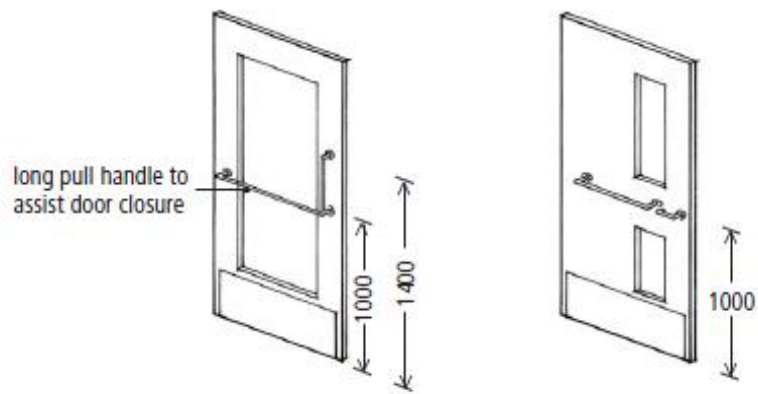

Figure 31: Height of door handles (BA, 2004, p.31).

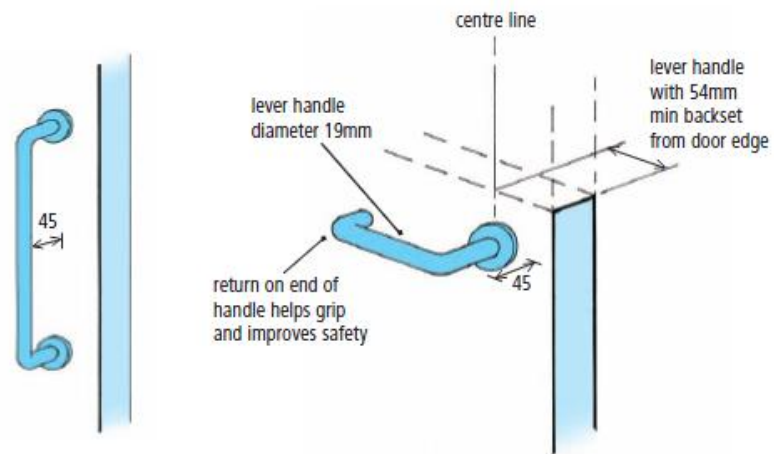

Figure 32: Details of door handles (BA, 2004, p.31).

" Fully glazed sidelights at exterior entrances or in interior vestibules, as well as fully glazed screens elsewhere, should be clearly identifiable so as not to constitute a hazard for persons with visual limitations" (N.A, 2004, p.55).

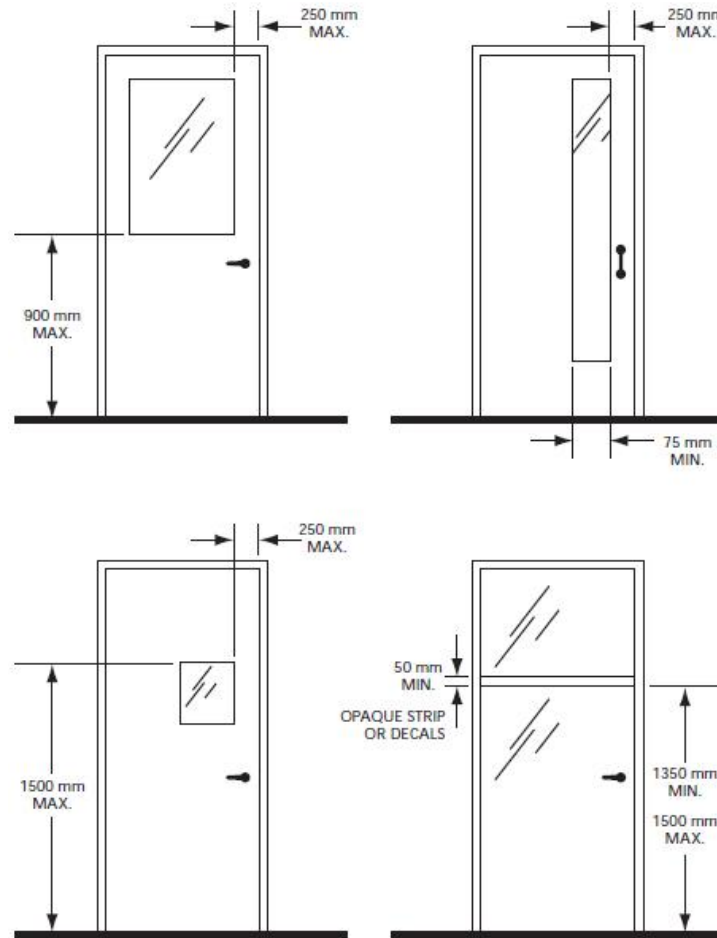

Figure 33: Partially glazed doors (N.A, 2004, p.55).

3.1.2 Vertical Circulation

Vertical circulation frames the vertical movement elements in the building. These elements can connect one space to another or can link floors within a building. They are significant linkers between spaces and they should give access to all people. Beirne (2003) defines vertical circulation as; "... all walking areas and mechanical tools installed in all floors of a building required for vertical physical access to some space including staircases, ramps, elevators and escalators" (Beirne, 2003; Elottol, 2011, p.226).

In this study, vertical circulation has been examined with the components which are;

- i. Steps and stairs,
- ii. ramps, and
- iii. lifts.

These elements are classified according to their types and dimensions.

3.1.2.1 Steps and Stairs

Steps and stairs are building's components, which provide access from one level to another or one floor to another. However, if the measurements and features are not accessible, these elements may become main handicaps for people. Their measurements should comply with standard measurements. Treads, risers and nosing, each of them has an important role on accessibility to a space. To minimize the risk of hazards, features of these elements may fit with following characteristics. Also, it should be kept into mind that stairs are one of the main preferences for vertical circulation especially in case of a danger. If disabled people do not have a major movement problem, their choice can be stairs as well. Moreover, in some sites stairs are the only choice. Therefore, accessibility of stairs should be designed carefully(Siedle, 1996).

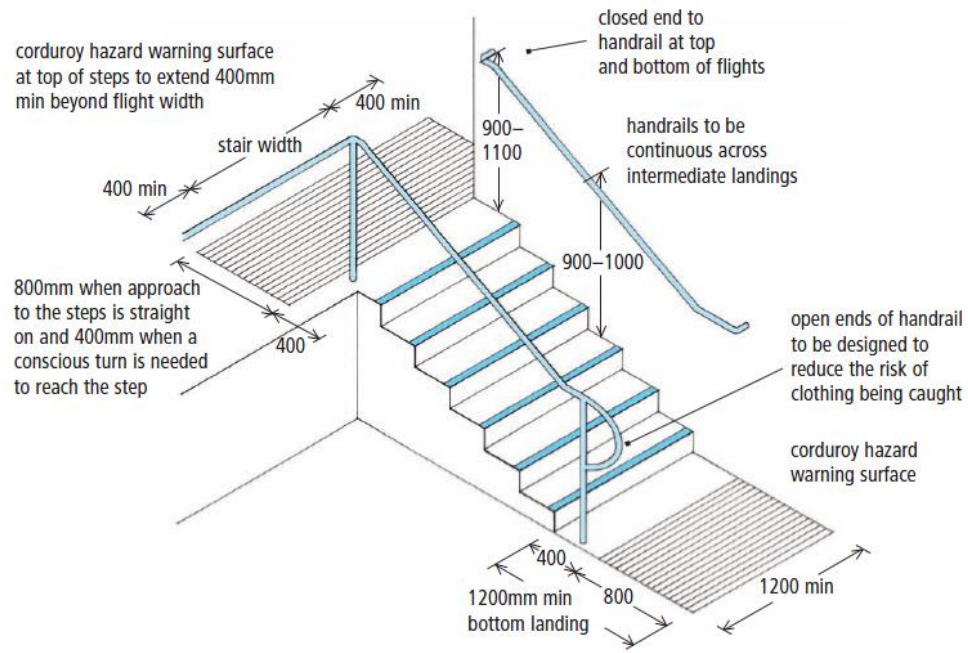

Figure 34: Sample of accessible stair (BA, 2004, p.23).

On the other hand, generally transportation services and public buildings have lots of stairs. There are regulations about the height and the number of the risers.

"Flights should contain no more than 12 risers between landings or, exceptionally, up to 16 risers in small buildings where space is restricted. The rise of steps should be between 150 and 170mm, except in existing buildings with space constraints, where a higher rise may be acceptable. Spiral stairs and tapered treads are not recommended. Open risers should not be used. Avoid single steps" (BA, 2004, p.40).

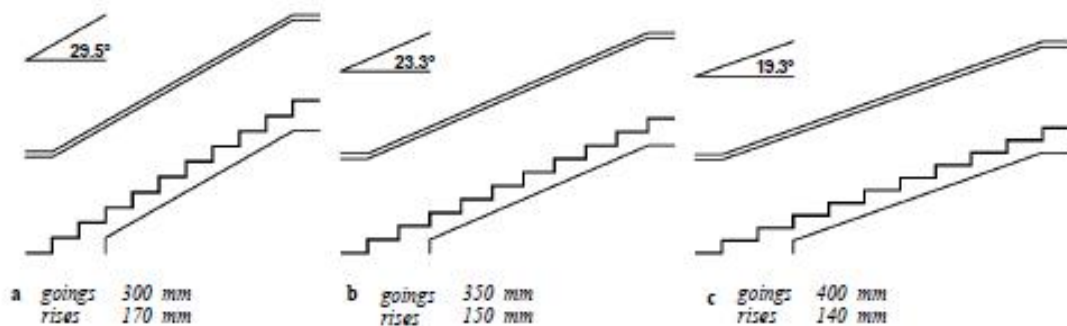

Figure 35: Stair models (Goldsmith, 2000, p.58).

Department of Justice announced the measurement limits as a regulation. Tread's depth and height and even the slope measurement are calculated carefully."Treads' minimum depth shall be 280 mm. Risers' height may be minimum 100mm and maximum 180 mm. Treads' slope should not be steeper than 1:48" (Department of Justice,2010,p.153). In addition, London Centre for Accessible Environments, (2004) arranges standards about risers and treads as in Figure 36.

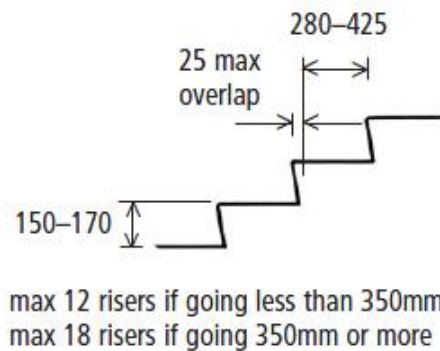

Figure 36: Risers and treads (goings) (BA, 2004, p.24).

Department of Justice also gave the measurements of the radius of curvature as $\frac{1}{2}$ inch (13 mm). Also the angle under the tread from vertical was given as 30 degrees maximum. Another important measurement was the permitted projection of nosing extension as $1\frac{1}{2}$ inches (38 mm) maximum. Moreover the underside of the leading edge should be curved or bevelled (Department of Justice, 2010, p.153).

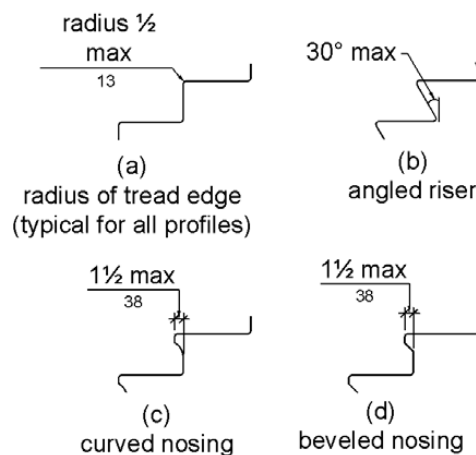

Figure 37: Stair nosing (Department of Justice, 2010, p.153).

There should be a contrast between surfaces of treads and tread nosing (Department of Justice, 2010, p.153). Difference between treads and nosing should be perceptible. Also, tread surfaces should not be slimy and rough. With this sensitivity, an accessible example of stair is shown as below;

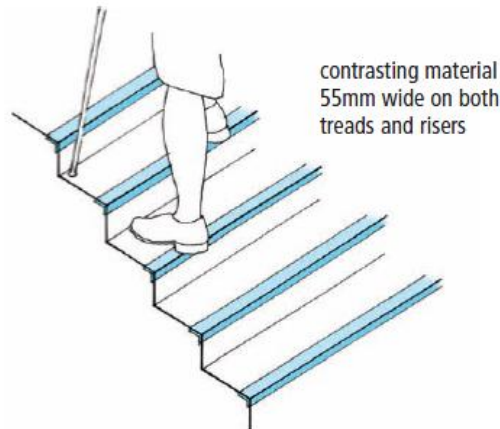

Figure 38: Nosing with contrasting material (BA, 2004, p.24).

It is needed to have a handrail to help people when they use stairs to reach a different level. The continuity of handrails is significant on the flights and landings. "Handrails should be easy to grip and provide good forearm support for people who are unable to grip" (BA, 2004, p.25). Goldsmith (2000) also gives following measurements about accessible handrails.

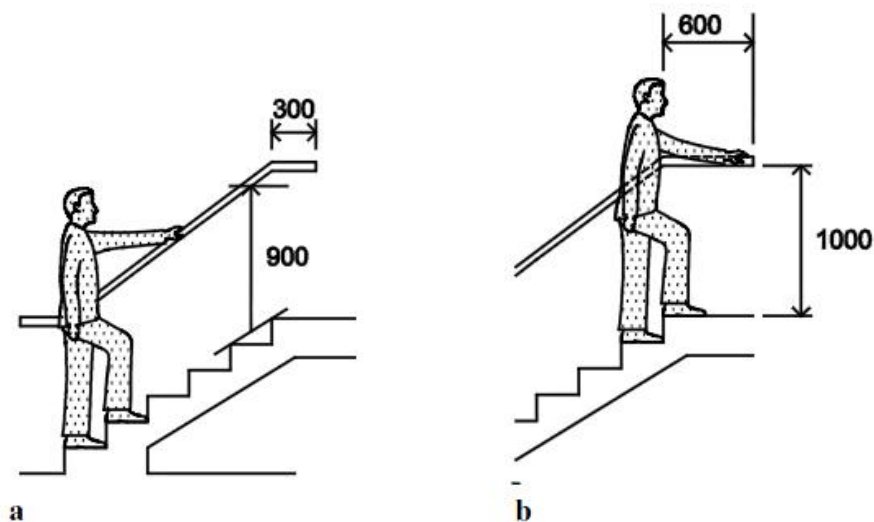

Figure 39: Handrails to stairs (Goldsmith, 2000, p.59).

3.1.2.2 Ramps

If ramps have suitable measurements, they can eliminate barriers, which are caused by steps and stairs; hence they may give access to people. They are usually used in entrances to access in a building. Also, they can be used to connect different levels of buildings.

a. Indoor Ramps

"Interior ramps should have a maximum slope of 1 in 12; however, a slope of 1 in 15 is preferred". Between two landings, the maximum length of any ramp should be 9 m (N.A, 2004, p: 61). In order to ease the difficult lives of wheelchairs, ramps are one of the best methods. Ramps eliminate the change in level and make it more accessible for wheelchairs, parents, parents, with steps (Siedle,1996,p:51). Figure 35 shows the criteria about slopes of ramps.

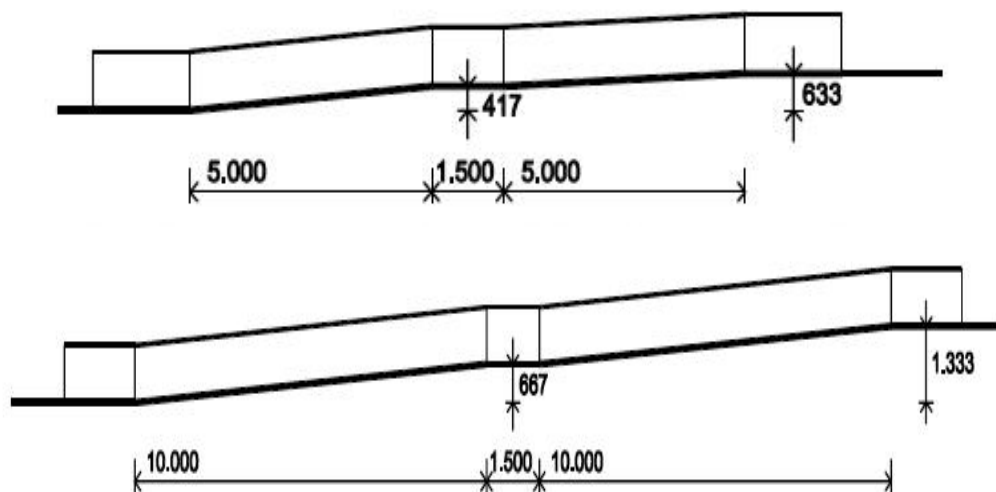

Figure 40: Sample ramp sections (Goldsmith, 2000, p:60).

The last but not the least about ramps are their surfaces. Special non-slip materials should be used. Even the handrails of these ramps should be carefully considered before it is built. The general measurement for handrails is no less than 900mm and no more that 1100mm. Also the width should be 1015mm. There is another requirement which is the necessity of handrails on both sides; "handrails are required

on both sides of ramps and should extend at least 300 mm beyond the head and foot of the ramp" (N.A, 2004, p.62). (See Fig. 36)

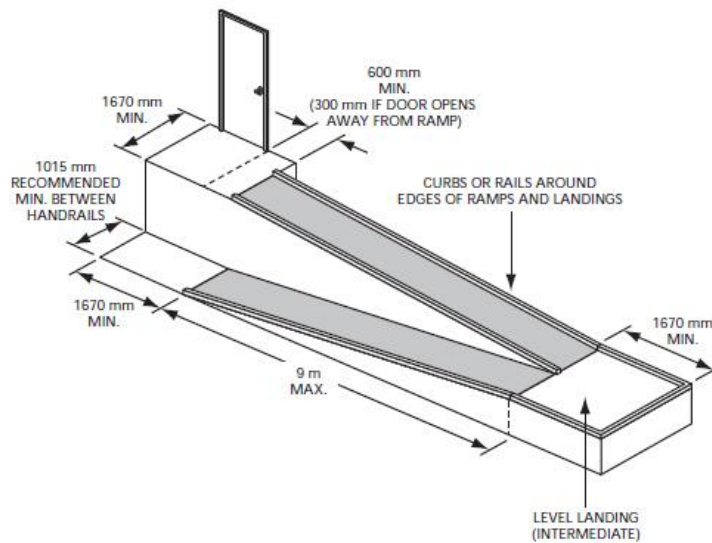

Figure 41: Ramp with intermediate landing (N.A, 2004, p.10).

"Where the change in level is more than 300mm, two or more clearly signposted steps should be provided in addition to the ramp; where the change in level is not more than 300mm, a ramp should be provided instead of a single step"(BA, 2004, p.40).

b. Outdoor Ramps

Outdoor ramps are significant connections between roads and pavements, also between pavements and entrances. "Where level access is not achievable, ramps enable wheelchair users and people with pushchairs to overcome level changes"(BA, 2004, p.21).

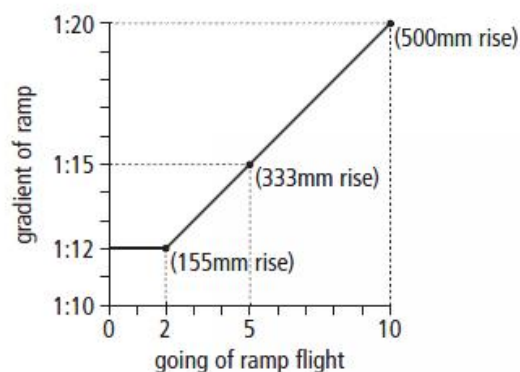

Figure 42: Ramp gradients (BA, 2004, p.21).

As indoor ramps, outdoor ramps "... must be no steeper than 1:12, with individual ramp sections no longer than 9m. Ramp widths should be a maximum of 1100 mm and a recommended minimum of 1015 mm between handrails, to allow persons using mobility aids to move easily and to grasp the handrails if required. Ramps with slopes between 1:20 and 1:12 require handrails on both sides as an aid to mobility" (N.A,2004,p.10).

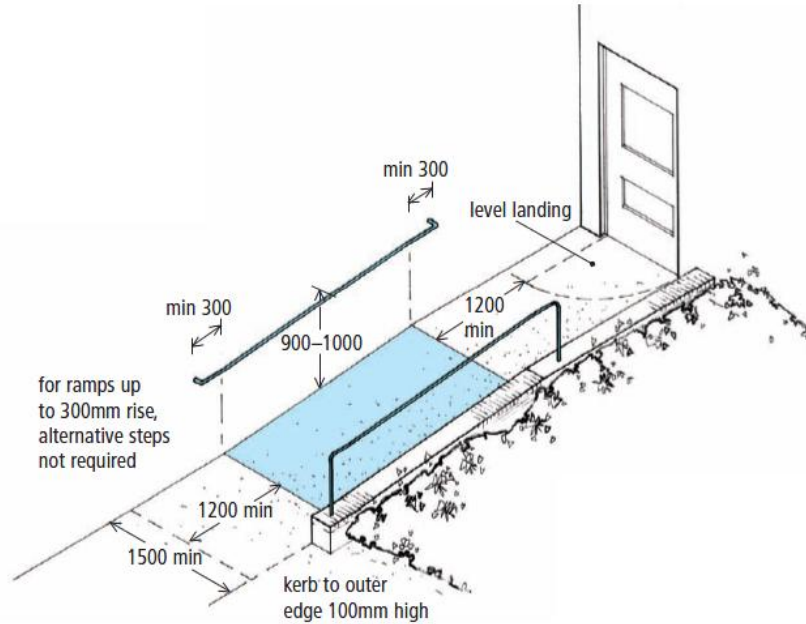

Figure 43: Short rise ramp design (BA, 2004, p.21).

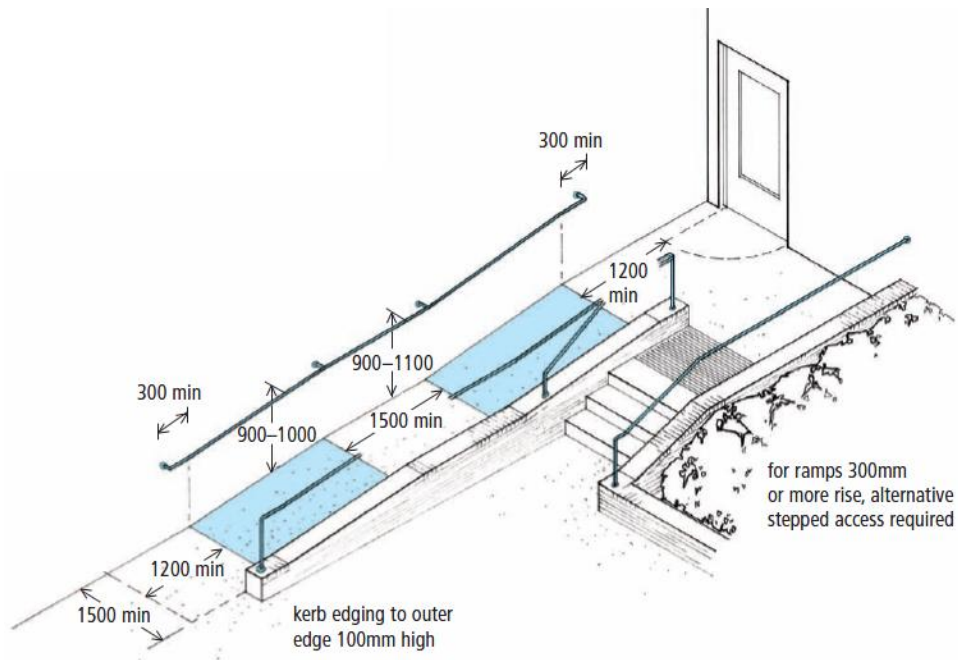
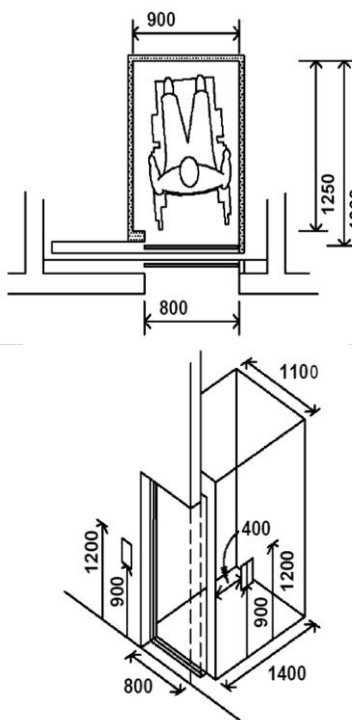



Figure 44: Ramp design with adjacent steps (BA, 2004, p.22).

3.1.2.3 Lifts

Lift is one of the elements that provide vertical circulation within floors of building. If it has suitable conditions and dimensions, it can give access to all people. There are minimum standards about lifts which are arranged by related organizations and governments. Also, there are various types of lifts which are suitable by public use. Table 3.1 shows the dimensions and photos of lift sorts. Lifts are one of the main preferences of vertical circulation. Even the fittest members of population use lifts rather than stairs owing to its comfort, speed and easiness. Therefore accessibility to lifts are really important. Lifts are sometimes installed outdoors which need more maintenance because of dirt and vandalism. Lifts can be replaced by a ramp if it is not too high to install. (Siedle, 1996, p.72)

Table 5: Types of lifts.

| TYPES OF LIFTS | |
|--|--|
| A. Person-Passenger Lifts | |
|  <p>Drawings of Person- passenger lift 1 (Goldsmith, 2000, p.63).</p> |  <p>Person- passenger lift 1(URL 3.2).</p> |

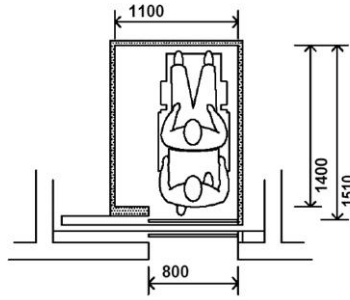

Drawings of Person- passenger lifts 2(Goldsmith, 2000, p.63).

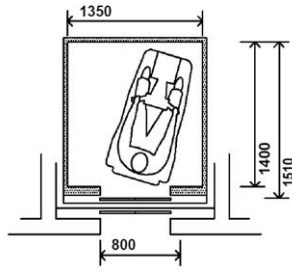

Drawings of Person- passenger lifts 3(Goldsmith, 2000, p.63).

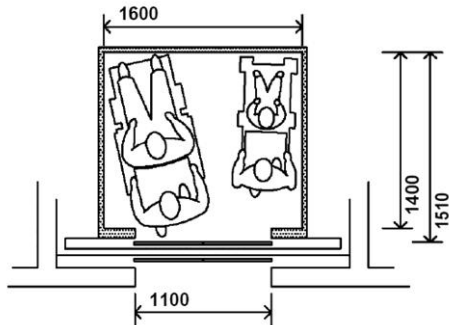

Drawings of Person- passenger lifts 4(Goldsmith, 2000, p.63).

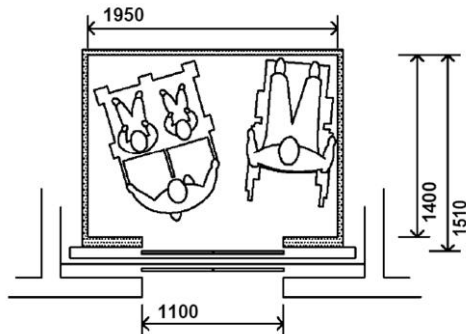

Drawings of Person- passenger lifts 5(Goldsmith, 2000, p.63).



Person- passenger lift 2 (URL 3.3).



Person- passenger lift 4 (URL 3.4).

B. Platform Lifts

Through-Floor Lift

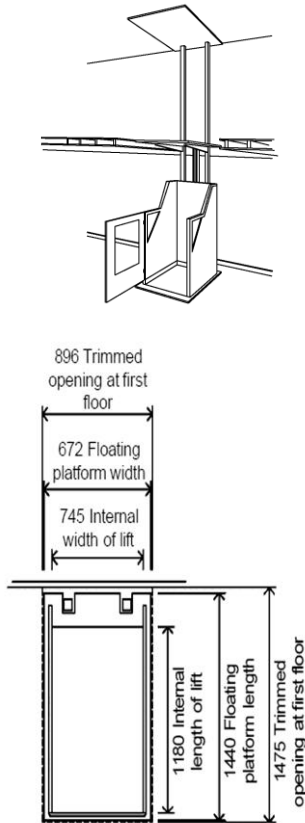

Drawings of Through-floor lift (Goldsmith, 2000, p.64).



Through-floor lift (URL 3.5).

Retractable Access Lift

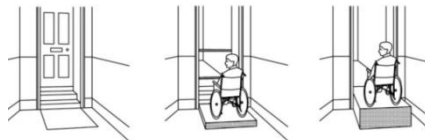

Drawings of Retractable access lifts (Goldsmith, 2000, p.64).



Retractable access lifts (URL 3.6).



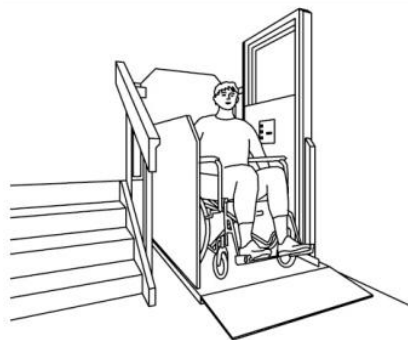



Internal Wheelchair Platform Lift

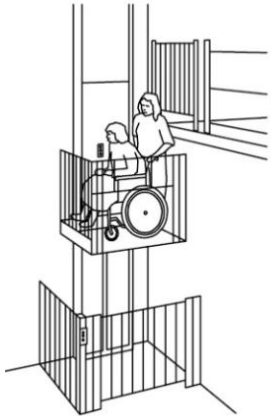

Drawing of internal wheelchair platform lift (Goldsmith, 2000, p.65).

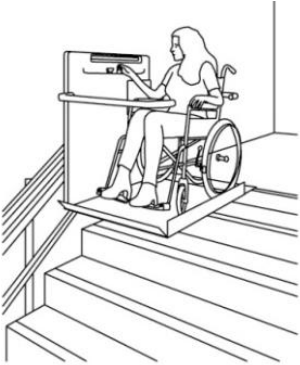

Internal wheelchair platform lift (URL 2.8).

| | | |
|---|--|--|
| <p>External Wheelchair Platform Lift</p> |  <p>Drawing of External wheelchair platform lift (Goldsmith, 2000, p.65).</p> |  <p>External wheelchair platform lift (URL 3.7).</p> |
| <p>C. Stair Lifts</p> | | |
| <p>Stair Wheelchair Platform Lift</p> |  <p>Drawing of Stair wheelchair platform lift (Goldsmith, 2000, p.65).</p> |  <p>Stair wheelchair platform lift 1 (URL 3.8).</p>  <p>Stair wheelchair platform lift 2 (URL 3.9).</p> |
| <p>Chair Stair Lift</p> |  <p>Drawing of chair stair lift (Goldsmith, 2000, p.65).</p> |  <p>Chair Stair Lift 1 (URL 3.10).</p> |

3.2 Categories of Circulation Paths in Public Buildings

a. Outdoor space

Between exterior and interior spaces there is an important linker space which is named as "entrance space". Starting with car parking till entrance of the building, one of the significant areas of the building that interior designers should be aware of is entrance space. Providing the circulation relation is one of the initial responsibilities of interior designers. Outdoor spaces are significant parts of circulation, which are expected to be controlled and designed with response.

Moreover, there are various types of organizations on the outdoor spaces of buildings. Especially historic buildings have original characteristics on these spaces. They generally have well defined identity on entrance routes. While analyzing a public historic building, it is very noticeable that they are different from other buildings. Most known rule about historic buildings is respecting the originality of buildings while adapting a new design. First, it has historical, cultural, functional, economic values, and has lots of visitors from other countries. If it has a good condition about circulation; giving easy access to all, there is no problem to solve. However, if there are circulation problems in that kind of building, it should immediately be solved by designers. At this point, there are many regulations, standards, and rules which have been enacted by governments and organizations. So, designers are expected to be sensitive on them.

b. Semi open space

Circulation paths of semi open spaces are generally linkers among indoor spaces, linkers between indoor spaces and outdoor spaces, or linkers between indoor spaces and defined open spaces. Formation of semi open spaces are generally like a corridor,

and their functions are also for circulation. It is significant to provide accessibility in these circulation paths, because of their functions and locations.

c. Indoor space

Movement of people in the spaces is one of the significant factors that affect the design. Design should not be a barrier for people, and it is expected to give permissions for movement around spaces easily. Stephen (2009) explains the interior circulation in the buildings as:

"A term describes how visitors make their way through the facility. What pathways do they take? Do visitors circulate the way the designers intended? Do visitors miss key exhibits because of the architectural design of the facility? Which direction do visitors turn when they reach choice points? Do visitors have a circulation strategy (e.g., "Turn right and follow the perimeter") or do they simply wander more or less aimlessly?"(Stephen, 2009; Elottol, 2011, pp.226).

Stephen (2009) defines circulation in the building by using some factors that affect the movement of people. It is expected from interior architects to organize and design movement of interiors according to circulation standards. These circulation standards comprise the minimum movement areas in all spaces of building like, entrances, corridors, and staircases.

d. Defined open space

Circulation paths between defined open spaces (courtyards or backyards) and buildings had better comply with accessibility standards. It is also significant to provide accessibility in these spaces as interiors, because sometimes it is a must to use courtyards for some functions. Sometimes building functions like restrooms and staircases may be located in defined open spaces of the building. Transitional circulation between spaces can be corridors, steps, ramps, or lifts. These components of the circulation are emphasized separately.

3.3 Evaluation of chapter

This chapter focuses on accessibility standards, related with circulation paths of spaces in public buildings. Circulation paths are categorized into four spaces as; outdoor spaces, semi open spaces, indoor spaces and defined open spaces and the components of these circulation paths are analysed.

This categorization is beneficial to analyze buildings more systematically, in terms of different kind of spaces. Generally, standards of components have similar measurements in all spaces. For instance, there are general rules about buildings' ramps or stairs, and it shows similarities between indoor spaces and outdoor spaces. However, some conditions like open air, effect regulations about slip resistance on the ramps and stairs.

It is significant to access interior spaces of a building, and it is possible to provide this access, with continuity of accessibility on the circulation paths from outdoor spaces to indoor spaces. In order to analyse circulation paths of the selected buildings according to international standards, Table 6 was developed.

Also, Table 7 shows minimum accessible standards about components of circulation. This chart is composed by three accessibility regulations which are accepted world widely: Centre for Accessible Environments, Accessible Design Guidelines (City of Toronto), ADA Standards for Accessible Design. The given variations of evaluation aperture, at the end of the table, is accepted as evaluation apertures for case study.

According to these charts selected buildings are discussed under the title of accessibility and present useful analyses on potentiality and accessibility of a public space about accessibility standards.

Accessibility has been discussed under the case study analyses with the help of Table 7. Those assessments rely on worldwide standards and it is expected to be discussed parallel with information which is contained in the table.

The shown documents are considered through accessibility circumstances which should be considered as an important issue for all architect and designers. The proposed study hopefully will help designers on their projects through accessibility standards.

Table 6: Analysis table for selected buildings.

















| No | Building Name | Space Organization of the Building | Photos of the Building | | | | |
|--------------------------|------------------------------|---|---|---|--|--|-----------------------------------|
| | | | | | | | |
| | | KEY OF ORGANIZATION  door spaces  semi-open spaces Indoor spaces  Defined open spaces  Parking spaces  Pavements  Entrances  Lifts  Steps and stairs  Ramps  Entrance halls  Doors and passageways  Corridors/ pathways | | | | | |
| | | |  Circulation paths of outdoor spaces |  Circulation paths of semi-open spaces |  Circulation paths of indoor spaces |  Circulation paths of defined open spaces | General condition and suggestions |
| Parking Spaces | Horizontal circulation paths | Entrance halls | Entrance halls | Doors and passageways | | | |
| | | Doors and passageways | Doors and passageways | | | | |
| Pavements | | Corridors | Corridors | Pathways | | | |
| Outdoor ramps and stairs | Vertical circulation paths | Steps and stairs | Steps and stairs | Steps and stairs | | | |
| | | Ramps | Ramps | Ramps | | | |
| Entrances | | Lifts | Lifts | Lifts | | | |

Table 7: Table showing the measurements for evaluation of horizontal & vertical circulation components in terms of accessibility

| Measurements for evaluation of horizontal & vertical circulation components in terms of accessibility | | | | | | | | | | | |
|---|--|---|---|---|-----------------------|---|---|---|---|--|--|
| | Horizontal Circulation | | | | | | Vertical Circulation | | | | |
| | Parking Spaces | Pavements | Main Entrances | Entrance halls | Doors and passageways | Corridors | Steps and stairs | | Ramps | | Lifts |
| | | | | | | | indoor | outdoor | indoor | outdoor | |
| Centre for Accessible Environments (BA, 2004) | 4800mm x 2400mm (min) (for 1 vehicle) | Width: 1500mm (min) for 1 wheelchair users Width: 1800mm (min) for 2 wheelchair user | Approach space: 1065mm (min) Door width: 900mm (min) | - | Width: 750mm (min) | Width: 1100mm (min) Turning space: 1600mm (min) | Risers: 140mm-180mm (min-max) Max. 12 risers between landings (for indoors) Goings (treads): 300mm-400mm (min-max) Radius of curvature: 13mm (max) Contrasting materials on nosing: 55mm wide on both goings and risers Handrails height: 900mm-1000mm | Max. 18 risers: With min. risers and max. goings Risers: 100mm-175mm (min-max) Goings (treads): 300mm-425mm (min-max) | Max. length for a ramp: 9000mm Min. width of ramp: 1100mm Slope 1:12 (for 155mm rise) Slope 1:20 (for 500mm rise) Handrails on both side, height of handrails: 900mm Landings long: 1500mm (min) | Max. length for a ramp: 900mm Min. width of ramp: 1100mm Slope 1:12 (for 155mm rise) Slope 1:20 (for 500mm rise) Handrails on both side, height of handrails: 900mm Landings length: 1500mm (min) | Min. area for a lift: 900mmx1360mm Door width: 750mm (min) |
| Accessible Design Guidelines (City of Toronto) (N.A, 2004) | 5385mm x 3660mm (min) (for 1 vehicle) | Width: 1200mm (min) | Door width: 1100 mm (min) | Width: 1200mm (min) Approach from outside: 1200mmx1200mm (min) Door width: 750mm (min) Clear space for interior access: 1500mmx1500mm for 2 wheelchair users | Width: 915mm (min) | Width: 1100mm (min) Turning space: 1600mm (min) | Risers: 180mm (max) Goings (treads): 280mm (max) | Risers: 180mm (max) Goings (treads): 280mm | Max. length for a ramp: 900mm Min. width of ramp: 1015mm Max: slope: 1:12 | Max. length for a ramp: 900mm Min. width of ramp: 1015mm Max: slope: 1:12 | Min. area for a lift: 1500mmx1500mm Door width: 860mm (min) |
| ADA Standards for Accessible Design (Department of Justice, 2010) | 2895 mm x 2440mm (min) (for 1 vehicle) | Width: 1525mm (min) for 1 wheelchair users Width: 1675mm (min) for 2 wheelchair user | Width: 815mm (min) | - | Width: 815mm (min) | Width: 915mm (min) Turning space: 1525mmx 3050mm (min) | Risers: 100mm-180mm (min-max) Goings (treads): 280mm (min) Height of handrails: 865mm-965mm (min-max) | Risers: 100mm-180mm (min-max) Goings (treads): 280mm (min) Height of handrails: 865mm-965mm (min-max) | Min. width of ramp: 915mm Slope 1:12 (for 150mm rise) Max: slope: 1:8 Max. run of ramp: 760mm Landings length: 1525mm (min) | Min. width of ramp: 915mm Slope 1:12 (for 150mm rise) Max: slope: 1:8 Max. run of ramp: 760mm Landings length: 1525mm (min) Height of handrails: 865mm-965mm (min-max) | Min. area for a lift: 1370mmx1065mm Door width: 815mm (min) |
| Variations of Evaluation Aperture | 2895mm x 2440mm (min) | 1200mm (min) | 815mm (min) | 1200mm (min) | 815mm (min) | 915mm (min) | Risers: 180mm (max) Goings (treads): 300mm (max) | Risers: 100mm (min) Goings (treads): 400mm (max) | Max. length for a ramp: 900mm Min. width of ramp: 815mm Max: slope: 1:12 Height of handrails: 900mm | Max. length for a ramp: 900mm Min. width of ramp: 1015mm Max: slope: 1:12 Height of handrails: 900mm | Min. area for a lift: 900mmx1360mm Door width: 815mm (min) |

Chapter 4

EVALUATION OF ACCESSIBILITY IN SELECTED RE-FUNCTIONED PUBLIC HISTORIC BUILDINGS IN NORTHERN PART OF NICOSIA WALLED CITY

Selected public historic buildings on the "Walking Route" (Blue Line), in Northern part of Nicosia are investigated, in order to evaluate their accessibility in circulation. Ten public historic buildings that have cultural and historical functions are selected as case buildings from the Northern part of Nicosia Walled City. They are either museums or cultural centres which have many national and international visitors. These heritage buildings are significant part of culture and history of Cyprus. Tourists are very interested with Cyprus Culture and its historical background. In order to analyse the existing condition, observation by the author is the base of the methodology as qualitative study. Selected buildings are listed in Table 8 and their locations are shown in Figure 45.



Figure 45: Whole view of Nicosia Walled City (URL 4.1).

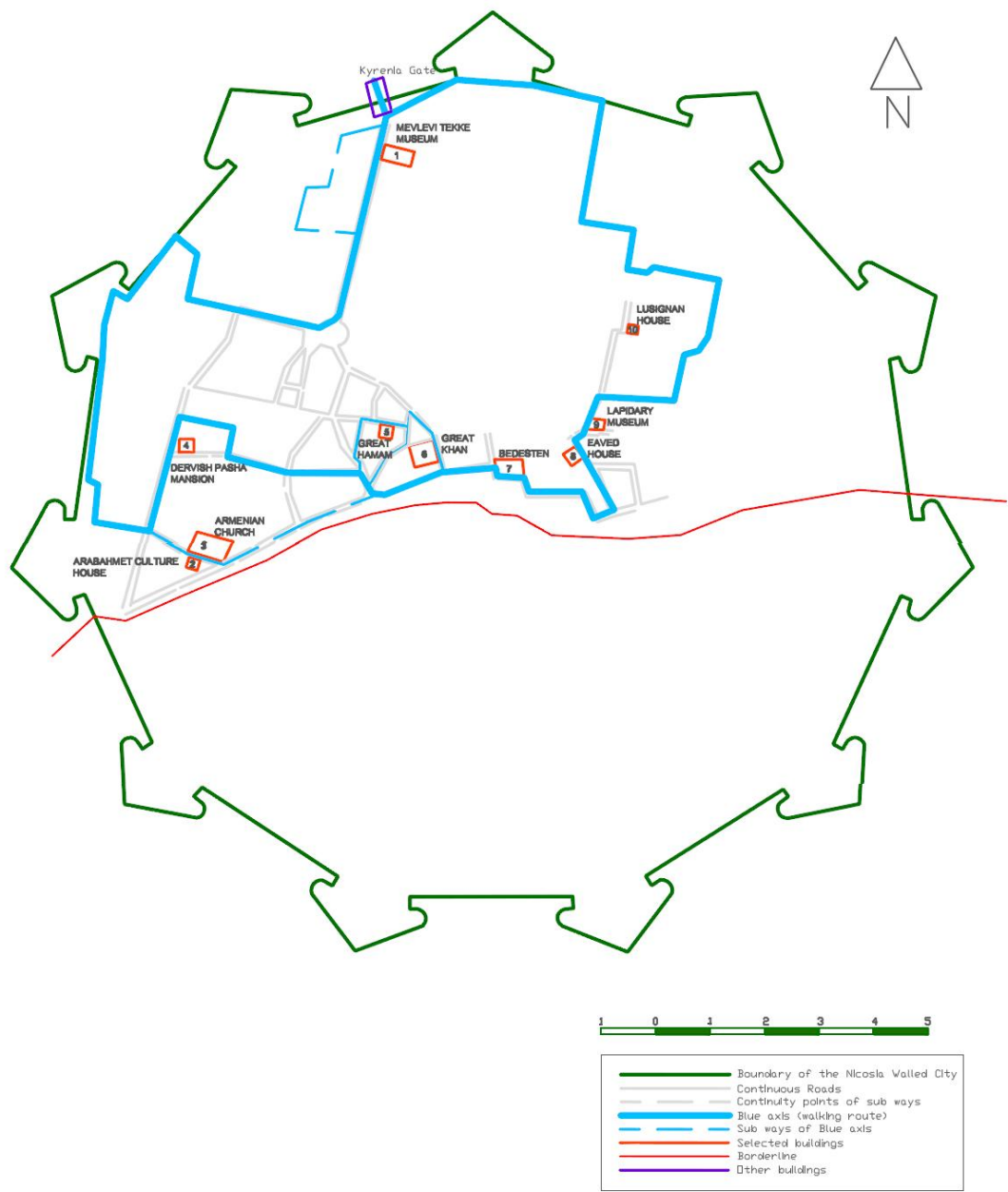

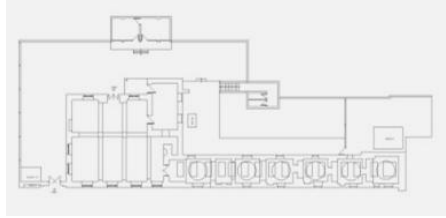





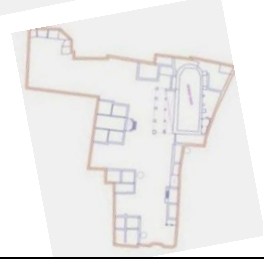





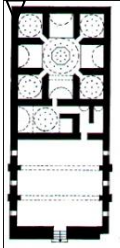

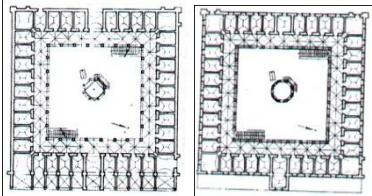
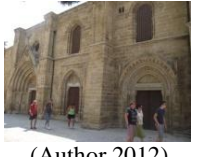
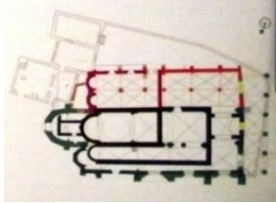

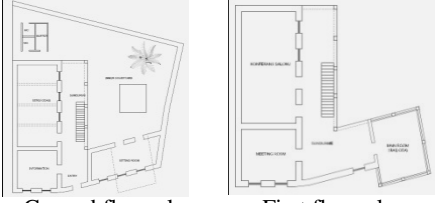

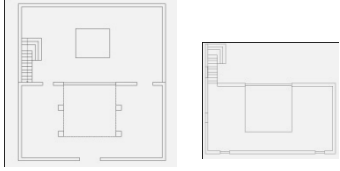

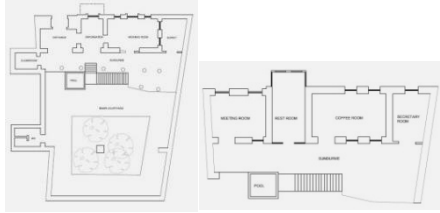

Figure 46: Locations of case buildings.

Table 8: General information on case - studies.

| | Old name / original function, previous function | New name / New function | Photograph | Drawings (Plan) |
|---|--|--------------------------|--|--|
| 1 | Mevlevi Tekke, Cyprus Turkish Ethnography Museum | Mevlevi Tekke Museum |  (Author,2012) | N   |
| | Tekke, Museum | Museum | | |
| | Location: Kyrenia Avenue | | | |
| 2 | - | Arabahmet Culture House |  (Author,2012) | N   |
| | Dwelling | Cultural activity centre | | |
| | Location: Arabahmet District | | | |
| 3 | Armenian Church | Armenian Church |  (Author,2011) |  N  |
| | Church | Culture Centre | | |
| | Location: Arabahmet District | | | |
| 4 | Dervish Pasha Mansion | Dervish Pasha Mansion |  (Author,2012) |  N  Ground floor plan First floor plan |
| | House | Museum | | |
| | Location: Arabahmet District | | | |
| 5 | Great Hamam | Great Hamam |  (Author,2012) | N   |
| | Baths | Baths/museum | | |
| | Location: Irfan Bey Street | | | |

| | | | | |
|----|------------------------|---|--|---|
| 6 | Great Khan | Great Khan |  (Author,2012) | N▷  Ground floor plan First floor plan |
| | Inn | Inn | | |
| 7 | Bedesten | Bedesten |  (Author,2012) | N▽  |
| | Church Market place | Museum, cultural social activity centre | | |
| 8 | The Eaved House | The Eaved House |  (Author,2012) | N▷  Ground floor plan First floor plan |
| | House | Culture and art centre | | |
| 9 | | Lapidary Museum |  (Author,2012) | Δ N  Ground floor plan Mezzanine floor plan |
| | Guest house | Museum | | |
| 10 | Lusignan House | Lusignan House |  (Author,2012) | N◁  Ground floor plan First floor plan |
| | House | Museum | | |

Case buildings' analyses are conducted to understand accessibility conditions of these buildings' circulations. When case buildings were being analysed, their spaces are categorized according to their locations and organizations. Their names are given according to their openness or being closed, also locations. Organization about the categories of spaces, are ordered from outside to inside of the building. According to this system categorization of spaces are examined as below;

- 1)**Outdoor spaces** start at the street and ends on the entrance of the building or site.
- 2)**Semi-open spaces** generally link different spaces to each other. For instance, they may link indoor spaces to defined-open spaces.
- 3)**Indoor spaces** are closed spaces of the building, in other words they are main parts of the buildings.
- 4)**Defined open spaces** are courtyards or backyards of the buildings, and they cover both horizontal and vertical circulation. Also, they may cover some closed space functions like restrooms.

All selected buildings have analyzed according to specified principles within accessibility standards and precision of circulations. Relation of spaces in historic public buildings, which are case studies, examined according to circulation of visitors and it changes according to space organizations of buildings. Transitional relations between semi-open spaces, indoor spaces, and defined open spaces, shows differences in selected buildings.

Circulation spaces are defined and circulation components and their standards are mentioned in terms of horizontal and vertical circulation in chapter 3. In this study, circulation paths are examined according to defined categorization of spaces in

selected historic public buildings. As it is mentioned in analysing chart (Table 6), circulation of building is analysed as horizontally and vertically.

Table 6 includes more detailed observation factors that are related with circulation components of **outdoor spaces**, **semi open spaces**, **indoor spaces**, and **defined open spaces**. To show results of analysis, this chart is used for each building. In these charts, accessibility conditions of buildings can be seen as a summary. Charts involve some short symbols;

- None existed circulation elements are shown as (-),
- Accessible circulation elements are shown as (A),
- Inaccessible circulation elements are shown as (I).
- Both accessible and inaccessible elements shown as (A/I).

4.1 Analysis of Mevlevi Tekke Museum According to Accessibility Standards

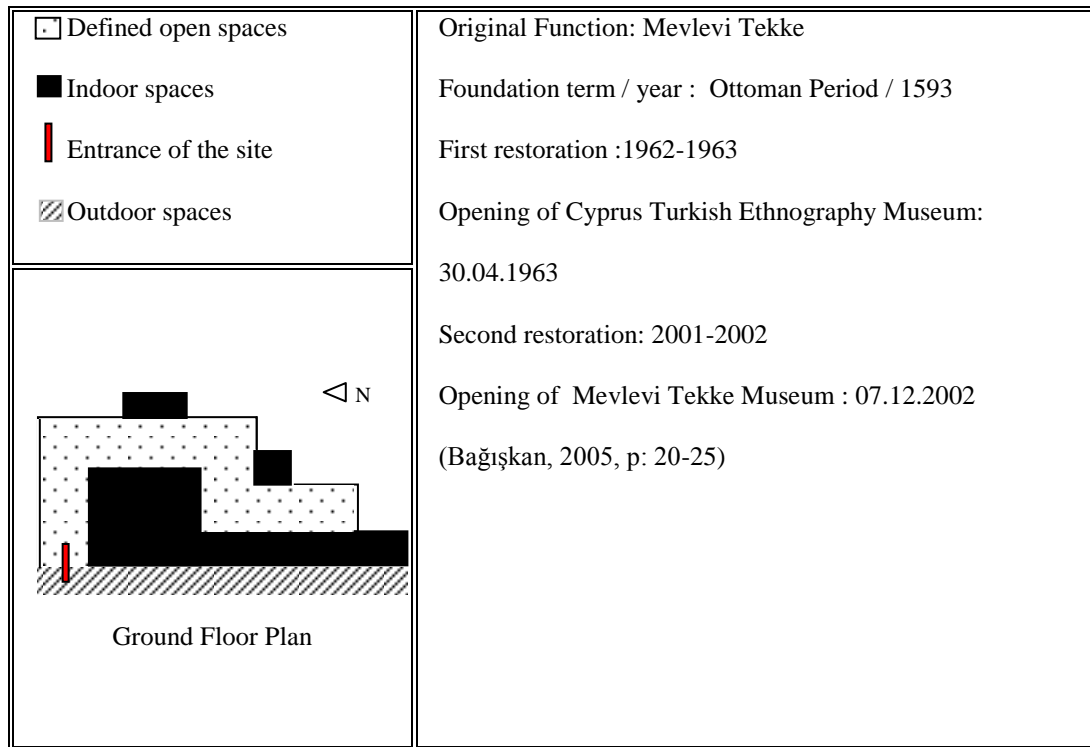

Figure 47: Information about Mevlevi Tekke Museum.

4.1.1 Analysis of Circulation Paths of Outdoor Spaces in relation with the Entrances

Circulation paths of outdoor spaces related with entrances consist of spaces, which start from the street and finish on the entrances of selected buildings. These spaces are categorized as parking spaces, pavements, outdoor ramps and stairs, and entrances.

Mevlevi Tekke Museum has a short period parking space that locates in front of the building, and two cars can park that space. There are no outdoor ramps and stairs related with the museum. There is one entrance to the courtyard (defined open space) from the front (West) side of the building. Also, there is one entrance to the main museum building which is in relation with courtyard.

a. Parking Spaces

Mevlevi Tekke museum does not have any regular parking space. However, there is a place that is in front of the museum and it which is used for short period parking.



Figure 48: Parking space (North East), Mevlevi Tekke Museum (Author, 2012).

- Parking space has enough distance with the entrance of the site.
- Its relation with pavement is in appropriate standards.

As a result, people may park their vehicles to that space, and they can visit the museum. These parking spaces are helpful to provide accessibility to the building.

b. Pavements

The only facade is front facade that faces to the street, so there is only one pavement which has relation with the building. Because of the density of the street, this pavement is used by multiple people.



Figure 49: Pavement, Mevlevi Tekke Museum (Author, 2012).

- The level difference is not more than 15 cm between street and pavement as well as between building and pavement.

Pavement is accessible from both building and street.

c. Outdoor Ramps and Stairs

There are no outdoor ramps and stairs around the Mevlevi Tekke Museum.

d. Entrances

There is one entrance to the main museum building which is open to the defined-open space of the building.

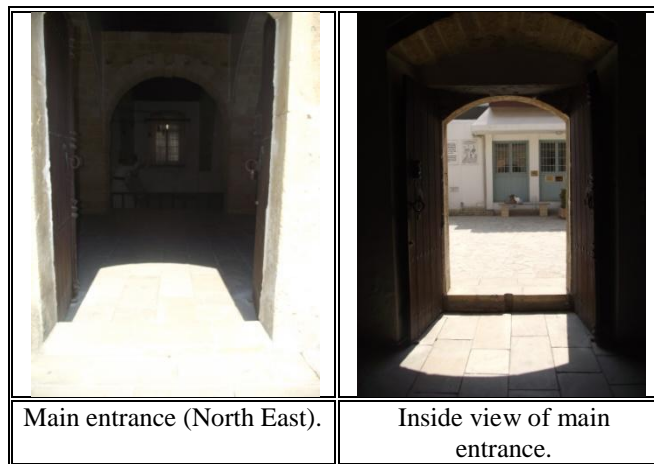

Figure 50: Entrances, Mevlevi Tekke Museum (Author, 2012).

- Entrance door is not accessible, as there is a step which has more than 6 cm height after the door. It is needed a ramp with this step but there is no ramp.

That step is a barrier for people who have physical disabilities. It hinders the usability of building by everyone.

4.1.2 Analysis of Circulation Paths of Semi-Open Spaces

Mevlevi Tekke Museum does not have any semi-open spaces.

4.1.3 Analysis of Circulation Paths of Indoor Spaces

Circulation paths of indoor spaces consist of closed spaces of selected buildings.

These spaces are analysed in terms of horizontal and vertical circulation elements.

Mevlevi Tekke Museum has three kind of separate indoor spaces. One of them is the main museum building. The other is information and staff service facilities, and the third one is restroom facilities. The focus of the research is on the museum and restroom functions.

4.1.3.1 Analysis of Horizontal Circulation

a. Entrance Halls

The building does not have any defined entrance hall.

b. Corridors

After the entrance part, the building has a linear organization that consists of narrow corridors and figurative tombs.

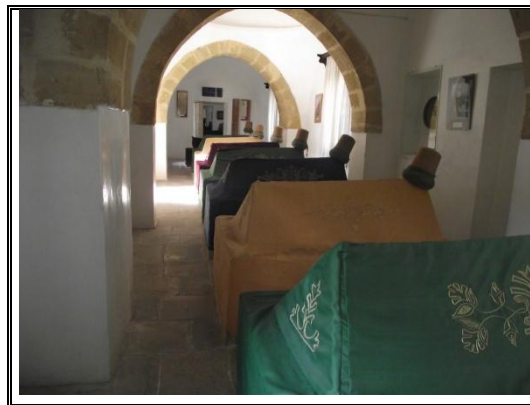

Figure 51: Indoor corridors, Mevlevi Tekke Museum (Author, 2012).

- There is not enough space to move among the figurative tombs.
- Widths of the corridors are between 600mm-700mm and it is not suitable for the activities that are done in the building.

Corridors are not accessible for circulation.

c. Internal doors and Passageways

There are various internal doorways without any door. Passageways generally consist of arches.



Figure 52: Passageways and doorways of indoor spaces, Mevlevi Tekke Museum (Author, 2011).

- Passageways have appropriate widths which are more than 815mm.
- Doorways' widths are not suitable for everyone, they are narrow than 815mm.
- Doors have level differences on both sides of them, in general.
- These level differences are solved with using steps without ramps.

Although passageways have suitable widths, steps block movements of people.

Doorways and steps hinder the continuity of the circulation in the indoor spaces.

4.1.3.2 Analysis of Vertical circulation

a. Steps and Stairs

There are no stairs in the building. Steps are located on the passageways and doorways in the building.

b. Ramps

There is no ramp existing in the building.

c. Lifts

There is not any lift existed in the building.

4.1.4 Analysis of Circulation Paths of Defined Open Spaces

Defined open spaces of selected buildings are courtyards or backyards of the buildings that are defined within the border of site. The circulation of defined open space of the buildings are analysed in terms of horizontal and vertical circulation elements of these spaces.

Mevlevi Tekke Museum has a courtyard as defined open space. Main circulation paths of the building have relation with courtyard circulation paths.

4.1.4.1 Analysis of Horizontal Circulation

a. Doors and Passageways

There is one door in the courtyard of the building, and it connects the outdoor spaces and courtyard.



Figure 53: Doors and passageways in the defined open spaces, Mevlevi Tekke Museum (Author,2012).

- The doorway has accessible clearance which is more than 815mm.

It is possible to use the door from both inside and outside. In other words, it gives access to both street and courtyard.

a. Pathways

Circulation paths of the courtyard are formed with open pathways that develop walking paths in the courtyard.

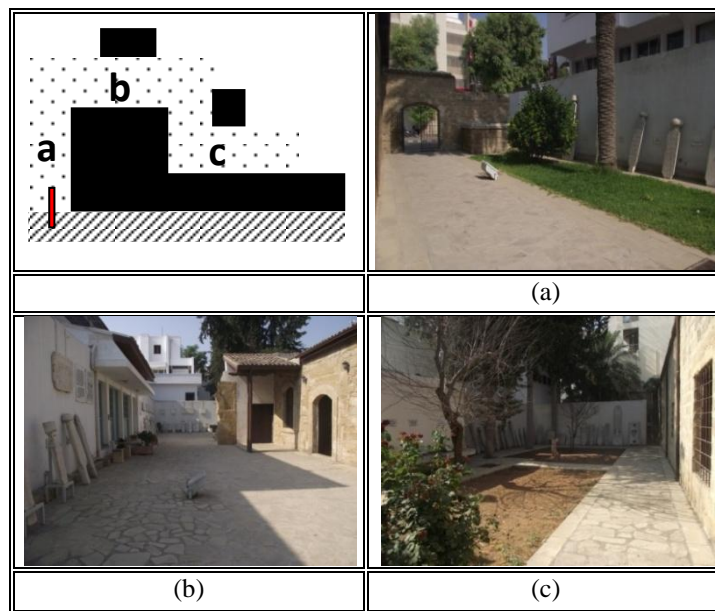

Figure 54: Pathways in the defined open spaces, Mevlevi Tekke Museum (Author, 2012).

- Pathways have more than 915mm widths for circulation in the courtyard.
- Between (a) and (b) there is a continuity without level differences but between (b) and (c) there is a level difference.
- Courtyard (c) level is 40 cm higher than the other parts.

Until (c) courtyard, it is possible to move around and visit the exhibition. However, because of the level difference between (b) and (c), although there is a ramp, (c) part of the courtyard is not accessible.

4.1.4.2 Analysis of Vertical circulation

a. Steps and Stairs

There are two stairs that are related with defined open space of the building.

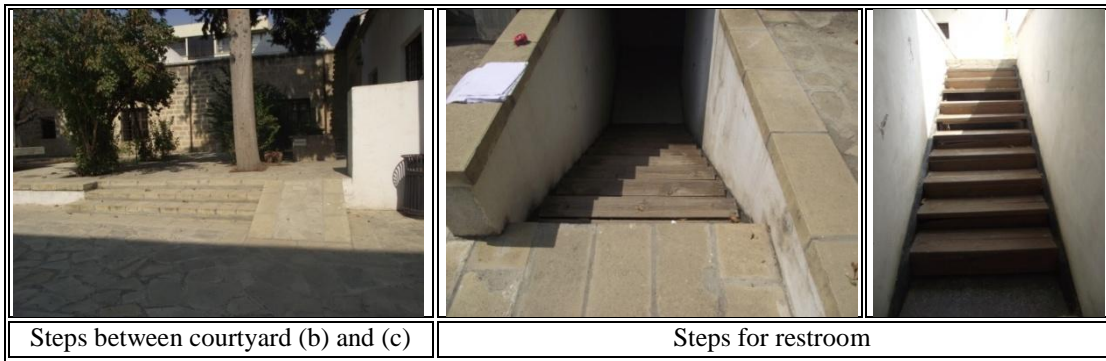

Figure 55: Steps and stairs in the defined open spaces, Mevlevi Tekke Museum (Author, 2012).

- One of them have ramp at the same circulation route, but the ramp does not provide accessibility for this route.

None of them have not suitable measurements, and they are not accessible.

b. Ramps

There is one ramp within the site of the building, and it is located in the courtyard of the building.



Figure 56: Ramp in the defined open spaces, Mevlevi Tekke Museum (Author, 2012).

- Its slope, length,height, and width do not have accessible measurements (slope: 16°, length: 1425mm, height: 400mm, width: 800mm). Also, it does not have handrails.

In other words, for physically disabled people, it is not possible to use the ramp.

c. Lifts

Mevlevi Tekke Museum does not have any lifts within existed condition. The building is one storey building, so, it is not necessary to adapt any kind of lift.

However, there are stairs as level difference within the building site. One of them have ramp next to itself, but one of them don't have. It is possible to adapt lift according to analysed standards.

Table 9: Analysis of Mevlevi Tekke Museum

| 1 | | Mevlevi Tekke Museum | | Space Organization of the Building | | Photos of the Building | | | | | |
|-------------------------------------|---|---|-----------------------|---|-----------------------|--|-----------------------|------------------------------------|--|--|--|
| | | | | KEY OF ORGANIZATION <ul style="list-style-type: none"> Outdoor spaces Semi-open spaces Indoor spaces Defined open spaces Parking spaces Pavements Entrances Lifts Steps and stairs Ramps Entrance halls Doors and passageways Corridors/ pathways | | | | | | | |
| | | | | | | Outdoor space. | | Defined open space. | | | |
| | | | | | | | | | | | |
| | | | | Steps in indoor space. | | Ceremony hall in indoor space. | | Exhibition corner in indoor space. | | | |
| Photos: Author, 2012. | | | | | | | | | | | |
| Circulation paths of outdoor spaces | | Circulation paths of semi-open spaces (The building does not have semi-open spaces.) | | Circulation paths of indoor spaces | | Circulation paths of defined open spaces | | General condition and suggestions | | | |
| | | | | | | | | | | | |
| Parking Spaces | A | Horizontal circulation paths | Entrance halls | - | Entrance halls | - | Doors and passageways | A | <p>This building have accessibility problems especially on the vertical circulation.</p> <p>The steps on the entrance create barriers for people.</p> <p>The staircase on the entrance of the restroom is a barrier for people. It is expected to adapt a stair lift on these staircase.</p> | | |
| | | | Doors and passageways | - | Doors and passageways | I | | | | | |
| Pavements | A | Vertical circulation paths | Corridors | - | Corridors | I | Pathways | A | | | |
| Outdoor ramps and stairs | - | | Steps and stairs | - | Steps and stairs | I | Steps and stairs | I | | | |
| | | | Ramps | - | Ramps | - | Ramps | I | | | |
| Entrances | A | Lifts | - | Lifts | - | Lifts | - | | | | |

4.2 Analysis of Arabahmet Culture House According to Accessibility Standards

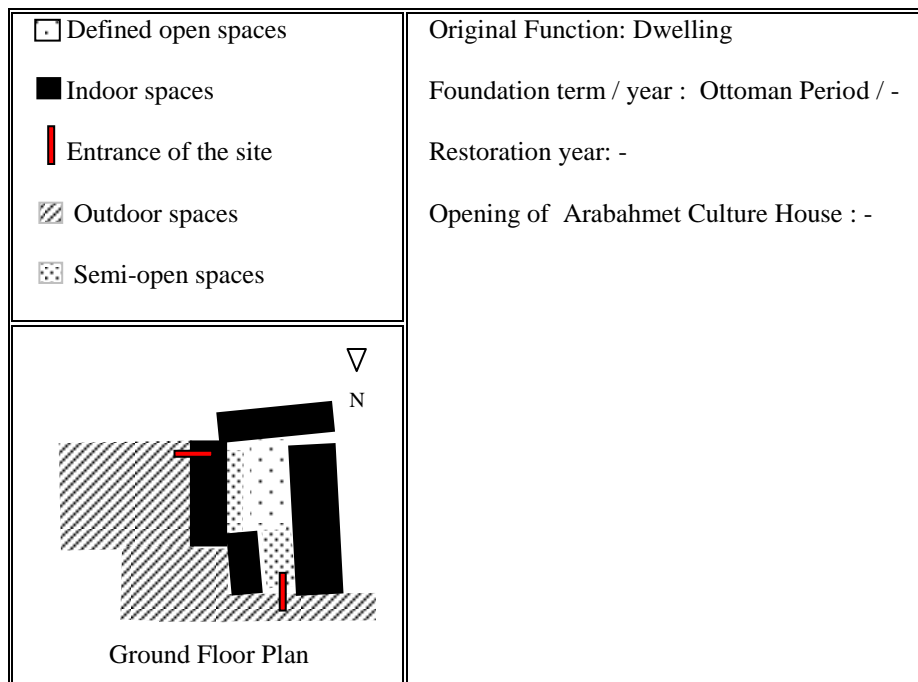

Figure 57: Information about Arabahmet Culture House.

4.2.1 Analysis of Circulation Paths of Outdoor Spaces in relation with the Entrances

Arabahmet Culture House has a parking space that locates at the back of the building. There are no outdoor ramps and stairs related with the building. There are two entrances to the courtyard (defined open space). One of them is from the front (North) side of the building; the other is next to the car park. Also, there is one entrance which is next to the main (North) entrance and it is not in permanent usage; it used as alternative exit when there is an activity happen.

a. Parking Spaces

There is a parking space at the right side of the building which belongs to the building site. The car park is in a good relationship with the both of the building entrances.



Figure 58: Parking space (North East), Arabahmet Culture House (Author,2012).

- Parking space has enough distance with entrances of the site.
- Its relation with pavement is in appropriate standards.

As a result, people may park their vehicles to that space, and they can visit the building. The parking space is useful to provide accessibility to the building.

b. Pavements

North and East facade of the building face to the path. Building has relation with both pavements which located at the front and the right side of the building.



Figure 59: Pavement, Arabahmet Culture House (Author, 2012).

- There are no level differences between street and pavement and between building and pavement.

Pavement is accessible from both building and street.

c. Outdoor Ramps and Stairs

There are no outdoor ramps and stairs around the Arabahmet Culture House.

d. Entrances

There is a main entrance to the building site which is open to the semi-open space of the building. Also, there is back entrance which is on the East.



Figure 60: Entrances, Arabahmet Culture House (Author, 2012).

- Entrance door is not accessible, because there is a step which has more than 6 cm height before the door opening.
- There are two steps after entering inside.

These steps are barriers for people who have physical disabilities. They hinder the usability of building by everyone.

4.2.2 Analysis of Circulation Paths of Semi Open Spaces

Arabahmet Culture House has two kind of semi-open spaces. The first one starts at the entrance of the building and ends with the beginning of the courtyard. This space involves waiting area and one entrances of the activity hall and information room are in that space. The other semi-open space is in relation with the other activities of the building, so this study does not consider that space.

4.2.2.1 Analysis of Horizontal Circulation

a. Entrance Halls

The entrance of the building open to this space, but there is no defined entrance hall. The entrance hall is used as a corridor. However, it is accessible, because there are no level differences in this hall.

b. Corridors

Semi open spaces are consisted of corridors. These corridors connect indoor spaces and open defined space.



Figure 61: Corridors in semi open spaces, Arabahmet Culture House (Author, 2012).

- Corridor is accessible in itself, because there is no level difference.
- It is difficult to reach to the corridor, because there is a step before the corridor.

c. Internal doors and Passageways

Two internal doors open to the semi open space of the building. One of them belongs to information room; the other belongs to the activity hall. Also, there are two arches that form the passageways.

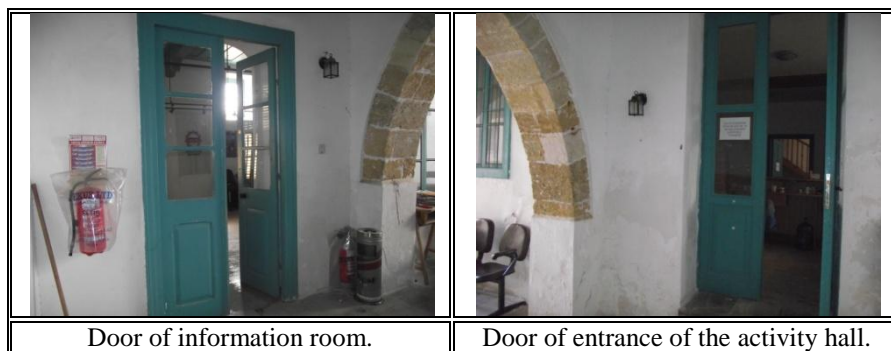

Figure 62: Doors in semi-open space, Arabahmet Culture House (Author, 2012).

- Doors have accessible widths when their two leafs are open.

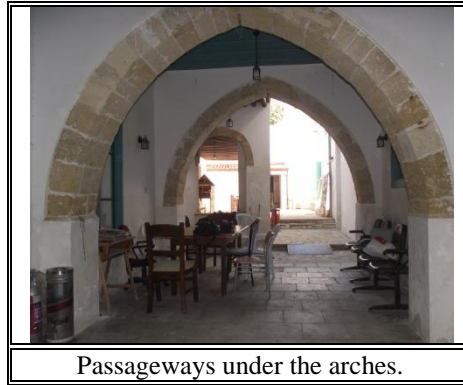

Figure 63: Passageways in semi-open space, Arabahmet Culture House (Author, 2012).

- Passageways have suitable measurements as more than 915mm for circulation in that space.

Both doors and passageways provide accessible circulation in the semi open space of the building.

4.2.2.2 Analysis of Vertical circulation

a. Steps and Stairs

Except the first step on the entrance, there are no steps and stairs existing at the semi open space.

b. Ramps

There are no ramps existing in the semi open space of the building.

c. Lifts

There are no lifts existing in the building.

4.2.3 Analysis of Circulation Paths of Indoor Spaces

The building has indoor spaces on ground floor and first floor. The first floor of the building is not in use. The consideration of the research is activity spaces on the ground floor. One of these spaces is the main activity building. The other is information and staff service facilities, and the third one is restroom facility.

4.2.3.1 Analysis of Horizontal Circulation

a. Entrance Halls

There is no entrance hall.

b. Corridors

In the activity hall, there are corridors between sitting groups and within sitting elements and the wall.



Figure 64: Indoor corridors, Arabahmet Culture House (Author, 2012).

- Width of corridor between sitting groups is suitable for circulation.
- There is not enough space to move between the wall and sitting elements.

Only the corridor between sitting groups is accessible, the other corridors are not accessible for circulation.

c. Internal doors and Passageways

There is a passageway within the activity hall that serves for visitors. The other doors belong to back stage or stage and they are not considered in this study.



Figure 65: Passageway, Arabahmet Culture House (Author, 2011).

- Passageway has appropriate widths that are more than 815mm.

- However, there are two steps after passageway and they block people's movement.

Although passageways have suitable widths, steps block movements of people.

4.2.3.2 Analysis of Vertical circulation

a. Steps and Stairs

The only stair in the activity parts of the building is the stage stair. Also, there are steps that locate on the passageways and doorways in the building.

b. Ramps

There is no ramp existing in the building.

c. Lifts

There is no lift existing in the building.

4.2.4 Analysis of Circulation Paths of Defined Open Spaces

Arabahmet Culture House has a courtyard as defined open space. All circulation paths of the building have relation with circulation paths of the courtyard.

4.2.4.1 Analysis of Horizontal Circulation

a. Doors and Passageways

There is two doors that open to the courtyard. Both of them belong to the activity hall.

There are no passageways.



Figure 66: Doors in the defined open spaces, Arabahmet Culture House (Author, 2012).

- Doors have accessible measurements about their widths and heights.
- One of them is not accessible, because of the steps on the courtyard side of the door.

It is possible to use the exit door from both inside and outside. However, the other door does not have accessible circulation measurements.

b. Pathways

Circulation paths of the courtyard form with pathways that create walking paths in the courtyard.



Figure 67: Pathway in the defined open space, Arabahmet Culture House (Author, 2012).

- Pathway has enough widths for circulation in the courtyard.
- There are level differences on the pathway.

Because of the stair on the pathway, the circulation is not accessible.

4.2.4.2 Analysis of Vertical circulation

a. Steps and Stairs

There are two steps that are on the corridor of the defined open space in the building.



Figure 68: Steps in the defined open spaces, Arabahmet Culture House (Author, 2012).

- One of them has a ramp at the same circulation route.

None of the steps has not suitable measurements, so they are not accessible.

b. Ramps

There is one ramp within the site of the building, and it is located in the courtyard of the building.



Figure 69: Ramp in the defined open spaces, Arabahmet Culture House (Author, 2012).

- The ramp has accessible measurements for accessible using.

In other words, for physically disabled people, it is possible to use the ramp, and reach the entrance (exit) of the hall.

c. Lifts

Arabahmet Culture House does not have any lifts within the existing condition. The building is one storey building, so, it is not necessary to adapt any kind of lift.

4.3 Analysis of Armenian Church According to Accessibility

Standards

The site of the Armenian Church is closed during the analysing period. Many applications and requests are being left unanswered by responsible institutes and people. As a result, the site and building of the Armenian Church could not analysis.

Table 10: Analysis of Arabahmet Culture House

| 2 Arabahmet Culture House | | Space Organization of the Building | | Photos of the Building | | | | | |
|---|---|------------------------------------|-----------------------|--|----------------------------------|--|-----------------------|---|--|
| | | KEY OF ORGANIZATION | | | | | | | |
| | | | | Outdoor space (Pavement in front of the building). | Semi open space (Entrance hall). | Indoor space (Information room). | | | |
| | | | | | | | | | |
| | | | | Indoor space (Activity hall). | Defined open space. | Defined open space (Ramp and steps). | | | |
| | | | | Photos: Author,2012. | | | | | |
| | | | | Circulation paths of outdoor spaces | | Circulation paths of semi-open spaces | | Circulation paths of indoor spaces | |
| | | | | | | | | | |
| Parking Spaces | A | Horizontal circulation paths | Entrance halls | A | Entrance halls | - | Doors and passageways | I | |
| Pavements | A | | Doors and passageways | A | Doors and passageways | I | | | |
| Outdoor ramps and stairs | - | | Corridors | I | Corridors | I | Pathways | I | |
| Entrances | I | Vertical circulation paths | Steps and stairs | I | Steps and stairs | I | Steps and stairs | I | |
| | | | Ramps | - | Ramps | - | Ramps | I | |
| | | | Lifts | - | Lifts | - | Lifts | - | |
| <p>This building have significant accessibility problems. The steps on the entrance create barriers for people. Corridors do not have accessible width, it is lower than 915mm.</p> | | | | | | | | | |

4.4 Analysis of Dervish Pasha Mansion According to Accessibility Standards

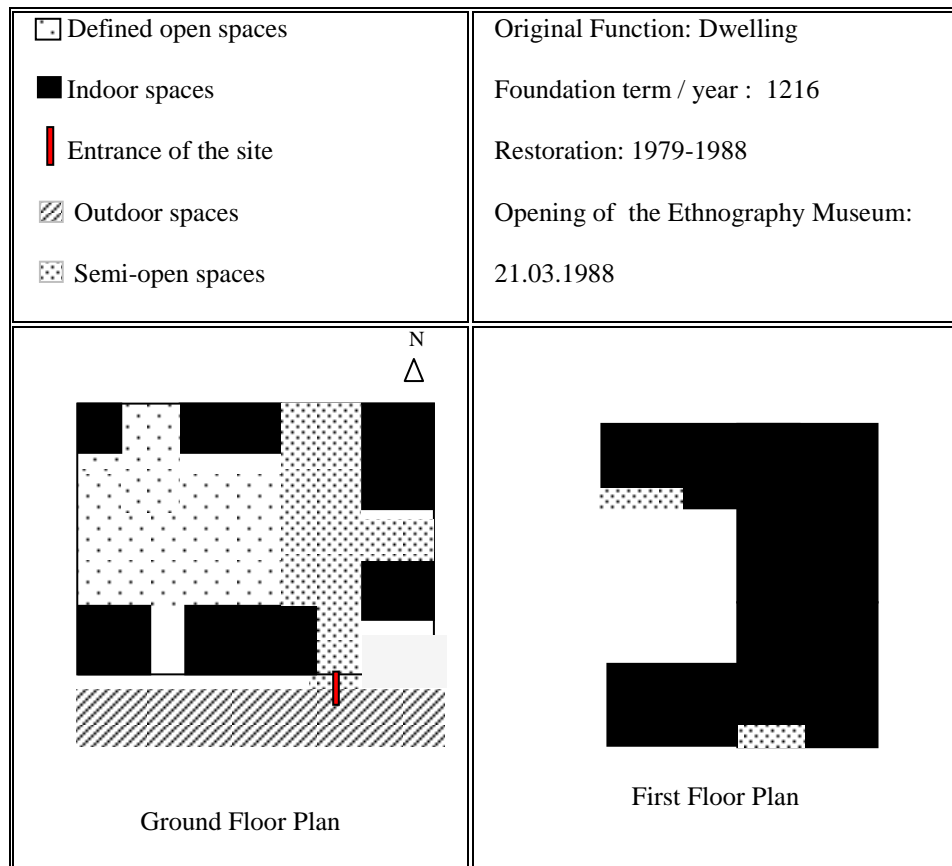

Figure 70: Information about Dervish Pasha Mansion.

4.4.1 Analysis of Circulation Paths of Outdoor Spaces in relation with the Entrances

Dervish Pasha Mansion does not have outdoor spaces related with the entrance. The building has one entrance that is on the South side of the building.

a. Parking Spaces

Dervish Pasha Mansion does not have a parking space, but in front of the building there is a car parking area. The parking area has strong relationship with the entrance of the mansion. It is possible to park the car to this parking space and reach the entrance of the building.

b. Pavements

There is no pavement around the building.

c. Outdoor Ramps and Stairs

There are no outdoor ramps and stairs around the Mansion.

d. Entrances

Dervish Pasha Mansion has one entrance; the entrance is on the South.



Figure 71: Entrances, Dervish Pasha Mansion (Author, 2012).

- Width of the door is suitable.
- There are steps which block the access for the building.

As a result, entrance is not accessible because of these steps.

4.4.2 Analysis of Circulation Paths of Semi-Open Spaces

Semi-open spaces of the mansion start at the entrance. These spaces are corridors among spaces; indoor and courtyard spaces.

4.4.2.1 Analysis of Horizontal Circulation

a. Entrance Halls

There is an entrance hall after entrance, but its design does not give information about functions of building, as a result, it cannot orientate people. There is a ticket point on the entrance hall.



Figure 72: Entrance hall, Dervish Pasha Mansion (Author, 2012).

b. Corridors

All semi-open spaces consist of corridors on both floors of the building. The corridors (Sündürme) on the ground floor has continuity as 'L' shape, as same as the building shape.

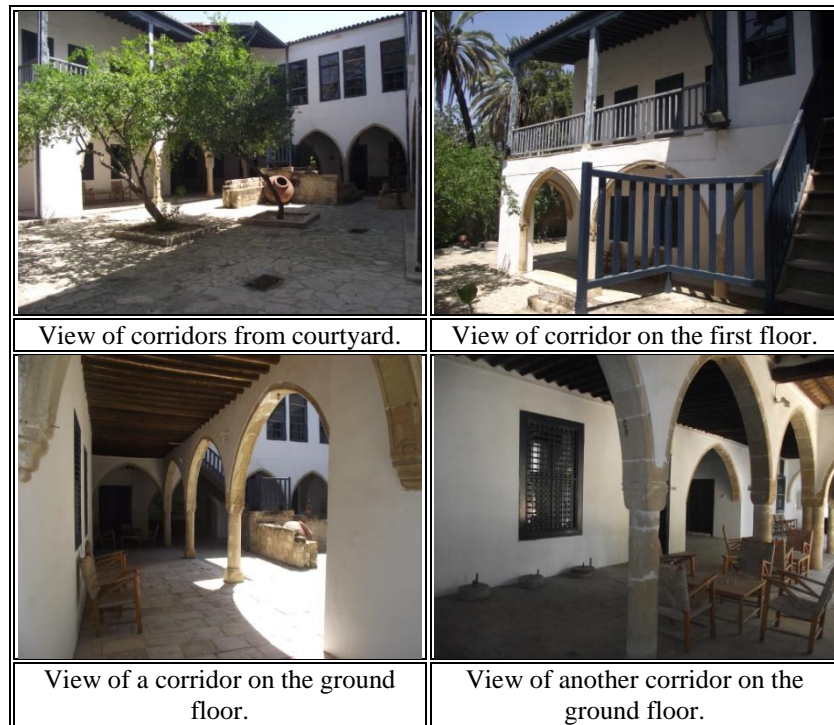

Figure 73: Corridors at the semi-open spaces, Dervish Pasha Mansion (Author, 2012).

- Circulation at the corridors is possible, in general.
- Widths of corridors are usable by everyone.
- These corridors use for sitting and displaying areas.

There is a proper circulation in the corridors of the building. The circulation is accessible in semi open spaces of the building.

c. Internal doors and Passageways

Doors of rooms open to the semi open spaces on the ground floor. Also, on the first floor, doors open to the common corridor which has same organization with Sündürme that on the ground floor.



Figure 74: Doors at the semi-open spaces, Dervish Pasha Mansion (Author, 2012).

- Doors have widths between 115-145 cm.
- There are level differences between corridor and the dining room.

Usually, rooms are accessible in the building. Door widths are accessible, but there is a step before entrance of the dining room, and it blocks the circulation on that space.

4.4.2.2 Analysis of Vertical circulation

a. Steps and Stairs

There is a step in the semi open space that is within the door of the dining room.



Figure 75: Step in the semi-open space, Dervish Pasha Mansion (Author, 2012).

b. Ramps

There is no ramp existing in this space.

c. Lifts

There is no lift existing in this space.

4.4.3 Analysis of Circulation Paths of Indoor Spaces

4.4.3.1 Analysis of Horizontal Circulation

a. Entrance Halls

Indoor spaces do not have defined entrance halls.

b. Corridors

There are corridors on the first floor of the building.



Figure 76: Corridors in the indoor spaces, Dervish Pasha Mansion (Author, 2012).

- Widths are suitable for circulation.
- There are not any level differences existed.
- At the end of the corridor, there is a stair that connects the corridor to the hall of the main room.

Corridors are accessible in the indoor spaces of the Mansion.

c. Internal doors and Passageways

Indoor spaces have internal doors and passageways on the first floor.



Figure 77: Doors at the indoor spaces, Dervish Pasha Mansion (Author, 2012).

- Doors have widths between 115cm and 145 cm.
- Before the entrance of the main room there is a stair on the first floor.

Usually, rooms are accessible in the building. Door widths are accessible, but there is a stair that hinders people's movement on that space.

4.4.3.2 Analysis of Vertical circulation

a. Steps and Stairs

There is a stair that is on the corridor before the main room.



Figure 78: Stair in the indoor space, Dervish Pasha Mansion (Author, 2012).

- The stair has four steps that covered the width of the corridor.
- There is not any ramp or lift existed for circulation.

Consequently, the stair blocks the continuity of the circulation on the first floor.

b. Ramps

There are not any ramps existed in the building.

c. Lifts

There are not any lifts existed in the building.

4.4.4 Analysis of Circulation Paths of Defined Open Spaces

4.4.4.1 Analysis of Horizontal Circulation

a. Doors and Passageways

In the defined open space, there are passageways, but there are no doors existing.

Passageways are connections among semi open spaces and courtyard.

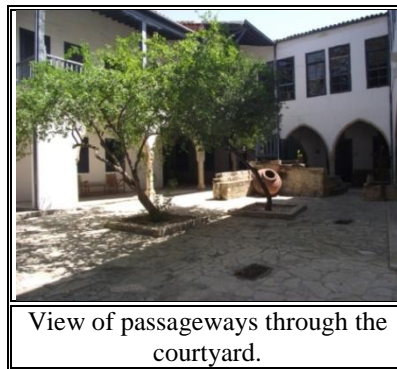

Figure 79: Passageways in the courtyard, Dervish Pasha Mansion (Author, 2012).

- Passageways generally consist of arches and columns.
- These passageways' widths are suitable for circulation.

Passageways provide accessible circulation between courtyard and Sündürme.

b. Pathways

There is no pathway in the defined open space.

4.4.4.2 Analysis of Vertical circulation

a. Steps and Stairs

There is one stair in the defined open space of the building.



Figure 80: Stair in the defined open space, Dervish Pasha Mansion (Author, 2012).

- Stair has 17 steps; risers: 19-24 cm treads: 30 cm, and handrails' height 90 cm.

The stair does not have accessible standard. Also, there are not any ramps or lifts existed next to the stairs. As a result, the stair is not accessible.

b. Ramps

There are no ramps existing in the building.











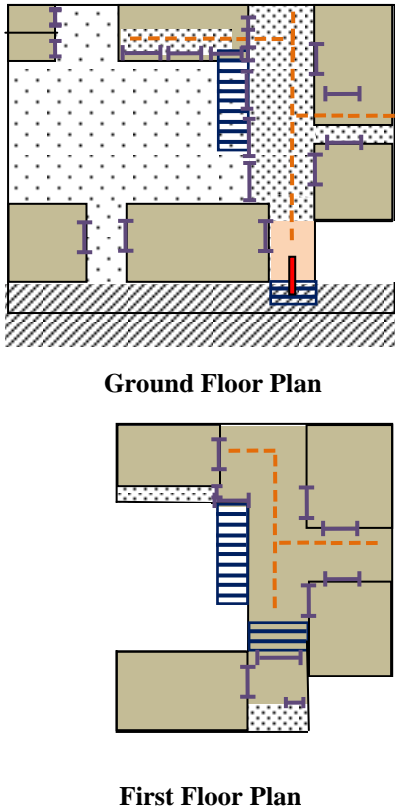









c. Lifts

Dervish Pasha Mansion does not have lifts within existing condition. The building is two storey building, so, it is necessary to adapt a kind of passenger lift. If it is not possible to adapt a passenger lift because of the building' historical value, platform lifts may be suitable. An external wheelchair platform lift, a stair wheelchair platform lift, ora chair stair lift can adapt to the stair.

4.5 Analysis of Great Hamam According to Accessibility Standards

The building of Great Hamam is closed during the analysing period. Many applications and requests are being left unanswered by responsible institutes and people. As a result, Great Hamam could not analyse.

Table 11: Analysis of Dervish Pasha Mansion

| 4 Dervish Pasha Mansion | | Space Organization of the Building | | Photos of the Building | | | | | |
|---|---|---|---|---|---|--|-----------------------|-----------------------------------|---|
|  <p>Ground Floor Plan</p> <p>First Floor Plan</p> | | <p>KEY OF ORGANIZATION</p> <ul style="list-style-type: none">  Outdoor spaces  Semi-open spaces  Indoor spaces  Defined open spaces  Parking spaces  Pavements  Entrances  Lifts  Steps and stairs  Ramps  Entrance halls  Doors and passageways  Corridors/ pathways | |  <p>Outdoor space.</p> |  <p>Semi open space.</p> |  <p>Defined open space.</p> | | | |
| | |  <p>Indoor space (Sitting room).</p> |  <p>Indoor space (Exhibition room).</p> |  <p>Defined open space (Stair).</p> | | | | | |
| Photos: Author, 2012. | | | | | | | | | |
| Circulation paths of outdoor spaces | | Circulation paths of semi-open spaces | | Circulation paths of indoor spaces | | Circulation paths of defined open spaces | | General condition and suggestions | |
| | | | | | | | | | |
| Parking Spaces | - | Horizontal circulation paths | Entrance halls | A | Entrance halls | - | Doors and passageways | | A |
| Pavements | - | | Doors and passageways | I | Doors and passageways | A | Pathways | | - |
| Outdoor ramps and stairs | I | | Corridors | A | Corridors | A | Steps and stairs | | I |
| Entrances | I | Vertical circulation paths | Steps and stairs | - | Steps and stairs | I | Ramps | - | |
| | | | Ramps | - | Ramps | - | Lifts | - | |
| | | | Lifts | - | Lifts | - | | | |

The building have problems on the vertical circulation.

The steps on the entrance create barriers for people.

The staircase that is in the defined open space is not accessible. It is expected to have a platform lift or chair lift.

4.6 Analysis of Great Khan According to Accessibility Standards

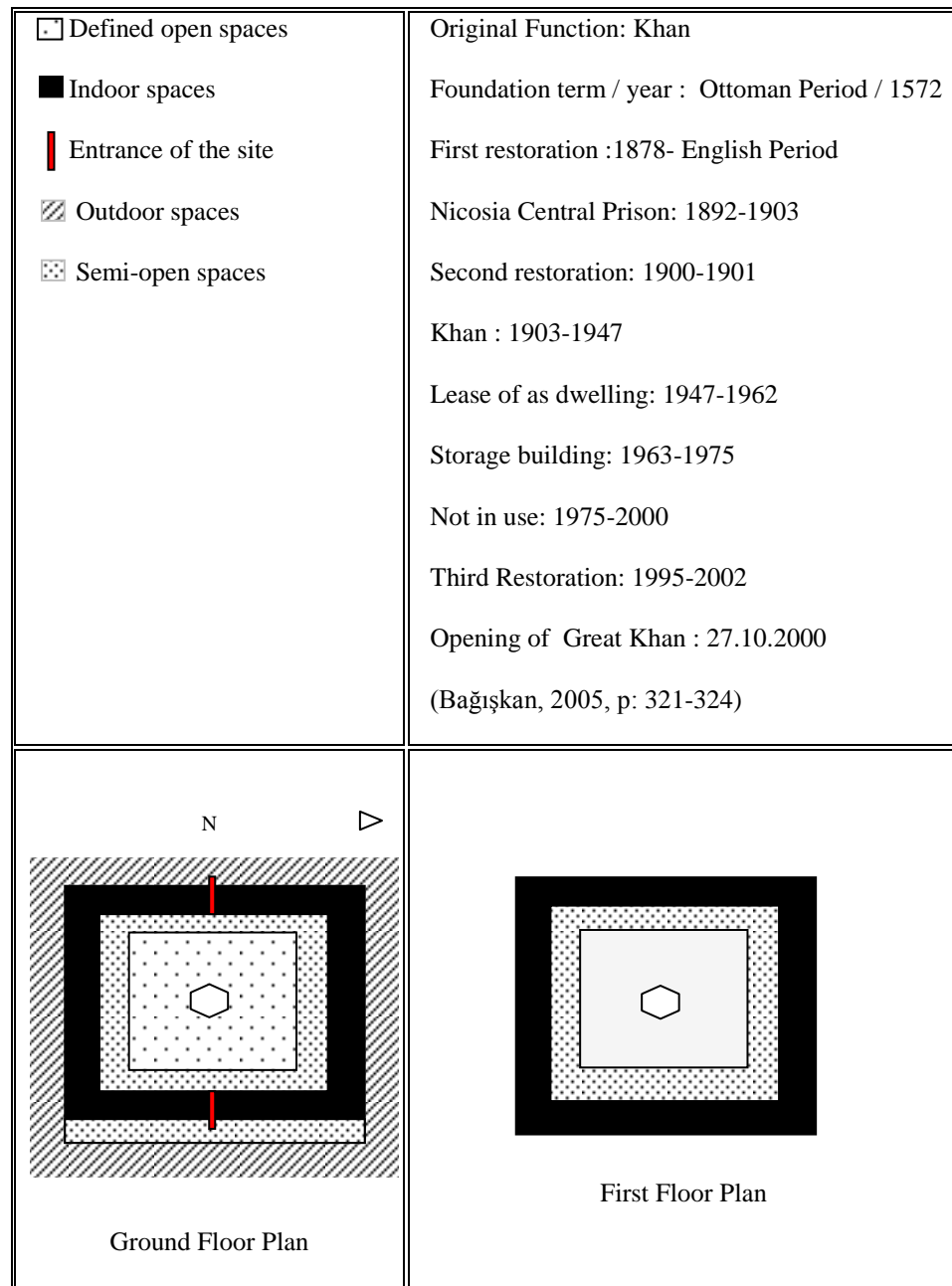

Figure 81: Information about Great Khan.

4.6.1 Analysis of Circulation Paths of Outdoor Spaces in relation with the Entrances

Great Khan does not have a parking space, and ramps and stairs that belong to its site.

There are two entrances of the building. The main entrance is on the East, and the other is on the West.

a. Parking Spaces

Great Khan does not have any space for parking. However, there is a parking area that locates on the North East of the building, and it has relation with the building by street. Also, people with disabilities may come to both entrances with their car or other vehicles.

b. Pavements

There is no pavement around the building. There is a semi open space which name as “Sündürme” in front of the building.

c. Outdoor Ramps and Stairs

There are no outdoor ramps and stairs around the Great Khan.

d. Entrances

Great Khan has two entrances; the main entrance is on the West, and the back entrance is on the East.

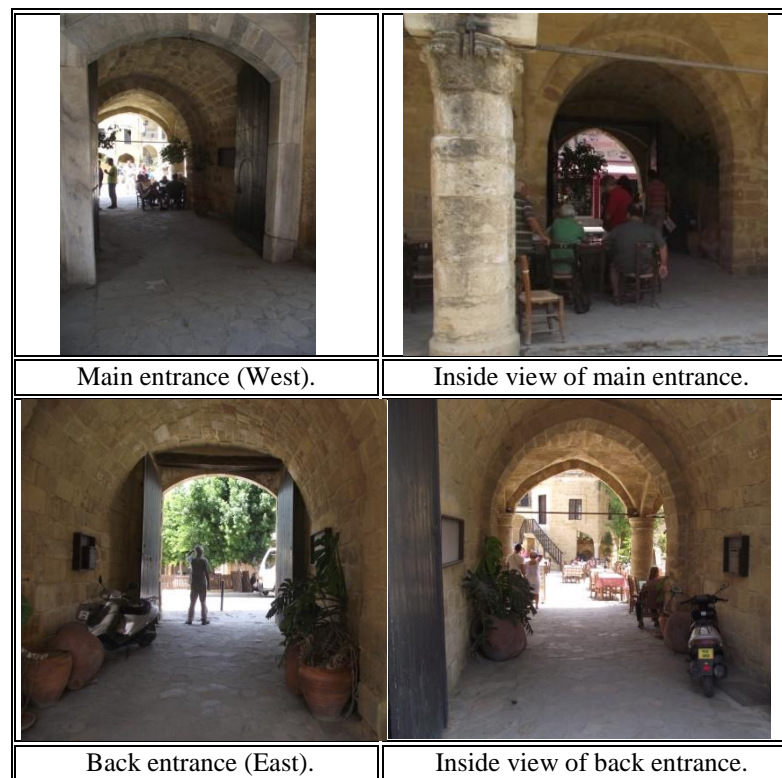

Figure 82: Entrances, Great Khan (Author, 2012).

- Widths of the passageways are suitable.

- There are slope surfaces which provide access for both indoor and courtyard by eliminating the level differences.

Both main entrance and back entrance are accessible.

4.6.2 Analysis of Circulation Paths of Semi Open Spaces

Great Khan has two kinds of semi open spaces. One of them is located in front of the building as "Sündürme". The other semi open spaces are corridors that connect the indoor spaces to each other on the first floor. Also, on the ground floor it connects indoor spaces and courtyard.

4.6.2.1 Analysis of Horizontal Circulation

a. Entrance Halls

There is an entrance hall after entrance, but its design does not give information about functions of building, as a result it cannot orientate people.



Figure 83: Entrance hall, Great Khan (Author, 2012).

b. Corridors

All semi-open spaces consist of corridors in both floors of the building.

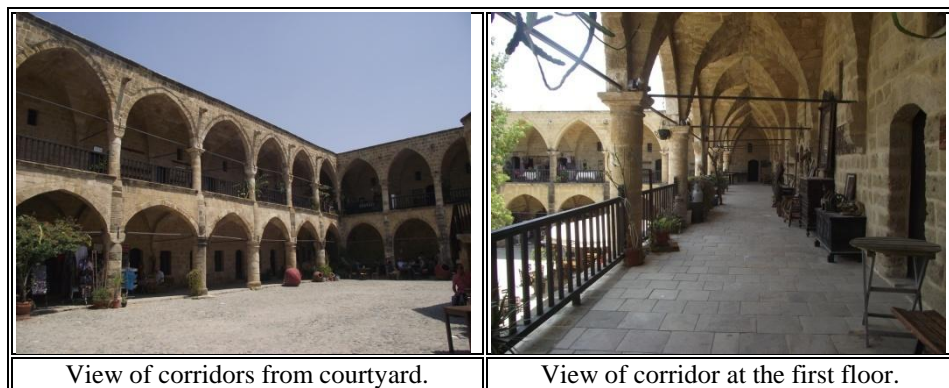

View of corridors from courtyard.

View of corridor at the first floor.

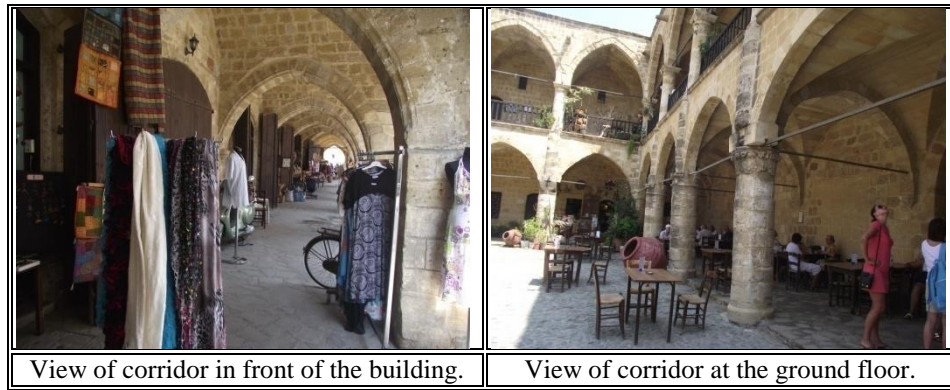

View of corridor in front of the building. View of corridor at the ground floor.

Figure 84: Corridors at the semi-open spaces, Great Khan (Author, 2012).

- Circulation at the corridors is possible, in general.
- Widths of corridors are usable by everyone.
- These corridors use for sitting and displaying areas.
- Sometimes staffs of some shops fill the circulation spaces, and block the movement of people.

There is not a proper circulation in the corridors of the building. Sometimes, the circulation is accessible, sometimes it blocks by staff of the shops.

c. Internal doors and Passageways

All shop doors open to the semi open spaces.

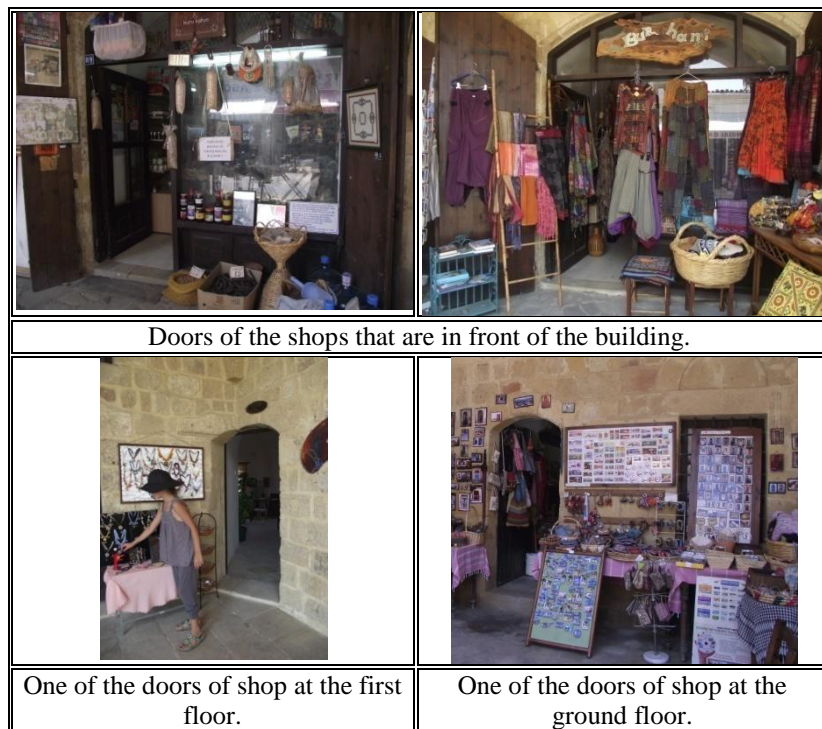

Doors of the shops that are in front of the building.

One of the doors of shop at the first floor.

One of the doors of shop at the ground floor.

Figure 85: Doors at the semi open spaces, Great Khan (Author, 2012).

- Doors have similar widths between 80cm and 85 cm.
- Door widths are not accessible.
- Some of the shops' interiors have level differences.
- The step height reach 17 cm in those shops, and it hinders people's movement.

As a result, usually shops are not accessible in the building.

4.6.2.2 Analysis of Vertical circulation

a. Steps and Stairs

There are no steps and stairs existing at the semi-open spaces.

b. Ramps

There are no ramps existing in this space.

c. Lifts

There are no lifts existing in this space.

4.6.3 Analysis of Circulation Paths of Indoor Spaces

4.6.3.1 Analysis of Horizontal Circulation

a. Entrance Halls

There is no entrance hall.

b. Corridors

There are no corridors.

c. Internal doors and Passageways

There are no internal doors and passageways.

4.6.3.2 Analysis of Vertical circulation

a. Steps and Stairs

There are no steps or stairs existing in the indoor spaces of the building.

b. Ramps

There are no ramps existing.

c. Lifts

There are no lifts existing.

4.6.4 Analysis of Circulation Paths of Defined Open Spaces

4.6.4.1 Analysis of Horizontal Circulation

a. Doors and Passageways

In the defined open space, there are passageways, but there are no doors existing.

Passageways are connections between semi open spaces and courtyard.

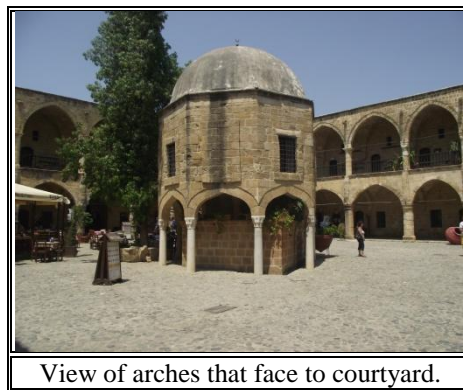

Figure 86: Passageways in the courtyard, Great Khan (Author, 2012).

- Passageways generally consist of arches and columns.
- These passageways' widths are suitable for circulation.

Passageways provide accessible circulation through themselves.

b. Pathways

There are no pathways existing in the defined open space.

4.6.4.2 Analysis of Vertical circulation

a. Steps and Stairs

There are two stairs in the defined open space of the building.



Figure 87: Steps and stairs in the defined open spaces, Great Khan (Author, 2012).

- Each stairs have same features; 25 steps, risers: 18 cm, treads: 31 cm, and handrails' height 85 cm.

They are not accessible, because there is no ramp or lift existing next to the stairs.











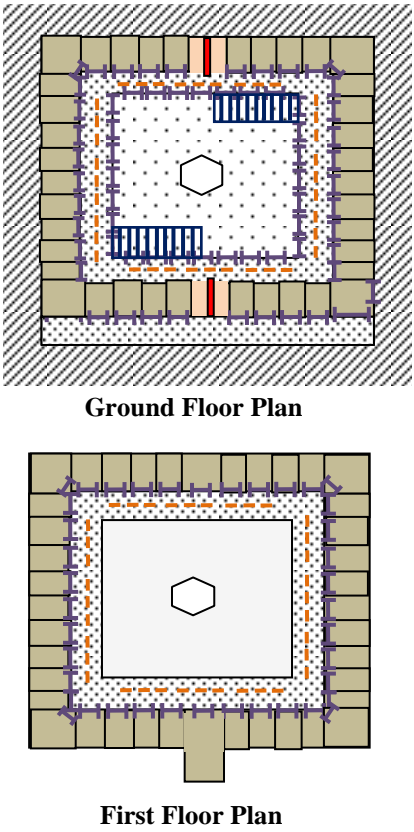











b. Ramps

There are no ramps existing.

c. Lifts

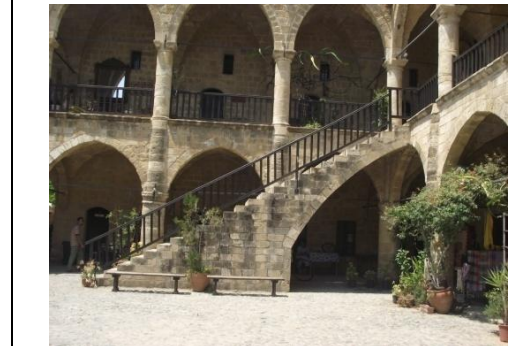
Great Khan does not have lifts within existing condition. The building is two storey building, so, it is necessary to adapt a kind of lift in terms of accessibility standards.

Table 12: Analysis of Great Khan

| 6 Great Khan | | Space Organization of the Building | | Photos of the Building | | | | | |
|---|---|--|--|---|---|--|-----------------------|--|---|
|  <p>Ground Floor Plan</p> <p>First Floor Plan</p> | | <p>KEY OF ORGANIZATION</p> <ul style="list-style-type: none">  Outdoor spaces  Semi-open spaces  Indoor spaces  Defined open spaces  Parking spaces  Pavements  Entrances  Lifts  Steps and stairs  Ramps  Entrance halls  Doors and passageways  Corridors/ pathways | |  <p>Outdoor space.</p> |  <p>Semi open space.</p> |  <p>Defined open space.</p> | | | |
| | |  <p>Indoor space (Shop).</p> |  <p>Semi open space.</p> |  <p>Defined open space (Stair).</p> | | | | | |
| Photos: Author, 2012. | | | | | | | | | |
| Circulation paths of outdoor spaces | | Circulation paths of semi-open spaces | | Circulation paths of indoor spaces | | Circulation paths of defined open spaces | | General condition and suggestions | |
|  | |  | |  | |  | | | |
| Parking Spaces | - | Horizontal circulation paths | Entrance halls | A | Entrance halls | - | Doors and passageways | | A |
| Pavements | - | | Doors and passageways | I | Doors and passageways | I | Pathways | | - |
| Outdoor ramps and stairs | - | | Corridors | A | Corridors | - | Steps and stairs | | I |
| Entrances | A | Vertical circulation on paths | Steps and stairs | - | Steps and stairs | - | Ramps | - | |
| | | | Ramps | - | Ramps | - | Lifts | - | |
| | | | Lifts | - | Lifts | - | Lifts | - | |

The building have problems on the vertical circulation.

The staircase that is in the defined open space create barrier for people.

It is expected to have a platform lift or chair lift.

4.7 Analysis of Bedesten According to Accessibility Standards

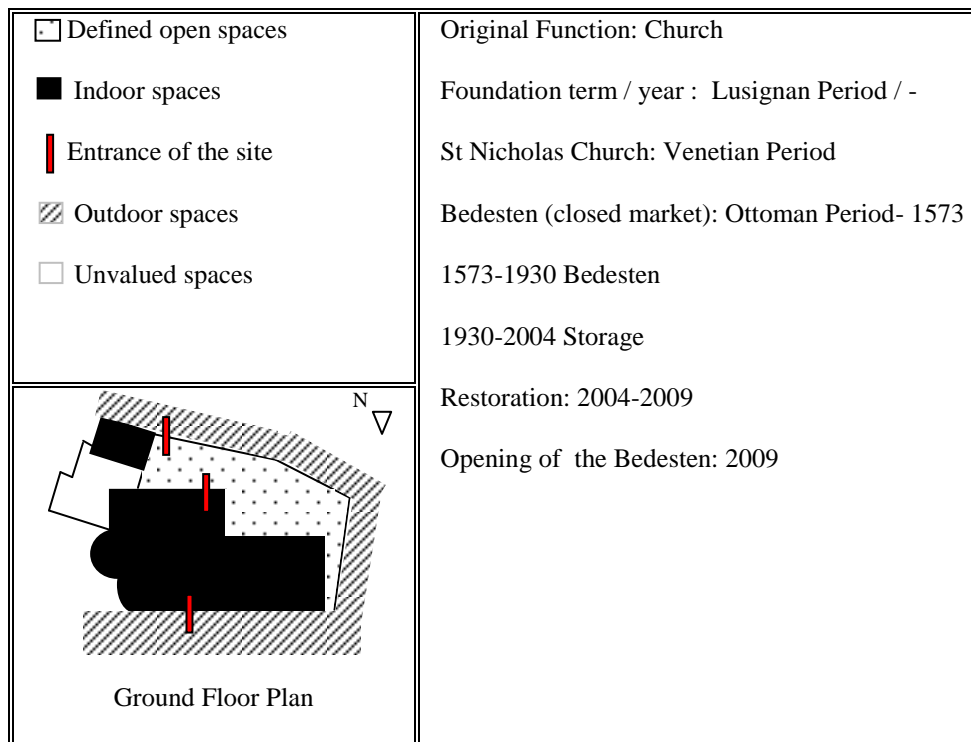

Figure 88: Information about Bedesten.

4.7.1 Analysis of Circulation Paths of Outdoor Spaces in relation with the Entrances

Bedesten does not have parking spaces, and ramps as well as stairs that belong to its site. There are two entrances to the courtyard (defined open space) from the back side of the building. One of them is on the South West, and the other is on the South East. Also, there are two entrances to the building. One of them is main entrance (North) which is enter to the indoor spaces of the building, and the other is back entrance (South) which is enter to the semi open space of the building that connects the indoor spaces and the courtyard of the building.

a. Parking Spaces

Bedesten does not have any space for parking. However, there is a parking area that locates on the back of the building, and it has relation with the building by courtyard. Also, people with disabilities may come from the back entrance (South West) of the site with their car or other vehicles.

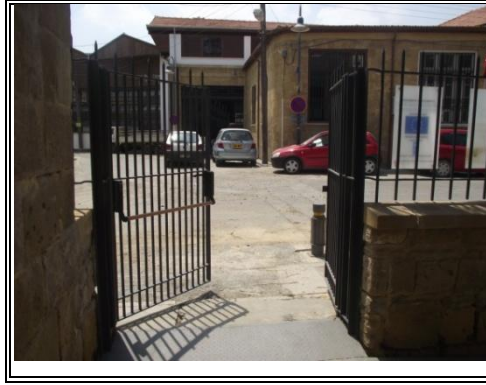

Figure 89: Back entrance of the site (South West), Bedesten (Author, 2012).

b. Pavements

There are pavements next to the both entrances of the building. Around the building, walking paths are defined with barriers.



Figure 90: Pavements, Bedesten (Author, 2012).

- There are not many level differences between street and pavement.

Pavements around the buildings are accessible from both building and street.

c. Outdoor Ramps and Stairs

There are no outdoor ramps and stairs around the Bedesten.

d. Entrances

Bedesten has two entrances, one of them (main entrance) is on the North, one of them is on the South.

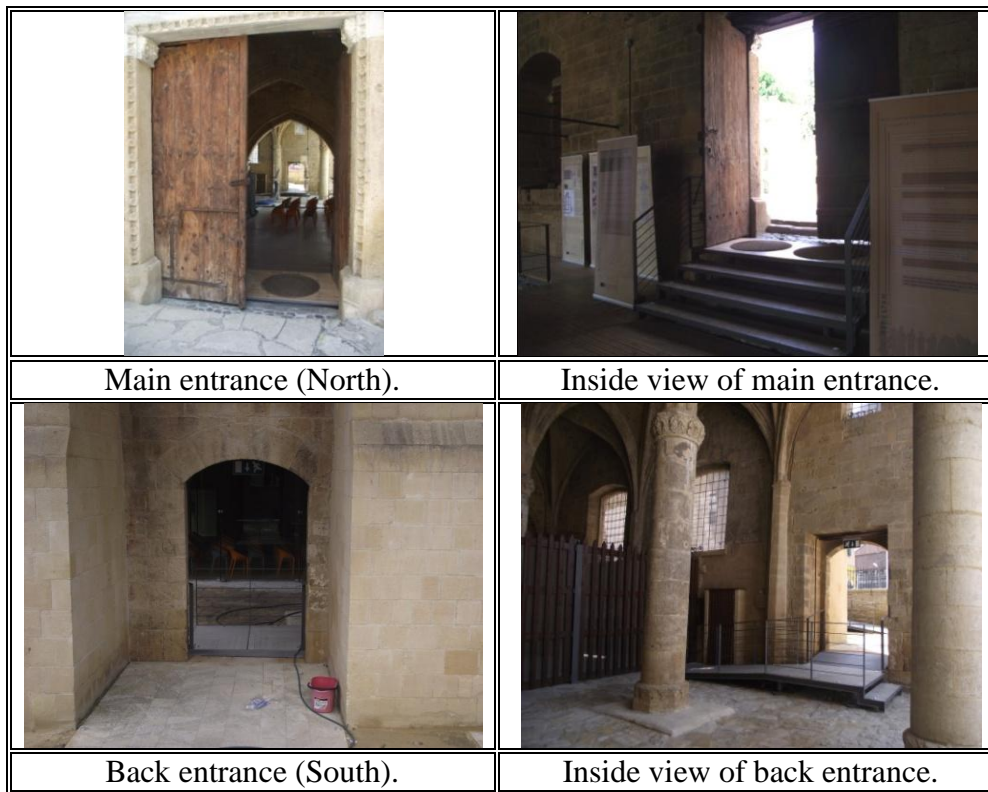

Figure 91: Entrances, Bedesten (Author, 2012).

- Main entrance door is not accessible, because there are steps after the door.
- The stair has accessible measurements; risers:17, goings:30, but there are no ramp or lift used with the stair, so the stair compose barrier for people who have physical disabilities.
- Back entrance is accessible; the width of the passageway is suitable, also there is a ramp which provide access for both indoor and courtyard by eliminating the level difference.

Although, main entrance is not accessible, it is possible to enter to the building from back entrance.

4.7.2 Analysis of Circulation Paths of Semi-Open Spaces

Bedesten has only one semi-open space which is next to back entrance. Semi open space is a transitional space between indoor spaces and courtyard.

4.7.2.1 Analysis of Horizontal Circulation

a. Entrance Halls

There is no entrance hall existing.

b. Corridors

There is a corridor that connects indoor spaces to the ramp area. The width of corridor is accessible and the space is empty for circulation.



Figure 92: Corridor in the semi open space, Bedesten (Author, 2012).

c. Internal doors and Passageways

There is a separating element that use for divide the indoor space and semi-open space. This element can open trough wall and it give permission for access. Also, passageways between columns are accessible for circulation.



Figure 93: Door in the semi open space, Bedesten (Author, 2012).

4.7.2.2 Analysis of Vertical circulation

a. Steps and Stairs

Level difference between courtyard and semi open space is solved with two steps and a ramp. (See Figure 94)

b. Ramps

There are two ramps in the site of the building. One of them is on the back entrance, and it provides accessibility to the building.

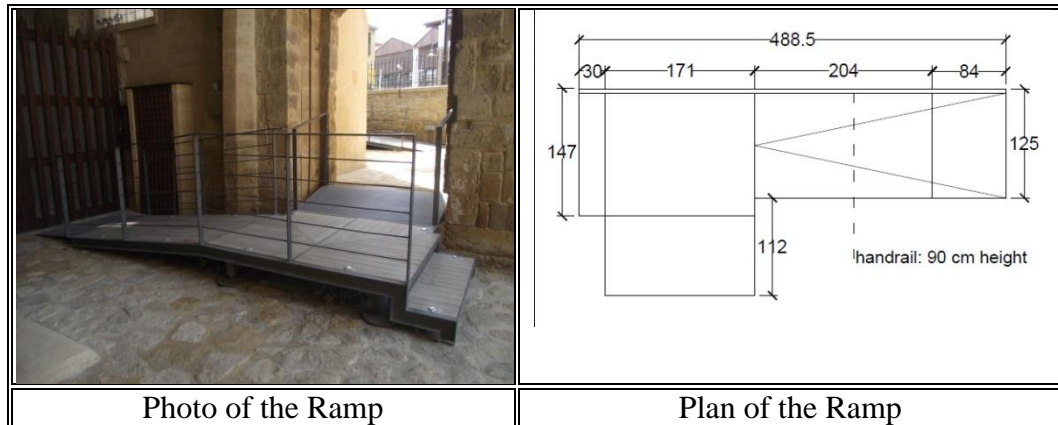

Figure 94: Ramp, Bedesten (Author, 2012).

- The ramp's slope, length, width, and handrail height have suitable measurements for people.

By using the ramp, people can enter to the courtyard of the building without facing any barrier.

c. Lifts

There are no lifts existing in the semi open space.

4.7.3 Analysis of Circulation Paths of Indoor Spaces

4.7.3.1 Analysis of Horizontal Circulation

a. Entrance Halls

There is no entrance hall.

b. Corridors

Circulation paths are consisted of corridors in the building. There are corridors between columns, between columns and walls, also between columns and sitting elements.



Corridor (next to the entrance).

Figure 95: Indoor corridors, Bedesten (Author, 2012).

- Widths and heights of the corridors are suitable for all of the activities that are done in the building.
- There is enough space to move in the building.

Corridors are accessible for circulation in the indoor spaces of the building.

c. Internal doors and Passageways

There is no internal door. There are passageways that generally consist of arches and columns.

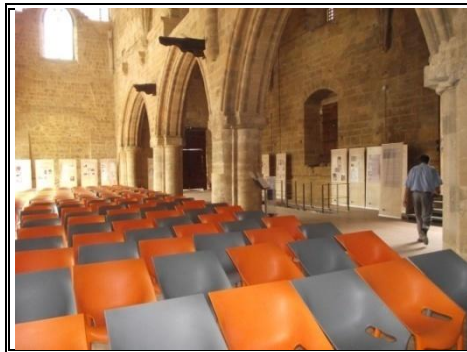

Passageways (next to the entrance).

Figure 96: Passageways of indoor spaces, Bedesten (Author, 2011).

- These passageways' widths are suitable for circulation.

Passageways provide accessibility of circulation between indoor spaces.

4.7.3.2 Analysis of Vertical circulation

a. Steps and Stairs

There are no steps or stairs inside of the building.

b. Ramps

Like steps and stairs, all ramps are located on transitional spaces and open defined spaces.

c. Lifts

There is not any lifts existed in the building.

4.7.4 Analysis of Circulation Paths of Defined Open Spaces

4.7.4.1 Analysis of Horizontal Circulation

a. Doors and Passageways

There are three doors in the courtyard of the building. One of them connects indoor and outdoor spaces; two of them connect the outdoor spaces and courtyard. Passageways generally consist of arches and columns.

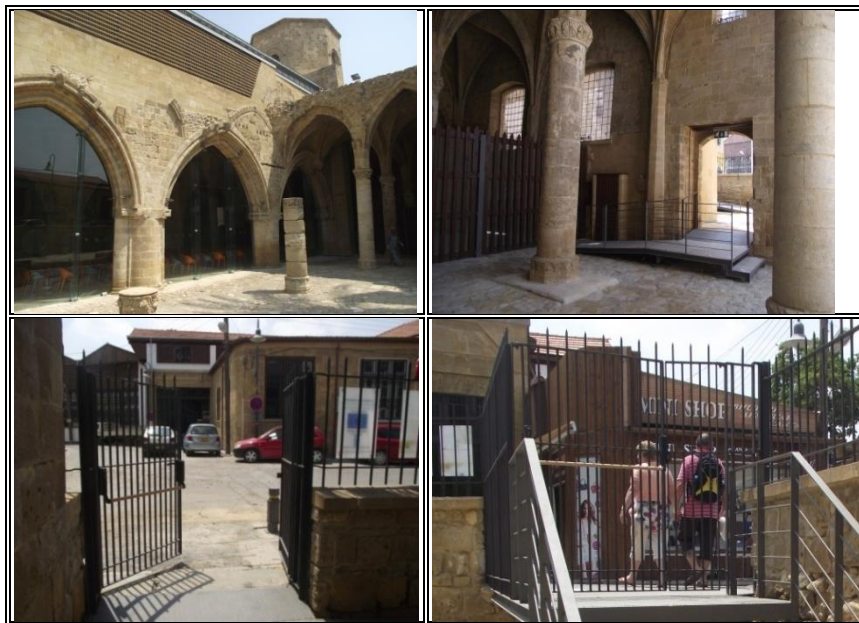

Figure 97: Doors and passageways in the defined open spaces, Bedesten (Author, 2012).

- All of the doors have accessible measurements about their widths.
- Passageways' widths are accessible for circulation.

b. Pathways

In the courtyard, there is a pathway that continues through the passageways (arches and columns).



Figure 98: Pathway in the defined open spaces, Bedesten (Author, 2012).

- Pathway has enough width for circulation in the courtyard.

4.7.4.2 Analysis of Vertical circulation

a. Steps and Stairs

There are two stairs that are related with defined open space of the building.



Figure 99: Steps and stairs in the defined open spaces, Bedesten (Author, 2012).

- Both of the stairs have suitable measurements as risers: 170mm and treads: 300mm.
- One of them have ramp at the same circulation route, and the ramp provide accessibility for this route.

Consequently, the stairs have accessible standards, but without ramps they may not use by physically disabled people.

b. Ramps

There are two ramps within the site of the building. One of the ramps is located in the courtyard of the building.



Figure 100: Ramp in the defined open space, Bedesten (Author, 2012).











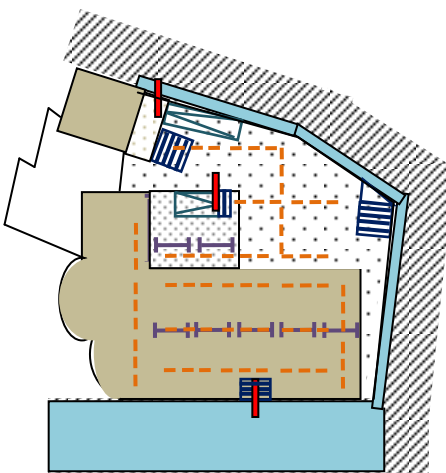











- The ramp's slope, length, width, and handrail height have accessible measurements.

By using the ramp, people can enter to the courtyard of the building without facing any barrier. In other words, it is also possible to enter to the building site from back side.

c. Lifts

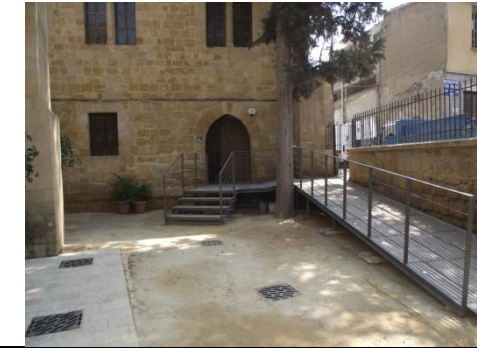
Bedesten does not have any lifts within existed condition. The building is one storey building, so, it is not necessary to adapt any kind of passenger lift. However, there are stairs as level difference within and around the building. One of them have ramp next to itself, but two of them don't have. Platform lifts may be suitable for this stairs. Internal wheelchair platform lift, stair wheelchair platform lift, and external wheelchair platform lift types can adaptable according to the location and features of stairs.

Table 13: Analysis of Bedesten

| 7 | | Bedesten | | Space Organization of the Building | | Photos of the Building | | | | | |
|--|--|---|--|--|--|---|--|--|--|--|--|
|  <p>Ground Floor Plan</p> | | | | <p>KEY OF ORGANIZATION</p> <ul style="list-style-type: none">  Outdoor spaces  Semi-open spaces  Indoor spaces  Defined open spaces  Parking spaces  Pavements  Entrances  Lifts  Steps and stairs  Ramps  Entrance halls  Doors and passageways  Corridors/ pathways | |  <p>Outdoor space. (Author, 2012)</p> | |  <p>Semi open space. (Author, 2011)</p> | |  <p>Defined open space. (Author, 2011)</p> | |
| | | | | | |  <p>Indoor space. (Author, 2011)</p> | |  <p>Semi open space (Ramp and back entrance).(Author, 2012)</p> | |  <p>Defined open space (Ramp and stair). (Author, 2012)</p> | |
| Circulation paths of outdoor spaces | | Circulation paths of semi-open spaces | | Circulation paths of indoor spaces | | Circulation paths of defined open spaces | | General condition and suggestions | | | |
|  | |  | |  | |  | | <p>The building have problems on the vertical circulation.</p> <p>The staircase that is on the entrance have accessible measurements but without ramp or lift it does not provide full access.</p> | | | |
| Parking Spaces | | - | | Entrance halls | | - | | | | <p>Doors and passageways</p> <p>A</p> | |
| Pavements | | A | | Doors and passageways | | A | | | | | |
| Outdoor ramps and stairs | | - | | Corridors | | A | | | | | |
| Entrances | | I A | | Steps and stairs | | I | | | | <p>Steps and stairs</p> <p>A I</p> | |
| | | Horizontal circulation paths | | Steps and stairs | | I | | <p>Ramps</p> <p>A</p> | | | |
| | | Vertical circulation paths on paths | | Ramps | | - | | <p>Lifts</p> <p>-</p> | | | |
| | | | | Lifts | | - | | | | | |

4.8 Analysis of the Eaved House According to Accessibility Standards

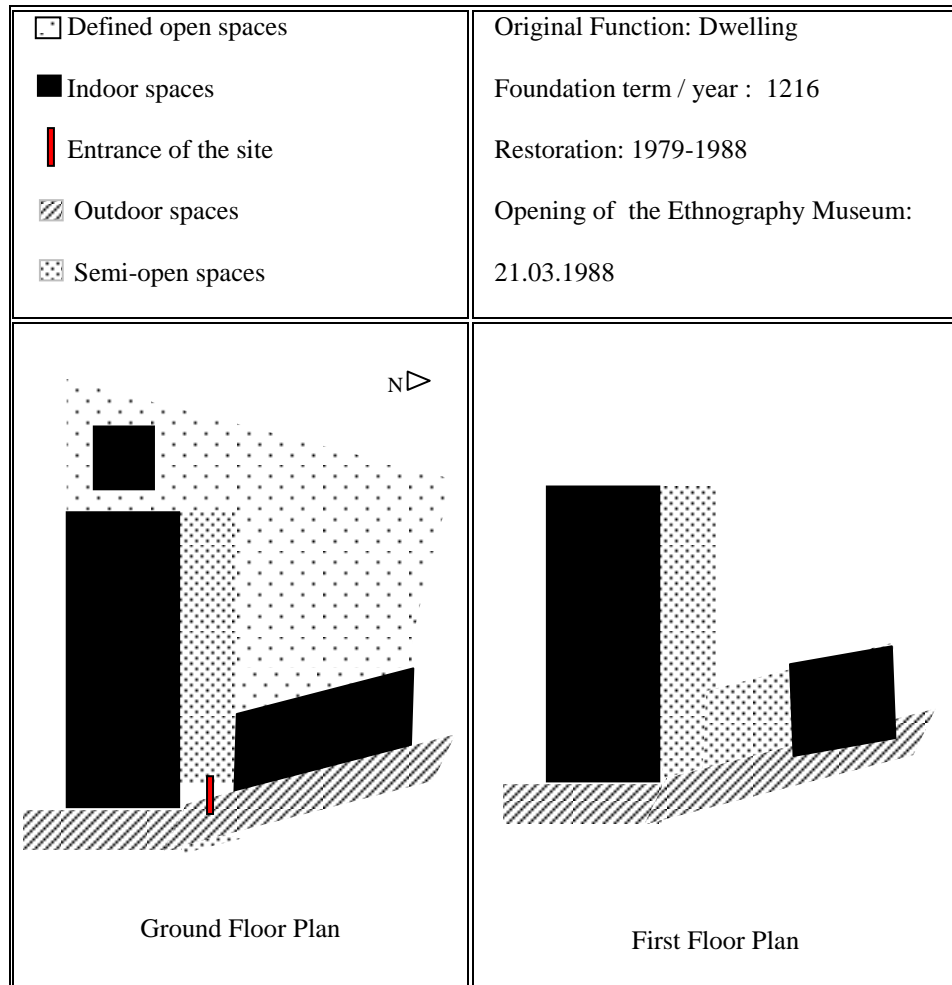

Figure 101: Information about the Eaved House.

4.8.1 Analysis of Circulation Paths of Outdoor Spaces in relation with the Entrances

The Eaved House does not have any parking spaces that belong to its site. There are two steps in front of the entrance of the building. There is one entrance which locates at the East of the building.

a. Parking Spaces

The Eaved House does not have any space for parking. However, there is a parking area that locates on the East of the building, and it has relation with the entrance of the building.

b. Pavements

There is no pavement around the building.

c. Outdoor Ramps and Stairs

There are two steps in front of the entrance of the building. These steps block the circulation from outside to inside.



Figure 102: Steps at the outdoor space of the building, The Eaved House (Author, 2012).

d. Entrances

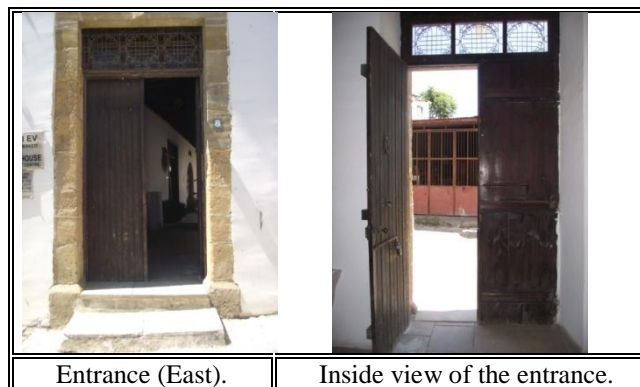

Figure 103: Entrances, The Eaved House (Author, 2012).

- Entrance is not accessible; the widths of the doors are suitable when two of them is open, but there are two steps that block the entrance of the building.

4.8.2 Analysis of Circulation Paths of Semi-Open Spaces

The Eaved House has one kind of semi open space. This space is a kind of semi open corridor that connects the indoor spaces to each other on the first floor. Also, on the ground floor it connects indoor spaces and courtyard. This semi open corridor names as 'Südüürme' in Cyprus.

4.8.2.1 Analysis of Horizontal Circulation

a. Entrance Halls

There is an entrance hall after entrance, the organization of the building can understand from the view of entrance hall.



Figure 104: Entrance hall, The Eaved House (Author, 2012).

- Design of the entrance hall gives information about location of functions in the building.

In other words, people can understand where the information is or where is the exhibition.

b. Corridors

Semi open spaces are consisted of corridors in The Eaved House.



Figure 105: Corridors in the semi-open spaces, The Eaved House (Author, 2012).

- Widths of corridors are usable by everyone.
- These corridors use for sitting on the ground floor.

Generally, circulation at the corridors is possible.

c. Internal doors and Passageways

Doors of the rooms open to the semi open spaces in the building.



Figure 106: Doors at the semi-open spaces, The Eaved House (Author, 2012).

- Doors have similar clear widths between 140 cm and 150 cm as total.
- There are two steps, and their heights are 18 cm.
- These steps hinder people to enter inside.

Door widths are accessible. However, the main room's interior has level difference. As a result, rooms are accessible except main room.

4.8.2.2 Analysis of Vertical circulation

a. Steps and Stairs

The stair of the building is located on the semi open space of the building.



Figure 107: Stair at the semi-open space, The Eaved House (Author, 2012).

- The stair has a very right angle, and treads are very narrow.
- The measurements of stair are not accessible.

Consequently, the stair does not provide accessible circulation.

b. Ramps

There are no ramps existing.

c. Lifts

There are no lifts existing.

4.8.3 Analysis of Circulation Paths of Indoor Spaces

4.8.3.1 Analysis of Horizontal Circulation

a. Entrance Halls

There is no entrance hall in the indoor spaces.

b. Corridors

There is no entrance hall in the indoor spaces.

c. Internal doors and Passageways

There are no internal doors and passageways in the indoor spaces.

d. Restrooms

There is no restroom in the indoor spaces.

4.8.3.2 Analysis of Vertical circulation

a. Steps and Stairs

There are no steps or stairs existing in the indoor spaces of the building.

b. Ramps

There are no ramps existing.

c. Lifts

There are no lifts existing.

4.8.4 Analysis of Circulation Paths of Defined Open Spaces

4.8.4.1 Analysis of Horizontal Circulation

a. Doors and Passageways

Passageways generally consist of arches and columns.



Figure 108: Passageways in the courtyard, The Eaved House (Author, 2012).

- These passageways' widths are accessible for circulation.
- However, there are one step level difference between semi open space and the courtyard.

Because of that level difference passageways do not provide accessible circulation between courtyard and semi open space.

b. Pathways

There are no pathways existing.

4.8.4.2 Analysis of Vertical circulation

a. Steps and Stairs

There are no steps or stairs existing in the open defined space of the building.











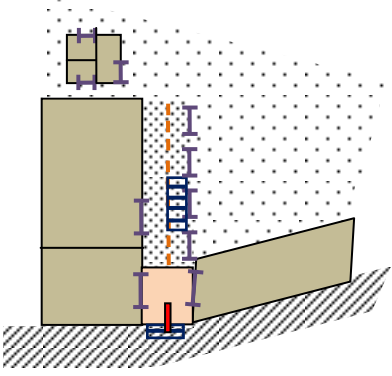
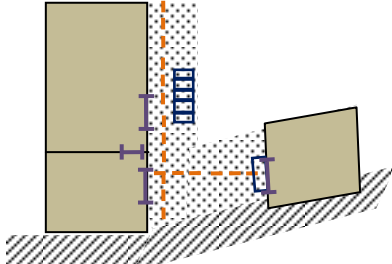









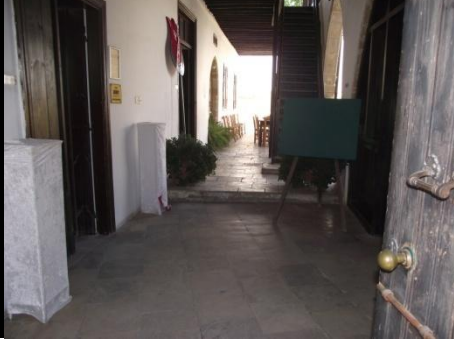

b. Ramps

There are no any ramps existing.

c. Lifts

The Eaved House does not have lifts within existing condition. The building is two storey building, so, platform lifts may be suitable to provide accessible circulation between ground floor and first floor. Also, the other alternatives may be an external wheelchair platform lift, a stair wheelchair platform lift, ora chair stair lift according to the location and features of the stair.

Table 14: Analysis of The Eaved House

| 8 | | The Eaved House | | Space Organization of the Building | | Photos of the Building | | | |
|---|---|--|-----------------------|---|-----------------------|---|-----------------------|--|---|
|  <p>Ground Floor Plan</p>  <p>First Floor Plan</p> | | <p>KEY OF ORGANIZATION</p> <ul style="list-style-type: none">  Outdoor spaces  Semi-open spaces  Indoor spaces  Defined open spaces  Parking spaces  Pavements  Entrances  Lifts  Steps and stairs  Ramps  Entrance halls  Doors and passageways  Corridors/ pathways | |  <p>Outdoor space.</p> | |  <p>Semi open space.</p> | |  <p>Defined open space.</p> | |
| | |  <p>Indoor space (Exhibition room).</p> | |  <p>Indoor space (Conference hall).</p> | |  <p>Semi open space (Stair).</p> | | | |
| Photos: Author, 2012. | | | | | | | | | |
| Circulation paths of outdoor spaces | | Circulation paths of semi-open spaces | | Circulation paths of indoor spaces | | Circulation paths of defined open spaces | | General condition and suggestions | |
|  | |  | |  | |  | | | |
| Parking Spaces | - | Horizontal circulation paths | Entrance halls | A | Entrance halls | - | Doors and passageways | A | The building have problems on the vertical circulation. The staircase that is on the semi open space have a problem about the slope. It is expected to adapt a chair lift to provide access to the first floor. |
| Pavements | - | | Doors and passageways | I | Doors and passageways | A | | | |
| | | Vertical circulation paths on paths | Corridors | A | Corridors | - | Pathways | - | |
| Outdoor ramps and stairs | I | | Steps and stairs | I | Steps and stairs | - | Steps and stairs | - | |
| | | | Ramps | - | Ramps | - | Ramps | - | |
| Entrances | A | Lifts | - | Lifts | - | Lifts | - | | |

4.9 Analysis of Lapidary Museum According to Accessibility Standards

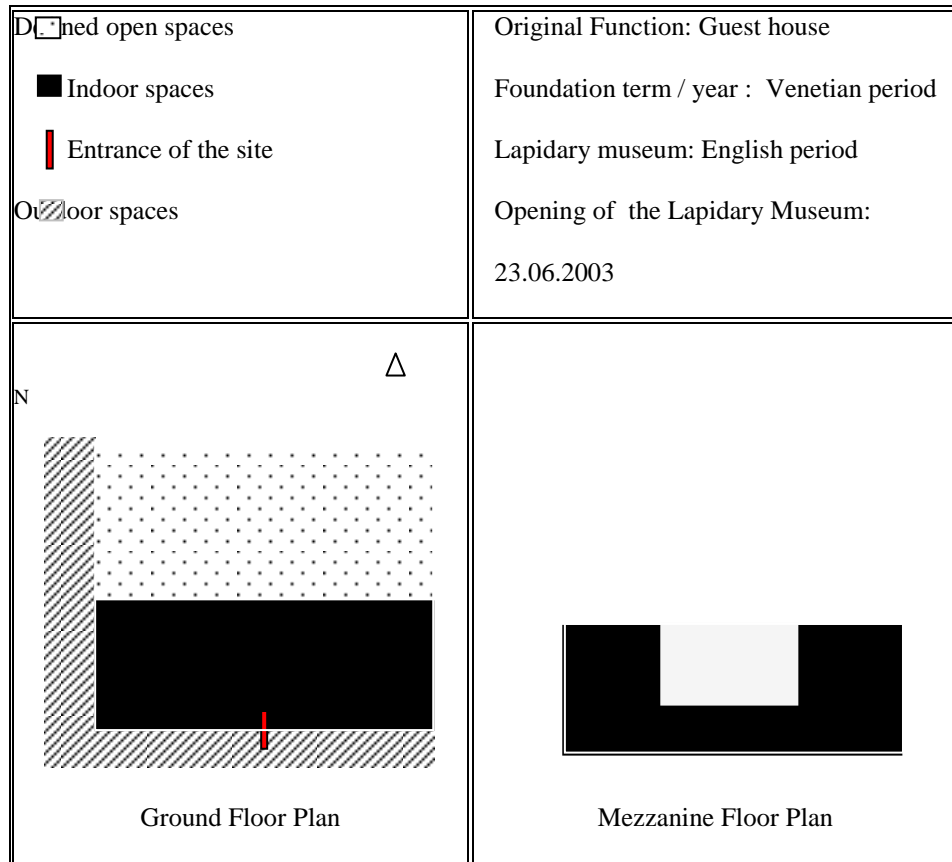

Figure 109: Information about Lapidary Museum.

4.9.1 Analysis of Circulation Paths of Outdoor Spaces in relation with the Entrances

Lapidary Museum does not have any outdoor spaces related with entrance. The building has one entrance that is on the South side of the building.

a. Parking Spaces

There is no parking space.

b. Pavements

There is a path around the building, but it is not suitable for walking.

c. Outdoor Ramps and Stairs

There are no outdoor ramps and stairs around the Museum.

d. Entrances

The museum has one entrance; the entrance is on the South facade of the building.

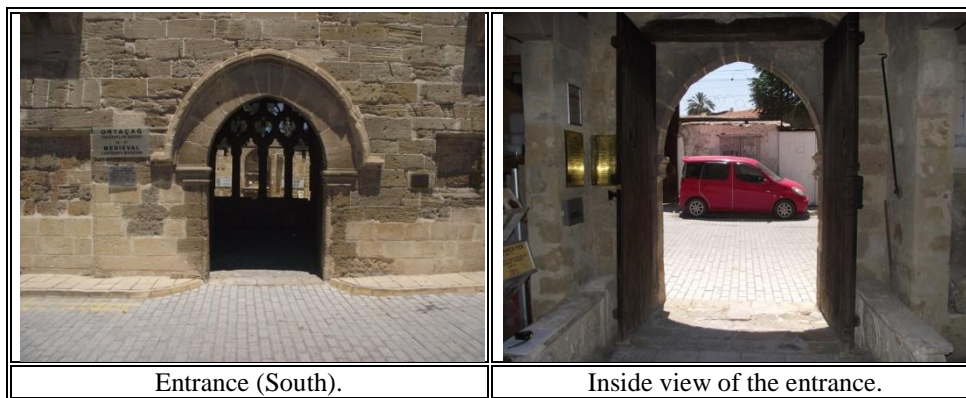

Figure 110: Entrances, Lapidary Museum (Author, 2012).

- Width of the entrance opening is suitable.
- There is no level difference between outside and inside of the building.

The entrance is accessible.

4.9.2 Analysis of Circulation Paths of Semi-Open Spaces

There are no semi-open spaces existing in the building.

4.9.3 Analysis of Circulation Paths of Indoor Spaces

Indoor spaces are consisted of ground floor spaces and mezzanine floor spaces.

4.9.3.1 Analysis of Horizontal Circulation

a. Entrance Halls

Indoor spaces do not have any defined entrance hall.

b. Corridors

The mezzanine floor of the building consists of a 'U' shaped corridor.



Corridor on the mezzanine floor of the building.

Figure 111: Corridor in the indoor spaces, Lapidary Museum (Author, 2012).

- Width of the corridor is more than 915mm and it is suitable for circulation.
- There are no level differences existing.

Corridor is accessible for circulation. However, the corridor is on the mezzanine floor, and it is difficult to reach the corridor.

c. Internal doors and Passageways

There is only one door that opens to the indoor spaces. The door is on the mezzanine floor.

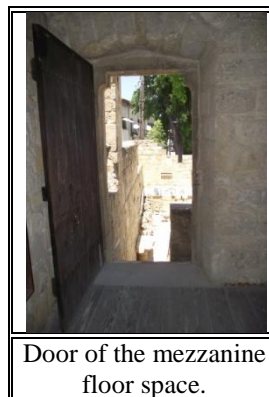

Door of the mezzanine floor space.

Figure 112: Door in the indoor space, Lapidary Museum (Author, 2012).

- Door does not have accessible standards.
- Before the door there is a stair in the defined open space.

Consequently, it is not possible to reach and use the door for physically disabled people.

4.9.3.2 Analysis of Vertical circulation

a. Steps and Stairs

There is no stair in the indoor spaces.

b. Ramps

There are no ramps existing.

c. Lifts

There are no lifts existing.

4.9.4 Analysis of Circulation Paths of Defined Open Spaces

4.9.4.1 Analysis of Horizontal Circulation

a. Doors and Passageways

There are two doors that open to defined open space. These doors are connections between indoor spaces and courtyard.



Views of the doors from courtyard.

Figure 113: Doors in the courtyard, Lapidary Museum (Author, 2012).

- Doors do not have suitable measurements for accessible circulation.

Doors do not provide accessible circulation between courtyard and indoor space.

b. Pathways

Lapidary Museum does not have pathways in the courtyard.

4.9.4.2 Analysis of Vertical circulation

a. Steps and Stairs

There is one stair in the defined open space of the building.



Stair from differnt views.

Figure 114: Stair in the defined open space, Lapidary Museum (Author, 2012).

- Stair has 13 steps; risers: 21 cm treads: 30 cm, and handrails' height 90 cm.

The stair does not have accessible standard about its risers. Also, there is not any ramp or lift existed next to the stairs. As a result, the stair is not accessible.



b. Ramps

There are no ramps existing.

c. Lifts

Lapidary Museum does not have lifts within the building site. The museum is a two storey building, so, it is necessary to adapt a kind of lift. If it is not possible to adapt a passenger lift because of the building' historical value, platform lifts may be suitable. However, the wideness of the stair is narrow (100 cm), so the external wheelchair platform lift can adapt next to the stair, or internal wheelchair platform lift can adapt to indoor space of the building.

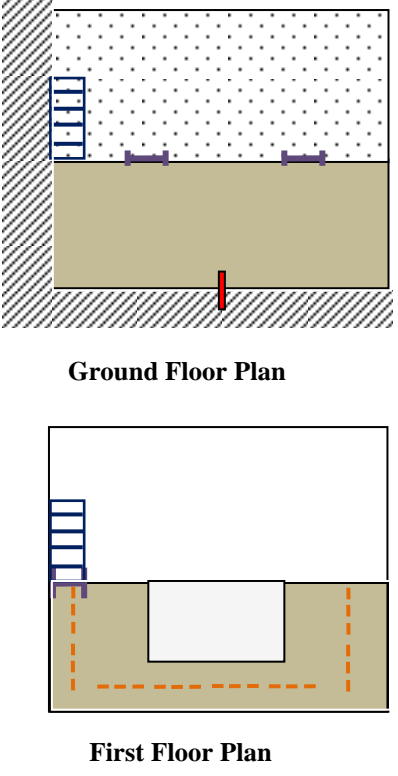
Table 15: Analysis of Lapidary Museum

| 9 Lapidary Museum | | Space Organization of the Building | | Photos of the Building | | | | | |
|---|---|---|-----------------------|---|-----------------------|---|-----------------------|--|---|
|  <p>Ground Floor Plan</p> <p>First Floor Plan</p> | | <p>KEY OF ORGANIZATION</p> <ul style="list-style-type: none"> Outdoor spaces Semi-open spaces Indoor spaces Defined open spaces Parking spaces Pavements Entrances Lifts Steps and stairs Ramps Entrance halls Doors and passageways Corridors/ pathways | |  <p>Outdoor space.</p> <p>Defined open space.</p> <p>Defined open space (Stair).</p> | | | | | |
| | | | |  <p>Indoor space.</p> <p>Indoor space (Mezzanine floor).</p> <p>Indoor space (Ground floor).</p> <p style="text-align: center;">Photos: Author, 2012.</p> | | | | | |
| Circulation paths of outdoor spaces | | Circulation paths of semi-open spaces | | Circulation paths of indoor spaces | | Circulation paths of defined open spaces | | General condition and suggestions | |
| | | | | | | | | | |
| Parking Spaces | - | Horizontal circulation paths | Entrance halls | - | Entrance halls | - | Doors and passageways | | I |
| Pavements | - | | Doors and passageways | - | Doors and passageways | I | | | |
| Outdoor ramps and stairs | - | | Corridors | - | Corridors | A | Pathways | | - |
| Entrances | A | Vertical circulation paths | Steps and stairs | - | Steps and stairs | - | Steps and stairs | I | |
| | | | Ramps | - | Ramps | - | Ramps | - | |
| | | | Lifts | - | Lifts | - | Lifts | - | |
| <p>The building have problems on the vertical circulation, and about widths of doors.</p> <p>The staircase that have problem about measurements of risers and treads.</p> <p>It is expected to adapt a chair lift to provide access to the first floor.</p> | | | | | | | | | |

4.10 Analysis of Lusignan House According to Accessibility Standards

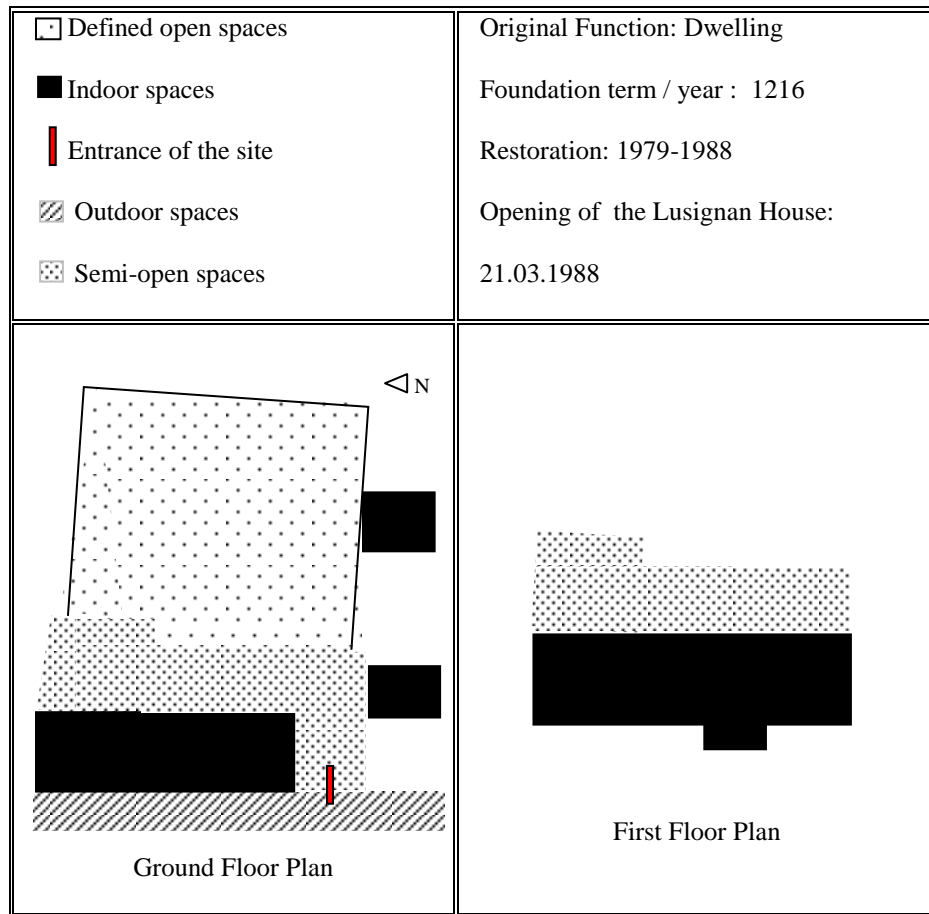

Figure 115: Information about Lusignan House.

4.10.1 Analysis of Circulation Paths of Outdoor Spaces in relation with the Entrances

Lusignan House does not have any outdoor spaces that related with its entrance.

There is one entrance which locates at the West of the building.

a. Parking Spaces

Lusignan House does not have any space for parking.

b. Pavements

There is no pavement around the building.

c. Outdoor Ramps and Stairs

There are no outdoor ramps and stairs.

d. Entrances

There is an entrance on the West of the building.



Figure 116: Entrances, Lusignan House (Author, 2012).

- Entrance door has 202 cm width and there is an 8cm step before entrance.

The entrance has suitable standards for accessible circulation.

4.10.2 Analysis of Circulation Paths of Semi Open Spaces

Lusignan House has one kind of semi-open space. This space is a kind of semi open corridor that connects the indoor spaces to each other on the first floor. Also, on the ground floor it connects indoor spaces and courtyard. This semi open corridor names as 'Sündürme'.

4.10.2.1 Analysis of Horizontal Circulation

a. Entrance Halls

There is an entrance hall after entrance, but it does not orientate people.

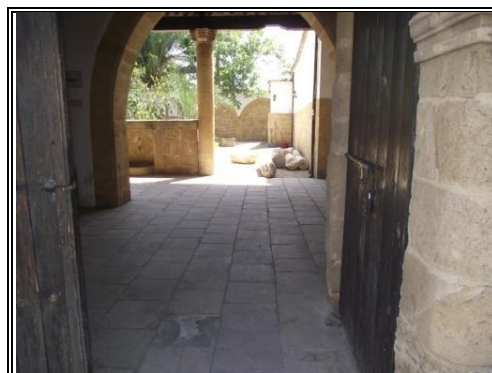

Figure 117: Entrance hall, Lusignan House (Author, 2012).

b. Corridors

Semi open spaces are consisted of corridors.



Figure 118: Corridors in the semi-open spaces, Lusignan House (Author, 2012).

- Generally, circulation at the corridors is possible.
- Widths of corridors are usable by everyone.

As a result, corridors are accessible on both ground floor and first floor in the building.

c. Internal doors and Passageways

There are several doors that open to the semi open spaces on the ground and first floors. However, doors are closed on the first floor, because the museum is closed to visit for a while.



Figure 119: Doors at the semi-open spaces, Lusignan House (Author, 2012).

- Doors have clear widths between 115 cm and 130 cm as total.
- However, on the first floor rooms have level difference with the corridor.

As a result, rooms are accessible on the ground floor, but on the first floor steps within the doors hinder people to enter inside.

4.10.2.2 Analysis of Vertical circulation

a. Steps and Stairs

The stair of the building is located on the semi open space of the building.



Figure 120: Stair at the semi-open space, Lusignan House (Author, 2012).

- There is difference between measurements of the steps.
- The stair does not have accessible standards about its risers or treads.

As a result, stairs are not accessible.

b. Ramps

There are no ramps existing.

c. Lifts

There are no lifts existing.

4.10.3 Analysis of Circulation Paths of Indoor Spaces

There are rooms as indoor spaces in the building. Rooms on the ground floor have been analysed. However, rooms on the first floor could not analyse because, they are closed.

4.10.3.1 Analysis of Horizontal Circulation

a. Entrance Halls

There are no entrance halls.

b. Corridors

There are no corridors.

c. Internal doors and Passageways

There are no internal doors and passageways.

4.10.3.2 Analysis of Vertical circulation

a. Steps and Stairs

There are no steps or stairs existing in the indoor spaces of the building.

b. Ramps

There are no ramps existing.

c. Lifts

There are no lifts existing.

4.10.4 Analysis of Circulation Paths of Defined Open Spaces

4.10.4.1 Analysis of Horizontal Circulation

a. Doors and Passageways

Passageways consist of columns. These passageways connect semi open spaces to the courtyard.

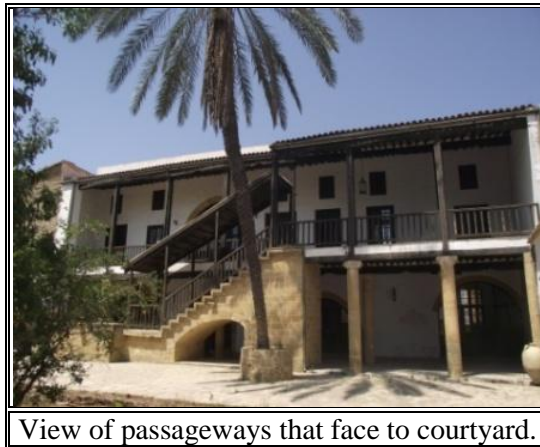

Figure 121: Passageways in the courtyard, Lusignan House (Author, 2012).

- These passageways' widths are accessible for circulation.

Circulation between courtyard and semi open space provides by these passageways.

b. Pathways

There are no pathways in the courtyard.

4.10.4.2 Analysis of Vertical circulation

a. Steps and Stairs

There are no steps or stairs existing in the open defined space of the building.







b. Ramps

There are no ramps existing.

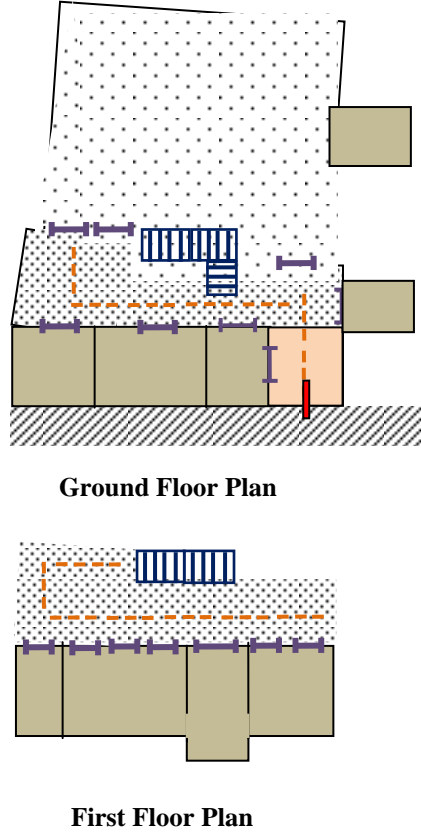
c. Lifts

Lusignan House does not have lifts within the building site. The building is two storey building, so, platform lifts may be suitable to provide accessible circulation between ground floor and first floor. Also, an external wheelchair platform lift, a stair wheelchair platform lift, or a chair stair lift may be the other alternatives according to the location and features of the stair.

Table 16: Analysis of Lusignan House

| 10 Lusignan House | | Space Organization of the Building | | Photos of the Building | | | | | |
|---|--|---|---|---|--|--|--|---|--|
|  <p>Ground Floor Plan</p> <p>First Floor Plan</p> | | <p>KEY OF ORGANIZATION</p> <ul style="list-style-type: none"> Outdoor spaces Semi-open spaces Indoor spaces Defined open spaces Parking spaces Pavements Entrances Lifts Steps and stairs Ramps Entrance halls Doors and passageways Corridors/ pathways | |  <p>Outdoor space.</p> |  <p>Semi open spaces.</p> |  <p>Defined open space.</p> | | | |
| | |  <p>Semi open space (Corridor on the first floor).</p> |  <p>Semi open space (Stair).</p> |  <p>Defined open space (Passageways).</p> | | | | | |
| Photos: Author, 2012. | | | | | | | | | |
| Circulation paths of outdoor spaces | | Circulation paths of semi-open spaces | | Circulation paths of indoor spaces | | Circulation paths of defined open spaces | General condition and suggestions | | |
| | | | | | | | | | |
| Parking Spaces | | Horizontal circulation paths | Entrance halls | A | Entrance halls | - | Doors and passageways | A | <p>Steps and restroom are the main accessibility problems of the building.</p> <p>The staircase have problem about measurements of risers and treads.</p> <p>It is expected to adapt a platform lift or chair lift to provide access to the first floor.</p> |
| Pavements | | | Doors and passageways | A I | Doors and passageways | - | Pathways | - | |
| Outdoor ramps and stairs | | | Corridors | A | Corridors | - | Steps and stairs | - | |
| Entrances | | Vertical circulation paths | Steps and stairs | I | Steps and stairs | - | Ramps | - | |
| | | | Ramps | - | Ramps | - | Lifts | - | |
| | | | Lifts | - | Lifts | - | Lifts | - | |

4.11 General Evaluation of Selected Buildings

Through the main aim of the study circulation paths of selected buildings have been analysed in terms of accessibility. The variations of evaluation aperture which are defined in Table 6 are taken into consideration of selected building' analysingin terms of accessibility standards.

In order to evaluate circulation paths of each historic buildings the chart (Table 6) has been constituted which includes categorization of spaces and components based on the circulation paths. The selected buildings have been analysed according to this evaluation chart (Table 6) in case of the common accessibility standards which are given in the Table 7 in chapter 3.

As a result, the accessibility conditions have been analysed for the selected public historic buildings. Those given information are the result of an accumulation of observation on shown evaluation which can be seen through those points:

- Semi open spaces have most accessible circulation among other spaces.
- Circulation of outdoor spaces in those buildings fail in accessibility standards.
- Horizontal circulations have more accessibility than vertical circulations.
- Main problems on vertical circulation paths are distinguished through steps, stairs and ramps.

Selected buildings have been observed with Table 6, which is prepared according to accessibility standards. Buildings have various problems about their circulations. Some general problems related with accessibility have been realized. These general problems are related with doors and passageways, steps and stairs, and ramps. Evaluation of all buildings collected on a matrix. Thus, accessibility conditions of buildings can be seen with this method in the Table 17.

Table 17: Analysis matrix of the buildings





| Circulation paths of outdoor spaces  | | | | | | | | | | Circulation paths of semi-open spaces  | | | | | | | | | | Circulation paths of indoor spaces  | | | | | | | | | | Circulation paths of defined open spaces  | | | | | | | | | | General condition and suggestions | | | | | | | | | | |
|---|---|---|---|---|---|---|----|---|---|---|---|---|---|---|----|---|---|---|---|--|---|---|----|---|---|---|---|---|---|--|----|--|--|--|--|--|--|--|--|---|---|--|--|--|--|--|--|--|--|--|
| Building numbers | | | | | | | | | | Building numbers | | | | | | | | | | Building numbers | | | | | | | | | | Building numbers | | | | | | | | | | | | | | | | | | | | |
| 1 | 2 | 4 | 6 | 7 | 8 | 9 | 10 | 1 | 2 | 4 | 6 | 7 | 8 | 9 | 10 | 1 | 2 | 4 | 6 | 7 | 8 | 9 | 10 | 1 | 2 | 4 | 6 | 7 | 8 | 9 | 10 | | | | | | | | | | | | | | | | | | | |
| Parking Spaces | | | | | | | | | | Horizontal circulation paths | | | | | | | | | | Entrance halls | | | | | | | | | | Entrance halls | | | | | | | | | | Doors and passageways | | | | | | | | | | Circulation of semi-open spaces are more accessible than other spaces, circulation paths of defined open spaces are more inaccessible than other spaces. |
| | | | | | | | | | | | | | | | | | | | | Doors and passageways | | | | | | | | | | Doors and passageways | | | | | | | | | | Doors and passageways | | | | | | | | | | |
| | | | | | | | | | | | | | | | | | | | | Corridors | | | | | | | | | | Corridors | | | | | | | | | | Pathways | | | | | | | | | | |
| Pavements | | | | | | | | | | Horizontal circulation paths | | | | | | | | | | Corridors | | | | | | | | | | Pathways | | | | | | | | | | Horizontal spaces in all spaces are more accessible than vertical spaces. In horizontal circulation spaces, doors and passageways have problems about accessibility. | | | | | | | | | | |
| Outdoor ramps and stairs | | | | | | | | | | Vertical circulation paths | | | | | | | | | | Steps and stairs | | | | | | | | | | Steps and stairs | | | | | | | | | | | Ramps and stairs are the most common problems as vertical circulation of the buildings. | | | | | | | | | |
| Entrances | | | | | | | | | | Vertical circulation paths | | | | | | | | | | Ramps | | | | | | | | | | Ramps | | | | | | | | | | | | | | | | | | | | |
| Lifts | | | | | | | | | | Vertical circulation paths | | | | | | | | | | Lifts | | | | | | | | | | Lifts | | | | | | | | | | It is expected that, stairs may have lifts or at least ramp which are adapted next to them to improve accessibility level of the buildings. | | | | | | | | | | |
| 11 > 5 A > I | | | | | | | | | | 14 > 9 A > I | | | | | | | | | | 6 < 11 A < I | | | | | | | | | | 10 < 15 A < I | | | | | | | | | | | | | | | | | | | | |

Table 18: Bar Charts of Analysis



Chapter 5

CONCLUSIONS

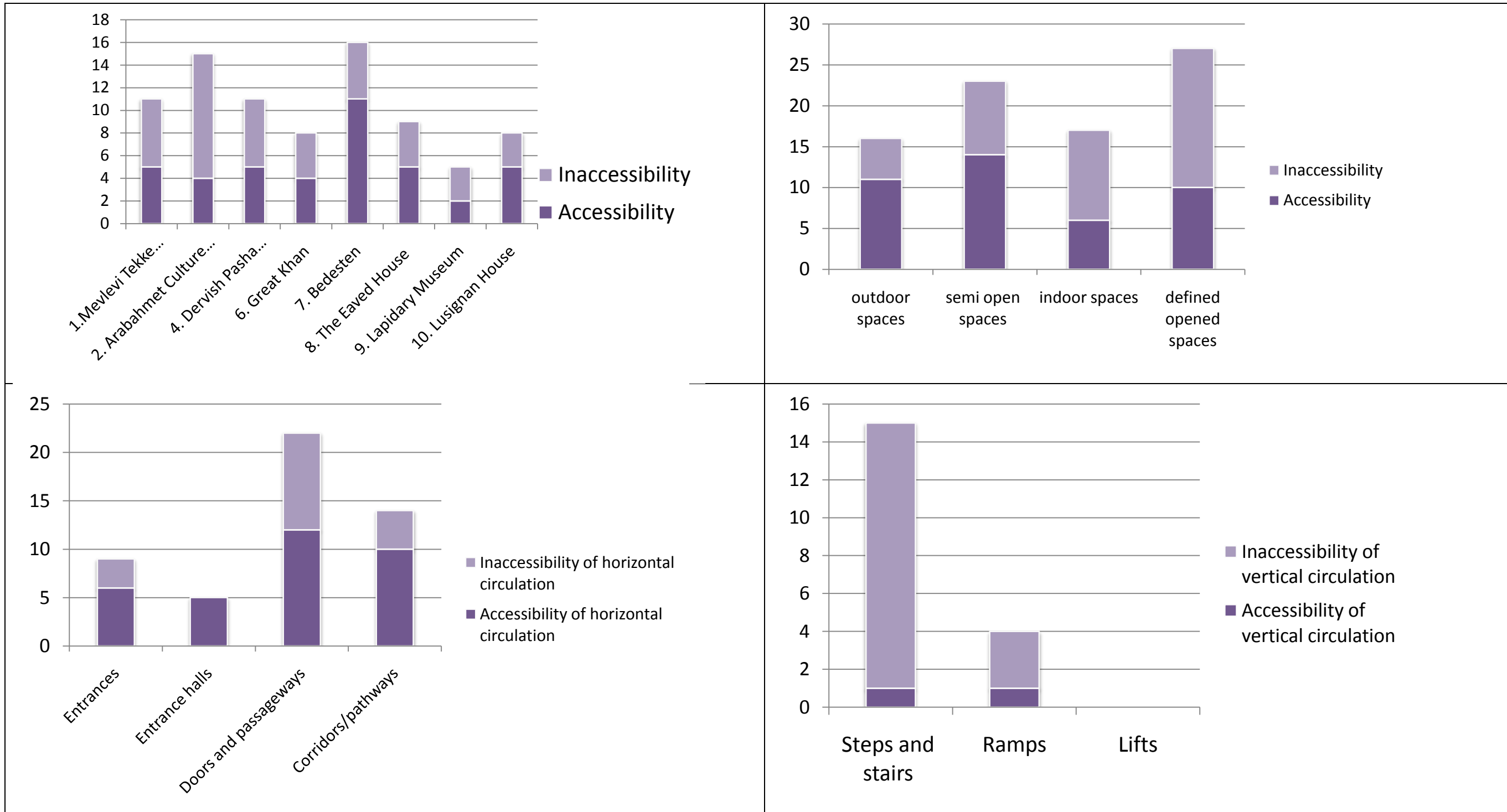
Necessities of human have played a significant role in the design process of a product, a space, a building, or a city through the history of design. Human has always been related with built environment. The problem is not only related with disabled people, but it is also related with people from different ages and abilities like, children and elderly people. However, differences among individuals had not been concerned until the middle of 20th century.

All people do not have equal abilities; various kinds of disabled people live around the world. The awareness of accessible design based on disability has been on the agenda since 1950's. Although, the awareness started 60 years before, unfortunately nowadays deficiency of accessibility standards cause problems in built environments. Developed countries have improved regulations about accessibility standards both for new and old built environments. It is significant to regulate and improve existing buildings by applying these standards in North Cyprus too.

This study has focused on accessibility standards about public buildings, and public historic buildings have been analysed in terms of variations of evaluation aperture which are defined in Table 7. Public historic buildings have important role among public buildings of a country, because they have both local and foreign users. It is important to re-use these buildings. However, they generally have problematic conditions about accessibility, and for this reason, people cannot access to these

buildings. Accordingly, it is required to improve existing conditions in terms of accessibility.

For the purpose of accessibility, selected public historic buildings have been analysed according to relation between circulation paths within spaces. When analysing buildings, this categorization of spaces as outdoor spaces, indoor spaces, semi open spaces, and defined open spaces was useful. Also, it was beneficial to analyse circulation as horizontal and vertical in chapter 3. When buildings were analysed, people with mobility impairments were selected as users, to increase the rate of accessibility.

As a result of observations on the sites, it is understood that there are several problems about both horizontal and vertical circulation of buildings. Especially, steps and stairs, ramps, restrooms, doors and passageways have various problems about accessibility. Observations have shown that, existing historic built environment of Northern part of Nicosia Walled City generally does not have proper accessibility for both disabled and other users.

Related with this subject, many studies have been done in the world but, in North Cyprus it is not concerned enough. Besides, the conducted researches are in urban level. Further studies are needed to improve accessibility conditions in public buildings, or to adapt accessibility standards to problematic buildings with the purpose of increasing the accessibility.

This research concludes that, it will be better to settle regulations about facilities of buildings both historical and contemporary, in terms of accessibility standards, to

make them accessible for all, and these regulations are also important for increasing the awareness of society.

Moreover, interior designers and interior architects are expected to design with the awareness of accessibility standards, accordingly these standards are expected to be a part of related education fields as theoretical. Also, for the professional works, it is expected to define a practical guide, and compose regulations according to this guide.

This study is believed to be beneficial both for designers and society. For designers and design students, it will be a guide about accessibility, and accessibility standards, significant guidelines about accessibility, and an observation sample about accessibility. For society, it is an attempt to increase the awareness about accessibility and its importance.

For further studies, it is possible to focus on disabled users, and conduct interviews with them to find main accessibility problems on site. The study may use these accessibility standards, for proposals of rehabilitation projects on this common matter.

REFERENCES

Adams, J., Foster, L. (June 2004). *Easy Access to Historic Buildings*, London: English Heritage.

Alderson,A. (April, 2010). *Stairs, ramps and escalators: Inclusive design guidance*. Centre for Accessible Environments, London: RIBA Publishing.

Bağışkan, T. (2005). *Kıbrıs'ta Osmanlı Türk Eserleri*, Lefkoşa: Mavi Basın Yayın Ltd.

BA, L, A. (March, 2004), *Designing for Accessibility: An essential guide for public buildings*, London:Centre for Accessible Environments.

Barbotte E. et al. "Prevalence of impairments, disabilities, handicaps and quality of life in the general population: a review of recent literature". *Bulletin of the World Health Organization*, 2001, 79: 1047–1055.

Barrier Free Environments. (1991). *UFAS Retrofit Manual*. Washington, DC.

Clarkson, J. (2003). *Inclusive design : design for the whole population*. London: Springer.

Department of Justice(September 15, 2010), *2010 ADA Standards for Accessible Design*,retrieved on September 25, 2011,from www.ada.gov

Department of Planning & Transportation, Department of Community Service. "*Improving access to listed buildings that in the City of London*". Retrieved on October 24, 2011, from http://www.heritage.vic.gov.au/admin/file/content2/c7/HVC015_Disability_Access_dc05.pdf

Douglas, J. (2006). *Building Adaptation*. Burlington: Elsevier.

Elottol, R.M.A., Bahauddin, A. (June, 2011), "*A Competitive Study on the Interior Environment and the Interior Circulation Design of Malaysian Museums and Elderly Satisfaction*", *Journal of Sustainable Development*, Vol.4, No:3, Canada: Canadian Center of Science and Education, retrieved from <http://journal.ccsenet.org/index.php/jsd/article/view/9449/7762>, on June 18, 2012.

English Heritage. (2004). "*Easy Access to Historic Buildings*". Retrieved on October 24, 2011, from <http://www.english-heritage.org.uk/publications/easy-access-to-historic-buildings/eeasyaccess2004.pdf>

Essex, S. (2011) "*Overcoming the barriers*". Retrieved from http://cadw.wales.gov.uk/docs/cadw/publications/Overcoming_the_Barriers_EN.pdf

Fischer, J., Meuser, P. (2009). *Design Manual Accessible Architecture*. Japan: Dom Publishers.

Goldsmith, S. (2000), *Universal Design: A Manual of Practical Guidance for Architects*, Architectural Press: London, UK.

Hanson, J.(2012), "*The Inclusive City: delivering a more accessible urban environment through inclusive design*". Retrieved on May 23, 2012, from <http://eprints.ucl.ac.uk/3351/1/3351.pdf>

Heritage Council of Victoria.(2008). "*Access for all to Heritage Places*" retrieved on October 24, 2011, from http://www.cityoflondon.gov.uk/NR/rdonlyres/86E81CC6-743A-4AC3-BB7B-D33E1AA58E5F/0/DP_PL_accessadvicenote.pdf

Jester, C.T.(September 1993). *Preservation Briefs* retrieved on September 26, 2011, from <http://www.nps.gov/history/hps/tps/briefs/brief32.htm>

NA. (2004), *City of Toronto Accessibility Design Guidelines*, retrieved from www.toronto.ca/diversity/accessibilityplan2003.

Newell, A. F., Gregor, P., Morgan, M., et al. (2011). User-Sensitive Inclusive Design. *Univ Access Inf Soc*, 10, 235-243.

Nyman, M; Chamayou, A (December 2011). "*The European Disability Forum*". Retrieved from www.edf-feph.org on April 15, 2012.

Park, J. Y. (2012). Design process excludes users: the co-creation activities between user and designer. *Digital Creativity*, 23, 1, 79–92.

Polili, Ö. (2012). *Rights Of Persons With Disabilities in North Cyprus*. Nicosia: Mavi Basım.

Preisser, W., Ostroff, E. (2001). *Universal Design Handbook*. New York: McGraw-Hill.

Siedle, J. H. (1996). *Barrier-Free Design: A manual for building designers and managers*. Oxford: Reed Elsevier.

Snider, Harold. Takeda, Nazumi. (2008). *Design for all: implications for bank operations*. Retrieved on February 25, 2011, from http://siteresources.worldbank.org/DISABILITY/Resources/Universal_Design.pdf

Story, M (1998). "*The Universal Design File: Designing for People of All Ages and Abilities*". Design Research and Methods Journal, The Centre for Universal Design: NC State University.

Uffelen, V. C. (2011). *Re-use Architecture*. Berlin: Braun Publishing AG.

URL 2.1: <http://oxforddictionaries.com>

URL 2.2: <http://www.takaonline.com/engeller-kalkiyor.html>

URL 2.3: http://www.e-laws.gov.on.ca/html/source/regs/english/2011/elaws_src_regs_r11191_e.htm

URL 2.4: http://ec.europa.eu/governance/impact/planned_ia/docs/2012_just_025_european_accessibiliy_act_en.pdf

URL 2.5: http://2.bp.blogspot.com/_4BBgprDvqmc/TKtWESp0sMI/AAAAA AAAAWM/M10U1IKhxgk/s200/180px-Curitiba_10_2006_05_RIT.jpg

URL 2.6: https://lh3.ggpht.com/c0QVipnWjwj8nIv_XiHOD5KgQHaLdS-O37QpVf3vZ7cYvWtZ7t02BJZZ3f-7MQtmbM3Lyq4=s85

URL 2.7: <https://lh5.ggpht.com/aL18zjvQnOLzNryv7i-aCVqv3RWauehmVlblXOcXaD3u69nCur3vZLNfjX4oz7gjsUTkFw=s101>

URL 2.8: http://media-cache-ec3.pinterest.com/upload/260082947200634980S1Wlr38X_b.jpg

URL 2.9: <https://lh6.ggpht.com/iHuDKLwu5NG2QxXENuZKgegvoIMHMFJF6F1dcfT7y7Eah-HGifNAxW9HIAOTO5BwL5zZuw=s114>

URL 2.10: https://lh6.ggpht.com/54c6tDRJH4UKOGniTQq0RvqrPU0WPI-Iuk2y1ke8t_p40hagvHJ2pyIgEr-TIDcbnIJE=s114

URL 2.11: https://lh6.ggpht.com/sXZUFTwusO6ZZE1GBol5i5J8uzX9tJ6kl8O6SkkSOF91uUbp_VyiE6JS-q7XzECqRnhdv0=s108

URL 2.12: https://lh3.ggpht.com/uEWi3JJqVvMxvA0Lc43THSfSS0gtD1GqImSLEIY_MebBB0is-YfjsCDhabBJZ5LITRYM7Q=s136

URL 2.13: https://lh5.ggpht.com/ihnw2qpGrvn9wR11E_xy8LX-fcacnADrMCOqNzJcTMjdBupDXyYSABz0JjIRaAzNmTPvAg=s127

URL 2.14: https://lh3.ggpht.com/_xvDZDgCV1QgmCJMIgc9uVZEKBenjDledab QqUTMWoL11QI3afaFVIjTuklj_dWyuOLYDg=s85

URL 2.15: <https://encrypted-tbn3.gstatic.com/images?q=tbn:ANd9GcRhpYx00-Vwr44Hlc2papLIXS0IGjMGPN3yliBNyxB1S7efuyYtmA>

URL 2.16: https://encryptedtbn1.gstatic.com/images?q=tbn:ANd9GcS7XZQhdGkh1n LTconH88jjtp9ky1yI4pPpCoSQf_vijTpMEMzD

URL 2.17: https://encrypted-tbn0.gstatic.com/images?q=tbn:ANd9GcS19dbjHo6NsImF24-ikbwAEGihczzW_0Cwhlr6vLKNBDZTxpBJ

URL 2.18: <http://medya.zaman.com.tr/2010/03/08/cocuk.jpg>

URL 2.19: https://lh3.ggpht.com/UFMat8DsBweNkuY2OLCsVCzsRSsvv5Sphn2LnjVw xHFaSMasId-WazghqB1WwsEHXc2q_Q=s85

URL 2.20: <https://lh3.ggpht.com/Jh597W2BP0ZFc4boxdReCRXirc6A4iIDTgyMnxR35hPzpqMt06FylSBN 6g9kWibSiwqJQ=s122>

URL 2.21: <http://www.extension.org/mediawiki/files/6/6e/Handle6.jpg>

URL 2.22: <http://www.erimas.com.tr/statiking/kucuk/sofia-doner-asansor-medya-galeri5.jpg>

URL 2.23: http://www.wood-furniture.biz/images5/snaidero_skylinelab_06.jpg

URL 2.24: http://www.armor-tile.com/imgs/home/Cross_walk.jpg

URL 2.25: <http://multippelsklerose.no/~media/Mobility/2%20man%20in%20wheelchair.ashx?20120215T1954139576>

URL 2.26: <http://www.un.org/disabilities/convention/conventionfull.shtml>

URL 3.1: http://4.bp.blogspot.com/-kUJydXiU3Fk/Tjb3Lst1KnI/AAAAAAAAAR4/LtoxR_CGubc/s1600/16958_5_Image6.jpg

URL 3.2: <https://lh3.ggpht.com/aQYszmNZvbOdV9G9jyqDBTm8BSbdZYdzxqU0mkHxEHabtj2TCe0C0TyIsxKu1U3Vuggw=s85>

URL 3.3: <https://lh3.ggpht.com/t3RyXq2VUDE9ITMzZwcpjV7ry-IIw91JBHvHtLIUuCMYzcn-Xkr0yQPqmX6Nz2eURSE8g=s114>

URL 3.4: https://lh6.ggpht.com/mqxILTQ4IK66aL2il7Yyo3U2KQ5iRRMnAbGsTrFa_-Fj3dJpvv8fFcLA8zpW4WVDZ8r10w=s119

URL 3.5: <http://www.independentliving.co.uk/ascendit/stairlifts.html>

URL 3.6: https://lh6.ggpht.com/01vh0ASq9r42eNugjMeS84SHRkPQvern83PfbYBzJnsF8sPXA9K_HD2fnBiNW6xXv9Q8A=s170

URL 3.7: <https://lh5.ggpht.com/SBpqQA2w3QTEGJkppq5WjmrIat7K8KvIJm812YBhQaGEnYZGrZFdgZex6ZR-mChqwgFlvinY=s85>

URL 3.8: https://lh5.ggpht.com/j186YY8mFbAE6uLaBUM_O0kkTKk5wDbtxkKxj-whMGwQ0K3NN6--6D_3-iCyMJnVmvzU=s85

URL 3.9: https://lh6.ggpht.com/BX-TY0em35hr5D5KAi2z3_T_Wfuq-DG1f82TaR_a-Vfo71TuzKcOubVsIaWhlerk5uZS53I=s85

URL 3.10: https://lh5.ggpht.com/LCQd_FnC6o7PFQXb5zhBUf4VoDrZ5w2qEVJ0baaP2DZhjdmGBZIOqnNCpiD1yQ6I4xIW=s85

URL 3.11: https://lh3.ggpht.com/Kzd5a20Flw5vR99qUxHeuP_7cFyAP3gVnic4ZIDjoL8OSIfKoRDdk3HXOkNPsZ9z1eLW22I=s85

URL 4.1: <http://peaceexchange.files.wordpress.com/2012/05/nicosia-aerial.jpg>

Wilkoff, Wm. L. (1994). *Practicing universal design an interpretation of the ADA*. New York: ITP.

WHO. (2011). World report on disability. Malta: WHO Press retrieved on November, 2011, from http://www.who.int/disabilities/world_report/2011/report.pdf

Architectural drawings of the buildings are taken from achieves of Departments of Antiquities and Museums, and Evkaf Foundation.

Bibliography

Adler, D. (2001). *Metric Handbook: planning and design data*. Oxford: Architectural Press.

Aslaksen, F., Bergh, S., Bringa, O. R., and Heggem, E. K. (1997). "Universal Design: Planning and Design for All" *GLADNET Collection*. Paper 327.

<http://digitalcommons.ilr.cornell.edu/gladnetcollect/327>

Bezzina, F., Spiteri, J. (2005). *Access for All: Design Guidelines*. Publication of National Commission Persons with Disability (www.knpd.org).

Bilge, B. (2011). İç Mekan Tasarım Kriterlerinin Belirlenmesinde Afet ve Acil Durum Risk Planlamasının Rolü. Ankara: Hacettepe Üniversitesi.

Eastern Paralyzed Veterans Association (U.S.). (1992). *Removing barriers in places of public accommodation*. Jackson Heights, NY : Eastern Paralyzed Veterans Association.

Erlanson, R. F. (2008). *Universal and accessible design for products, services, and processes*. Boca Raton: CRC Press

Foster, L. (1997). *Access to the Historic Environments-Meeting the Needs of Disabled People*. Shaftsbury: Donhead Publishing.

Imrie, R. (2006). *Accessible housing : quality, disability and design*. New York: Routledge.

Leibrock,C.A., Terry, J.E. (1999). *Beautiful Universal Design: A Visual Guide*. New York: John Willey and Sons.

Lebovich, W. L. (1993). *Design For Dignity: Studies in Accessibility*. New York: John Willey and Sons.

Lintack, R. F. (2006). *City of Hamilton: Barrier-Free Design Guidelines*. Canada.

N.A. (2006).*Planning and access for disabled people: a good practice guide*. London.

Ontario Ministry of municipal affairs and housing. Retrieved on January 15,2012, from <http://www.mah.gov.on.ca/Page1290.aspx>

Özmen B.B.(2005).Görme Engelliler İçin Konut İç Mekanları ve Donatı Elemanlarının Tasarım ve Biçimlenişi. Ankara: Hacettepe Üniversitesi.

Pheasant, S. T. (1986) *BodySpace: anthropometry, ergonomics and design*. Taylor & Francis.

Powell, K. (2005). *Architecture Reborn- The Conservation and Reconstruction of Old Buildings*. Hong Kong: Laurence King Publishing.

Sims, R. E. (2003). *'Design for All': methods and data to support designers*. PhD Thesis in Loughborough University.

Surhone, Lambert M.; Timpledon, Miriam T.; Marseken, Susan F.(2010). *Universal Design*. Gardners Books.

The Build For All: Reference Manual (2006). www-build-for-all.net

United States Election Assistance Commission.(2010). *Accessibility*. Washington, DC : U.S. Election Assistance Commission.

URL 1: http://www.toronto.ca/parks/pdf/engagement/accessibility_guidelines.pdf

URL 2: <http://www.designforall.org/en/downloads/dossier-DfA-Fd-ang.pdf>

URL 3: <http://design-dev.ncsu.edu/openjournal/index.php/redlab/article/view/130/79>

URL 4: <http://www.ncsu.edu/project/design-projects/udi/>

URL 5: <http://www.designforalleurope.org>

URL 6: <http://www.idd.ie/>