

Learning from Comparative Examples of Passive Houses in Different European Countries

Diler Haji Morad

Submitted to the
Institute of Graduate Studies and Research
in partial fulfillment of the requirements for the Degree of

Master of Science
in
Architecture

Eastern Mediterranean University
February 2014
Gazimağusa, Northern Cyprus

Approval of the Institute of Graduate Studies and Research

Prof. Dr. Elvan Yılmaz
Director

I certify that this thesis satisfies the requirements as a thesis for the degree of Master of Science in Architecture.

Prof. Dr. Özgür Dinçyürek
Chair, Department of Architecture

We certify that we have read this thesis and that in our opinion it is fully adequate in scope and quality as a thesis for the degree of Master of Science in Architecture.

Assist. Prof. Dr. Harun Sevinç
Supervisor

Examining Committee

1. Asst. Prof. Dr. Halil Zafer Alibaba

2. Asst. Prof. Dr. Polat Hançer

3. Asst. Prof. Dr. Harun Sevinç

ABSTRACT

The rising energy prices and energy consumption caused the interest about buildings with low energy consumption such as passive house. Furthermore, due to the decrease of fossil fuels, mainly energy consumption of the building sector derives from fossil fuel, and the residential buildings are making around 27% of the total consumption in Europe (Eurostat, 2011). So the residential buildings in Europe need energy savings. The realized passive house in different countries are examples to understand the reasons of this usage. Learning from the case studies is significant for the future development of passive house standard for other countries. Therefore, this work analyzes comparison of passive houses in different European countries, by choosing several case studies of passive house standard in hot and also cold climate zones. Based on the analysis passive house is a sustainable and suitable energy saving concept, which can be utilized in the context of Europe. Due to the examples of passive house, it can save more than 62% of primary energy consumption in the residential building for Europe, in addition to the point that the investigation showed that passive house standard is climatically, technologically and economically for the selected European countries suitable.

KeyWords: Passive house, Passive House Standard, Energy Efficiency.

ÖZ

Enerji ücretinin artması ve tüketimi, “Pasif Ev” denilen düşük enerji tüketen binalar yapma ilgisini uyandırdı. İnşaat sektörünün enerji tüketiminin çoğu fosil kaynaklarından oluştuğu ve fosil kaynaklarının azalması nedeni ile Avrupa’daki toplam tüketimin %27 sini yerleşke binaları oluşturmaktadır (Eurostat, 2011). Bu yüzden, Avrupada’ki yerleşke binalarının enerji tasarrufuna ihtiyaçları vardır. Farklı ülkelerdeki “Pasif Evler” ise buna bir örnektir. Araştırmalardan çıkan sonuçlar doğrultusunda ileride diğer ülkelerdeki “Pasif Evlerin” oluşmasına yol gösterir. Bu bağlamda, bu araştırma da Avrupa’daki farklı ülkelerdeki “Pasif Evleri” sıcak ve soğuk iklimlere göre karşılaştırıp analiz etmektedir. Analizlerden yola çıkarak, “Pasif Evlerin” Avrupa çerçevesinde enerji tasarrufu için uygun ve sürdürülebilir olduğu ortaya çıkmıştır. “Pasif Ev” örneklerine göre, Avrupadaki yerleşke binalarında %62’ye kadar enerji tasarrufu sağlamaktadır. Araştırma sonucuna göre ise, iklim, teknoloji ve ekonomik açıdan “Pasif Evlerin” Avrupa ülkelerine uygun olduğu ortaya çıkmıştır.

Anahtar Kelimeler: Pasif Ev, Pasif Ev Standardı, Enerji Etkinliği

ACKNOWLEDGMENTS

I would like to express my thanks and sincere gratitude to my supervisor Assist. Prof. Dr. Harun Sevinç, for his expert guidance, invaluable support and contributions in the preparation of this thesis.

I want to thank also my dear family, especially my parents, for their support and encouragement during my study.

I am thankful to my friends and the ones who supported and helped me to learn as well.

TABLE OF CONTENTS

ABSTRACT	iii
ÖZ.....	iv
ACKNOWLEDGMENTS	v
LIST OF FIGURES	xiii
LIST OF TABLES	xviii
LIST OF DIAGRAMS	xx
1 INTRODUCTION	1
1.1 Research Problem	1
1.2 Research Aim and Questions	1
1.3 Research Structure Methodology.....	2
1.4 Limitations and Scope.....	2
1.5 Literature Review.....	3
2 ENERGY EFFICIENCY ISSUES	5
2.1 Energy Efficient Buildings	5
2.2 Energy Use in Buildings	6
2.3 Energy Use and Environment	7
2.4 Energy Use and Shortage Problem	8
2.5 The Use of Renewable Energy Sources.....	10
2.6 Building Standards (Codes) and Regulations	10

2.7 The Importance of Building Energy Standards	12
2.8 The European Passive House.....	13
2.9 Definition of a European Passive House	13
2.10 Passive House Standards.....	15
2.11 Energy Efficiency Requirements for Passive House	19
2.11.1 Super Insulation	19
2.11.2 Thermal Bridges.....	21
2.11.3 Airtight Construction	23
2.11.4 Windows and Doors.....	25
2.11.5 Ventilation Systems	26
2.11.6 Economical Aspect	30
2.12 Passive Solar Systems in Passive House	32
2.12.1 Solar Heating.....	32
2.12.2 Use of Passive Solar Heating Systems in Passive House.....	33
2.12.2.1 Direct Gain	33
2.12.2.2 Indirect Gain Passive Systems.....	35
2.12.2.3 Isolated Gain Passive Systems	36
2.12.3 Use of Passive Solar Cooling Systems in Passive Houses	39
2.12.3.1 Natural Ventilation	39
2.12.3.2 Thermal Mass	41

2.12.3.3 Solar Control	41
2.12.3.4 Evaporative Cooling	42
2.12.3.5 Indirect Evaporation	43
2.12.3.6 Green Roofs	44
2.12.3.7 Earth Cooling.....	44
2.12.3.8 Hybrid Cooling	45
2.13 Use of the Passive Solar Design in Passive House	45
2.13.1 Typology/Shape (Compactness).....	45
2.13.2 Orientation	49
2.13.3 Building Indoor Arrangement in the Northern Hemisphere	52
2.13.4 Landscaping	53
2.13.5 Passive House Building Envelope	55
2.13.6 Roof.....	55
2.13.6.1 Solar Shade	55
2.13.6.2 Solar Reflection	56
2.13.6.3 Thermal Insulation.....	57
2.13.6.4 Summary.....	59
2.13.7 External Wall	59
2.13.7.1 Solar Shade	59
2.13.7.2 Solar Reflection	60
2.13.7.3 Insulation	60

2.13.8 Window	63
2.13.8.1 Orientation	63
2.13.8.2 Shading Device	63
2.13.8.3 Size	66
2.13.8.4 Ventilation (Air Movement)	67
2.13.8.5 Daylighting	68
2.13.8.6 Glazing	69
3 ANALYSIS OF PASSIVE HOUSE STANDARDS IN DIFFERENT EUROPEAN COUNTRIES AND CLIMATIC REGIONS	71
3.1 Case Studies	71
3.1.1 Spain	72
3.1.1.1 Granada's Climate Conditions	72
3.1.1.2 Granada (Moraleda) Passive House	73
3.1.1.3 Building Shape	74
3.1.1.4 Orientation and Building Arrangement	74
3.1.1.5 Exterior Wall	75
3.1.1.6 Roof	76
3.1.1.7 Floor	76
3.1.1.8 Glazing Façade and Shading	77
3.1.1.9 Thermal Comfort: Thermal Bridge - Air Tightness	78
3.1.1.10 Heating & Ventilation	79
3.1.1.11 Domestic Hot Water	79

3.1.1.12 Energy Performance	80
3.1.1.13 Economy and Cost.....	80
3.1.2 Germany	81
3.1.2.1 Hannover's Climate Condition.....	81
3.1.2.2 Building Shape	82
3.1.2.3 Orientation and Building Arrangement	83
3.1.2.4 Construction and Thermal Envelope	84
3.1.2.5 Exterior Wall	85
3.1.2.6 Floor Slab	85
3.1.2.7 Roof	86
3.1.2.8 Glazing Façade: Shading, Type and Frame.....	86
3.1.2.9 Thermal Comfort: Thermal Bridge - Air Tightness	87
3.1.2.10 Domestic Hot Water (DHW).....	88
3.1.2.11 Ventilation	88
3.1.2.12 Energy Performance	89
3.1.2.13 Economy and Cost.....	90
3.1.3 Sweden	91
3.1.3.1 Gothenburg Climate Conditions.....	91
3.1.3.2 Building Shape	92
3.1.3.3 Orientation and Building Arrangement	93
3.1.3.4 Exterior Wall	93

3.1.3.5 Basement Floor / Floor Slab.....	94
3.1.3.6 Roof	94
3.1.3.7 Glazing Façade: Shading, Type and Frame.....	94
3.1.3.8 Domestic Hot Water (DHW).....	95
3.1.3.9 Ventilation	96
3.1.3.10 Thermal Comfort: Thermal Bridge - Air Tightness	96
3.1.3.11 Energy Performance	97
3.1.3.12 Economy.....	97
4 ANALYSIS AND RESULTS	98
4.1 Main Learnings from the Investigation and Analysis of Three Existing Passive House Buildings in Different European Countries and Climates	98
4.1.1 Climate	98
4.1.1.2 Cooling (Summer).....	99
4.1.2 Building Shape.....	100
4.1.3 Orientation	100
4.1.4 Building Arrangement.....	100
4.1.5 Roof.....	101
4.1.6 Wall.....	101
4.1.7 Window and Shading	102
4.1.8 Domestic Hot Water Supply (DHW).....	103
4.1.9 Thermal Comfort: Thermal Mass	103
4.1.10 Ventilation	103

4.1.11 Airtightness.....	104
4.1.12 Passive Solar Heating and Cooling	104
4.1.13 Energy Performance and Economical Aspect	106
4.1.14 Summary.....	106
5 CONCLUSION	108
REFERENCES	111

LIST OF FIGURES

Figure 1: Map of Certified Passive House Buildings in Europe (http://www.passivehouse-international.org/index.php?page_id=288)	13
Figure 2: Passive house criteria (PHI, Passive House requirements, 2012).....	17
Figure 3: Thickness comparison between several insulation materials. (http://www.sealedairspecialtymaterials.com/na/en/products/vacuum-insulated-panels.aspx).....	20
Figure 4: Thermal-bridge avoidance in passive house (ISOVER, 2008).....	22
Figure 5: Thermal-bridge section in a passive house (PHI, 2006b)	22
Figure 6: How to avoid heat-loss and mold or moisture in passive-houses (PHI, 2006d)	24
Figure 7: Blower door test (ISOVER, 2008).....	24
Figure 8: Passive house window (PHI, 2006e)	25
Figure 9: HRV (Heat Recovery Ventilator)	27
Figure 10: Energy Recovery Ventilator (ERV) (Venmar, 2012)	27
Figure 11: System concept for supply and extract air system with heat-recovery (HRV) (PHI, 2006f)	28
Figure 12: Cross-ventilation principle concept with supply and extract air (PHI, 2006f)	28
Figure 13: The diagram of ventilation system: “Stale air (pink) is removed permanently from the rooms with the highest air pollution. Fresh air (orange) is supplied to the living rooms” (PHI, 2006f).....	29
Figure 14: Single sided ventilation (Roaf, 2001)	40

Figure 15: Cross flow ventilation (Roaf, 2001).....	40
Figure 16: Stack ventilation (Brown, 2001)	41
Figure 17: Left: Cooling with thermal mass; Right: Night cooling with high thermal- mass (Brown, 2001)	41
Figure 18: Solar Control: a- Interior venetian blind, b- Exterior venetian blind, c- Louvers and overhangs, d- Trees and vegetation. (Brown, 2001)	42
Figure 19: Evaporative cooling and natural ventilation (www.builditsolar.com).....	43
Figure 20: Left: Green roof; Right: Green roof, natural ventilation and evaporative cooling (www.builditsolar.com)	44
Figure 21: Earth cooling with evaporative cooling and natural ventilation (www.builditsolar.com)	44
Figure 22: Hybrid cooling: A- Geothermal heat pump; B- Subsoil heat exchanger (earth cooling).(www.geothermalenergypump.com).....	45
Figure 23 Building form for different climates (Al-khishali, 2010)	47
Figure 24: The effect of envelope to volume ratio on energy efficiency (http://localimpactdesign.ca/?page_id=48)	48
Figure 25: Shading effect for different type of trees (American Institute of Architects, 2012) (Gut, 1993)	53
Figure 26: Wind control by trees (Brown, 2001)	54
Figure 27: Absorption of heat by different surface materials: (a) Paving; (b) Grass; (c) Bare ground (American Institute of Architects, 2012)	54
Figure 28: Roof shading components in hot climate regions (Watson, 1983)	56
Figure 29: Reflective foil under the roof sheeting (www.townsville.qld.gov.au/resources).....	57

Figure 30: The arc of sun radiation in different seasons in northern latitudes (www.tomorrowshomes.net).....	57
Figure 31: Different positions of roof thermal insulation (Passive-On, 2007).....	58
Figure 32: Efficiency of movable and fixed-shading devices (American Institute of Architects, 2012)	64
Figure 33: Basic shading strategy for a south elevation. (http://www.wbdg.org/references/fhpsb_guidance.php).....	66
Figure 34: Locations of the case studies (Passive- on, 2007).....	71
Figure 35: Granada location (37°35'N latitude, 05°00'W longitude) (Google earth)	72
Figure 36: Granada weather (http://www.weather-and-climate.com/average- monthly-Rainfall-Temperature-).....	73
Figure 37: Granada passive house elevations: (a) South; (b) East; (c) West; (d) North (Assyce, 2010).....	74
Figure 38: Granada passive house plans (Assyce, 2010)	75
Figure 39: Cross-section of exterior wall and diagram of heat protection (http://www.u-wert.net).....	75
Figure 40: Roof section and diagram of heat protection (http://www.u-wert.net) ...	76
Figure 41: Floor section and diagram of heat protection (http://www.u-wert.net) ...	76
Figure 42: Granada passive house shading device (Construible, 2010).....	77
Figure 43: Thermal bridge testing in Granada passive house (Assyce, 2010)	78
Figure 44: Summer and winter strategy of Granada passive house (Construible, 2010)	79
Figure 45: Granada passive house DHW (Construible, 2010).	79
Figure 46: Hannover's location (52° 22'N latitude, 9° 44' 'W longitude) (Google earth)	81

Figure 47: Hannover weather data (http://www.weather-and-climate.com/average-monthly-Rainfall-Temperature-).....	82
Figure 48: Architectural concept, north and south view (IEA, 2011a)	83
Figure 49: Hannover passive house plans and section (Heiduk, 2009).....	84
Figure 50: Hannover passive house exterior wall cross section (Heiduk, 2009)	85
Figure 51: Hannover passive house floor slab cross section (Heiduk, 2009)	86
Figure 52: Hannover passive house roof cross section (Heiduk, 2009)	86
Figure 53: Details and cross-section of Hannover thermal-bridge (IEA, 2011a).....	87
Figure 54: Hannover thermal performance (Heiduk, 2009).....	88
Figure 55: Hannover domestic hot water (DHW), solar hot water storage and supply-air heater (SAH). (Heiduk, 2009).....	88
Figure 56: Diagram ventilation system in Hannover passive house (HEIDUK, 2009)	89
Figure 57: Gothenburg location (Latitude: 57°43'N, Longitude: 11°59'E) (IEA, 2011)	91
Figure 58: Gothenburg weather data (http://www.weather-and-climate.com/)	92
Figure 59: Architectural concept, north and south view (Janson, 2009).....	92
Figure 60: Gothenburg passive house plans (IEA, 2011).....	93
Figure 61: North and south façade windows (Janson, 2009)	94
Figure 62: Window frame (Janson, 2009).....	95
Figure 63: Gothenburg passive house solar collector (Janson, 2009).....	95
Figure 64: Ventilation system in Gothenburg passive house. (Constructing- Excellence, 2007).	96

Figure 65: Functional organisation of the passive house

http://vbn.aau.dk/files/60383597/2011_02_02_Samlet_afhandling_Camilla_Brunsgaard.pdf 100

Figure 66: Best orientation and major glass area (Author) 102

LIST OF TABLES

Table 1: Criteria for passive house (PHI, 2008)	17
Table 2: Insulation thickness and windows U-value for different passive-houses in different locations (Golunovs, 2009)	19
Table 3: Building material thickness with U-value 0.13W/m ² K (Feist, 2006b).....	20
Table 4: Lifecycle cost (Passive-On, 2007)	31
Table 5: Direct gain types and classification (Bainbridge & Haggard, 2011) (Roaf, 2001)	33
Table 6: Direct-gain advantages and disadvantages (Lapithis, 2004).....	34
Table 7: Indirect gain types and classification (Bainbridge & Haggard, 2011) (Roaf, 2001)	35
Table 8: Indirect gain advantages and disadvantages (Lapithis, 2004).....	36
Table 9: Sunspace gain types and classification (Bainbridge & Haggard, 2011) (Roaf, 2001)	37
Table 10: Sun-space gain advantages and disadvantages (Lapithis, 2004).....	38
Table 11: Climate zone classification (Mathu, 2003)	47
Table 12: Typical heat-losses for different external walls and the annual costs caused by heat-loss in external-walls with areas of 100m ² (Feist, 2006b)	61
Table 13: Different positions of wall-insulations (Al-Homoud, 2005).....	62
Table 14: Average indoor air-velocity as a percentage to wind velocity outdoor (Brown, 2001)	68
Table 15: Windows types and their characteristics (PHI, 2012)	70
Table 16: Energy performance for Gothenburg passive house (Janson, 2010).....	97
Table 17: A climate comparison between passive house examples (Author)	99

Table 18: Building constructions and components compared between passive house examples (Author).....	104
Table 19: Strategies compared between passive house examples (Author).....	105
Table 20: An energy performance comparison between passive house examples (Author).....	106
Table 21: The characteristic features of passive house (Author)	107

LIST OF DIAGRAMS

Diagram 1: Residential space heating requirement estimates for European countries (Evcil, 2012).....	6
Diagram 2: Europe energy consumption by sector (Eurostat, 2011)	7
Diagram 3: Energy loss through walls and roof in Europe (Evcil, 2012)	7
Diagram 4: Global climate in the 21st century (Ottmar, 2012).....	8
Diagram 5: Left, worldwide energy consumption; Right, oil prices in 2012 in dollars (Tverberg, 2013)	9
Diagram 6: The increase of energy use compared to population growth (Tverberg, 2013)	9
Diagram 7: Effects of using building standards (Mure, 2011).....	12
Diagram 8: Comparison of energy consumption in different buildings (Wilson, 2013)	15
Diagram 9: Annual energy cost (Feist, 2007)	31
Diagram 10: Relationship between building form and heat-loss (Steemers, 2003)..	46
Diagram 11: Effect of the length/width ratio on cooling load (Karasu, 2010).....	47
Diagram 12: Effect of different glazing-qualities in the south-façade of a passive house (PHI, 2006e).....	67
Diagram 13: Performance of Granada passive house (Passive House Database, 2013)	80
Diagram 14: Energy performance (Heiduk, 2009).....	90
Diagram 15: Additional investment of Hannover passive house (Heiduk, 2009).....	90
Diagram 16: Gothenburg passive house energy performance (Janson, 2010)	97

Chapter 1

INTRODUCTION

1.1 Research Problem

The growing energy prices, number of people and energy consumption with limited energy sources (fossil fuels) caused the interest about buildings with low energy consumption such as passive house. Energy demand in households accounts for around one fourth of the final energy needs in the Europe (Eurostat, 2011), and requires less energy consumption. At the same time, environment protection with a reduction of CO₂ emissions nowadays is becoming a requirement for new built buildings.

1.2 Research Aim and Questions

The aim of this study is to analyze and determine the important issues in the design process of energy efficient residential to achieve less energy consumption, as well as to explore the passive house requirements, and at the same time to evaluate the suitability of passive house standard in different European countries.

To achieve the objectives, the following questions are important:

- What is a passive house?
- Is the passive house climatically, technologically and economically suitable for European countries?
- How can passive house be implemented to improve energy efficiency of buildings in different European countries?

1.3 Research Structure Methodology

The first chapter is the introduction.

The second chapter is the literature review part: It includes essentially a wide-range literature review on books, scientific journal papers, articles, documents, thesis (Master, PhD) and research projects in understanding the passive house and other energy-efficient buildings.

The third chapter is the analysis part about selected case studies from different European countries (Germany, Spain, Sweden) located in hot and cold climate zones.

The fourth chapter is the analysis part about the results from the selected case studies: It includes a comparison between passive house measurements and the performance, which is needed to figure out the suitability of passive house for different European countries.

The fifth chapter: This chapter includes the conclusions.

1.4 Limitations and Scope

The limitation and scope of this study is to learn about passive house requirements and its standards in hot and cold climate zones by means of several case studies in different European countries. The main focus is to become more competent about energy-efficiency issues and especially about passive house.

1.5 Literature Review

After the realisation of the first passive house in Darmstadt – Kranichstein (Germany) in 1991, the ‘Passive House Institut’ in Germany published many articles and research materials about the implementation of ‘Passive House’.

Because of the 15th anniversary of the Darmstadt - Kranichstein Passive House, Feist (2006a) published information material about this project. At the same time, the same author published articles about the definition of passive house standard based on his realised first project in Darmstadt – Kranichstein (1991) (Feist, 2006).

Further publication is existing about another constructed passive house project in Hannover-Kronsberg (Germany), which is describing the construction process and measurements results (Feist, 2003). Special publications have been done about the use of thermal insulation materials for passive house (Feist, 2006b) and about economical aspects of passive house in order to analyse the economical advantages and disadvantages (Feist, 2007).

The ‘Passive House Institut’ publications are related to German passive house standards and its evaluations.

The use of ‘Passive House’ in other European countries was enhanced by important projects. For instance the PEP (Promotion of European Passive Houses) supported the development of passive houses in many European countries (PEP, 2006). This project includes only the European countries, which are located in the cold climate zone of Europe. Informations about the European countries located in hot climate

zone of Europe are not available. This project is partially supported by the European Commission under the Intelligent Energy Europe Programme.

Another important research analysis is the comparison between traditional building construction and passive house construction exemplified for Sweden regarding the building cost and construction efficiency (Boqvist et al., 2012).

Furthermore, the increase of thermal mass to achieve high thermal comfort of a passive house was analysed in South-Western Sweden. A five storey building was used as case study to reduce its energy consumption (Anderson et al., 2012).

All this scientific publications are related to passive house development in cold climate zones, so there is a need to establish the passive house in hot climate zones with appropriate standards.

Chapter 2

ENERGY EFFICIENCY ISSUES

2.1 Energy Efficient Buildings

Achieving energy-efficiency in residential buildings helps to decrease the overall energy consumption. The aims of energy efficiency in residential buildings are the reduction of energy consumption for cooling, heating and lighting, but also improves the comfort-level for the occupants. Therefore, energy efficiency can be defined as having minimum level of energy inputs (Umar, 2013). In general, energy efficiency in buildings can be achieved by high performing building envelopes such as using high performance windows, increasing the level of insulation, avoiding thermal bridges, airtight construction and getting use of bio-climatic architecture e.g. choosing the optimal compactness and orientation. The objectives for passive use of solar energy and usage of renewable energy sources also can be achieved by high performance ventilation systems such as heat recovery and mechanical insulation (Isover, 2013).

For improving energy efficiency in buildings, many approaches and concepts have emerged in the last decade, which include as passive house, bio-climatic, and green building design in the last decades. These approaches mainly focus on climate types. World-wide, there are different types of climate, i.e. there are different levels of heating and cooling energy loads in the buildings. Adopting design strategies for

energy efficiency in a climate having hot humid summers and cold winters is difficult as the building requires both heating and cooling systems. (Evcil, 2012)

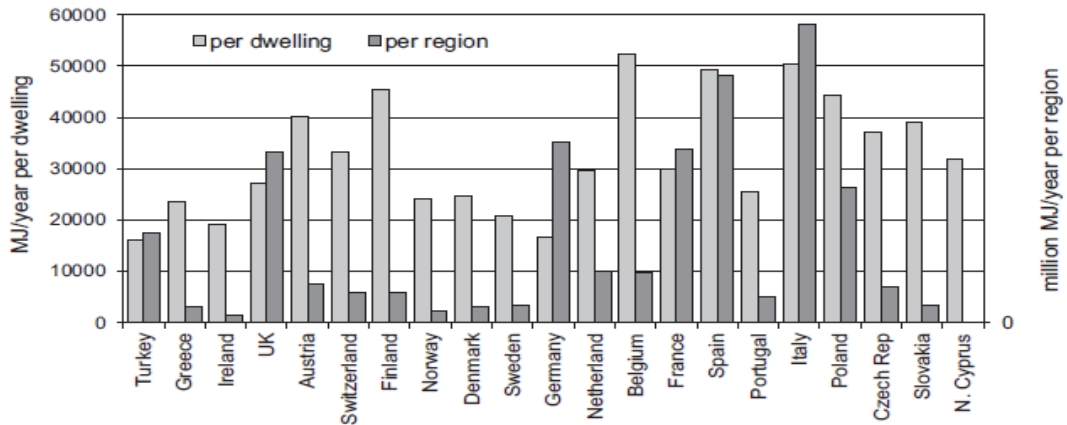

Diagram 1: Residential space heating requirement estimates for European countries (Evcil, 2012)

2.2 Energy Use in Buildings

Buildings are accountable for approximately 40% of the total annual energy consumption in the world. This energy is mainly used for provision of cooling, heating and lighting (Eurostat, 2011). In the residential sector, energy consumption is one of the basic constituents of the total energy consumption in European countries by the percentage of 27% (Diagram 2). According to the International Energy Agency, annual energy usage in the world has increased in residential buildings from 1995 to 2005 by 2.4% (Eurostat, 2011).

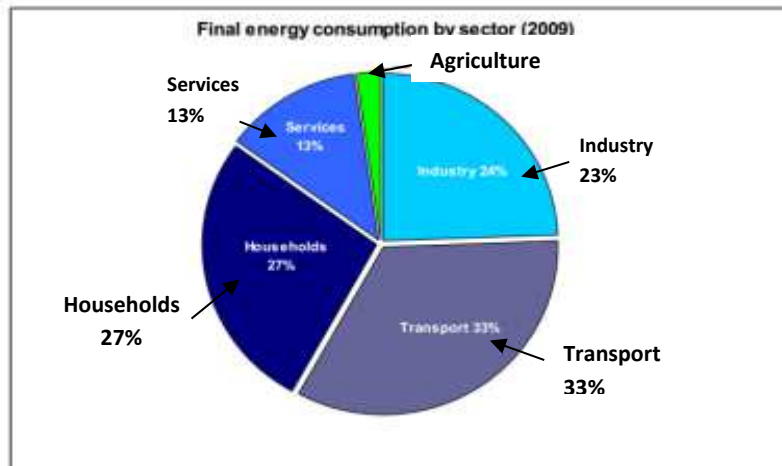

Diagram 2: Europe energy consumption by sector (Eurostat, 2011)

Reduction of energy demand and energy consumption in buildings is the key factors in reducing the depletion of natural resources and limiting emission pollutants. The following diagram shows European Union target for wall and roof energy loss.

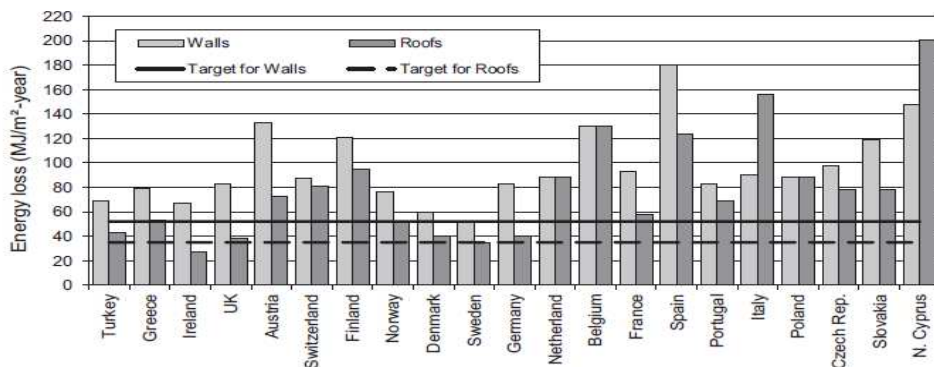

Diagram 3: Energy loss through walls and roof in Europe (Evcil, 2012)

2.3 Energy Use and Environment

The buildings, which have excessive usage of energy, are the main contributors to the present environmental pollution problem. A building which gains electricity energy by using fossil fuels causes soil, water and air pollution, and then is responsible for global-warming. Another issue is the effect it has on climate change: it is estimated that during the period of 1990 to 2100, global average surface-temperature will rise from 1.4 to 5.8°C (Diagram 4) (Ottmar, 2012).

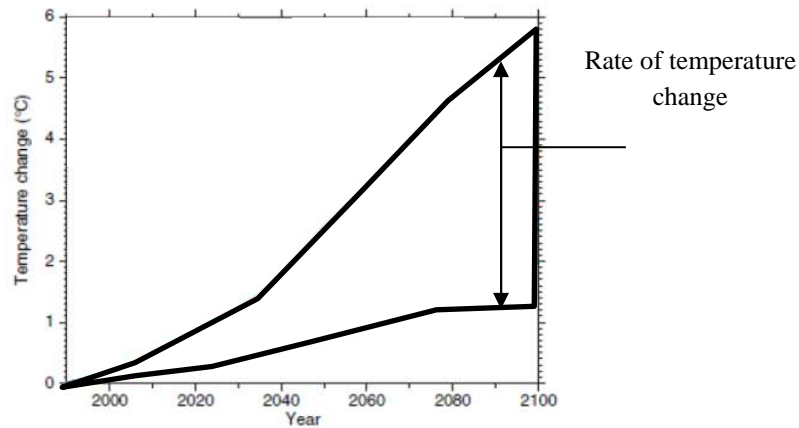

Diagram 4: Global climate in the 21st century (Ottmar, 2012)

The energy balance of the climate system has been altered by changes in atmospheric concentration of greenhouse gases (GHGs), solar radiation, land cover and aerosols. Global greenhouse gas emissions rose about 70% and carbon dioxide (CO₂) increased by nearly 80% with an annual increase of 1.7% for residential buildings from 1970 to 2004. In addition, Special Report on Emissions Scenarios (SRES) estimated an increase of 25% - 90% carbon dioxide in global greenhouse gas emissions from 2000 to 2030.

2.4 Energy Use and Shortage Problem

The world is facing a big challenge because of the shortage of energy, which is one of the impacts of economic development. By economic development, the need of electrical power which depends on the fossil fuels increases. Therefore, the expectancy of fossil fuel consumption will rise in the future, and this will cause upsurge in the price of energy sources such as oil (Diagram 5).

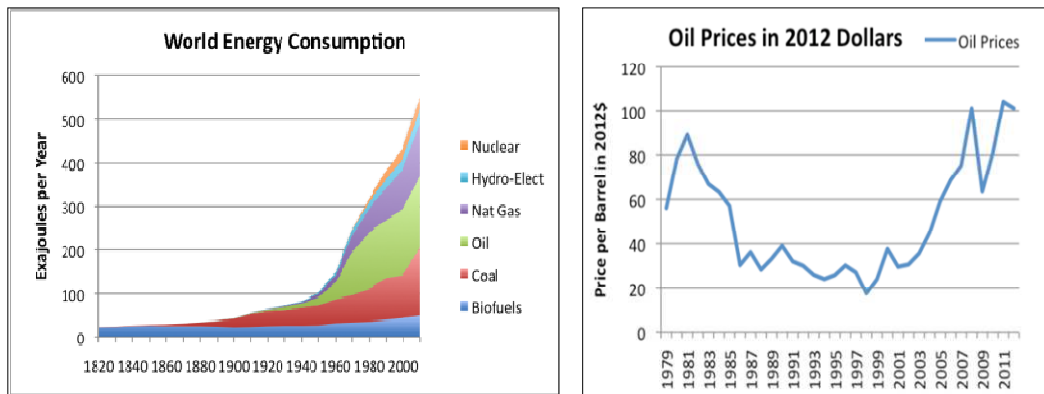

Diagram 5: Left, worldwide energy consumption; Right, oil prices in 2012 in dollars (Tverberg, 2013)

According to the literature, nearly 86% of the energy used in the world is supplied from fossil fuel sources, such as natural gas, coal and petroleum (Tverberg, 2013). Stated by Oettinger (2010), the fossil fuel reserves can probably provide energy for the next one or two centuries, hence, more than one third of the European Union (EU) electricity power generation capacity will be lost until 2020 because of the limited life time of its installations, which depend on low-carbon energy sources (mainly hydropower and nuclear power).

In addition, population growth is another factor leading to energy shortage. Diagram 6 shows the per-capita energy usage between 2000 and 2010 in the last decade, which is increasing rapidly (Tverberg, 2013).

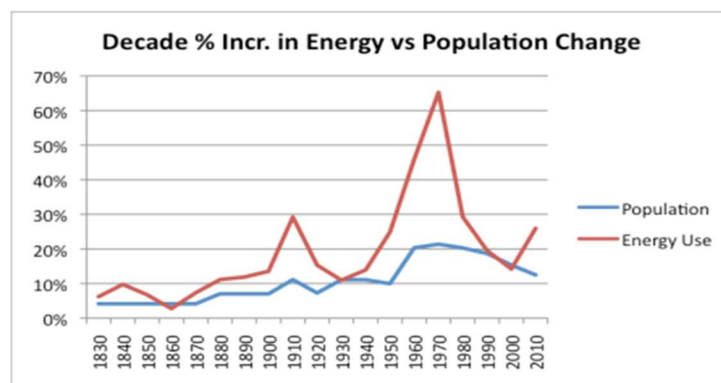

Diagram 6: The increase of energy use compared to population growth (Tverberg, 2013)

2.5 The Use of Renewable Energy Sources

Power generated from renewable energy sources can be labeled as solar, wind, biomass and geothermal energy. These natural resources can generate energy through photovoltaic (solar cell) arrays, wind-powered turbines and other byproducts, including municipal solid waste, digester gas and landfill gas. The essence of using renewable energy world-wide is very significant not only for its effects on sustainable economic growth, but also for its preventing global climate change (Kemal, 2012).

Nowadays, there is a huge increase in the share of renewable energy generators worldwide; for example, in European Union countries, the usage of renewable energy has risen 10% in the total final energy consumption in 2009, and at the same time, the European union's renewable energy sources, especially wind and solar, have been accounted for 62% of recently installed electricity generation capacity (Oettinger, 2010). Eurostat (2011) estimated that the share of renewable energy sources will be increased in the total energy consumption around 20%.

2.6 Building Standards (Codes) and Regulations

According to the International Energy Agency (2007), building energy standards (codes) are verified cost effective means for improving energy efficiency in new buildings. These standards differ along countries in some respects; such as specific requirements, coverage level, enforcement system, and compliance attaining mean (IEA, 2007).

Specific Requirements: Specific energy requirements for new buildings vary in different countries. It is difficult to compare energy requirements for the building envelope due to the various climate conditions and construction practices countries. Even in the similar climate zones such as India, Japan and the United States, the importance of specific requirements for building-components is different. For example India has been particularly stringent for walls, while Japan has been particularly stringent for windows, and the United States have particular stringent-requirements for roofs of single-family homes (IEA, 2008).

Coverage Level: Building energy standards at least cover insulation, solar and thermal properties of the building-envelope, which includes windows, roofs, walls and other areas. Mainly, the standards cover heating, air conditioning and ventilation, hot-water supply systems, electrical power, and lighting. Some standards cover extra issues such as the use of renewable energy, natural ventilation, and building maintenance (Evans, 2009).

Means of Attaining Compliance: Building energy standards typically provide property owners with some flexibility in meeting the energy-efficiency requirements. This is noteworthy because the code can be more rigid, not impinging too severely on the ability of property holders, at the same time, to adapt the buildings to their needs (Evans, 2009).

Enforcement Systems: Building energy standards, although are effective, but are not mandatory in all the countries; for example, India and Japan have a voluntary standard system while Canada, Australia and the United States all adopt building

standards at the local level. On the other hand, China has completely mandatory national codes.

Some significant issues concerning enforcement and its associated effects on the energy usage standards include compliance design and construction stages: in which ways and by whom buildings are inspected. Disadvantages of compliance, information and training in these standards are such as compliance software, equipment, inspection checklists, and material testing and ratings (IEA, 2007).

2.7 The Importance of Building Energy Standards

Building energy standards are very important in improving energy efficiency in new buildings. The United States (USA) saves more than one billion dollar yearly in energy costs by using these energy standards; and the figure is on the rise.

Similarly, Diagram 7 shows highlights the amount of energy decrease through the use of building code in different European countries. The average energy consumption per dwelling has reduced by using building energy standards. The decline is around 50% for Germany and Slovakia, 35% for France and Netherlands, 27% for Denmark, 16% for Sweden and 11% for Ireland (Mure, 2011).

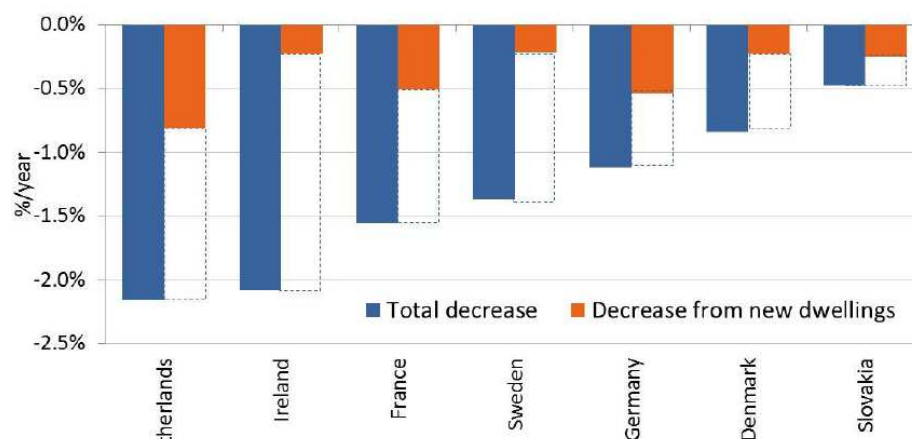

Diagram 7: Effects of using building standards (Mure, 2011)

2.8 The European Passive House

There are many different types of energy efficient houses, for example “low-energy”, “zero-energy”, “energy-plus” houses, “active houses” and “passive houses, and many others. The concept of “Passive House” was widely accepted as an essential cause for enhancing energy efficiency in European buildings.

Henceforth, more than 25.000 passive house dwellings have been built worldwide.

The passive house originates from the idea of Bo Adamson and Wolfgang Feist. (PHI, 2012).

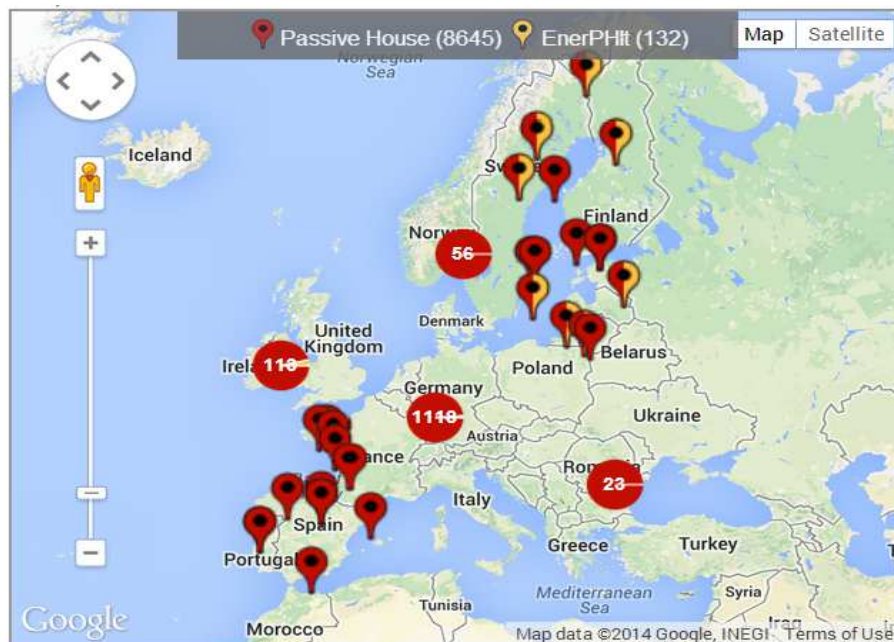

Figure 1: Map of Certified Passive House Buildings in Europe (http://www.passivehouse-international.org/index.php?page_id=288)

2.9 Definition of a European Passive House

A passive house or "Passivhaus" is one of the energy efficient classifications for new constructions to reduce the amount of energy consumption in residential buildings.

Passive house has been defined by German Passive House Institute as “a building, for which thermal comfort (ISO 7730) can be achieved solely by post-heating or

post-cooling of the fresh air mass, which is required to fulfill sufficient indoor air quality conditions (DIN 1946) - without a need for re-circulated air” (Feist, 2006).

At first, in central Europe, the concept of passive house had been designed for residential buildings. Though now, the concept can be implemented in all types of buildings, such as for schools, offices, and etc. and is suitable anywhere in the world. In early times, although there were many such passive houses, and they had serious problems; for example, the performances of windows were not satisfying or they were covered with temporary insulation and the air tightness was not permanent (Feist, 2006a). The standard for passive house was established in May 1988, by Prof. Bo Adamson and Wolfgang Feist. The first European passive house under those standards was built in Darmstadt, Germany in 1990, showing a reduction of 90% per year in space heating load compared to standard buildings at that time (Elswijk, 2008).

Passive house is the world’s leading standard in building energy efficient constructions compared to conventional standards for total energy saving, the use of passive house standards would be more than 75%. Passive houses are cost efficient, high quality, healthy and sustainable constructions (Wilson, 2013).

Therefore, the passive house is the main method for improving the efficiency of energy in houses; and the aim of passive houses is to create a comfortable house without excessive energy demand.

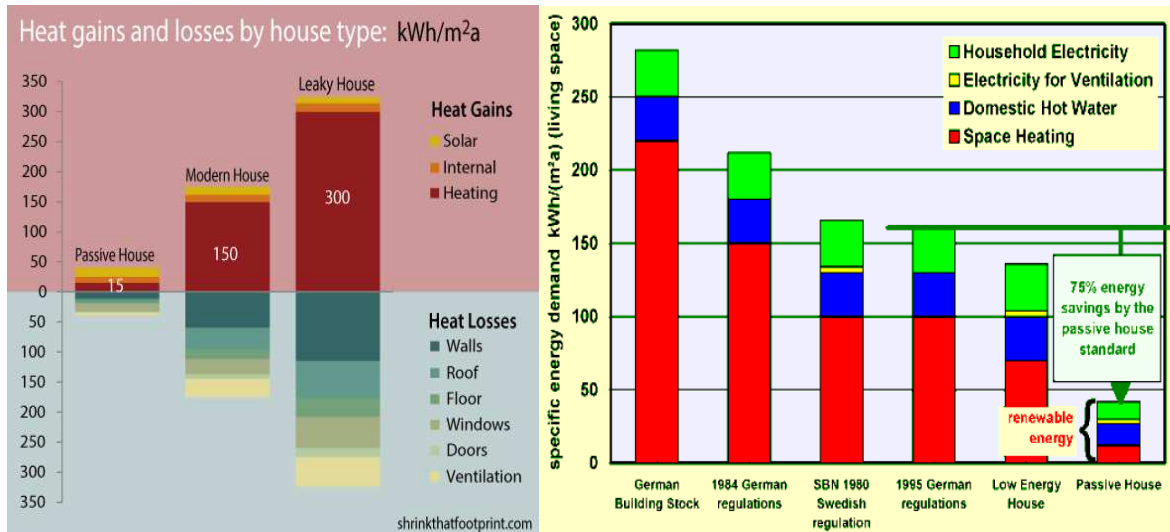

Diagram 8: Comparison of energy consumption in different buildings (Wilson, 2013)

Originally, passive house standard was established or developed for cold climates of central and northern Europe. Hence, to develop a passive house concept in warmer climates in southern Europe, in countries such as Spain, Italy, Portugal, Malta and Greece, new design guidelines were needed. As a result, Mediterranean passive houses were settled in design guidelines and developed within a context of passive-on project. (Passive-On, 2007a)

Passive-on is one of the projects sponsored by Intelligent Energy for Europe (SAVE program): The European Community on energy efficiency in buildings. Partners in the project are public and private research institutes from Germany, Spain, Portugal, France, UK and Italy. Passive-on project is aimed to offer guidelines, specifically in the way of applying passive house design methods for buildings located in warmer regions, especially southern Europe (Passive-On, 2007a).

2.10 Passive House Standards

Passive house standard is necessary in building construction, and the standard can be met by using some construction technologies, methods and design strategies, which can be used in any type of building. Passive house standard, although varies in

different countries, but is typical in definition which is given by the "Passive House Institute".

Passive house standard is a particular construction standard for making buildings comfortable and in good conditions for all seasons, by limiting or without traditional active cooling and space heating approaches. Typically this includes optimized insulation levels with minimal thermal bridges, very low air-leakage through the building, utilization of passive solar and internal gains and good indoor air quality maintained by a mechanical ventilation system with highly efficient heat recovery. Renewable energy sources are used as much as possible to meet the resulting energy demand (PHI, 2012).

The basic criterions and features of this standard, mainly covered by German passive house standard, for central European countries are:

- Annual energy demand for space heating should become less than 15 kWh/m²
- Having a super insulating for the building envelope without thermal bridge, low wall, floor U-values and roof about 0.15 W/m²K.
- Passive use of solar energy is very essential in the passive house design; decreasing heat loss and maximizing solar gains can be achieved by special orientation, shape and suitable shading in a building.
- Proper airtight in the building envelope should decrease ventilation heat loss to become less than 0.6 each -1 at 50Pa.
- Using heat pumps and solar collectors to get energy for heating the water supply.
- Openings (glazing and frames) should have U-factors less than 0.80 W/m²K, with coefficients of solar heat gain around 50%.

- Using renewable energy sources to decrease the demand for primary energy to become less than 120 kWh/m² yearly, while reducing greenhouse gas.
- In winter, the room temperatures should be kept over 20°C, using the above mentioned criterion to satisfy the thermal comfort of the residents (PHI, 2008).

The following table shows the criterions of passive house standard (PHI, 2008).

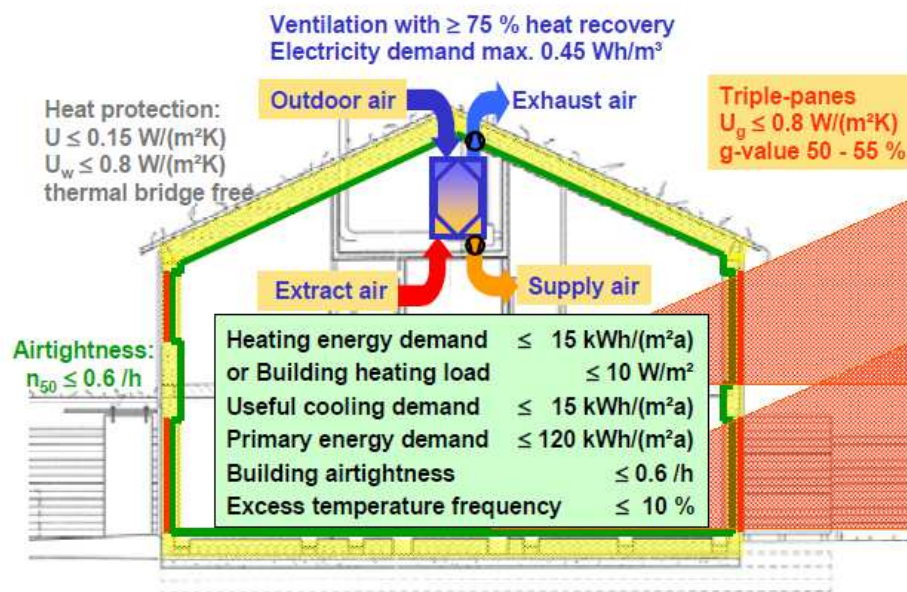

Figure 2: Passive House criterions (PHI, Passive House requirements, 2012)

Table 1: Criterions for passive house (PHI, 2008)

Main Factor		Factor	Standard
Energy	Heating energy requirement	Annual space heating requirement	≤ 15kWh/m ² a
		Heating power (constant heating load)	≤ 10W/m ²
		Heating power for one family house	≤ 1.600W
		Heating energy consumption for one family house	≤ 2.000Wh/a (200 l Oil)
	Energy requirement	Total energy requirement (for space heating, domestic hot water and household appliances)	≤ 120kWh/m ² a
Window	U-factor	U-factor of glazing	0.6 ≤ U _g ≤ 0.8W/m ² K

		U-factor of window frame	$0.5 \leq U_f \leq 0.9 \text{ W/m}^2\text{K}$
		U-factor of windows (glazing and frames, combined)	$U_w \leq 0.80 \text{ W/m}^2\text{K}$
	Solar coefficient	Solar heat gain coefficient of windows	$50\% \leq g$
Door	U-factor	U-factor of external doors	$U_d \leq 0.8 \text{ W/m}^2\text{C}^\circ$
Opaque thermal envelope	Insulation	U-factor of all opaque components of the thermal envelope	$U \leq 0.15 \text{ W/m}^2\text{K}$
		The thickness of insulation material	25 - 40cm
		Thermal bridge heat loss coefficient	$\leq 0.01 \text{ W/mK}$
	Air change	Air change rate at 50 Pa	$n_{50} \leq 0,6 / \text{h}$
Ventilation system	Grade	Heat recovery grade (efficiency) of ventilation system	$75\% \leq$
	Electricity consumption	Electricity consumption of ventilation system	$\leq 0.4 \text{ W/m}^3$

In addition to the above mentioned criteria, passive house institution has added some extra standards for passive houses in warm European climates, especially southern Europe, as follows:

- Cooling: Annual energy load for space cooling should be less than 15 kWh/m^2
- Summer thermal-comfort: Room temperatures should stay within the comfort range as defined in EN 15251. Moreover, room temperatures should be kept less than 26°C if an active-cooling system is the main cooling device.
- Air-tightness: In the case of proper thermal comfort and decent indoor air quality being achieved by a mechanical ventilation system, air leakage from unsealed joints should also be less than 0.6 ach-1 at 50Pa (Passive-On, 2007b).

2.11 Energy Efficiency Requirements for Passive House

2.10.1 Super Insulation









Proper insulation is the main principle in passive houses which reduces heat loss. Therefore, a passive house does not need an active heating in cold winters and the internal surfaces' temperatures are kept nearly or equal to the indoor air temperature. This helps to avoid damages caused by the humidity of indoor air, leading to have a decent comfort quality indoors. There are various types of insulation materials with different properties. Usually, the main expressive property used for insulations is U-value. Passive house insulation thickness differs by differences in climates, building structures and insulation material types (Table 2). From environmental protection (conservation) viewpoint, insulation material must be green, i.e. recyclable, and do not contain harmful substances that cause pollution (PHI, 2006 c).

Table 2: Insulation thickness and windows U-value for different passive houses in different locations (Golunovs, 2009)

	Mannheim	Kiruna	Helsinki	Almaty	Moscow
External wall insulation	15 cm	60 cm	50 cm	50 cm	50 cm
Slab to the ground insulation	30 cm	100cm	60 cm	60 cm	80 cm
Roof insulation	20 cm	40 cm	40 cm	40 cm	40 cm
U-value of window glazing (W/m ² K)	0,72	0,36	0,72	0,72	0,72
U-value of window frame (W/m ² K)	0,7	0,35	0,49	0,7	0,7

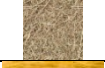
Feist (2006 b) has presented an interesting data regarding the thermal insulation of passive houses. Table 3 shows “the thickness needed of an exterior construction, if that is only built from the given material, to meet a typical passive house U-value of 0, 13 W/ (m²K)” (Feist, 2006 b).

Table 3: Building material thickness with U-value 0.13W/m²K (Feist, 2006 b)

Nr	Material	Thermal conductivity	Thickness to meet U=0.13 W/(m ² K)	
		W/mK	m	
1	Concrete B50	2.1	15.8 m	
2	Solid brick	0.8	6.02 m	
3	Hollow brick	0.4	3.01 m	
4	Wood	0.13	0.98 m	
5	Porous bricks, porous concr.	0.11	0.83 m	
6	Straw	0.055	0.41 m	
7	Typical insulation material (Mineral wool, Polystyrene, Cellulose)	0.04	0.3 m	
8	Highly insulation material (Heat conductivity 0.025 W/mK)	0.025	0.188 m	
9	Nonporous "super insulation" (normal pressure)	0.015	0.113 m	
10	Vacuum insulation (silica)	0.008	0.06 m	
11	Vacuum insulation (high vacuum)	0.002	0.015 m	

Vacuum Insulation Panels (VIPs) offer higher performance, when it's compared with other insulation materials such as fiberglass, polyurethane and expanded polystyrene (EPS).



Figure 3: Thickness comparison between several insulation-materials. (<http://www.sealedairspecialtymaterials.com>)

Because of the high-costs and thermal bridge problems caused by problematic connections, the Vacuum Insulation Panels (VIPs) are not preferred. Mainly, renewable thermal insulation materials are used for superinsulation without regarding to insulation thickness.

2.10.2 Thermal Bridges

Thermal bridge avoidance is very important in passive house standards, so that heat loss would be minimized and better thermal insulation efficiency would be gained.

According to PHI (2006b), “the larger heat transport occurs where the thermal resistance is lowest. Very often heat will ‘short circuit’ through an element, which has a much higher thermal conductivity than the surrounding material”. Experts call this case a “thermal bridge”. Thermal bridge has effects on decreasing interior surface temperatures and considerably increasing heat loss and gain based on the seasonal climate. Therefore, it causes the structure to gain heat in a hot climate, and that is why thermal bridges should be avoided.

Thermal bridge coefficient (Ψ) is a pointer to show the additional heat loss of a thermal bridge. If it is less than 0.01 W/Mk, then the building envelope (detail) is called “Thermal Bridge Free.”

PHI (2006b) mentioned that thermal bridge can be avoided by the junction being carefully designed between the wall and window or door, floor and wall, or roof and wall. Heat loss can be reduced through avoiding thermal bridging in a way, that insulation envelope should not be cut and should be placed at the end of building components; the connection of insulation layer should be overlapped and the edges should be selected with obtuse angles. Figure 4 and 5 show the design method for avoiding thermal bridges.

With a single-leaf external wall and a cellar floor or sole plate insulated on its upper or under side

With an external cavity wall and a cellar floor or slab to the ground insulated both on its upper and under side

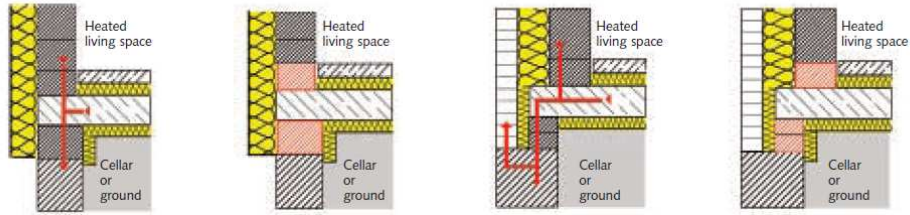

Thermal bridges between cellar floors or base slab and internal walls

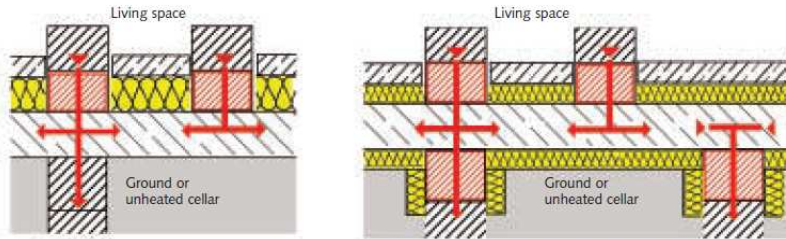

Here, the same applies as shown above for the external walls.

Thermal bridges between stair flights and thermally separating walls or base slab

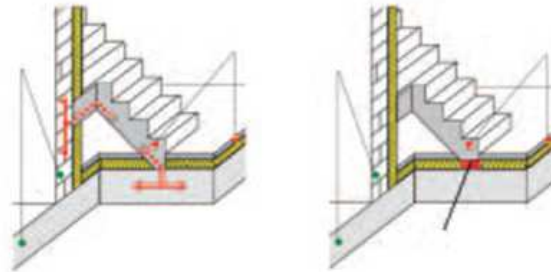

Figure 4: Thermal bridge avoidance in passive house (ISOVER, 2008)

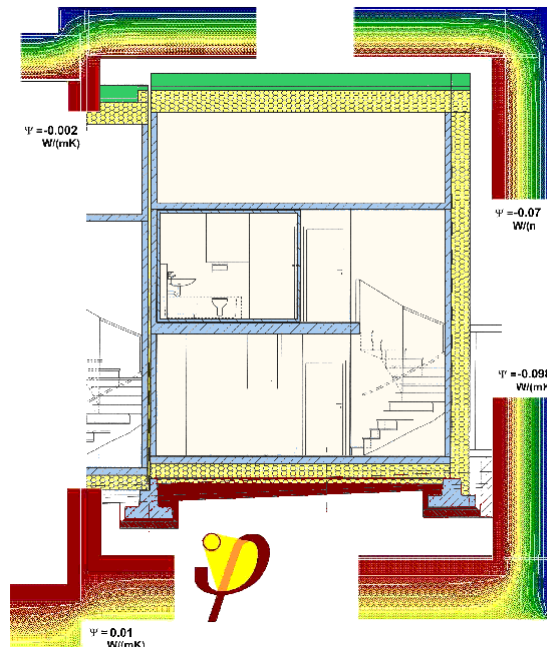

Figure 5: Thermal bridge section in a passive house (PHI, 2006b)

2.10.3 Airtight Construction

The house can lose its heat or coolness energy, depending on the season, by air penetration through the building envelope via windows, walls, floor, external doors, roof, or envelope component's junctions. Therefore, external envelope of the passive house must be airtight to achieve energy efficiency by avoiding heat loss and mold or moisture, reducing sound transmission, and improving the air quality (Figure 6) (ISOVER, 2008).

Generally insulation materials are not airtight (except from foam glass), and also well insulated construction is not certainly airtight. Since some insulating materials, such as glass wool or mineral, have excellent insulation properties but are not airtight, air can easily pass through them. Consequently, airtight envelope should be separately designed and built (PHI, 2006 d).

An inside plastering continuation is sufficient for masonry construction and wood composite boards can be used in the majority of timber constructions. Hence, airtight envelope should be continuous without interruptions, especially at joints (ISOVER, 2008). For a high quality building envelope, both air tightness and insulation are essential characteristics.

“Further, achieving air tightness should not be mistaken with the function of ‘vapor barrier’. Conventional room plastering (gypsum or lime plaster, cement plaster or reinforced clay plaster) is sufficiently airtight, but allows vapor diffusion”. (PHI, 2006d)

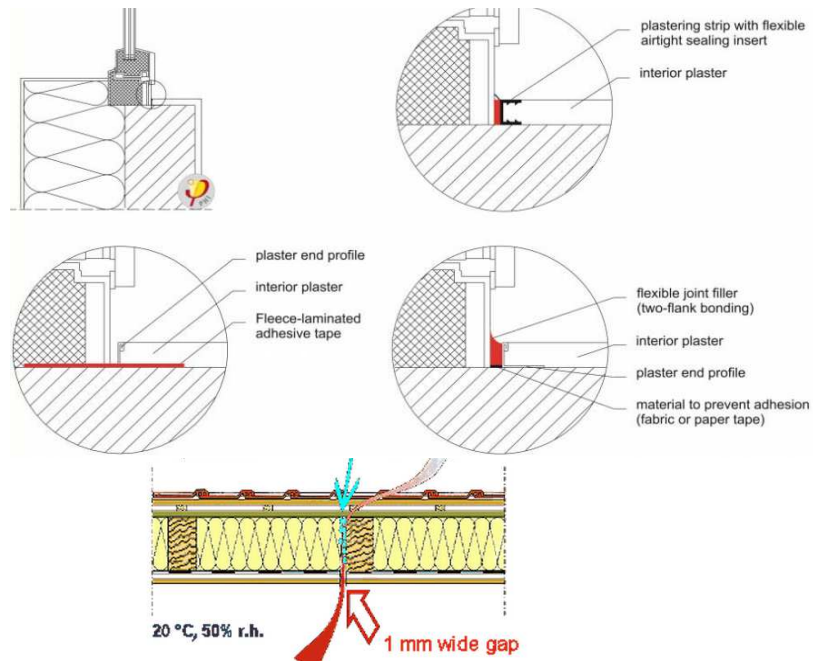

Figure 6: How to avoid heat loss and mold or moisture in passive houses (PHI, 2006 d)

Air tightness of a passive house should be measured after building by using “blower door test” (Figure 7). Air change rate of the passive house at a pressure of 50 Pa must be less than or equal to $n_{50}=0.6$ ac/h, and for hot countries it should be less than 1 area changing per hour (PHI, 2006d).



Figure 7: Blower door test (ISOVER, 2008)

2.10.4 Windows and Doors

Passive houses get use of highly efficient windows. The U-factor of the glazing and frame must be less than or equal to $0.8\text{W/m}^2\text{K}$ ($U_w \leq 0.80\text{W/m}^2\text{K}$). Window U-value describes the heat loss taken place through the window frames and windows. In a building, first the quality of windows increases rapidly, then the other components. Japan has already developed vacuum windows with a U-value of $0.05\text{ W/m}^2\text{K}$ which is near to the mineral wool property of insulation (ISOVER, 2008).

The type of glazing and frames used in the building differs regarding the climate differences. Hence, these three essential factors should be considered (Figure 8) (PHI, 2006e):

1. Triple-glazing with two low-e coatings
2. Insulating “Warm Edge” – spacers
3. Super insulated frames, such as plastic or wooden frames, and components for air tight windows and thermal bridge free.

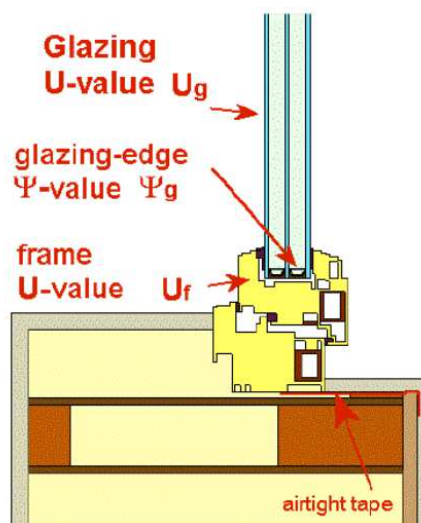

Figure 8: Passive house window (PHI, 2006 e)

According to PHI (2006 e), “in passive house, the main part of the windows is oriented to south in order to gain more solar heat. Top windows should be placed southern, bottom windows - northern, as this direction and position of the opening allow to have more solar gains during winter and to avoid them during the summer in order to prevent over heating”.

Referring to Janson (2010), proper dimensioned windows overhangs are very important in winter for penetration of solar radiation, while shading devices in summer should avoid overheating.

The same attention must be paid on the doors in a passive house. According to Janson (2010), the entry door with a 7cm thickness and U-value of 0.6 W/m²K used in an apartment in Värnamo, Oxtorget is estimated to save 200kWh per year.

2.10.5 Ventilation Systems

There are various types of ventilation systems that can be used in a passive house like natural ventilation systems (natural ventilation will be described in detail in the passive cooling section). Although natural ventilation strategy is suitable for hot climate, but a passive house needs good indoor air quality, which is impossible to achieve by using natural ventilation. Consequently, mechanical ventilation is needed to achieve proper indoor air quality. Hence, mechanical system is said to be an irreplaceable part of passive houses.

Heat Recovery Ventilator (HRV) and Energy Recovery Ventilator (ERV) are heat and air-exchanger ventilation systems. HRV provides fresh air and improves climate control, while saving energy by reducing cooling and heating requirements. ERV is very similar to HRV, but it transfers the humidity level of the exhaust-air to the

intake-air. Therefore, HRV is ideal for colder climate conditions, and it keeps the house supplied with a constant flow of fresh outdoor air, whereas ERV is used in hot climates and humid environments. ERV also recuperates the energy trapped in moisture, so it improves the overall recovery efficiency. ERV process is that, in humid climates and air-conditioned houses, when inside humidity is less than outside, ERV limits the amount of moisture coming into the house. In dry climates and humidified houses, when the humidity level is reversed, ERV limits the amount of moisture expelling from the house (Venmar, 2012).



Figure 9: HRV (Heat Recovery Ventilator)

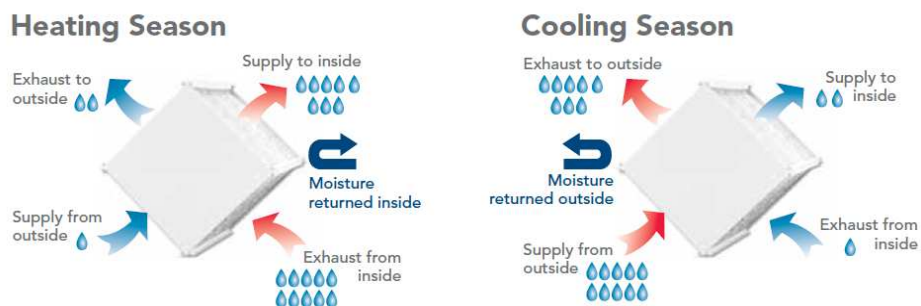

Figure 10: Energy Recovery Ventilator (ERV) (Venmar, 2012)

A counter-flow heat exchanger works as follows: Warm air or extracted air (red) delivers heat to the plates and this air leaves the exchanger cooled as the exhausted air (orange). On the opposite side of the exchanger plates, fresh air (blue) flows in

separate channels and this air absorbs the heat and then it leaves the exchanger with a higher temperature as the supply air (green) (PHI, 2006 f).

In passive houses, heat recovery level in the ventilation system must be equal to or more than 75% and the electricity must be low (below 0.40 watt for cubic meter air-flow).

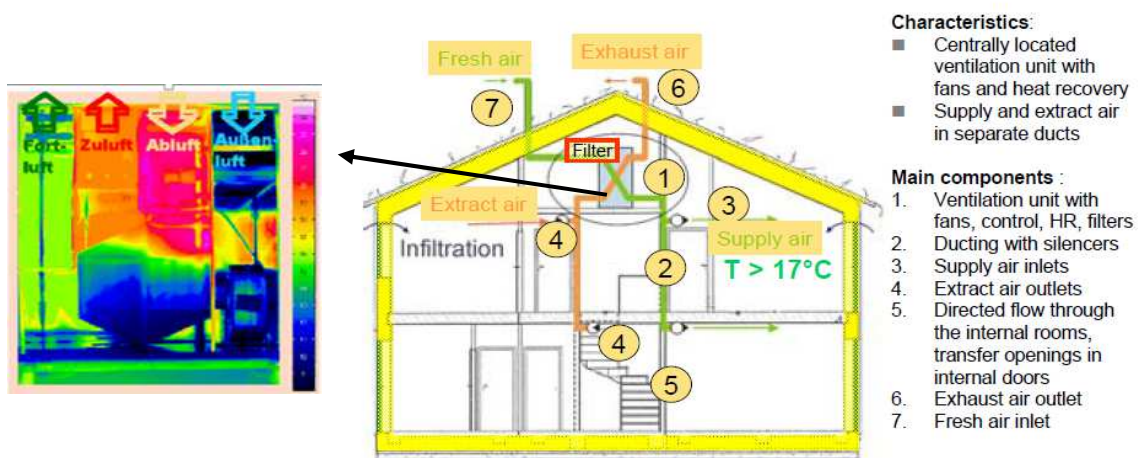

Figure 11: System concept for supply and extract air system with heat recovery (HRV) (PHI, 2006f)

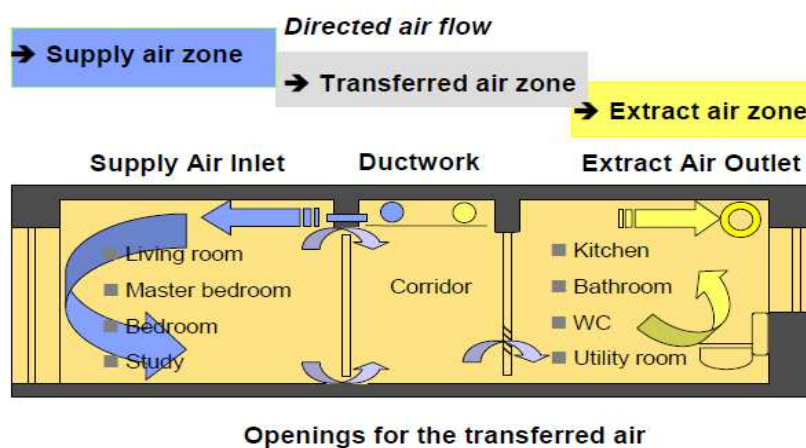

Figure 12: Cross-ventilation principle concept with supply and extract air (PHI, 2006f)

The aims of using a heat exchanger in passive houses are:

- 1- Removing air pollution, such as endotoxin, carbon dioxide and evaporation for spaces such as kitchen, bathroom, and toilet.
- 2- Supplying enough fresh air for occupants to live in, in spaces such as bedroom, living room, work room and study room.
- 3- Eliminating dust and controlling the incoming air, pollen, odors, and pollution, from entering the building.
- 4- Heat recovery and consequently energy saving, with the use of heat exchanger.

Earth buried ducts (Subsoil Heat Exchanger) is another opportunity to improve the efficiency of ventilation-systems. Ground, in summer time, has a lower temperature than the air outdoor, while in winter time, it has a higher temperature. Therefore, there is potential to use ground for precool fresh air in summer and preheat in winter, so to reduce the energy demand or need for cooling and heating (Figure 13). Passive houses need a high quality ventilation system and a high efficient heat-recovery (PHI, 2006 f).

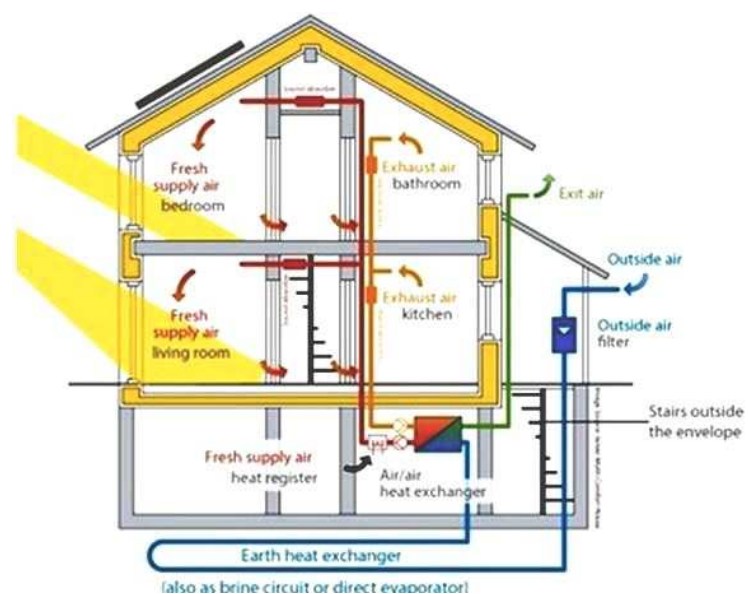

Figure 13: The diagram of ventilation system: “Stale air (pink) is removed permanently from the rooms with the highest air pollution. Fresh air (orange) is supplied to the living rooms” (PHI, 2006 f)

2.10.6 Economical Aspect

According to Janson (2010), “passive house concept is not an energy performance standard, but a concept to achieve high indoor thermal comfort conditions at low building costs.” According to this viewpoint, economic justification should be for all building elements and services, however, passive houses need extra investment to have a better construction quality by installing high-efficiency ventilation systems and building envelope. Schnieders and Hermelink (2006) investigated on 11 passive house projects in Germany, Sweden, Switzerland, France and Austria, with more than 100 residence units. Results show that the total extra costs for engineering system and construction investment is between 0 to 17% and 91 EUR/m² or 8% of total building cost for specific extra investment cost. Passive house can pay back the additional costs through its providing annual energy savings. It can save heat cost around 6.2 cent/kWh in average (Passive-On, 2007).

Investigating on central and south (Mediterranean) Europe passive houses, they figured out, that the extra investment costs range between 3% in Spain (Seville) to 9% in France. The payback period also ranges between four years in Spain (Granada) to 19 years in France and Germany. Passive house lifecycle cost over 20 years was lower than the cost for standard houses in Spain that can be achieved within 10 years. Generally, passive house payback period depends on rises in energy prices and technical economic issues (Table 4).

Table 4: Lifecycle cost (Passive-On, 2007)

		France	Germany	Italy	Spain Granada	Spain Seville	UK
Extra Capital Costs (€/m ²)		103	94	60	24,1	20,5	73
Extra Capital Costs (%)		9%	6,71%	5%	3,35%	2,85%	5,54%
Total Energy Savings (kWh/m ² /year)		55	75,0	86,0	65,5	37,6	39,7
Total Energy Savings (%)		45%	50,0%	65,4%	57,3%	40,7%	26,4%
Extra Costs per saved kWh/m ² /year		1,87	1,25	0,70	0,37	0,55	1,84
LCC 10 years€	Standard	143.731	184.716	193.817	101.828	98.385	108.337
	Passive	152.621	190.104	190.437	95.676	96.100	111.988
LCC 20 years€	Standard	160.343	204.942	221.148	117.928	108.689	117.875
	Passive	160.552	200.579	198.458	103.647	102.290	117.256
Cost-Benefit Ratio, 10 years		-0,72	-0,48	0,39	2,13	0,93	-0,65
Cost-Benefit Ratio, 20 years		0,02	0,39	2,63	4,94	2,60	0,11
Discounted Payback Period (years)		19.5	19	8	4	5	19

Feist (2007) made a comparison between passive house annual costs and the annual costs of low energy houses. Diagram 9 shows 40 years of total development costs (operating and fixed costs). When the family pays the fixed costs, after 30 years, they can enjoy the advantages of having a low energy bill by energy costs reductions they did.

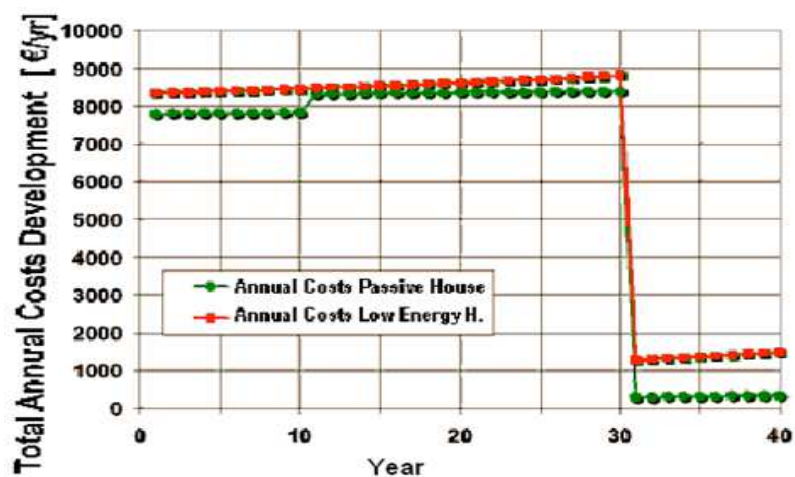

Diagram 9: Annual energy cost (Feist, 2007)

2.11 Passive Solar Systems in Passive House

2.11.1 Solar Heating

According to Bainbridge and Haggard (2011), building can be heated in three ways: Using of active solar energy which means solar technology, passive solar energy which means architectural planning and design, and at last hybrid system. In this regards, solar heating systems have four functions:

- **Collection:** Collection of the sun's heat, which falls upon the building's surfaces during winter days. The purpose is to allow sunlight into the house for heating of the interior space and if appropriate, to heat the storage mass.
- **Storage:** Storage of this heat for sunless or night periods. The purpose is to store the collected solar heat until it is needed by the occupants in the house.
- **Distribution:** Distribution of the stored heat throughout the house for human comfort and then to reduce energy consumption. Suitable heat distribution throughout the building can be achieved by a combination of convection and radiation.
- **Retention or Control:** Retention of the heat in the building by reducing or eliminating usual sources of heat loss.

According to the Bainbridge and Haggard (2011), passive solar system is “a system that stores, collects and redistributes solar energy without the use of fan, pumps, or complex controllers”. Hence, it is an architectural system, in which the material and

house elements such as roof, window and wall are used to store, release, collect and distribute heat in the house.

2.11.2 Use of Passive Solar Heating Systems in Passive House

Passive solar heating systems utilize the heat gained by the sun to compensate winter heating needs. There are three essential passive solar systems according to their heat gain: Direct, indirect and isolated (sunspace) gain. Each of these essential systems also has subsystems.

2.11.2.1 Direct Gain

It is the most common passive solar heating system. Simply, it consists south facing glazing and unoccupied space behind it, where the function of a solar heating system happens. Sunlight heats or warms the house by passing through the large south-facing window. When the solar energy penetrates through the window, it is absorbed by thermal mass: Floors, furniture, walls and solar energy reflected to ceilings. This reflection and absorption converts solar energy to heat. Direct gain systems utilize about 60-75% of the sun's energy striking the windows.

These systems have subsystems such as non-diffusing, diffusing, direct gain sunspace, clerestory and roof pond (Table 5) (Chiras, 2002).

Table 5: Direct gain types and classification (*Bainbridge & Haggard, 2011*) (*Roaf.S, 2001*)

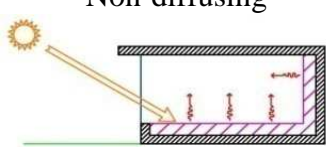
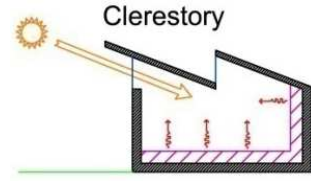
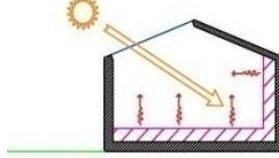
Direct gain		
South aperture	Shaded roof aperture	Roof aperture
<p>Non-diffusing</p> 	<p>Clerestory</p> 	<p>Direct gain roof</p> 

<p style="text-align: center;">Diffusing</p> 		
<p style="text-align: center;">Direct gain sunspace</p> 		

Table below compares the advantages and disadvantages of various direct gain systems:

Table 6: Direct gain advantages and disadvantages (Lapithis, 2004)

Advantages	Disadvantages
The large areas of south facing windows not only provide solar radiation for heating but also natural day lighting and visual conditions (outdoor views).	Large areas of south facing glass can cause glare problems in the daytime and privacy problems in the nighttime.
It provides direct heat to the space without the need to transfer energy from space or area to another.	The thermal mass used for heat storage should not be blocked by furnishings or covered by carpet
It can adjust the number and size of windows facing south, to suit the space for thermal mass. Clerestory windows can allow direct sunlight to fall on the back parts of the walls or floors using thermal mass.	It can overheat, if the thermal mass and windows are not balanced.
Direct gain is the simplest solar-heating system. It is relatively low in cost and easiest to build. The walls and floor can be used as storage mass and solar elements are incorporated into the living space.	South facing windows need summer- shading and a night time insulative covering in winter. Night-time insulation can be provided by shutters, exterior mounted panels, pop in panels, interior draperies, or other insulating window- treatments.
	Fabrics and furnishings exposed to ultra-violet radiation from the sunlight can change color or degrade.

2.11.2.2 Indirect Gain Passive Systems

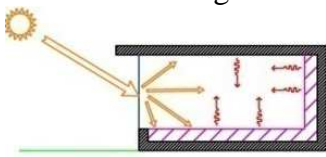
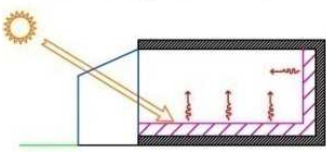
This system combines the storage, collecting and distribution functions, inside a part in the house envelope encompassing the living space. It utilizes a system to store and collect sunlight in order to be used later. Indirect gain systems contain a thermal mass placed between the living space and the sun, and they convert sunlight into heat and transfer it to the living space. Indirect gain passive systems utilize around 30-45% of the sun's energy striking the glass adjoining thermal-mass (Bainbridge & Haggard, 2011). Indirect gain systems have subsystems such as mass wall, trombe wall, water wall, remote storage wall, thermo-siphoning wall, simple U-tube collector, shaded storage wall, and roof pond (Table 7):

Table 7: Indirect gain types and classification (Bainbridge & Haggard, 2011)
(Roaf.S, 2001)

Indirect gain			
South aperture	Mass wall	Trombe wall	Water wall
	Remote storage wall	Themosiphoning wall	Simple U-tube collector
Shaded roof aperture	Shaded storage wall roof pond		
Roof aperture	Roof pond		

Table below shows the advantages and disadvantages of indirect gain systems:

Table 8: Indirect gain advantages and disadvantages (Lapithis, 2004)

Advantages	Disadvantages
The storage mass is located closer to the collection area or glass, which let for efficient collection of solar energy.	In the heating season, discomfort can be caused by overheated air from the trombe-wall in day time. Venting can decrease this effect.
The heat storage capacity and thickness of the thermal mass heats up progressively and distributes heat to the living area, when it is required.	The effective heating can be felt to a depth of about 1.5 times the height of the wall, because of the limited depth of natural convection air-currents and reduce the flow of heat from the warm sun-facing wall.
Unnecessary sun shine does not penetrate into the house. Ultra-violet degradation of fabrics, glare and privacy are not a problem.	The south facing natural daylight and view is lost. Therefore some trombe-walls have been designed with windows (glass) set into the wall to compensate in order to function effectively.
The wall and floor space of the living-area can be used more flexibly, while the storage mass is located close to the south facing glass.	In a smaller house, trombe-wall may be taken up too-much wall space.
The indoor-temperatures are more stable than in most other passive-solar systems.	At night, vented trombe-walls must be closed to prevent reverse-cycling of heated air
	Without sun-shine in the summer and winter days. Trombe-wall acts very poorly.

2.11.2.3 Isolated Gain Passive Systems

Isolated gain (sunspace or solarium) is the combination of direct and indirect gain systems. Solar collection happens in a separate part or area than heated spaces. In this space, large amount of the collected heat will be transferred into living spaces by convection through the thermal mass as well as by radiation in smaller amounts.

The advantage of these systems is that they can be used as extra living spaces as well. On the other hand, the disadvantage of isolated gain systems is, that it warms up very quickly; therefore, on hot summer days, the temperature can increase to be unbearable. In order to stabilize the temperature between the sunspace and the house, thermal mass in the forms of masonry-walls, water containers or floors can be used. At this time, movable-insulation helps in preventing excessive heat loss at night. Isolated gain systems have sub-systems such as sunspace, barra costantini, isolated wall collector, black attic, thermo-siphon rock bed, and thermo-siphon storage wall (Table 9) (Bainbridge & Haggard, 2011).

Table 9: Sunspace gain types and classification (Bainbridge & Haggard, 2011)
(Roaf.S, 2001)

Isolated Gain			
South aperture	<p>Sunspace</p> 	<p>Barra Costantini</p> 	<p>Isolated wall collector</p> 
Shaded roof aperture	<p>Black attic</p> 		
Remote aperture	<p>thermo-siphon rock bed</p> 	<p>thermo-siphon storage wall</p> 	

Table below shows the advantages and disadvantages of sunspace gain systems:

Table 10: Sunspace gain advantages and disadvantages (Lapithis, 2004)

Advantages	Disadvantages
Sunspaces are easily adaptable to existing home.	The sunspace glazed roof can be adequately cool at night time to cause condensation on its inside (internal surface).
Other passive solar systems can be easily combined with sunspaces.	It is relatively high in cost and the pay-back period of the investment in its building construction is longer compared with other methods (direct gain).
They buffer the main-spaces from extremes of exposure and thus reducing the possible temperature fluctuation, glare and the fading of furniture and fabrics, (which may result from extreme indoor- sunlight).	Growing plants lead to increased humidity and this may cause a discomfort and condensation in the house.
Sunspaces (winter gardens, conservatories, sun porches, and greenhouses) are intermediate usable spaces between the interior and the exterior of the house. They can constitute an additional living space in winter and in transitional seasons. With the provision of appropriate shading and ventilation in summer, these spaces may be pleasant environments throughout the year.	Sunspaces have large fluctuations in the temperature, this makes it unfit for living or growing-plants unless some control is used.
The inside climate of the house can be highly improved through the addition of a thermal (buffer) between the outside air and living space. A sun-space can run the full width and height of the house, reducing ventilation losses and fabric.	
Sunspace increases the possibility of collecting heat from a specific façade, through allowing a larger glass area than is desirable and practicable with direct-gain.	

2.11.3 Use of Passive Solar Cooling Systems in Passive Houses

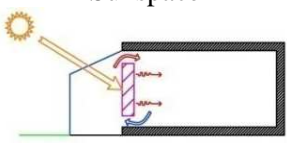
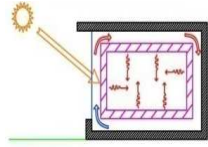
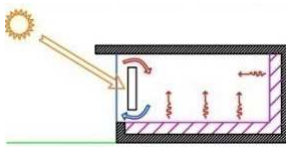
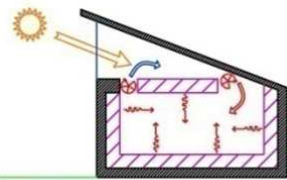
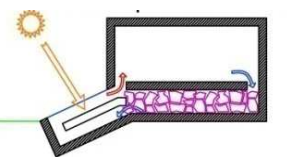
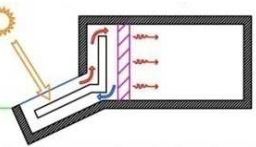
2.11.3.1 Natural Ventilation

Natural ventilation can be defined as using passive strategies to provide or supply outdoor air in the building's interior for cooling and ventilation. It depends on natural driving forces (climatic phenomena) such as wind direction, wind velocity and temperature differences between inside and outside (surrounding) of the building, to make the flow of fresh air through the building.

Natural ventilation happens through various architectural elements, connecting outside environments to inside, such as windows, vents, wind towers, holes, pipes (underground), and etc.

Natural ventilation has various cooling performances such as:

- Replacing inside hot air with outside cool air
- Decreasing air pollution and humidity
- Increasing evaporation, thus cooling the space (Etheridge, 2012)

Natural ventilation efficiency depends on the orientation of the opening, compiled with the direction of the wind, the size, location, form and type of the outlet and inlet opening, wind temperature and wind speed, depth of space, and etc.

According to Reardon (2010), the common methods of natural ventilation are:

- **Single sided ventilation:** In single sided ventilation, outdoor air enters the house through openings on a wall and leaves out through the same openings or another opening on the wall. This type is economical and proper for small internal spaces

and moderate climates. Usage of double opening is a way to increase the efficiency of this type.

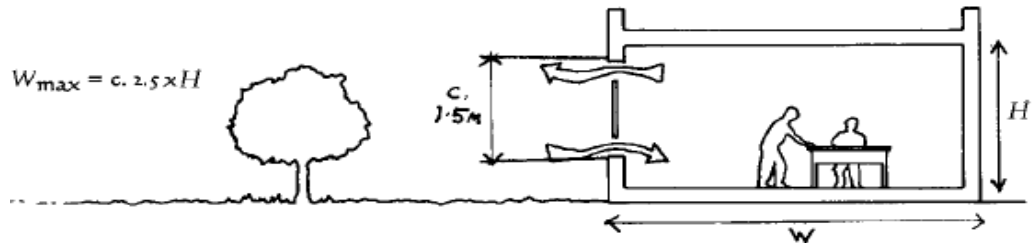

Figure 14: Single sided ventilation (Roaf.S, 2001)

- **Cross flow ventilation:** In cross flow ventilation, outdoor air (fresh air) comes inside the house from window openings on a wall while foul and hot air moves out of the house from window openings on other or opposite walls. This technique can provide more air flow rates and is effective in larger internal spaces.

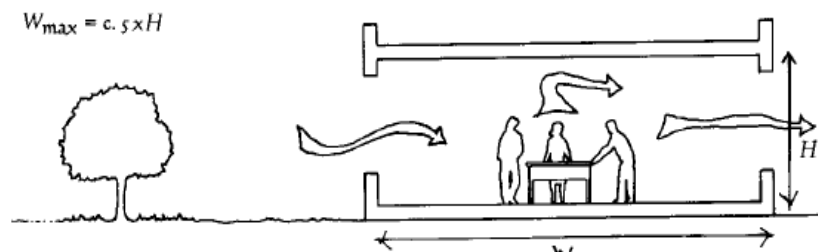

Figure 15: Cross flow ventilation (Roaf.S, 2001)

- **Stack ventilation:** In this technique, hot (warm) air flows naturally upward by stack effect and the house is vented through replacing hot air by fresh air entering from lower openings. Stack ventilation has developed by mixing stack and cross ventilation with using double façade.

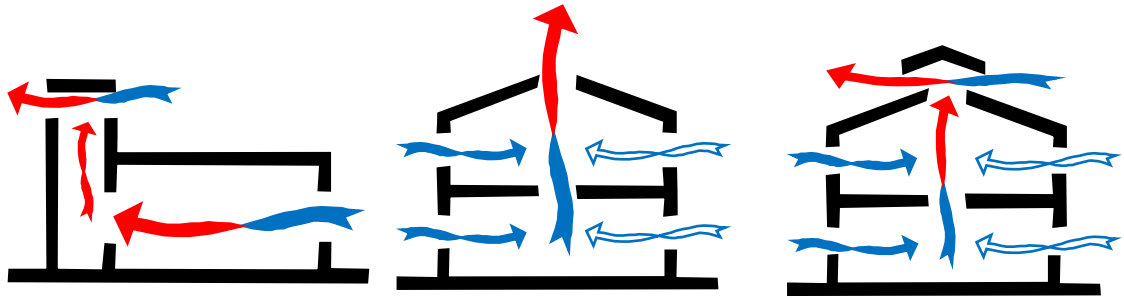

Figure 16: Stack ventilation (Brown, 2001)

2.11.3.2 Thermal Mass

Thermal mass is a material with high thermal capacity, which means the material absorbs and stores thermal energy. Concrete blocks and masonry walls are examples of thermal mass in the house. In fact, thermal mass works as a thermal battery, therefore during winter (cool) period, it stores the heat by absorbing the solar energy or heaters in daytime and releases it during night time, while in summer (hot) period thermal mass can be cooled through the night ventilation and being used to decrease cooling needs for the next day (Heiselberg, 2006).

In addition, the combination of night ventilation and thermal mass is suitable for climates with large fluctuations in ambient temperatures.



Figure 17: Left: Cooling with thermal mass; Right: Night cooling with high thermal mass (Brown, 2001)

2.11.3.3 Solar Control

Solar control means to prevent rooms or spaces from overheating in hot months, through blocking unwanted solar gains by shading devices such as overhangs, vine,

awnings, blinds, louver, vegetation and trees. At the same time, it will reduce the cooling energy consumption of a house. It will be explained more in detail in passive house design.

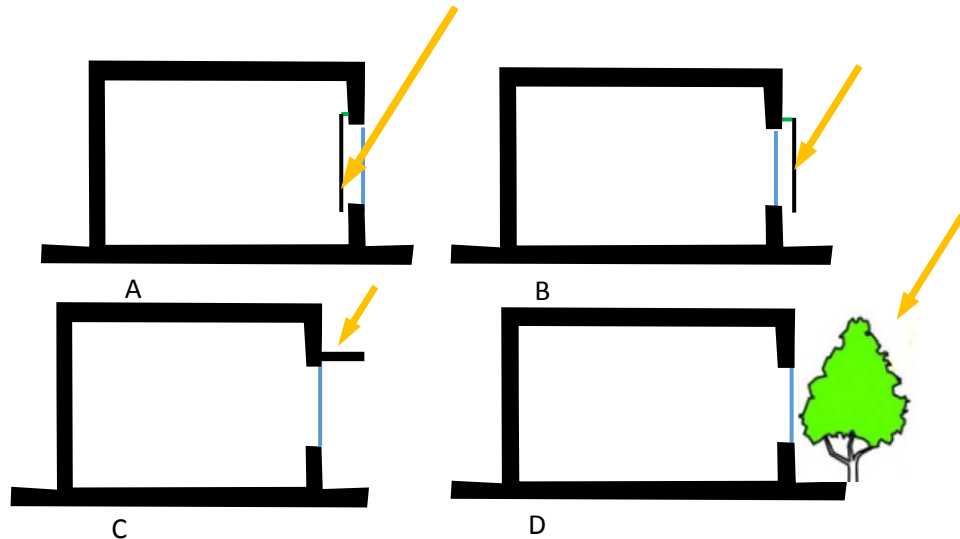

Figure 18: Solar Control: a- Interior venetian blind, b- Exterior venetian blind, c- Louvers and overhangs, d- Trees and vegetation. (Brown, 2001)

2.11.3.4 Evaporative Cooling

There are two types of evaporative cooling: Vegetation evaporating and evaporating water. The cooling ability of evaporating water has been used for centuries in the Middle East, in Southern Europe, and in Northern India to cool hot air. In fact, hot air is cooled by flowing-in contact with water, and transferring its heat to water, by evaporation.

Cooling efficiency of evaporative cooling system decreases in humid conditions, therefore, evaporative cooling is most efficient in dry climates. Evaporative cooling is used in the climates with humidity less than 70 % and in hot and dry regions, which have high evaporation capacity.

Furthermore, the combination of evaporative cooling (water ponds and vegetation) with natural ventilation can be used to increase air movement and hence cooling efficiency. To avoid over humidification and to achieve a desirable performance, evaporation rate and the amount of airflow through ventilation openings should be controlled (Passive-On, 2007).

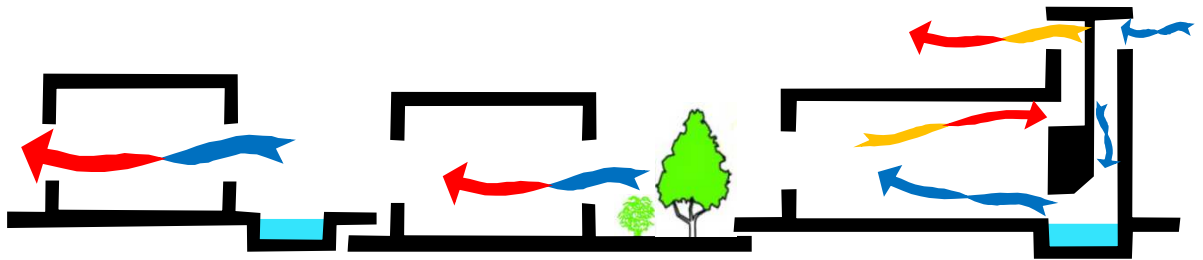

Figure 19: Evaporative cooling and natural ventilation
(www.builditsolar.com)

2.11.3.5 Indirect Evaporation

Indirect evaporation is suitable for hot and humid climates, because every gram of water extracts around 2550 J of heat from its environment and this principle can be used to provide cooling. Indirect evaporative can be reached through spraying water over the roof surface, a roof pond or a roof garden (Chenvidyakarn, 2007).

- **Roof pond:** It collects water on the building roof and lets it evaporate. Evaporation cools the building roof, and then helps as a heat sink for inside the building (interior).
- **Roof Spray:** When collecting water on the roof is not-possible for structural reasons, for example water can be sprayed on to the roof surface as an alternative to the roof-pond.

2.11.3.6 Green Roofs

Green roofs, in addition to having lots of ecological advantages, can be efficient in cooling down the surrounding building environment and preventing solar radiation (heat gain) by evaporation. Furthermore, they can act as an insulation material and decrease day and night roof temperature variations. They can be combined with evaporative cooling and natural ventilation for better cooling efficiency (Chenvidyakarn, 2007).

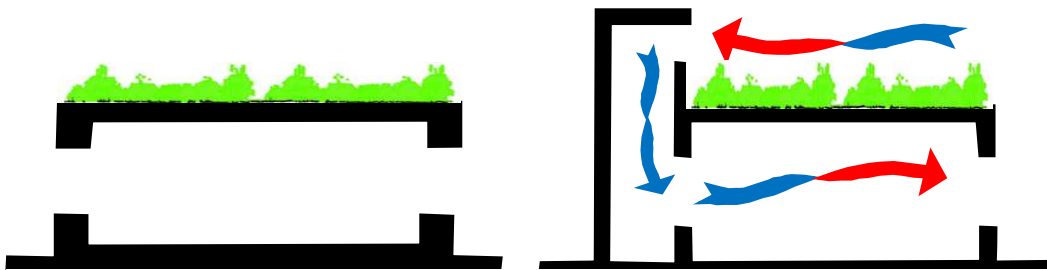

Figure 20: Left: Green roof; Right: Green roof, natural ventilation and evaporative cooling (www.builditsolar.com)

2.11.3.7 Earth Cooling

It is obvious that ground temperature is less than air temperature in hot periods. Therefore, when air naturally passes through the underground vents or pipes to enter the house, its temperature cools down. Then earth cooling has a high cooling efficiency through natural ventilation. (Reardon, 2010).

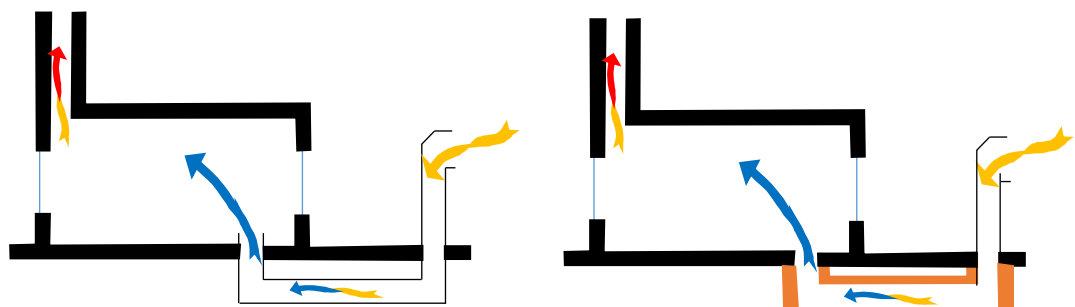

Figure 21: Earth cooling with evaporative cooling and natural ventilation (www.builditsolar.com)

2.11.3.8 Hybrid Cooling

Hybrid or mixed-mode ventilation is the mixture of natural and mechanical ventilation that natural ventilation should be used as much as possible to minimize the energy consumption (Reardon, 2010).

However, hybrid or mixed-mode ventilation systems offer the possibility of achieving energy savings in a greater number of buildings through combining natural ventilation systems with mechanical equipment.

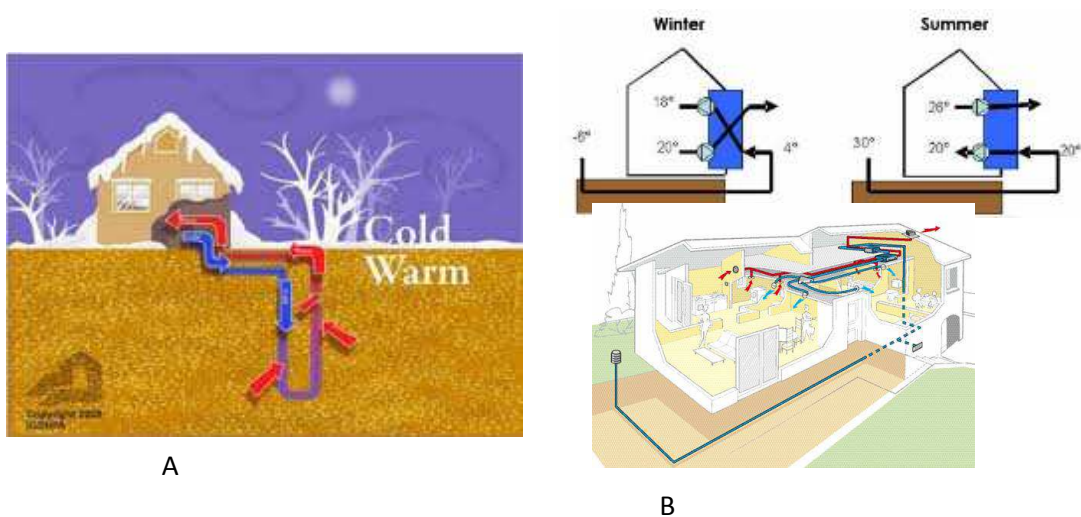

Figure 22: Hybrid cooling: A- Geothermal heat pump; B- Subsoil heat exchanger (earth cooling).(www.geothermalenergypump.com)

2.12 Use of the Passive Solar Design in Passive House

2.12.1 Typology/Shape (Compactness)

Building shape and typology extremely affect energy demand in buildings. They are important components in storage and absorption, and they let loose the heat during night and day. Therefore, typology or shape is a key factor in changing heating and cooling demands in the passive house buildings. Diagram 10 shows how the building classification, i.e. detached, semi-detached, terraced and apartment, affects

building heat loss. Compactness is a type of building typology which can be defined as “the ratio between the building volumes to an exterior wall area”; hence, higher level of compactness leads to reduce in cooling and heating energy demands and as a result, energy efficiency of the building (Ramzi, 2007).

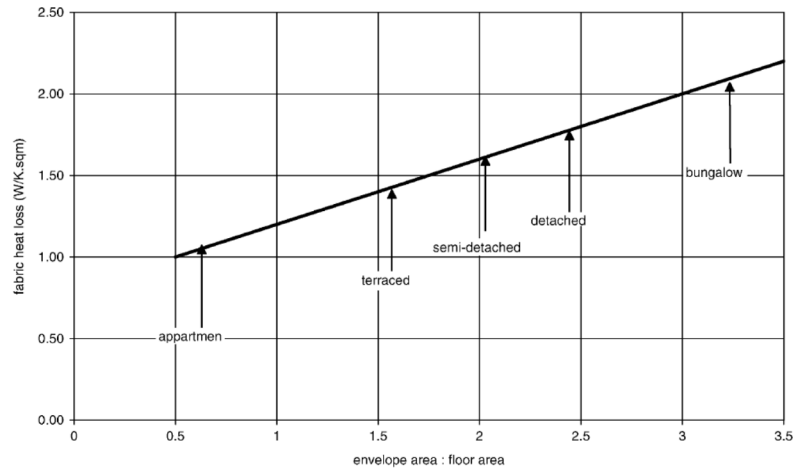

Diagram 10: Relationship between building form and heat loss
(Steemers, 2003)

The optimum form of building shape differs according to different climate regions. Therefore, the optimum form which has a consideration for maximum solar radiation gain in winter and minimum solar radiation gain in summer (Figure 23) (Gut, 1993).

Addition, width to length ratio and surface to volume ratio are other factors in achieving optimum building form. Karasu (2010), in his study has examined the effect of the buildings' lengths to width ratios in Turkey. The result shown in Diagram 11.

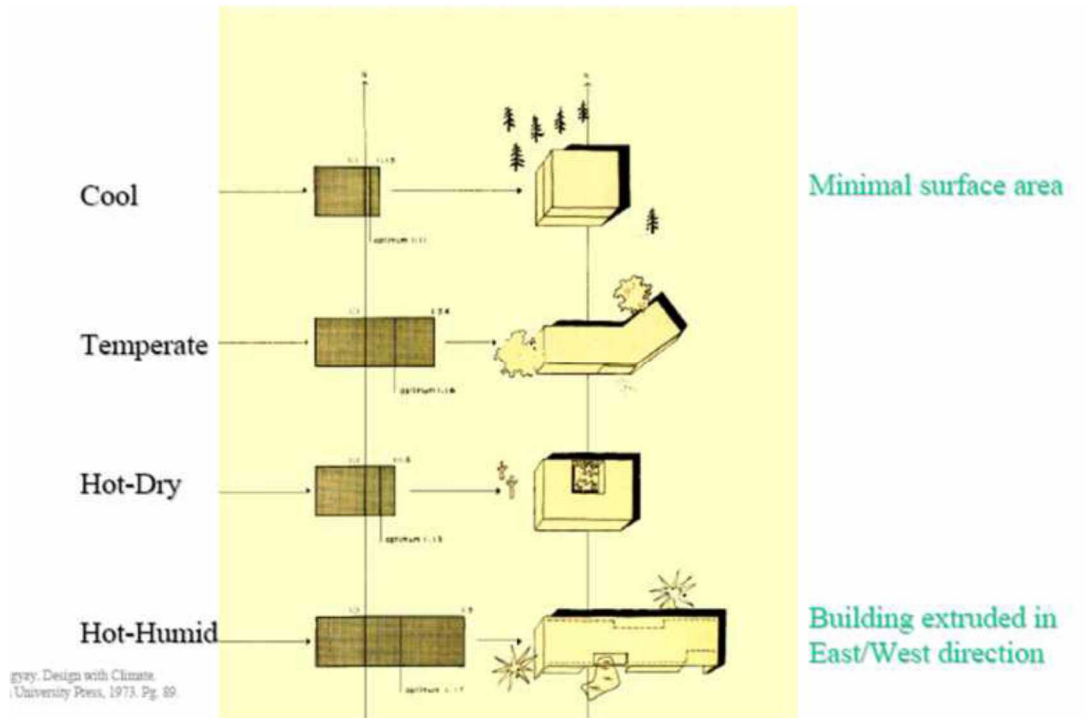

Figure 23 Building form for different climates (Al-khishali, 2010)

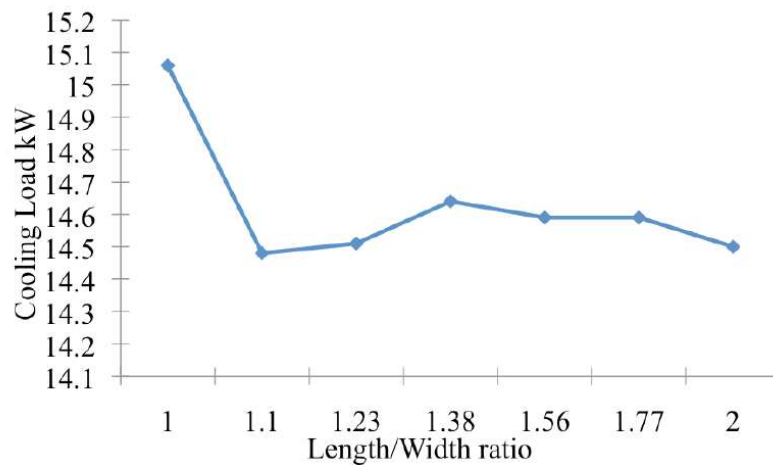

Diagram 11: Effect of the length/width ratio on cooling load (Karasu, 2010)

Table 11: Climate zone classification (Mathu, 2003)

Climatic Zone	Mean Monthly Maximum Temperature , C	Mean Monthly Relative Humidity, %
Cool	below 25	all values
Temperate	between 25-30	below 75
Hot dry	above 30	below 55
Hot humid	above 30 above 25	above 55 above 75

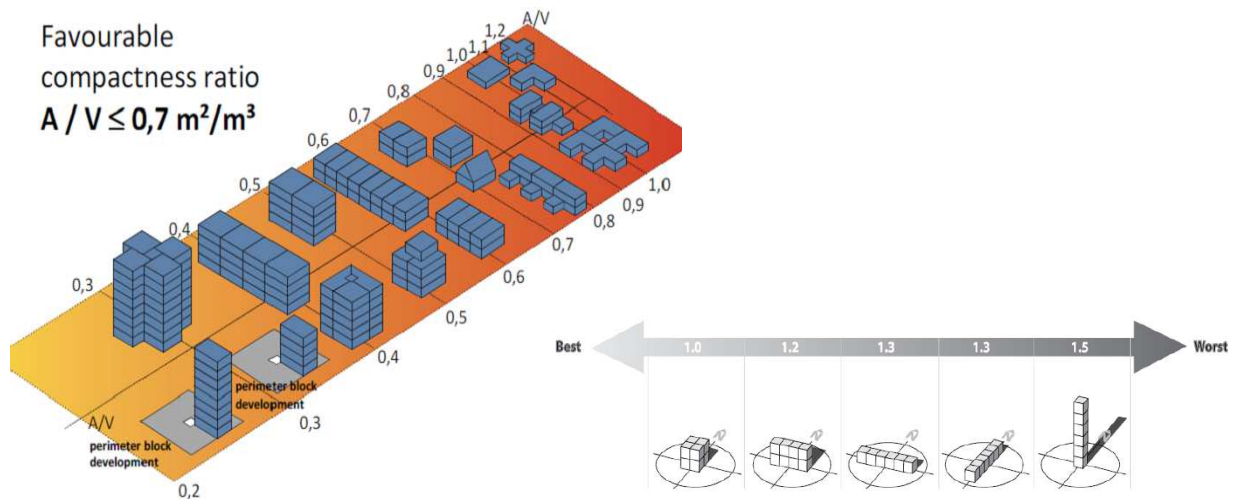

Figure 24: The effect of envelope to volume ratio on energy efficiency
 (http://localimpactdesign.ca/?page_id=48)

The following issues explain the important considerations in designing the form of passive houses in different climates:

- **Cold Climate:** Slope roofs are appropriate for rain protection and snow loads. A minimized well insulated building component which reduces heat loss is adequate (Rosenlund, 2000).
- **Temperate Climate:** Buildings are preferably compact because of incompatible climatic conditions; several approaches can be used depending on functional requirements and local topographical conditions (Gut et al. 1993). For example, one approach can be designing as an insulated and heated central winter unit, with open, shaded or glazed spaces around a courtyard for seasonal use (Rosenlund, 2000). Building form should be somehow allow sun in the coldest period and prevent it during the hottest period plus preventing wind and being wide surfaced (Biket, 2006).

- **Hot Dry Climate:** The building form and volume in hot dry climate should be compact, as well as being elongated to some extent along the east-west axis, for compact buildings gain less heat. An elongated form is best for winter conditions while a square form is better for summer conditions. Therefore, courtyard is preferable (Gut et al. 1993).
- **Hot Humid Climate:** The optimum form in a hot humid climate is the open elongated form to provide air movement, which is the only way to achieve thermal comfort. Inclined roofs with verandas create shade or wide overhangs and rain protection (Rosenlund, 2000). Considering wind, long formed buildings across the main wind direction is preferable (Gut et al. 1993).

2.12.2 Orientation

Wimmers (2009) has mentioned, that the best building orientation with respect to a site's geographical features and the earth's axis can improve passive gains and thus reduce the need for cooling systems or mechanical heating.

Al-Tamimi et al. (2010) have also claimed, that orientation is the main factor that can influence the building thermal comfort by reducing the direct solar radiation into the buildings through building envelopes, opaque walls or openings. For choosing a suitable building orientation many factors should be considered, such as the sun's movements according to latitude, the expected shading impact, time of the day and time of the year, and etc.

In fact, oriented buildings take benefit of prevailing wind and solar radiation. Karasu (2010) has mentioned, that the amount of solar radiations received by the building depends on the building's orientation, and the orientation, on the other hand, has an important influence on the cooling load. The main façades are preferably north-

south orientated, because in summer solar radiation penetrates into openings and façades are only slightly in these directions. However, in winter, there is a possibility of having solar penetration because the sun path is lower (Rosenlund, 2000).

Buildings' façade orientation is a main issue in passive design strategies. There are many factors in façade orientation that can affect the comfort level and energy consumption of the buildings, such as the window to wall area ratio, solar shading, window performance and position, and choice of exterior color.

Façades receive sun in various amounts in buildings. South façade will capture solar energy gains in winter when the path or angle of the sun is low, and then solar energy gain can be used for passive solar heating in winter. Conversely, in the west and east building façades, a window should be cautiously located to capture the second highest radiation intensities. It should be noted, that too much solar heat gain in the west direction can be also be mainly problematic, because the maximum solar radiation intensity coincides with the hottest part of the day (Wimmers, 2009).

The following issues explain the important considerations of choosing orientation in passive houses located in different climates:

- **Cold Climate:** Building orientation for solar access is essential, particularly in winter period. A building should be oriented to collect maximum amount of solar radiation to use it for warming the building, and also to avoid the prevailing cold winds. Therefore, the proper orientation would be facing south (Nayak, 2006).

- **Temperate Climate:** In temperate climate, a building's orientation of 18 degrees east from south provides a balance in heat dispersal. High building's orientation must be determined depending on the wind effect (Biket, 2006). In summer, building orientation must be arranged to benefit from summer winds, because usually the weather is humid and suitable cross ventilations should be used for cooling. Moreover, shelter must be protected from winter winds (Gut et al. 1993).
- **Hot Dry Climate:** Building orientation in accordance to the sun in hot dry climate is very significant. North-south orientation of the main façades is proper in this climate (Nayak, 2006). Buildings are best arranged in clusters for heat absorption: Protecting from east and west exposures and having shading opportunities. Generally, the optimum building orientation is north-south with a 25-degree to south-east direction. Orientation should allow maximum prevailing cool winds to provide cross ventilation in the living area (Gut et al. 1993).
- **Hot Humid Climate:** Building orientation in a hot humid climate should be in accordance with the prevailing winds. Particular care should be given to allow preferred winds to enter and avoid cold winds in cooler seasons (Nayak, 2006). Shading west and east façade in accordance to the sun orientation is difficult, because the sun level is low and a special device may be required, while north and south façade can be protected easily using overhanging roof. Wimmers (2009) have stated that "ideal orientation south-facing windows allow for winter heat while strategically placed deciduous trees and overhangs will shade the hot summer sun. Neighboring properties can affect solar access and wind pattern".

2.12.3 Building Indoor Arrangement in the Northern Hemisphere

Building indoor arrangement is very important for having energy efficiency. According to Wimmers (2009), indoor arrangement can become more energy efficient, if it is designed or planned according to prevailing wind direction and solar orientation, and he specified the possibility of energy saving through such planning. Gut et al (1993) have claimed, that the indoor arrangement of rooms depends on many factors such as room function, time of the day, and if they are in use. Designing considerations for some spaces in the house are:

- **Kitchens:** Kitchens should be placed in the building somehow to avoid overheating. Proper kitchen location is on the northern or eastern elevation or in a central space in the building.
- **Living Spaces:** Living or dining rooms are frequently used rooms in a residential building. Therefore, they must be situated on the southern elevation where they can be warmed by sunlight during the daytime. Proper living or dining room location is on south elevation.
- **Bedrooms:** In general, bedrooms require less heat. The location of the bedrooms can be based mainly on designer preferences and aesthetics, in addition to thermal comfort. Preferably, windows must be allowed for passive ventilation and kept to a minimum. Then, bedrooms are located according to comfort.
- **Mechanical Systems:** Plumbing and mechanical equipment must be grouped (be in close proximity to each other). This reduces heat loss or inefficiencies in piping due to needlessly long lines, and economizes the space devoted to mechanical uses. Therefore, bathrooms, laundry and kitchen must be located above or close to each other so to reduce build path by using short pipe runs (cold and hot water) and ventilation ducts.

2.12.4 Landscaping

Landscaping is very important for achieving energy efficiency. Many researchers have mentioned the useful effects of tree plantation such as reduction of pollution and noise, modification of relative humidity and temperature, psychological benefits for humans, and saving energy in particular. For instance M. Taheri (1999) did a study on the optimum tree plantation for energy saving. He stated that the amount cooling loads of the building can be reduced by 10-40% by optimum tree plantation. Moreover, he claimed, that tree is the best passive option for reducing summer loads through blocking sunshine, especially in the morning and afternoon, and for reducing an ambient air temperature, while having insignificant effects in winter by losing their leaves: it works complementary to window overhangs. Ram (2010) also did a study on the effects of tree shades on buildings. He indicated, that the annual energy for cooling can be reduced by 10-50% by proper shades and lessen electrical use about 23%.

Shading should to be provided in the way of landscaping and foliage. In summer, deciduous trees are effective for blocking of solar radiation and during the winter period, when it is not desired, they allow solar radiation penetration to the room. Fences are not climatically responsive, because they block solar radiation and view at all year long, so they do not change with climate change (American Institute of Architects, 2012).

Landscape designs and building must be closely integrated. If possible, wind-breaks should be provided in cold winter while it should be feasible for cooling breezes to

access during summer. Proper wind-breaks will add benefit or advantage, regarding low relative humidity, to the building through using natural air ventilation systems.

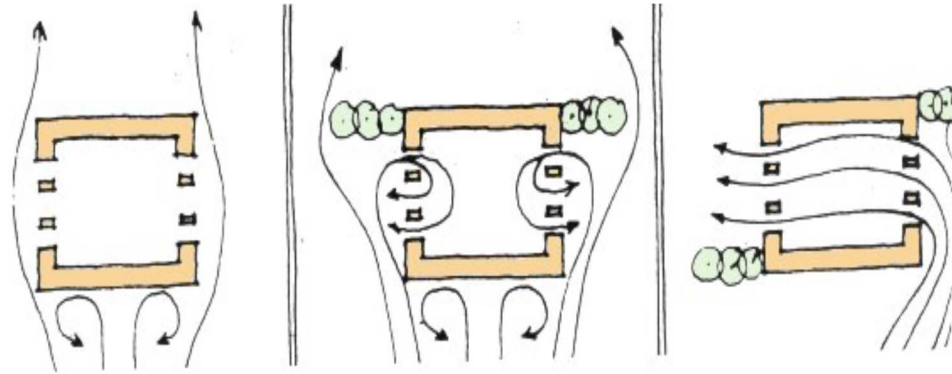

Figure 26: Wind control by trees (Brown, 2001)

Temperature in summer period can be reduced by using proper landscaping surface materials, such as grass or bare ground.

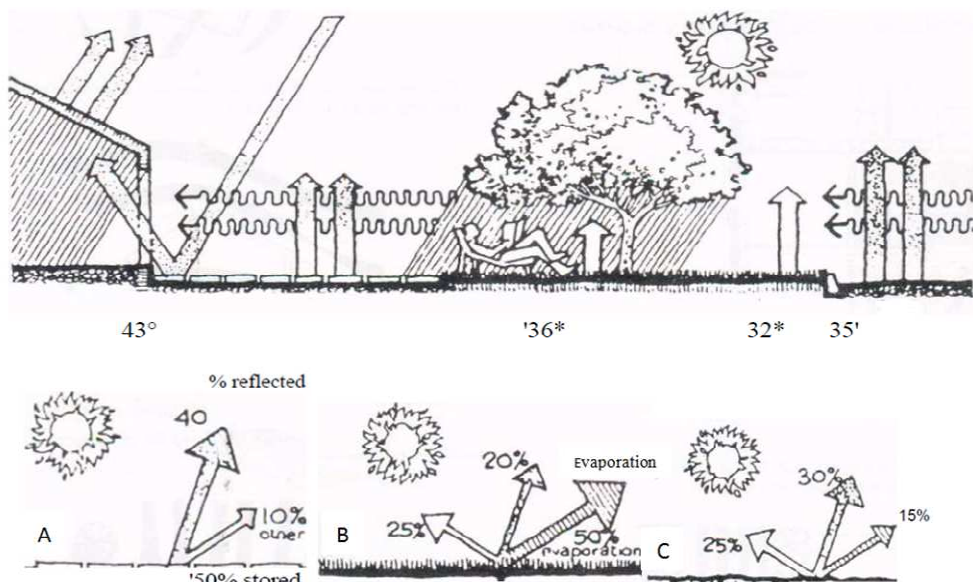

Figure 27: Absorption of heat by different surface materials: (a) Paving; (b) Grass; (c) Bare ground (American Institute of Architects, 2012)

2.12.5 Passive House Building Envelope

The building envelope consists of all elements of the construction which separate the indoor climate from the outdoor climate. The aim of the passive house is to construct a building envelope that will significantly minimize heat loss and optimize solar energy gain to reduce the space heating and cooling requirement to 15 KWh/(m² year) (Wimmers, 2009).

2.12.6 Roof

Roof is an important component in design when it comes to saving energy, because this building element receives a lot of solar radiation. Roof should insulate the building from too much cold, heat and humidity if it is high. Roof also should protect external walls from solar radiation by providing shading around the building (Sergio, 2012).

Sloping or pitched roofs are recommended over a flat roof because of leaking danger during heavy rains. The materials used in roofs should not be metals such as zinc, stainless steel, copper and aluminum, because of their high conductivity and corrosion problem by sulfur-dioxide in the atmosphere (Schüller, 2000). Roof design principles are:

2.12.6.1 Solar Shade

Proper external roof shading devices are very significant in controlling the amount of solar radiations disclosed to the space, which can cause huge reductions in cooling loads and lead to achieve indoor thermal comfort. Overhangs should be designed successfully to block solar radiation in summer time and allow it to enter the building in the winter period (Abdulsalam, 2011). Figures 28 shows, that

different solar radiation angles in winter and summer is significant while designing permanent solar shading devices such as overhangs.

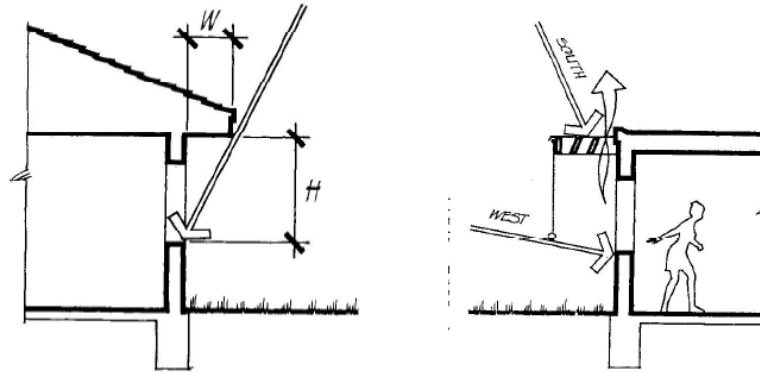

Figure 28: Roof shading components in hot climate regions (Watson, 1983)

2.12.6.2 Solar Reflection

Roof material and color impact a roof's ability to reflect solar radiation (Marco, 2012). It is claimed that, if the external roof surfaces are coating with such colors that reflect solar radiation, it minimizes absorption. However, if the long-wave is emitted higher than heat, fluidity transmitted to the building gets much reduced. In addition, in low solar-reflecting (highly absorptive) roofs, the difference between ambient air temperatures and surface may be as high as 90°F (50°C), but in high solar-reflecting (less absorptive) roofs, the difference is just about 15°F (8°C). Therefore, roofs which absorb little insolation are useful in reducing cooling energy use. According to Suehrcke (2008) heat transmission across a roof can be reduced around 20–70% by covering the rooftop with highly reflective coatings.

In order to control heat gain and loss from the roof, it is better to control heat transfer from roof by Suehrcke (2008):

- Covering the roof with reflective materials or paintings
- Ventilating roof spaces
- Insulating roofs

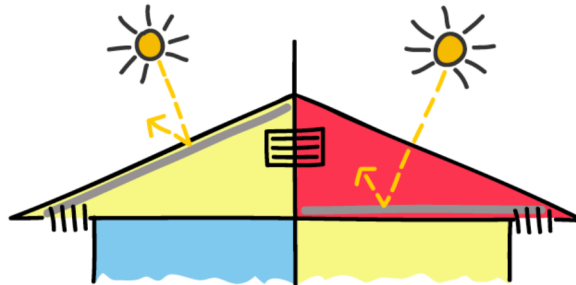

Figure 29: Reflective foil under the roof sheeting
(www.townsville.qld.gov.au/resources)

2.12.6.3 Thermal Insulation

Due to different angles of solar path in summer and winter, roofs are more exposed to solar radiation in summer (Figure 30). Not enough roof insulation leads to increase in heat transfer from roof to indoor spaces and accordingly having uncomfortable high indoor air temperature during summer.

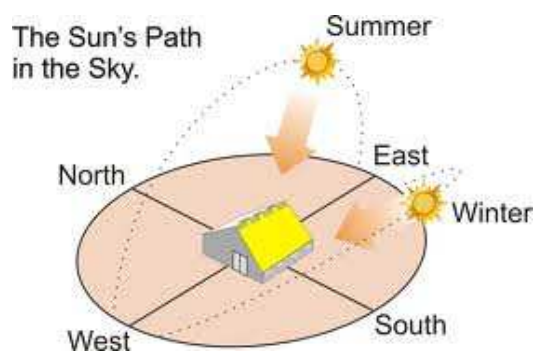

Figure 30: The arc of sun radiation in different seasons in northern latitudes
(www.tomorrowshomes.net)

According to Garde (2004), suitable insulation roof depends on the insulation material, color and thickness. Considering the position of roof insulation, insulation

for inclined and pitched roofs in hot climates can be placed on top of the rafters and below the tiles, or between roof rafters and for cold climate at ceiling level or inside surface of roof (Figure 31) (Passive-On, 2007). A well-managed and well-designed green roof can be used as a high-quality insulation device in summer, reducing the heat-flux through the roof.

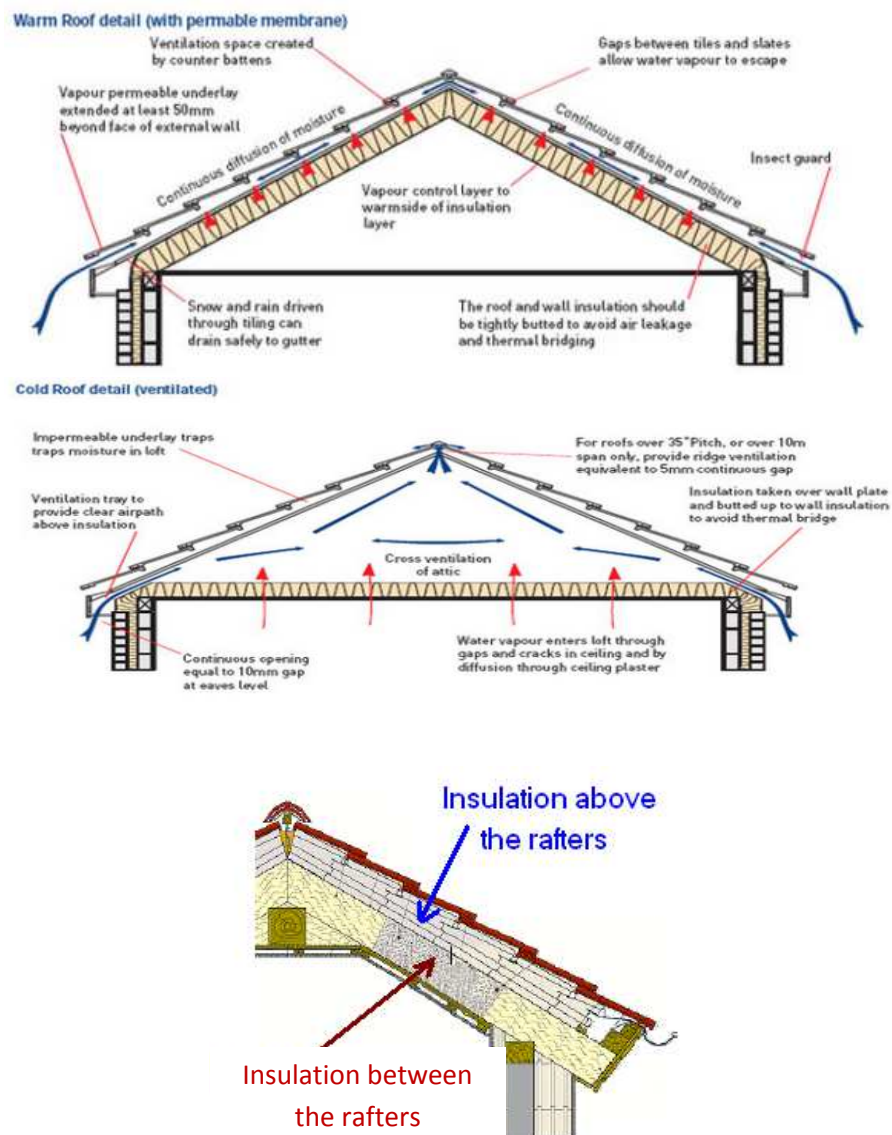

Figure 31: Different positions of roof thermal insulation (Passive-On, 2007)

The best roof insulation thickness depends on the region's climate and the specific requirements of the building. In a passive house, a typical U-value of the roof will be below 0.3 W/m²K in Southern European climates, and down to 0.1 W/m²K in Central Europe (Passive-on, 2007b).

2.12.6.4 Summary

Thermal performance of a roof depends on the geometry of ceiling, levels of thermal mass, level of ventilation (attic), insulation, external color and material reflection. All these issues can have effects on reducing energy requirements and amount of discomfort hours in a building.

2.12.7 External Wall

In different climates, protection is necessary against outdoor temperature and humidity; therefore, wall is an extremely important component in passive houses for implementing low energy strategies.

Using external wall gives the possibility of having a passive control over building indoor conditions by managing transference of external temperature (K.S. Al-Jabri, 2005). Generally, building materials with high thermal mass, such as cement block concretes, due to their properties, absorb heat from solar radiation at a much slower rate than light materials, such as timber or steels with a low thermal mass. Hence, light materials absorb heat quickly and respectively and cool down quickly, too. On the other hand, a composite construction wall may also be a suitable approach for local climatic conditions. Wall design principles in different climates are as follows:

2.12.7.1 Solar Shade

The effect of walls' solar protection is less significant than of windows. Walls' orientation impact on the building's indoor temperature is important: East and west

wall surfaces received more solar radiation than south and north ones. Therefore, shading should be provided on west walls by overhanging roofs, trees or evergreen vegetation (Garde, 2004).

2.12.7.2 Solar Reflection

The effective way of improving room performance is to use reflective surfaces and insulations to avoid high levels of solar gain: Color of the wall surface impacts the absorbability. In hot climates, white color is recommended much for a wall surface because the reflection it provides has the best performance and as a result, it reduces the need for insulation. On the other hand, in cold climates dark color is recommended (Al-Khishali, 2010).

2.12.7.3 Insulation

Wall insulation can reduce heat transfers through the wall construction. This leads to reduce in cooling and heating energy demands in a building. The effect is described by U-value, which includes the level of heat transfers through one square-meter of the wall area at a constant temperature difference of $1K=1^{\circ}C$ (Passive-On, 2007). Proper wall insulation reduces heat losses in winter, thus contributes to thermal comfort and energy savings of the building. On the other hand, in summer, wall insulation decreases the heat flow from outside to inside areas, reducing cooling load demands in the building.

Al-Homoud (2005) defines the optimum economic thickness of thermal insulation as “the thickness of insulation for which the cost of the added increment of insulation is just balanced by increased energy savings over the life of the project”.

If thermal conductivity of the insulation material is high, it means that the material has low thermal resistance. Consequently, an abundant thickness is necessary to

obtain optimal thermal insulation. Then undeniably, insulation material thickness is significant in the building's design for thick insulation and reduces the building's space significantly.

Thermal insulation is the main contributor and the initial practical and logical step in achieving energy efficiency, particularly in the envelope load of the dominated buildings located in regions with harsh climatic conditions.

Thermal performance of building envelope can be achieved by getting use of materials' thermal properties used in its construction. Choosing these materials should be based on their characteristics such as their ability to emit or absorb solar heat, and their overall U-value. Table 12 shows typical heat losses for different external walls, their U-values are based on a typical European single family house with an external wall area of 100m² in Central Europe (Feist, 2006b).

Table 12: Typical heat losses for different external walls and the annual costs caused by heat loss in external walls with areas of 100m² (Feist 2006b)

U-value	Heat loss Annual	Heat loss Annual	Annual costs of heat loss of external walls
W/m ² K	W	kWh/(m ² a)	EUR/a
1,00	3300	78	429.-
0,80	2640	62	343.-
0,60	1980	47	257.-
0,40	1320	31	172.-
0,15	495	12	64.-
0,20	660	16	86.-
0,10	330	8	43.-

The position of wall insulation can provide positive impacts on thermal performance of the building. Table 13 shows the considerations for the position of insulation.

Table 13: Different positions of wall insulations (*Al-Homoud, 2005*)

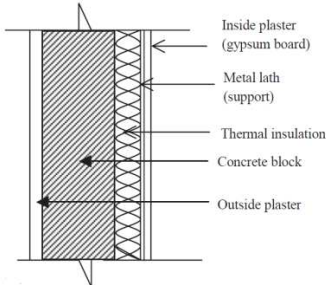
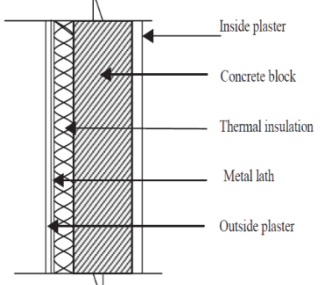
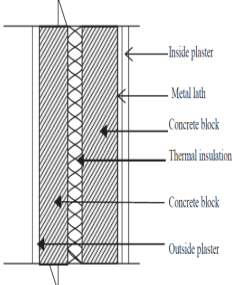
Insulation placement toward inside	Insulation placement toward outside	Insulation placement in the middle
<ul style="list-style-type: none"> - Protected by mass against outside environment and damage. The structure will be closer to the outdoor temperature. - Expansion and contraction becomes more important. - More thermal-bridges due to the unavoidable crossings and penetrations. Therefore, all joints and penetrations should be tightly sealed. - Minimized potential heating benefits from the mass of the building structure. 	<ul style="list-style-type: none"> -Support for summer convective cooling and winter passive-solar heating. - Allows mass to store internal gains and excess solar. However, less durability due to the exposure to damage effects and outside environmental. 	<ul style="list-style-type: none"> - Provides even distribution of the insulation in the component.
		

The best wall insulation thickness depends on the climate and specific requirements of the building. In a passive house, a typical U-value of the wall would be above 0.3 W/m²K in Southern European climates such as southern Italy or Spain, while the values of 0.15 W/m²K or below would be needed in Germany and France (Passive-on, 2007 b).

2.12.8 Window

2.12.8.1 Orientation

Gut et al. (1993) noted that major area of window should be orientate or faced to the south. While small area of window should be orientate to the north, east and west.

2.12.8.2 Shading Device

Shading device is a significant feature of many high-performance building design strategies. Good designed shading devices can considerably reduce a building's energy consumption and cooling load while enhancing daylight utilization.

The essential principle in shading strategy is to avoid direct solar radiation access to the building through heat absorbing materials, especially windows. This shading strategy can be achieved by sun control and natural devices (Ossen, 2005). Shading devices (sun control devices) can be classified under two categories of exterior and interior device:

- **Internal device:** Internal shading devices can be classified into two types. Solar shading devices such as screens, blinds, drapers and louvers, that shield against sunlight (solar radiation) and special-glazing for windows. According to Lam et al (2005) study on energy use and cooling load's requirements, heat gain happens through building envelopes. The study investigates on the effect of internal shading devices, e.g. Venetian blinds, on electricity use and cooling loads. They concluded that energy can be reduced by 14% using Venetian blinds.
- **External device:** External device is a very important element in reducing uncomfortable solar heat.

External device is more effective than internal device for its preventing solar radiations before reaching the vertical surface of the house. Heat reduction can

achieve its best results through preventing unnecessary heat rather than blocking (removing) it and dissipating in outside air. External device has three types: horizontal, vertical and egg crate.

The performance of movable (operable) devices is better than fixed devices. They can be adjusted by shading need and sun movement. On the other hand, fixed-devices are maintenance-free while movable (operable) ones need frequent maintenance to keep them in good conditions (American Institute of Architects, 2012).

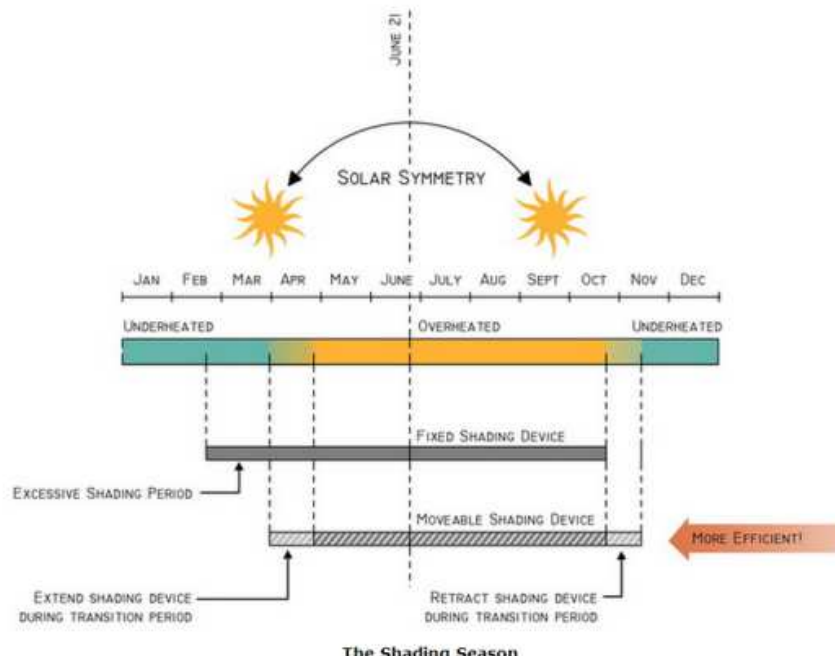

Figure 32: Efficiency of movable and fixed shading devices (American Institute of Architects, 2012)

However, shading device's length depends on its orientation, height of the opening, width of the opening, vertical shadow angle and horizontal shadow angle.

Ossen et al. (2005) evaluates the effect of horizontal shading devices in reducing the unnecessary solar heat gain and energy use in buildings.

They used different ratios of horizontal shading devices. The main results of the study are that horizontal shading device ratios of 1.6, 1.2, 0.8 and 0.6 had reduced direct solar radiation on windows by over 80%. Horizontal shading device ratios of 1.4 reduced transmitted heat gain in North and South by 35.9% and 38% respectively and in East and West by 48.9% and 45.4% correspondingly. Horizontal shading device ratios of 1, 1.1, 1.2 and 1.3 for North, South East and West orientations indicated optimum total energy savings of 6, 8, 11 and 14%.

The exposure of each façade to the sunlight (solar radiation) varies by building's orientation. Hence, shading design requirements are different for each orientation.

North elevation basically does not need shading because no sun penetration occurs, except for early mornings and late evenings in summer months. North elevation has high direct heat loss and very little solar heat gain, hence, the best way is to limit the openings on this elevation as much as possible. South elevations can easily control solar energy by horizontal projections above the openings. Both east and west elevations are difficult to shade (architecturally), because morning and afternoon sun angles are low enough to prevent shading with overhangs. Therefore, east and west elevation windows can be limited in size and be protected by vertical overhangs or trees (deciduous trees) (American Institute of Architects, 2012).

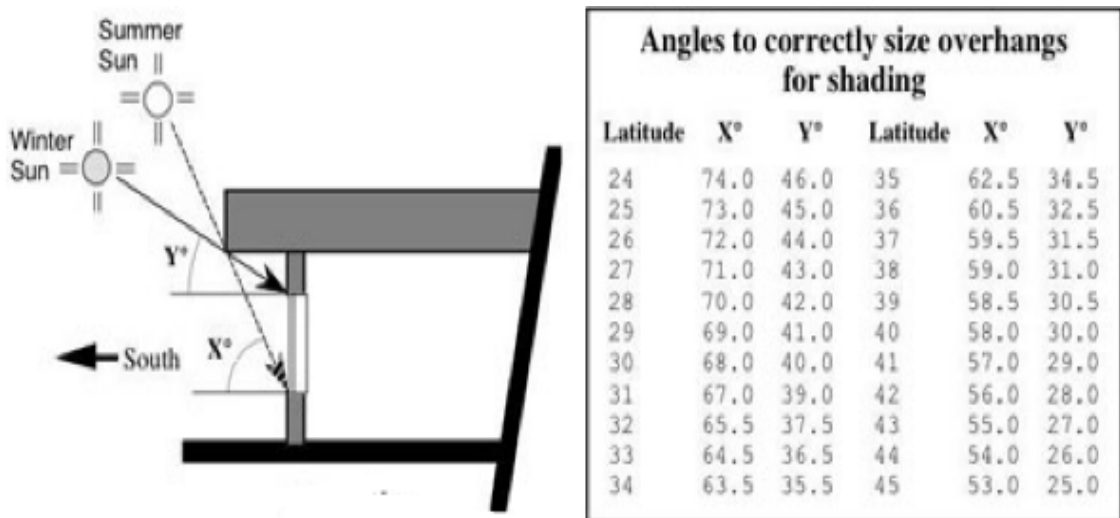

Figure 33: Basic shading strategy for a south elevation. (http://www.wbdg.org/references/fhpsb_guidance.php)

2.12.8.3 Size

Window is a significant design element or component for allowing solar radiation (daylight) and airflow, while providing cross ventilation and views. A large area window, in any façade of the house, can lead to lose a lot of heat in winter time and overheating in summer time by getting a lot of heat gains. Therefore, the optimum window size, i.e. the window to wall ratio (WWR), needs to reduce energy consumption for cooling and heating firmly, and to gain a maximum benefit from solar radiation in winter and summer periods.

In passive houses, south façade is the main area of windows; therefore, in this façade, the window size and glass type is very important to reduce heating demands.

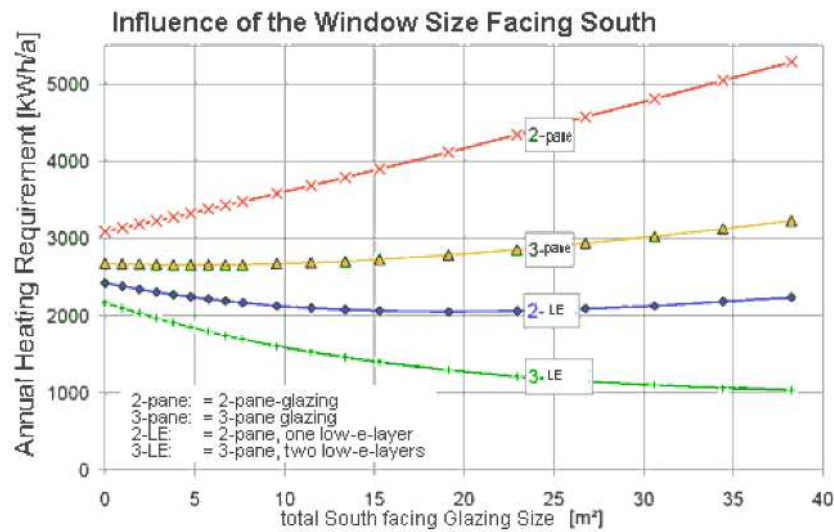

Diagram 12: Effect of different glazing qualities in the south-façade of a passive house (*PHI, 2006e*)

2.12.8.4 Ventilation (Air Movement)

Appropriate arrangement and organization of windows can be helpful in ventilation of the space or room and increase of air flow into the room for cooling. Air velocity inside the room depends on wind speed, direction and angle of the wind strike on the window, and size and location of the window (Heiselberg, 2006).

Table 14 shows a wind velocity of 12 to 23% in a room with a single opening and two openings in the same wall. Wind velocity can be improved in the room with two openings in adjacent walls, up to 51%, and in the two openings in opposite walls, up to 65% (Brown, 2001).

Table 14: Average indoor air-velocity as a percentage to wind velocity outdoor (Brown, 2001)

Opening height as a fraction of wall height	1/3		
Opening width as a fraction of wall width	1/3	2/3	3/3
single opening	12-14%	13-17%	16-23%
two openings in same wall	—	22%	23%
two openings in adjacent walls	37-45%	37-45%	40-51%
two openings in opposite walls	35-42%	37-51%	47-65%

Windows can be installed somehow in the wall to improve air flow and cooling such as in high openings, low openings, or both high and low openings.

Window design such as double-hung, jalousie, casement, ventilation louver design (projecting slabs) and wing wall (outward element next to a window) greatly affect the airflow and its direction.

2.12.8.5 Daylighting

Letting daylight into the house is a significant function of windows. The careful utilization of daylight technology can minimize the lighting costs by reduction of artificial lighting and at the same time it maximizes comfort in the house.

Many studies have been done for reducing energy used by day lighting, but there are all studies about office and commercial building.

For example (Bodart.M, 2002) in his study on the effect of daylighting on global energy savings in the building offices has used Adeline tool and TRNSYS software for determining the simulation. He figured out that daylighting can reduce artificial lighting consumption from 50-80%.



2.12.8.6 Glazing

Passive house buildings need highly effective windows. Choosing both glazing and frame types depend on the local climate. There are many glazing technology types with different properties. Glazing technology properties are:

- **Visible transmittance:** It is the percentage of visible light that can pass through a glazing. Its advantage is providing sufficient daylighting, clear glazing appearance, and keeping views unchanged. Yet, it can cause a glare problem.
- **Visible reflectance:** It is the percentage of solar radiation striking a glaze, and its reflectance. Visible reflectance glazing reduces solar radiation transmittance, so that glazing appears unclear.
- **Solar heat gain coefficient (SHGC)/G-value:** It is the pointer of solar heat gain, ranging between 0.1 and 0.9; higher value means higher solar gain.
- **U-value:** It measures the amount of heat transfer through glazing based on different temperatures between outdoor and indoor. Its lower value is better and it means low heat flow through the glazing. U-value is very important in reducing of cooling load in hot climates.

Therefore, while there are many types of glazing for passive house, the proper glazing is triple and double pane windows with low-emissivity coating. These window glazings reduce not only heat loss and achieve passive solar energy gain, but it increases thermal comfort as well (Table 15).

Table 15: Window types and their characteristics (PHI, 2012)

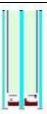
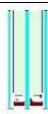
Glass type	Single	Double	Double low-E (Argon)	Triple low-E (Argon)	Triple Low E, (Krypton)
U-value (W/m ² K)	5.6	2.8	1.4	0.7	0.7
Internal surface (20 degrees in and -10 degrees out)	-1.8C	9.1C	14.5.3C	17.3C	17.3C
Solar transmittance	0.85	0.76	0.63	0.60	0.49
					

Chapter 3

ANALYSIS OF PASSIVE HOUSE STANDARDS IN DIFFERENT EUROPEAN COUNTRIES AND CLIMATIC REGIONS

3.1 Case Studies

The basic selection of case studies is based on the climate and location in different European countries. Therefore, Granada (Spain) is selected as a case study from a hot climate zone (Mediterranean climate), which is located in South West Europe. In order to compare with a cool climate, Hannover (Germany) is selected as a case study, which is located in Middle Europe and Gothenburg (Sweden), which is located in North Europe.

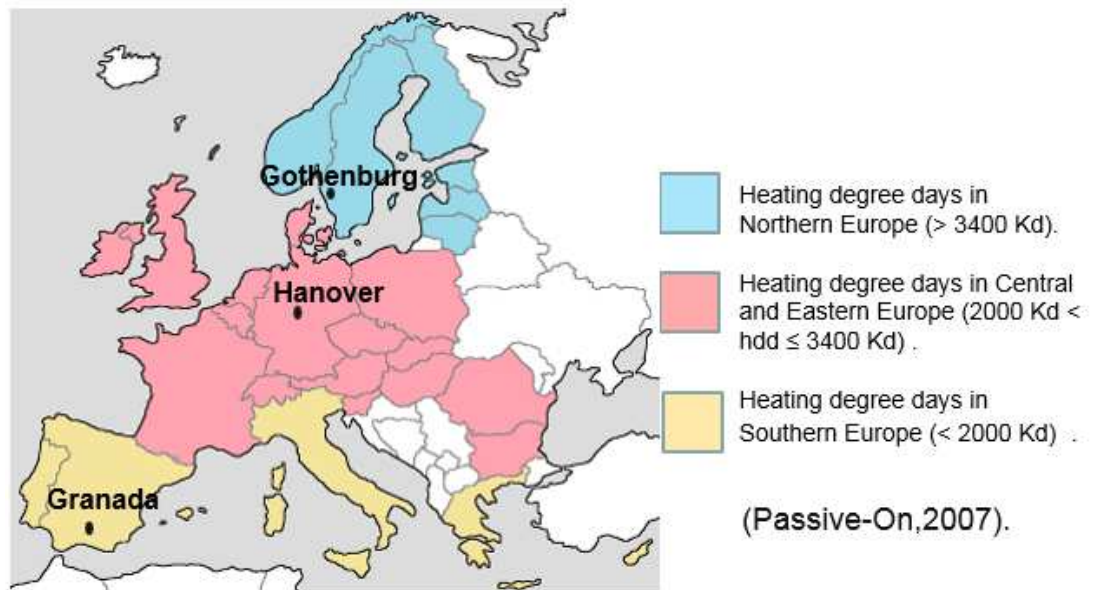

Figure 34: Locations of the case studies (Passive- on, 2007)

3.1.1 Spain

3.1.1.1 Granada's Climate Conditions

Recently, Spain started to have passive house building certification. In 2009, the first passive house was built in Llerida, Spain by Josep Bunyesc. Generally Spain's climate is a typical Mediterranean climate with hot-dry summers and mild-rainy winters (Assyce, 2010). Spain has three different climate zones due to its large area. Granada, which is located in the south within southern climate zone (37°35'N North Latitude, 05°00'W West Longitude), which has a hot temperate Mediterranean climate with hot dry summer and with wet moderate winter. It has high solar radiation (the summer solar radiation is 805.2 kW/m², the winter solar radiation is 239.3 kW/m²) with 11 hours of daily sunshine in summer and average humidity of 70%. The average air temperature is 28 °C with the maximum temperature above 35 °C in July and August and a minimum temperature of 2 °C in December and January. The average wind speed is 3.5 to 4, which is most often directed from the north. The average precipitation is 380 mm with a probability of snow. Figure 36 shows the weather in Granada.



Figure 35: Granada location (37°35'N latitude, 05°00'W longitude) (Google earth)

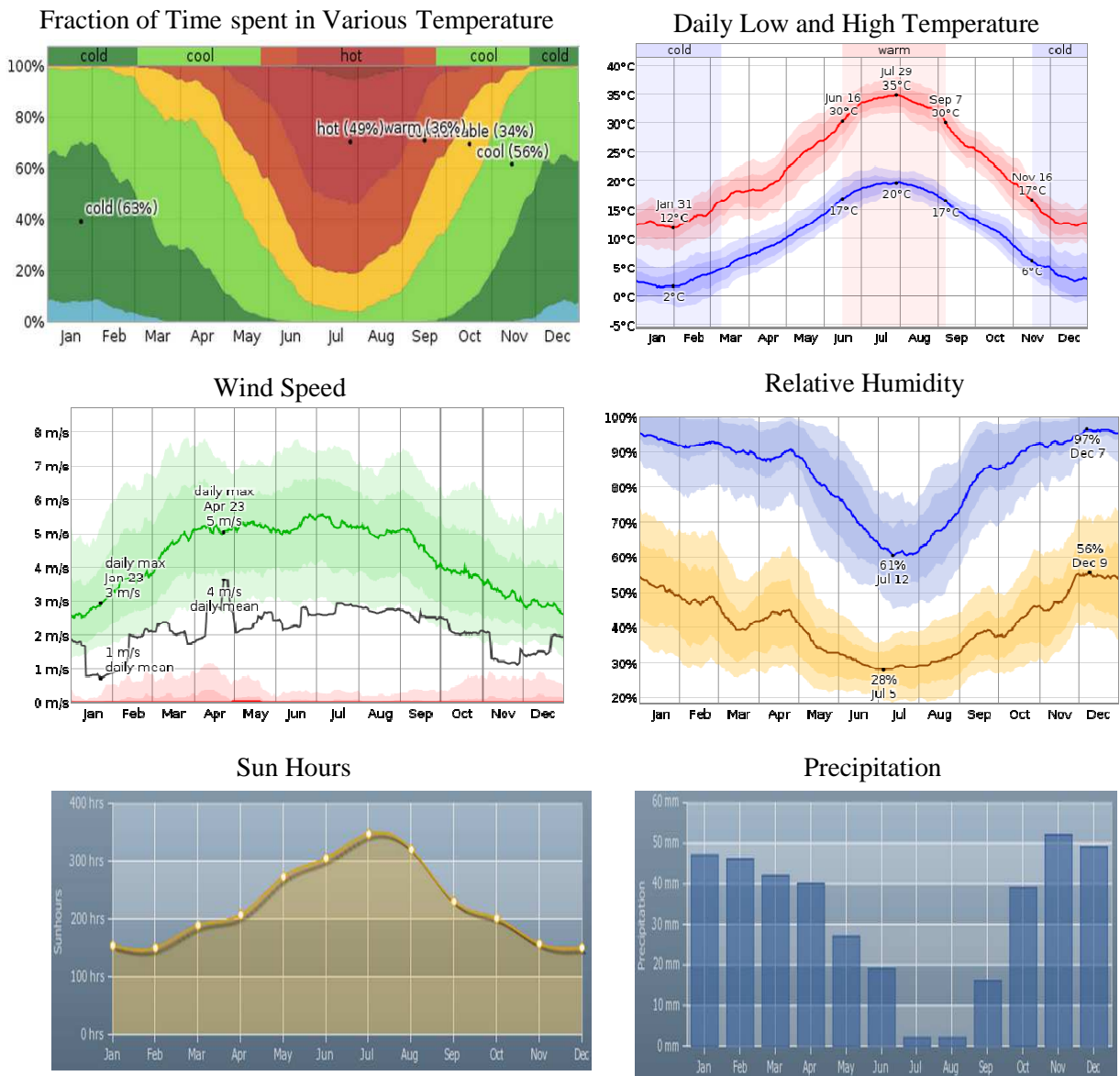

Figure 36: Granada weather (<http://www.weather-and-climate.com/average-monthly-Rainfall-Temperature->)

3.1.1.2 Granada (Moraleta) Passive House

In 2009, this case study was constructed in Moraleta de Zafayona, Granada, Spain.

It was designed for the solar park. It became a source for research of passive houses in Spanish climates, as well as being an interesting experience in the passive house community, due to being the only test for the area (Bunyesc, 2012).

3.1.1.3 Building Shape

The type of house is a detached single-family house, with an inhabitable net-area of about 99m², including a ground, a first floor, with a surface area (A)/ volume (V) ratio of 0, 85m⁻¹ and length to the width ratio is 2:1.

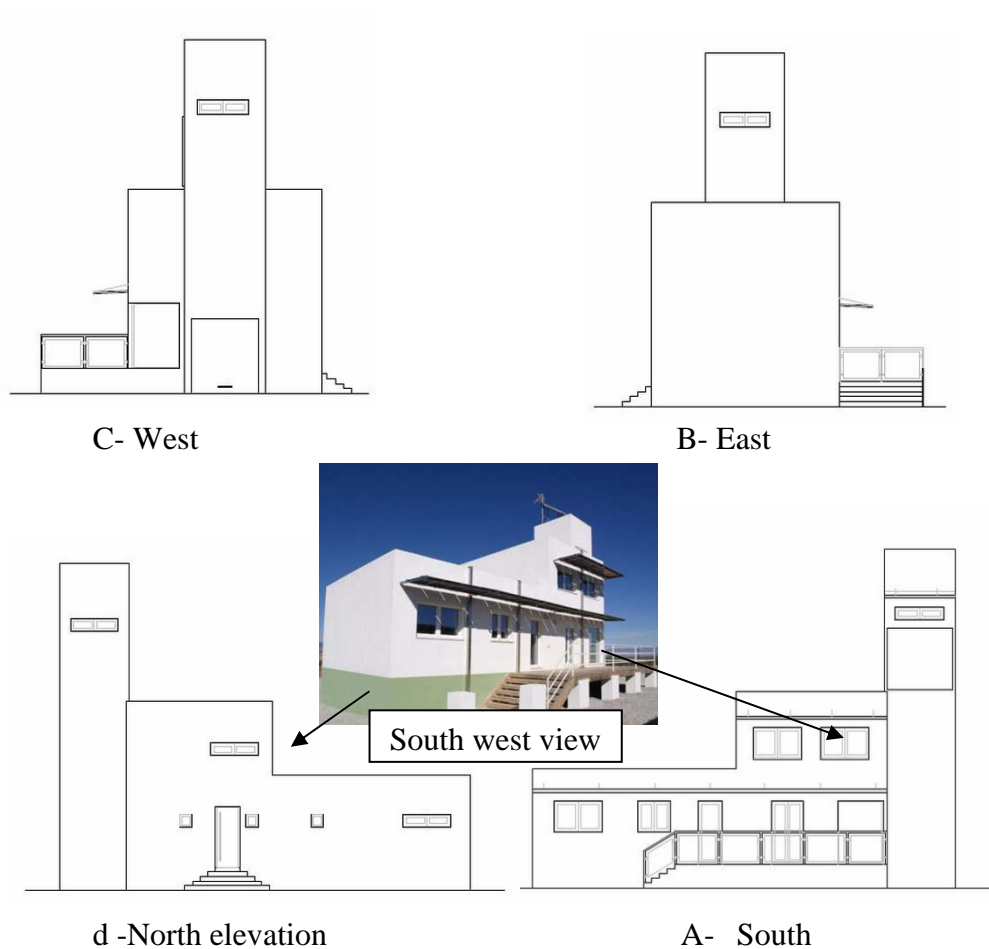

Figure 37: Granada passive house elevations: (a) South; (b) East; (c) West; (d) North (Assyce, 2010)

3.1.1.4 Orientation and Building Arrangement

The house has a floor area of about 100 m² and is designed with two levels for three residents. On the ground floor is the main entrance, two bedrooms, two toilets, a kitchen and a dining room. Upstairs there is a tower (Figure 38).

The building is oriented to the south and north. The living areas, which are oriented towards the south, consist of one bedroom with a toilet, a kitchen and a dining room with a living room, while north orientations consist of one bedroom with a toilet, stairs and an entrance (Assyce, 2010).



Figure 38: Granada passive house plans (Assyce, 2010)

3.1.1.5 Exterior Wall

The standard wall for the Granada house consists of a 15 mm plasterboard, 40 mm rock wool insulation, 35 kg/m³ steel plate ISO container, cement glue; 300mm polystyrene expanded (Neopor type, 032) cement façade and paint. The overall U-value of this wall is estimated at 0.09W/m²K. A white color is used in all the façades (Passive House Database, 2013).

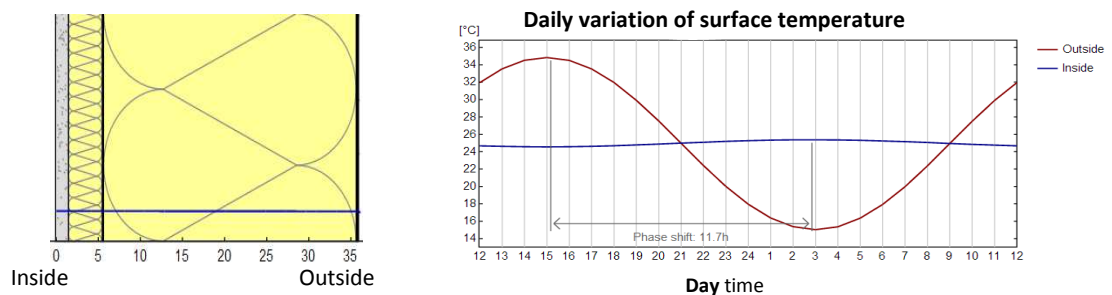

Figure 39: Cross-section of exterior wall and diagram of heat protection (<http://www.u-wert.net>)

3.1.1.6 Roof

The roof type used is a flat roof and it is composed of 100 mm stabilizing layer of concrete to cool heat loads in summer, 300 mm expanded polystyrene insulation (032) pending formation of concrete, geotextile, waterproofing bitumen and glass fiber reinforcement, geotextile, specific protection and clean gravel finish. The overall U-value of this wall is estimated at 0.10W/m²K (Passive House Database, 2013).

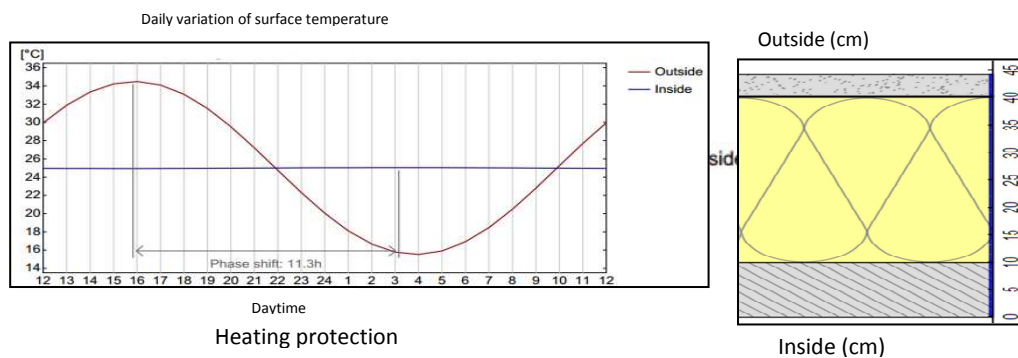

Figure 40: Roof section and diagram of heat protection (<http://www.u-wert.net>)

3.1.1.7 Floor

The basement floor slab is insulated with the same insulation like the walls. A reinforced concrete slab between 160 mm - 200 mm is insulated with expanded polystyrene neopor (032). The overall U-value of this wall is estimated at 0.185W/m²K.

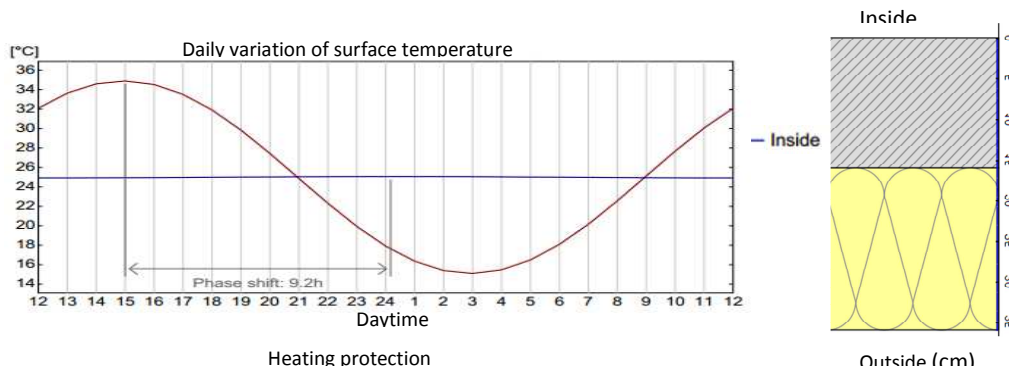

Figure 41: Floor section and diagram of heat protection (<http://www.u-wert.net>)

3.1.1.8 Glazing Façade and Shading

The correct selection of the glazed opening design and the installation are among the most critical components in creating a successful passive solar house, because it is the largest source of heat-loss in a house. The southern façade of the Granada passive house has a large area of windows, which is about 35% WWR (16.4m²). This high level of glazing increases the efficient use of solar heat gains during winter. While the east façade glazing is about 10% WWR (4.5 m²), the north façade glazing areas are smaller with about 8.5% (3.4m²), and the west façade glazing has the minimum area with about 1.5% (0.9m²). The small and narrow windows are used in the northern and western side of the building in order to minimize heat loss in winter and achieve day lighting requirements. All windows are prepared with exterior venetian blinds. In summer through the installation of PV modules, which is used as solar protection, are overhangs for southern façade of the building. At the same time it generates additional power energy.



Figure 42: Granada passive house shading device (Construible, 2010)

The Granada passive house has glazed windows with three panes of (4 mm and 12 mm) space, filled with argon, (4/12/4/12/4 mm). The overall U-value of this window

is estimated at $U_g\text{-value} = 0.75 \text{ W/ (m}^2\text{K)}$ and $g\text{-value} = 50 \%$ (Passive House Database, 2013).

The windows frames are composed of PVC (Gealan S800 Trend XL) and the frame dimensions are 6 chamber, 83mm deep, 66 mm high and have a white core. The overall U-value of this glass window is estimated at $U_w\text{-value} = 1.03 \text{ W/ (m}^2\text{K)}$.

The entrance door is made out of thick solid pine (35 mm), lacquered with polyurethane-lacquer exterior in the color of the wood interior and white. The overall U-value of this glass door is estimated at $U_d\text{-value} = 2.2 \text{ W/m}^2\text{K}$.

3.1.1.9 Thermal Comfort: Thermal Bridge - Air Tightness

The building has the passive house standard value with a thermal bridge of 0.01 $\text{W/m}^2\text{K}$ and an air tightness of $n_{50}=0.6/\text{h}$. Analyzing the results obtained from the monitoring of housing shows, how the application of the criteria-based passive house principles like insulation, air tightness, thermal bridge and renovation of housing can create a high thermal comfort, healthy atmosphere and very low power consumption. The inside temperature in summer is between 25-27 C (Assyce, 2010).

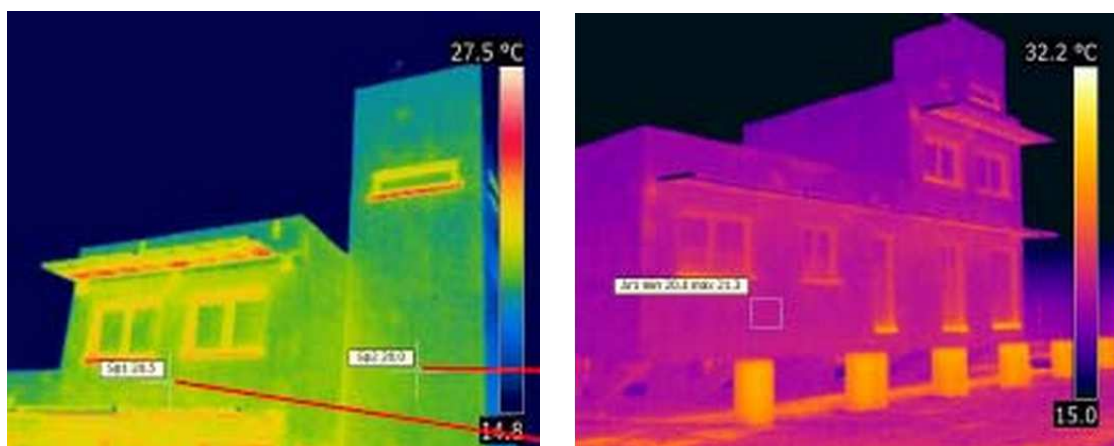

Figure 43: Thermal Bridge testing in Granada passive house (Assyce, 2010)

3.1.1.10 Heating & Ventilation

The Granada house has a controlled ventilation system with a Mechanical Ventilation Heat Recovery unit (MVHR), high quality anti-pollution filters, which ensure excellent air quality, which are especially useful in cases of allergies or respiratory problems, and are also suitable for large public buildings. The measures taken in order to insulate housing also provide acoustic comfort, and it saves and reduces 90% of air conditioning. In summer, the house can be naturally ventilated by opening windows (natural cross ventilation) and a small air-conditioning unit can be used for cooling (Construible, 2010).

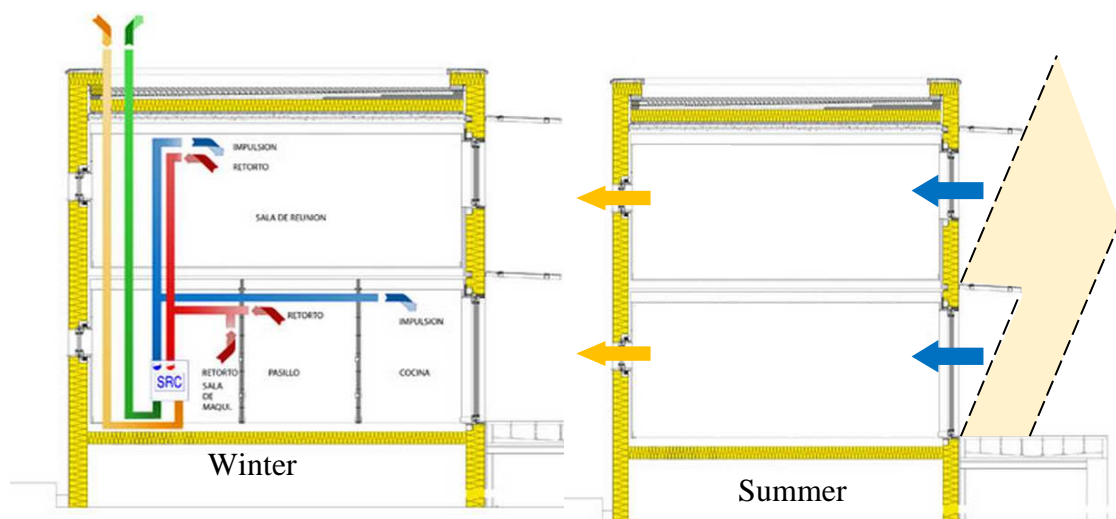

Figure 44: Summer and winter strategy of Granada passive house (Construible, 2010)

3.1.1.11 Domestic Hot Water

The solar thermal installation is done in order to meet more than 70% of the domestic hot-water requirements. The gross area of the solar collector is 4.36 m². The type and capacity of the storage is 300 l (MECALIA model DPAV/KEY 300) (Construible, 2010).



Figure 45: Granada passive house DHW (Construible, 2010).

3.1.1.12 Energy Performance

The certified housing gets a considerable reduction in heating and cooling energy consumption intended less than 15kWh per m², which has an annual heating demand of 6 kWh / (m²a) and a load of 6 W/m², and an annual cooling demand of 9 kWh/m²a and load 15 W/m² of living space. The global primary energy demand for heating, hot water, ventilation and other electrical devices is less than 120 kWh m², which is 67kWh/m² of the living space per year. This low power consumption saves up to 90% of the energy used for air conditioning (heating and cooling), and 80% of global energy consumed by a home built under the parameters of the Technical Building Code (CTE) (Passive House Database, 2013).

Furthermore, it has a positive energy balance, because it generates more energy than it consumes, through the installation of PV modules that is used as an overhang for the building.

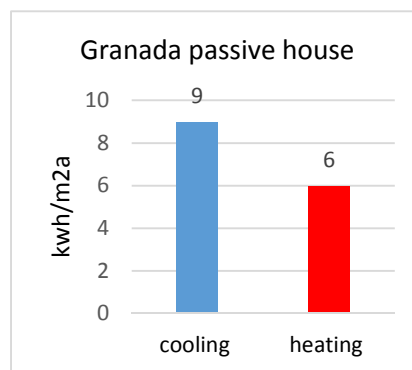

Diagram 13: Performance of Granada passive house (Passive House Database, 2013)

3.1.1.13 Economy and Cost

The Granada passive house adds costs about 3-5% when compared to conventional housing, but it is an investment, that is recovered over a period not more than two years (Construible, 2010).

3.1.2 Germany

The passive house in Hannover is selected as a case study, because it is located in Central Europe.

3.1.2.1 Hannover's Climate Condition

Germany has experience with passive house building, because Germany built the first passive house in 1991, which is located in Darmstadt-Kranichstein. However, the Hannover passive house is located in North Germany (Longitude: 9° 44' and Latitude: 52° 22' 90) (IEA, 2011a). It has a marine west coast climate, which is moderate with no dry season, warm in summers and moderate seasonality. It has a low level of solar radiation (monthly average solar radiation 0.71 kWh/m² d and HDD: 3379, 8, CDD: 0.00) and 50 hours of yearly sunshine and an average humidity of 80%. The summer average air temperature is 24°C with the maximum temperature above 30 °C, and a winter average temperature of 2°C with a minimum temperature below -8°C. The average wind speed is 4 -5 m/s daily, which is most often directed from the west. The average precipitation is 655 mm with snow. Figure 47 shows the weather data in Hannover.

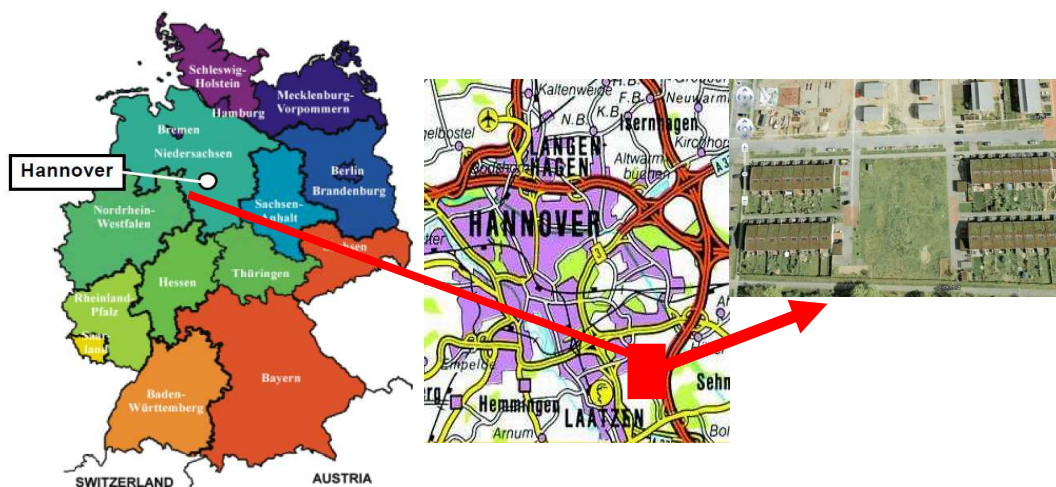

Figure 46: Hannover's location (52° 22'N Latitude, 9° 44' W Longitude) (Google earth)

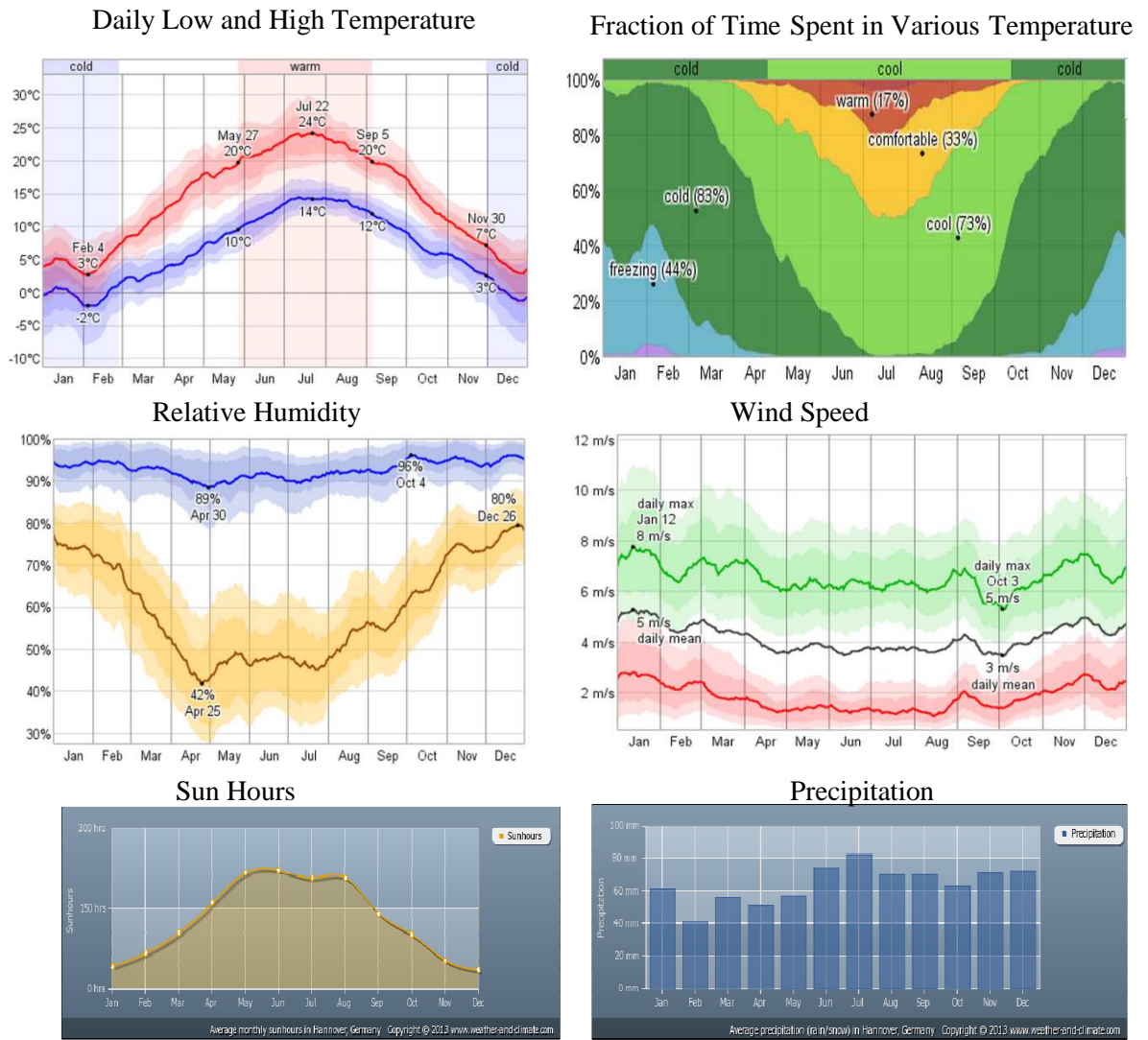

Figure 47: Hannover weather data (<http://www.weather-and-climate.com/average-monthly-Rainfall-Temperature->)

3.1.2.2 Building Shape

The project includes 32 terraced houses, and they are arranged in four rows with eight houses in each row. The houses are divided into three types with an inhabitable net-area of about 79, 97, and 120 m² floor area, including a ground and a first floor. The arrangement of houses offer the advantage of reduced A/V ratio, which is about 0.61 m⁻¹. The length to the width ratio is 1:2 (IEA, 2011a).



Figure 48: Architectural concept, north and south view (IEA, 2011a)

3.1.2.3 Orientation and Building Arrangement

The house is designed with two levels. The building is oriented towards the south with a deviation of 15° to the west. The living area, which is oriented to the south, consists of two bedrooms and a living room, while the north orientation consists of one bed room, a dining room and a storage room. In the middle there is a toilet, a bath, a kitchen and stairs (Figure 49) (Heiduk, 2009).

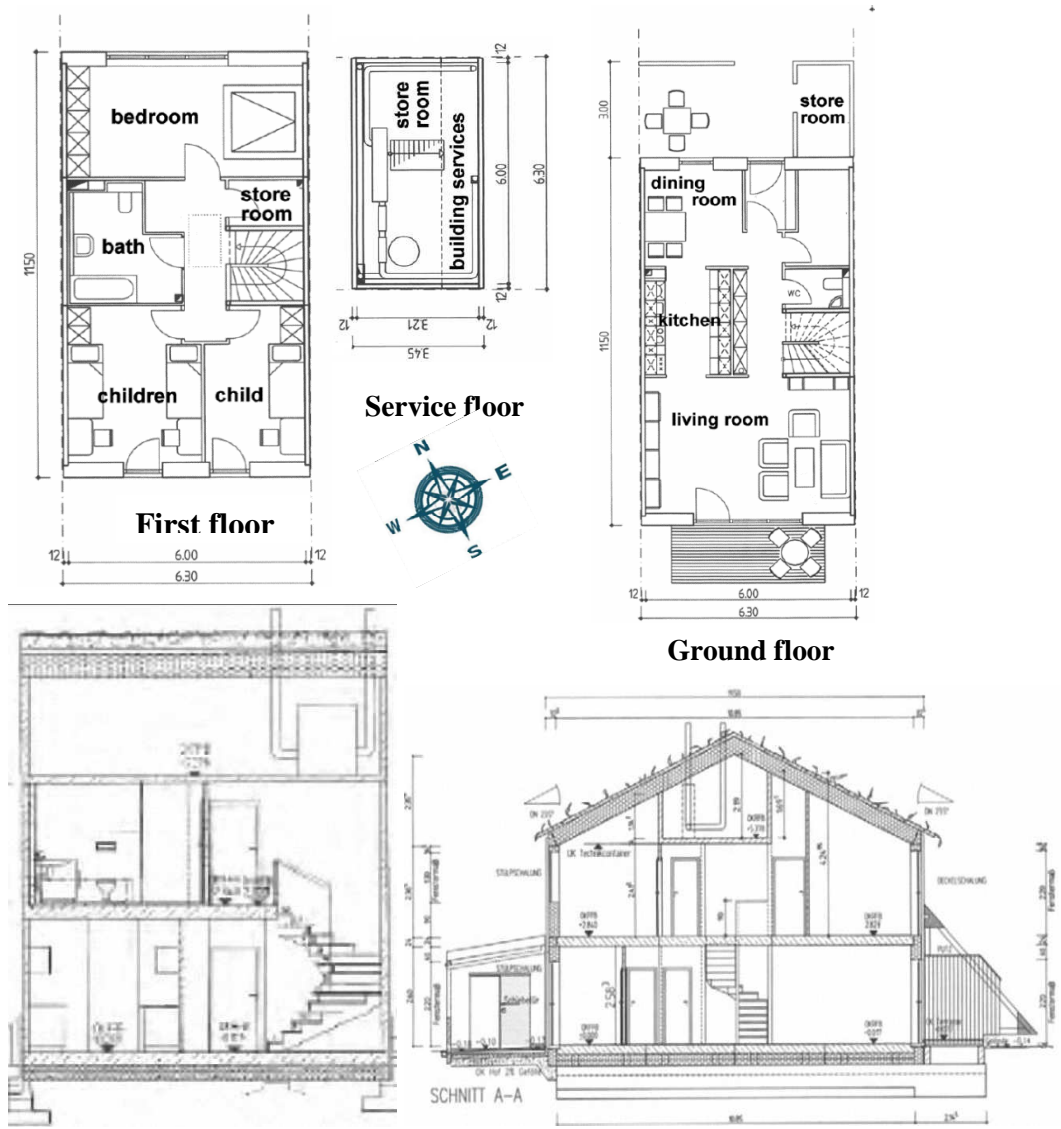

Section A-A The ceiling slab and the floor are solid with concrete, the external walls and the roof are prefabricated timber frame elements

Figure 49: Hannover passive house plans and section (Heiduk, 2009)

3.1.2.4 Construction and Thermal Envelope

The house was built in 1998 and its construction type is a mixed construction (timber and masonry). Roofs and walls are made out of light weight wooden construction and the building core, the end walls and cross walls are made out of pre-fabricated concrete elements (IEA, 2011a).

3.1.2.5 Exterior Wall

The standard external wall for the south and north façades (with prefabricated lightweight wood elements) consists of a 12.5 mm plaster board, 16 mm particleboard, 300mm box beam truss in-between mineral wool insulation, 16 mm particleboard and ventilated board casing. The overall U-value is 0,126 W/m²K.

While the external wall (gable side) consists of a 165 mm prefabricated concrete element, 400 mm EPS polystyrene hard foam thermal insulation compound system and 8 mm plastered on the outside. The overall U-value is 0,097 W/m²K. This is illustrated in the Figure 50. A blue color is used for the south façade (Feist, 2003).



Figure 50: Hannover passive house exterior wall cross section (Heiduk, 2009)

3.1.2.6 Floor Slab

The floor slab is composed of 20 mm wood flooring, 5 mm tread absorbing insulation (PE-foam), 150 mm Concrete slab, and 300 mm/420 mm insulation (final houses). The overall U-value is 0,125 W/(m²K) (middle houses) and U=0,091 W/(m²K) (end of row) (Feist, 2003).

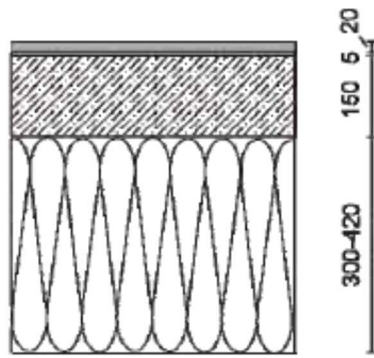

Figure 51: Hannover passive house floor slab cross section (Heiduk, 2009)

3.1.2.7 Roof

The roof slope is 35 degree and is composed of 12.5 mm plaster board, 19 mm particle board, 400 mm I- truss in-between mineral wool, 25 mm particle board, roof sealing green roof system. The overall U-value is 0,095 W/m²K (Feist, 2003).

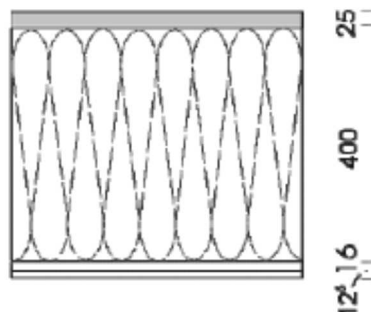

Figure 52: Hannover passive house roof cross section (Heiduk, 2009)

3.1.2.8 Glazing Façade: Shading, Type and Frame

The southern façade of the Hannover passive house has a large area of windows, which is about 36% WWR; this high level of glazing increases the efficient use of solar heat gains during winter. The northern façade is glazed about 19.4% WWR. While east and west façades do not have a glass area (0%). In summer, a manual driven shading system protects the rooms from temperatures that are too high. In winter, solar gains through windows cover around one-third of space heating energy requirements.

The house has glazed windows as triple glazing (2*16 mm) with argon gas filling, and a wood frame construction with a core of polyurethane foam or other insulating material. The wood is painted white, with an exterior covered white aluminum. The overall U-value is 0,083 W/m²K and g is 60%.

3.1.2.9 Thermal Comfort: Thermal Bridge - Air Tightness

The buildings have very high value in terms of thermal bridge with 0.01 WMK(mK) and air tightness with n50 = 0.3/h.

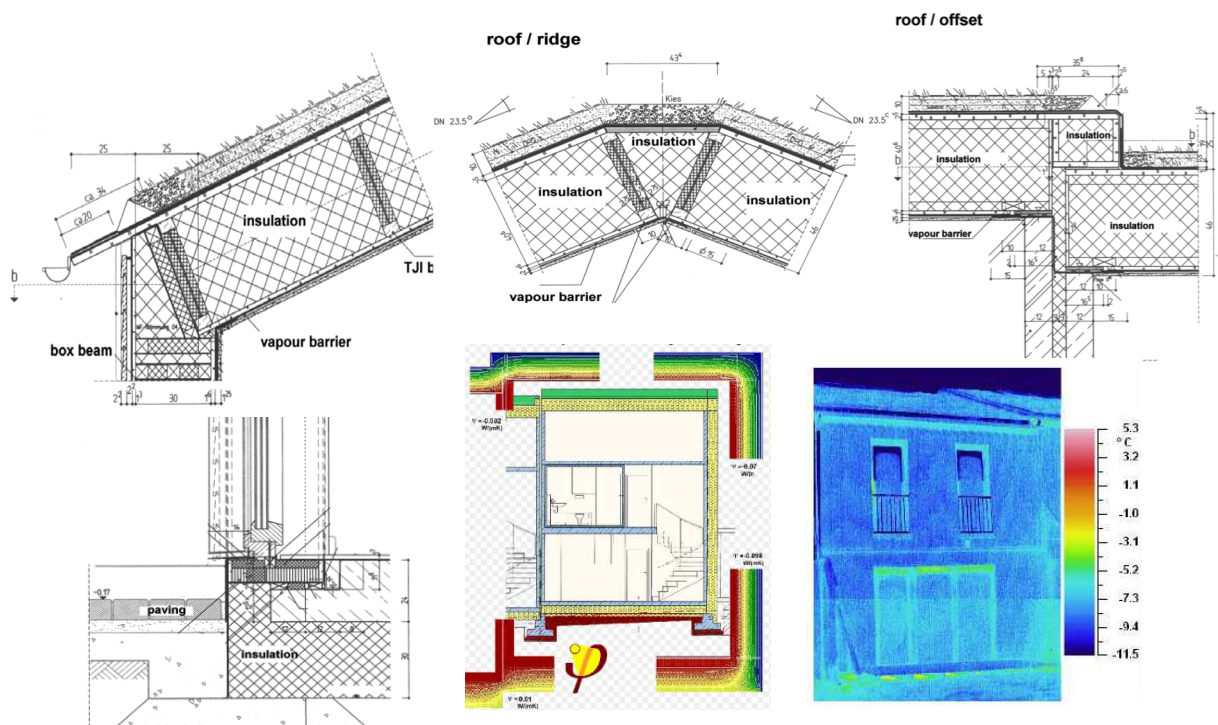

Figure 53: Details and cross-section of Hannover Thermal-bridge (IEA, 2011a)

The large internal-masses (concrete) function with the high quality thermal-insulation in combination with the support to keep the temperatures in summer on a moderate-level, if cross-ventilation in the night is applied. In summer the inside temperature is between 23-25°C and in winter, it is between 20-23°C (Heiduk, 2009).

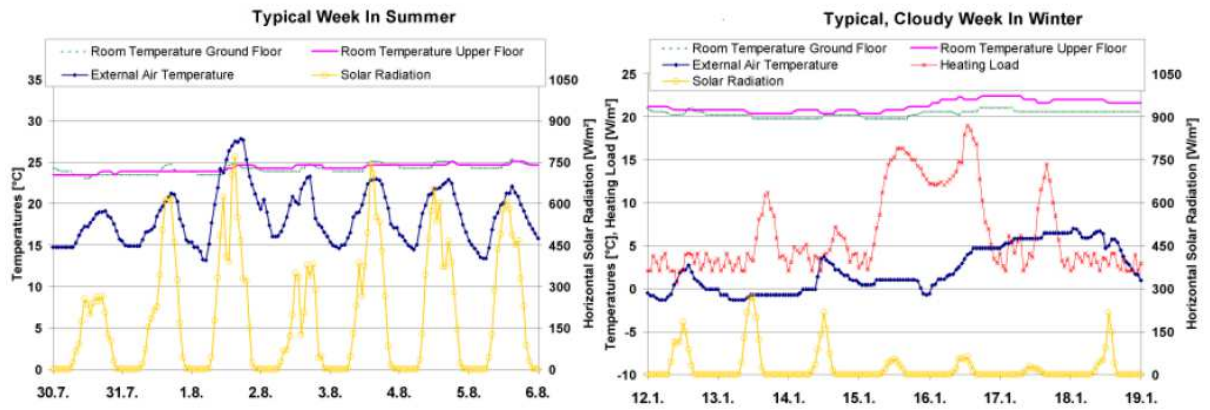

Figure 54: Hannover Thermal Performance (Heiduk, 2009)

3.1.2.10 Domestic Hot Water (DHW)

The water heating is performed by district heating from a gas-fired CHP plant. The fresh air is a hot-water coil, which is fed from the hot-water tank, which is reheated. Flat plate solar collectors are about 3.8 m² gross areas. The capacities of the storage is 300 l (Heiduk, 2009).



Figure 55: Hannover domestic hot water (DHW), solar hot water storage and supply-air heater (SAH) (Heiduk, 2009)

3.1.2.11 Ventilation

The house has a controlled ventilation system with a mechanical ventilation heat recovery, which is located in the attic. The efficiency of heat recovery is about 78%

with a minimal electricity consumption less than 2.3 kWh/m²a. In summer, the house can be naturally ventilated by opening windows (natural cross ventilation).

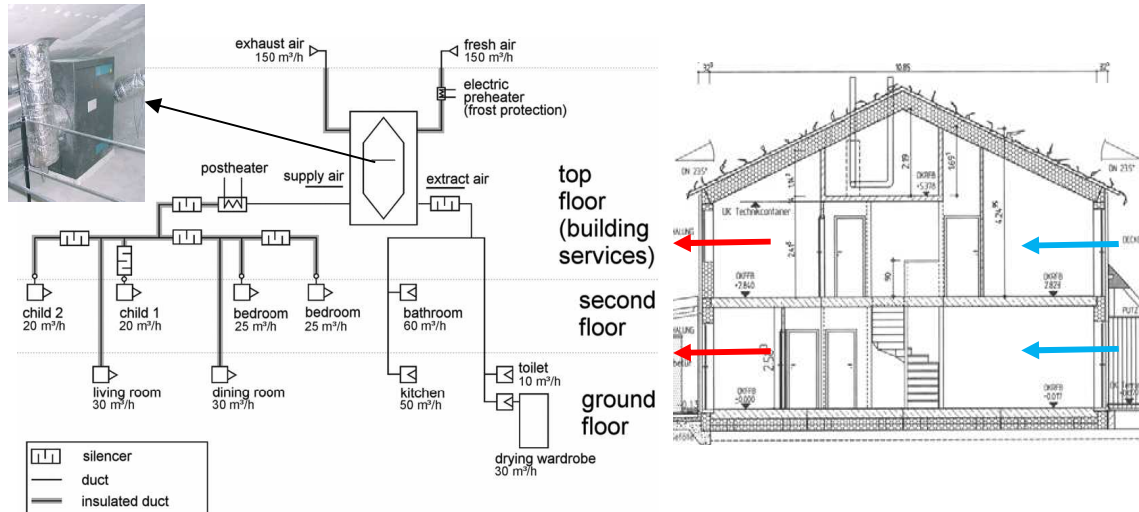

Figure 56: Diagram ventilation system in Hannover passive house (Heiduk, 2009)

3.1.2.12 Energy Performance

The certified housing gets a considerable reduction in heating energy consumption with an annual heating demand of 15 kWh/m²a. This value saves energy use up to about 90% when compared with the stock building and about 86% for new terraced housing. And the annual primary energy demand for all sources; heating, hot water, ventilation and other electrical devices is 82.6 kWh/m²a. This value is approximately 66% less than similar new houses in Germany. The final energy consumption or the district heating system is 34,6 kWh/ (m²a) that save approximately 75% more than German new buildings (Heiduk, 2009).

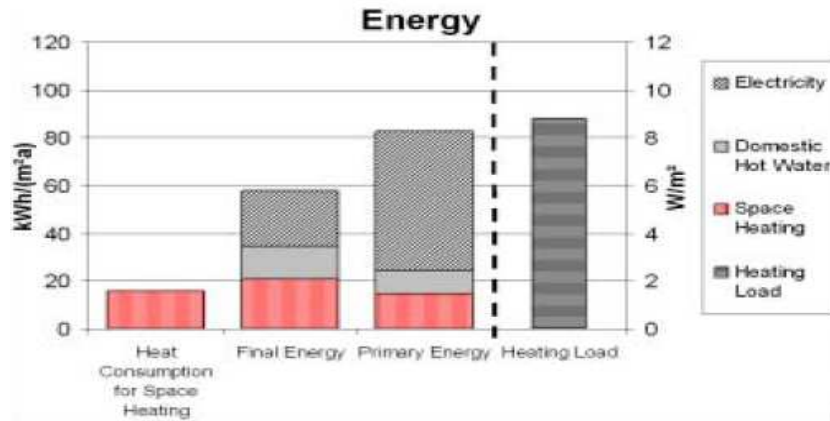

Diagram 14: Energy performance (Heiduk, 2009)

3.1.2.13 Economy and Cost

Hannover passive house, adds costs up to 12.4%, when compared to the German ordinance 1995, which includes total extra investment efficient appliances (1022 EUR). The total costs of construction per m² living area 119.53 m² is about 871.57 EUR/m², but it is an investment that is recovered over a period of 25 years. The costs of kWh have saved 6.2 Cent/kWh.

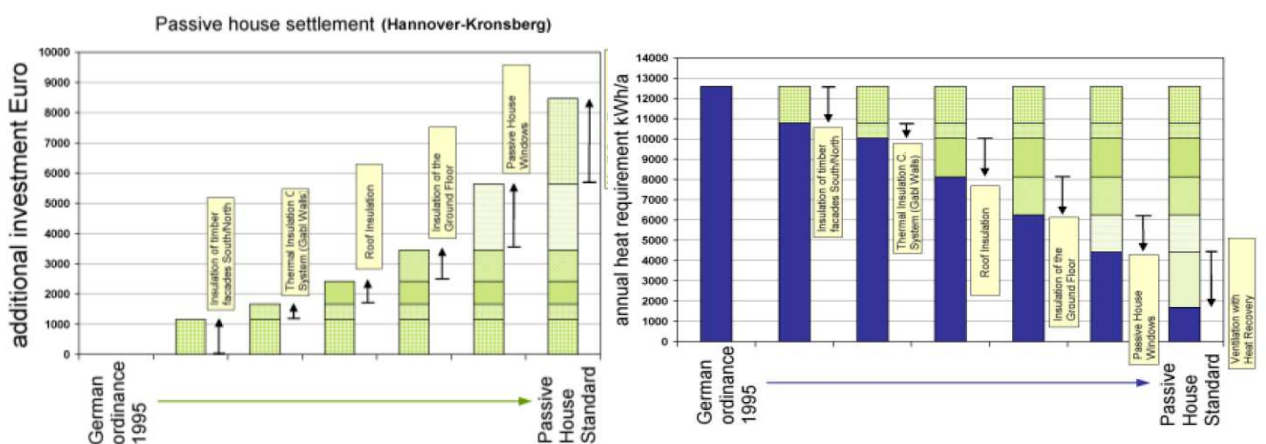

Diagram 15: Additional investment of Hannover passive house (Heiduk, 2009)

3.1.3 Sweden

The passive house in Gothenburg was selected as a case study from a cold climate zone, which is located in North Europe.

3.1.3.1 Gothenburg Climate Conditions

In 2001, Sweden started with passive house building certification. The first passive house was built in Bildal Gothenburg (Sweden). However, Lindås is located 20km south of Gothenburg in South Sweden (Latitude: 57°43'N, Longitude: 11°59'E) (Janson, 2009). Gothenburg enjoys a mostly temperate climate with no dry season, warm in summer and very cold in winter. It enjoys global horizontal irradiation (900 KWh/m²) with an annual sunshine of 1928 h. The summer average air temperature is 20°C with the maxima above 27°C and winter average temperature -4°C with a minimum below -13°C. The average wind speed is 4-5 m/s daily, which is most often directed from south-west. The average humidity is 80% and the average precipitation is 670 mm with snow. Figure 58 shows the weather in Gothenburg.



Figure 57: Gothenburg location (Latitude: 57°43'N, Longitude: 11°59'E) (IEA, 2011)

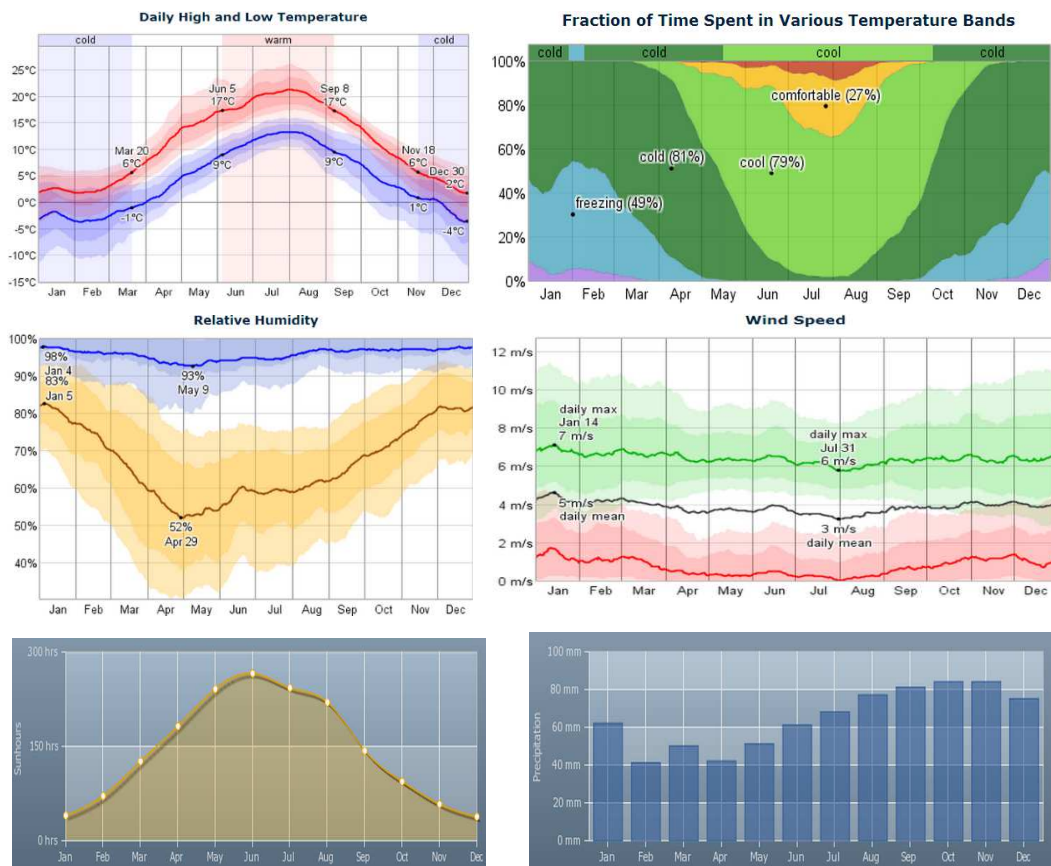

Figure 58: Gothenburg weather data (<http://www.weather-and-climate.com/>)

3.1.3.2 Building Shape

The project includes 20 units of terraced houses, and they are arranged in 4 rows. The houses are divided into two types, with an inhabitable net-area of about 120m² and a 124m² floor area including a ground floor and a first floor. The arrangement of houses offers the advantage of reduced A/V ratio, which is about 0.60 m⁻¹. The length to the width ratio is 1:2.



Figure 59: Architectural concept, north and south view (Janson, 2009)

3.1.3.3 Orientation and Building Arrangement

The house is designed in two levels with an attic. The building is oriented to the south-north. The living area is oriented towards the south, and there are two bedrooms and a living room, while the north orientation consists of one bedroom, a bath, a kitchen, an entrance and a storage room. In the middle, there is a toilet, a bath, a dining room and the stairs (Figure 60) (IEA, 2011).

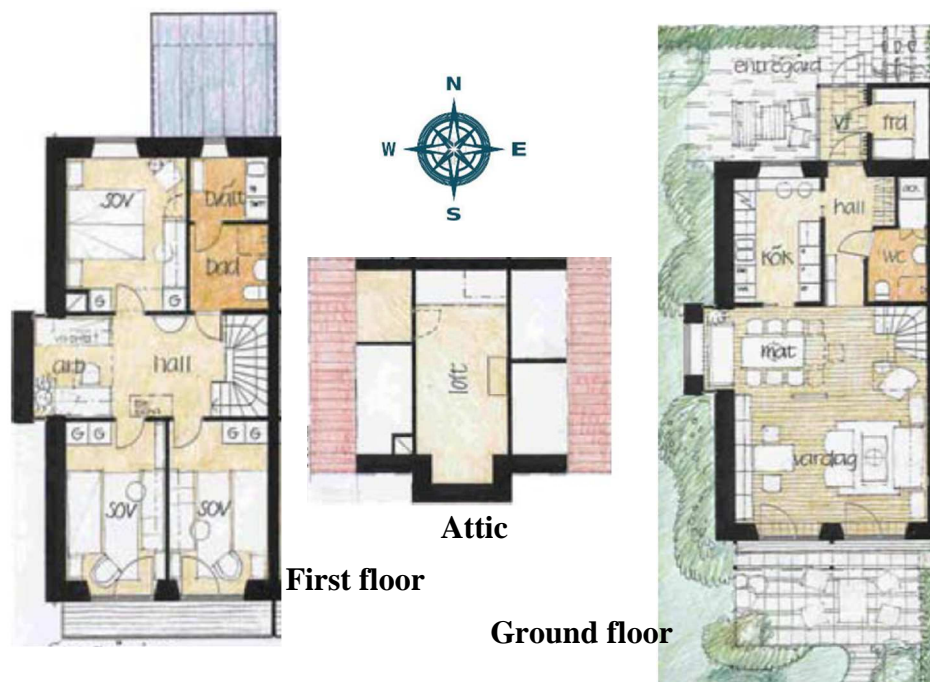

Figure 60: Gothenburg passive house plans (IEA, 2011)

3.1.3.4 Exterior Wall

The standard external wall (outside) consists of a 22 mm wooden battens, an air gap, 120 mm polystyrene, 13 mm plasterboard plate, 170 mm vertical wooden bars, 600 mm rockwool insulation, an air tightness layer / vapor barrier (PE foil) 100 mm polystyrene, 45 mm timber frame with mineral wool and gypsum board. The overall U-value is 0.09 W/m²K with a thickness of 51.3 cm, which is colored in black (IEA, 2011).

3.1.3.5 Basement Floor / Floor Slab

The floor slab is composed of a 300 mm washed gravel, 250 mm polystyrene, 100 mm concrete, porous polyethylene film, and 22 mm parquet. The overall U-value is 0.09 W /m² K with a thickness of 68 cm (IEA, 2011).

3.1.3.6 Roof

The roof is composed of tiles with furring strips, 20 mm polystyrene, 19 mm solid wood, 50 mm air gap, masonite 1200 mm with 45 cm mineral wool, an airtightness layer / vapor barrier (PE foil), 45 mm timber frame with mineral wool, gypsum board. The overall U-value is 0.08 W/m²K with a thickness of 67 cm which is coloured in red (IEA, 2011).

3.1.3.7 Glazing Façade: Shading, Type and Frame

The southern façade of the Gothenburg passive house has a large area of windows, which is about 45% WWR. This high level of glazing increases the efficient use of solar heat gain during the winter season. The glazing of the northern façade is about 20% of the WWR, while eastern and western façades (the building at the end of the row) have 8% WWR (Constructing-Excellence, 2007).



Figure 61: North and south façade windows (Janson, 2009)

In summer, the roof overhang and balconies provide protection against overheating of interior space. In winter, passive solar energy gain is achieved through windows, which covers around one-third of the space heating energy demand. The roof-windows are above the staircase, which provides natural daylight for the building core. It is also utilized for effective ventilation during the summer.

The windows of the house are glazed by triple glazing with two metallic-coats and krypton gas filling, a wood frame construction with a core of polyurethane foam or other insulating material, wood painted white and an exterior aluminum cover which is yellow. The overall U-value is 0.08 W/m²K and the light transmittance is g=68% and the energy transmittance is 50% (Figure 62).

3.1.3.8 Domestic Hot Water (DHW)

For the hot water supply, a flat plate solar collector of 5m² gross area is used to cover about 40-50% of the hot water demand. The capacity of the storage tank is 500 l (Janson, 2009).



Figure 63: Gothenburg passive house solar collector (Janson, 2009)



Figure 62: Window frame (Janson, 2009)

3.1.3.9 Ventilation

The house uses mechanical ventilation heat recovery, which is located in the attic. The efficiency of heat recovery is about 80% with $P=70$ W. In summer, there is a probability to turn off (automatic bypass) the heat exchanger, and the house can be naturally ventilated by opening the windows from both sides (natural cross ventilation) and roof windows. The space heating demand can be covered partly by heat gains from the lighting and energy-efficient appliances (2900 kWh/year), and from the occupants (circa 1200kWh/year). The residual space heating demand can be covered through electric-resistance heating (900 W) (heating coil to prevent freezing in the heat exchanger) (Constructing-Excellence, 2007).

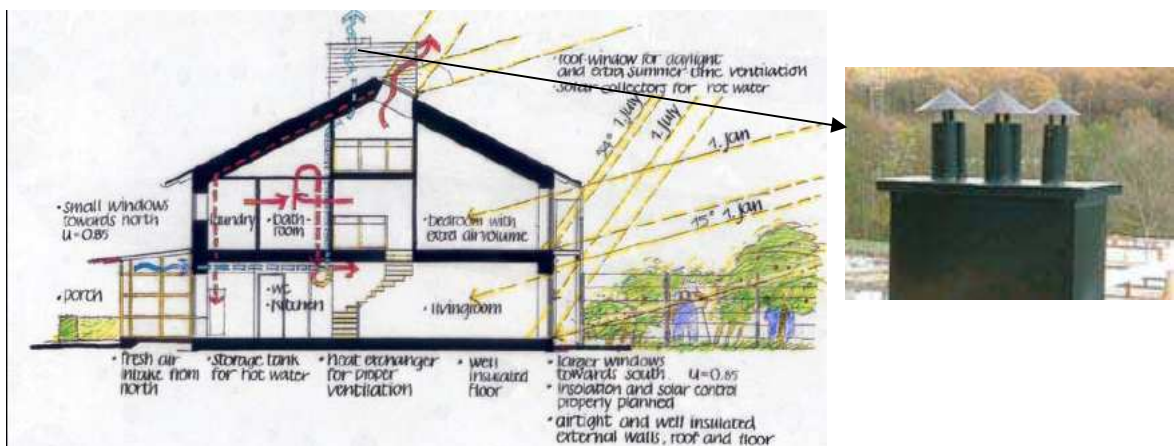

Figure 64: Ventilation system in Gothenburg passive house. (Constructing-Excellence, 2007).

3.1.3.10 Thermal Comfort: Thermal Bridge - Air Tightness

The buildings have very good value in terms of thermal bridge with 0.01 W/m²K and an air tightness with $n_{50} = 0.3$ /h (Constructing-Excellence, 2007).

3.1.3.11 Energy Performance

The houses' energy performance has been calculated. The annual heating demand is 14 kWh/m²a. This value saves energy use up to about 85% in comparison to the existing building. Heating, hot water, ventilation and other electrical devices varies between 45 and 97 kWh/m²a. This value is approximately 50 – 75% less than similar new houses in Sweden. The final energy consumption or the district heating system is 29.5 kWh/m²a, which saves nearly 76% more than Sweden's existing buildings (Janson, 2010).

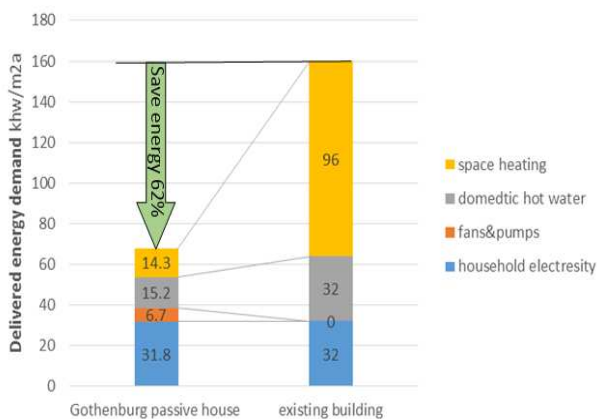

Diagram 16: Gothenburg passive house energy performance (Janson, 2010)

Table 16: Energy performance for Gothenburg passive house (Janson, 2010)

Heating of space and ventilation air (electrical)	14.3 kWh/m ²
Domestic hot water (Elec.)	15.2 kWh/m ²
Fans and pumps	6.7 kWh/m ²
Lighting and appliances	31.8 kWh/m ²
Delivered energy demand	68.0 kWh/m²
Domestic hot water (solar energy)	8.9 kWh/m ²
Total monitored energy demand	76.9 kWh/m²

3.1.3.12 Economy

According to the CEPHEUS projects, the additional costs or additional investments of the Gothenburg passive house use about 2% for renewable energy compared to Sweden's ordinance. The costs of kWh save 4.4 Cent/kWh. The extra cost for both windows and insulation is about 15,000-20,000 SEK, and the extra cost for the heat exchanger is about 10,000 SEK, the total additional cost is 40-50.000 SEK (3,000£-3,800£) (IEA, 2011).

Chapter 4

ANALYSIS AND RESULTS

4.1 Main Learnings from the Investigation and Analysis of Three Existing Passive House Buildings in Different European Countries and Climates

In this chapter, the results of the analysis from the case studies will be explained based on the main criterias of the passive house standards and finally summarised.

4.1.1 Climate

Passive House constructions used in Central Europe cannot be assumed to work unconditionally in other parts of the world. It is important to develop passive house solutions for each location, suitable for the actual climate and geographic conditions. Local building traditions as well as national/local building regulations must also be considered.

4.1.1.1 Heating (Winter)

In winter, Granada compared with Hannover and Gothenburg has much more solar radiation. The solar radiation can be effectively used for heating the passive houses in Granada.

Hannover and Gothenburg have less solar radiation during the winter season in comparison to Granada. Consequently, the passive house in Granada requires less thermal insulation in comparison to the passive houses in Hannover and Gothenburg.

4.1.1.2 Cooling (Summer)

Granada is warmer than Hannover and Gothenburg in summer. The passive house of Hannover and Gothenburg cannot be applied directly to Granada, because of the overheating of indoor spaces in summer.

Granada passive house needs cooling in summer due to overheating of interior spaces in summer. Consequently, passive house's energy cooling load must be reduced with passive solar strategies.

Granada has higher solar radiation in comparison with Hannover and Gothenburg during the summer season. It should be controlled through shading devices, which should be very effective for cooling of passive house in Granada during the summer months.

Table 17: A climate comparison between passive house examples

Climate		Granada	Hannover	Gothenburg
Latitude (°)		37°35' N	52° 22' N	57°43'N
Longitude (°)		05°00"E	9° 44' "E	11°59'E
Humidity		70%	80%	80%
Global horizontal irradiation		1800	1100	900
Winter design weather data	Outside design temperature(°C)	-1	-8	-13
	Wind speed (m/s)	2.5	5	5
Summer design weather data	Outside design temperature (°C)	36.5	29	25
	Wind speed (m/s)	4-4.5	3.5	3
Seasons	Warm season	17.06.–09.09	27.05-5.09.	05.06-08.09.
	Cold season	13.11.–06.03.	30.11.-27.02.	18.11.-20.03.
Solar radiation kWh/m2	Winter	2.4	1.7	1.2
	Summer	8	5.9	5

4.1.2 Building Shape

The optimum building shape for European passive house is different due to the different climate, but commonly rectangular with a compact design (long axis running from east to west and minimized east and west exposures). This shape has the minimum thermal loss in winter and in summer.

Due to the examples, the suitable length to width ratio for the passive house is 2:1.

The compactness in all passive house examples is high.

4.1.3 Orientation

Due to the passive house examples the optimum building orientation is south–north orientation. Granada and Gothenburg are facing to south, while Hannover is facing to south-west.

4.1.4 Building Arrangement

The building arrangement is different in the selected passive house examples due to the solar orientation and prevailing wind direction. Generally, figure 65 shows a conceptual zoning about the spaces in a passive house.

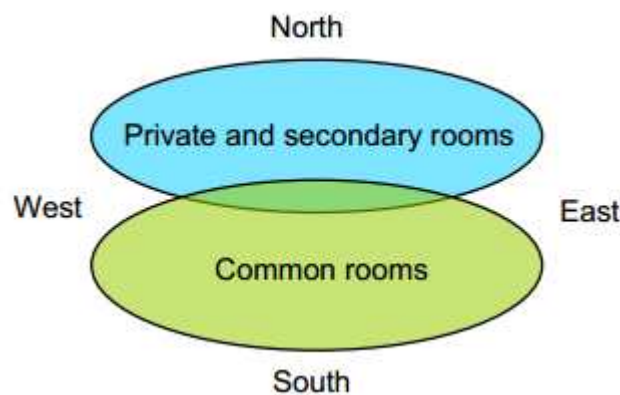

Figure 65: Functional organization of the passive house
http://vbn.aau.dk/files/60383597/2011_02_02_Samlet_afhandling_Camilla_Brunsgaard.pdf

4.1.5 Roof

Due to the example of passive house, the roof must be tightly fixed, sloped or pitched recommended for the cold climate zone. The flat roof is not desirable because of the danger of leaking during heavy rains and snow. While Granada passive house uses flat roof, which is covered by clean gravel as finishing material to reduce heating transmission of solar radiation from the roof. The roof should be insulated the building from too much heat, cool and humidity. The position of roof insulation for inclined and pitched roofs in hot climates can be placed on top of the rafters and below the tiles, or between roof rafters. The position of roof insulation in cold climate zone can be placed at ceiling level or inside of the roof surface. It should protect the house from solar radiation. The roof thermal insulation becomes thinner by moving passive houses from a colder climate to a hotter climate like Granada, because the difference between outdoor temperature and indoor temperature is decreasing (Table 18).

4.1.6 Wall

The east and west wall surface should be reduced to minimum due to receive more solar radiation from the south. Therefore shading should be provided to the west exterior walls by overhangs, deciduous trees and evergreen vegetation. The passive house in Granada uses white colour for the exterior wall to achieve high solar reflection to reduce the cooling load. On the other hand, Hannover and Gothenburg use mid-dark and dark colours to absorb solar radiation to reduce the heating demand. To avoid thermal loss in winter and in summer, the placement of thermal insulation for the hot climate zone, according to the Granada passive house, is preferred to the outside wall surface, while the case studies for the cold climate zone, Hannover and Gothenburg passive houses, have preferred the thermal

insulation layer as cavity material. The wall thermal insulation thickness decreases by moving the passive houses from a colder climate (Gothenburg, Hannover) to a hotter climate (Granada) (Table 18).

4.1.7 Window and Shading

According to the passive house case studies, maximum windows are oriented towards the south, to increase the effectiveness or to benefit from solar radiation in winter season to achieve passive solar energy gain. While no windows (Hannover) or minimum windows (Gothenburg and Granada) are preferred to the east side, west and north side windows have to decrease the thermal loss of interior spaces. The window size of the southern façade decreases from a colder climate (Gothenburg = 45%) to a hotter climate (Granada=35%) due to the high solar radiation (Table 18).

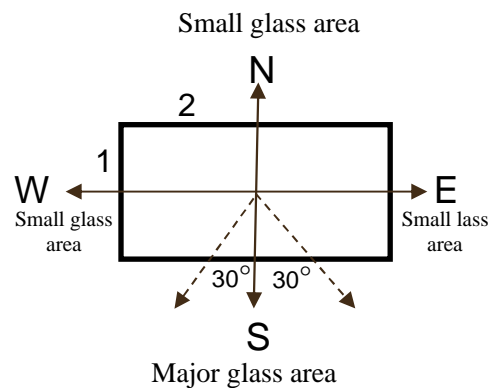

Figure 66: Best orientation and major glass area (Author)

All passive house examples are using triple glazing due to high energy efficiency to reduce the heating demand in winter and the cooling demand (hot climate zone in summer). The control of solar radiation (to avoid the overheating of interior spaces in summer) by shading devices is more required in Granada than in Hannover and Gothenburg due to the high solar radiation. Therefore Granada passive house uses

exterior Venetian blinds and PV louvers, while Hannover passive house uses moveable shading system, and Gothenburg passive house uses roof overhangs and balconies to avoid overheating of interior spaces in summer (Table 18).

4.1.8 Domestic Hot Water Supply (DHW)

When the heat loss through external walls is minimized, the domestic hot water requires the highest energy demand. For domestic hot water supply, solar energy use is recommended for passive house. The efficiency of hot water supply increases by moving the passive houses from a colder climate (Gothenburg, Hannover) to a hotter climate (Granada), due to the high level of solar radiation.

4.1.9 Thermal Comfort: Thermal Mass

Thermal comfort in all passive house examples is high. The indoor temperature in Hannover is in summer between 23-25 C, and in winter between 20-23 C, while the indoor temperature in Granada is in summer between 25-27 C. It can be concluded that in different climate zones passive house can achieve high thermal comfort.

Due to the examples of passive house, the passive house in hot climate zone (Granada) uses heavy construction, while the passive house in Hannover uses mixed construction (light, heavy), and the passive house in Gothenburg uses light construction as thermal mass. Due to the case studies, the heavy thermal mass is more suitable for hot climate, and the mid and light thermal mass is more suitable for cold climate to achieve thermal comfort (Table 19).

4.1.10 Ventilation

Mechanical ventilation is an irreplaceable part of passive house because of many reasons. It is not possible to use efficiently energy source with random window openings as well as good indoor air quality. All examples of passive house use heat

recovery with high efficiency and low power supply (Table 18). In summer, natural ventilation (single and cross) can be used to achieve thermal comfort.

4.1.11 Airtightness

The effect of airtightness is significant to reduce energy consumption. The air tightness is lower in a cold climate than in a hot climate, because heating demand is more sensitive to the air tightness than the cooling demand. Granada passive house need $n_{50}=0.6/h$ while Hannover and Gothenburg passive houses need $n_{50}=0.3/h$ (Table 18).

4.1.12 Passive Solar Heating and Cooling

Due to the passive houses examples, shading of a house is an important principle in passive solar cooling, because more windows have been installed, while the improvement of shading is required as well, especially the shading by window reveals needs to be considered especially from high solar radiation in summer. The direct gain is an important principle in the passive solar heating system in winter.

Table 18: Building constructions and components compared between passive house examples (Author)

Building construction and component		Granada	Hannover	Gothenburg
Building type		Detached single family house	Terraced house	Terraced house
Construction type		Insulated concrete forms	Mixed construction (timber and masonry)	Timber construction
Building area		100 m ²	79, 97, and 120 m ²	120-124 m ²
Surface/Volume - Length/Width		0,85(m-1) -2:1	0.61 (m-1) -1:2	0.62 (m-1) - 1:2
Exterior Wall	U-value W/(m ² K)	0.09	0,097	0.09
	Insulation thickness	30 cm	40 cm	43cm

Roof	U-value W/(m ² K)	0.1	0,095	0.08
	Insulation thickness	30 cm	40 cm	48cm
Basement floor / floor slab	U-value W/(m ² K)	0.185	0,125-0,091	0.09
	Insulation thickness	20 cm	30-42cm	30cm
Windows	Frame W/m ² K	1.03	0,083 (60%)	0.08 (68%)
	Glazing W/m ² K (factor)	0.75 (50%)		
Wall - Window ratio	South – East (end row)	35% - 10%	36% - 0%	45%-0% (8%)
	North –West (end row)	8.5% - 1.5%	19.4% - 0%	20%-0% (8%)
	Average	13.75%	13.85%	16%
Air tightness		n50 = 0.6/h	n50 = 0.3/h	n50 = 0.3/h
Heat Recovery Efficiency		90%	78%	80%
Solar Collector	Area and storage	4.36m ² -300 l	3.8m ² -300 l	5m ² -500 l
	Efficiency	70%	55%	40-50%

Table 19: Strategies compared between passive house examples (Author)

Strategies	Granada	Hannover	Gothenburg
Ventilation	Mechanical ventilation (heat recovery), natural cross ventilation in summer	Mechanical ventilation (heat recovery), natural cross ventilation in summer	Mechanical ventilation (heat recovery), natural cross ventilation in summer
Glazing	High level in south and minimum glazing in north and triple glazing is used with argon gas filling	High level in south and minimum glazing in north and triple glazing is used with argon gas filling	High level in south and minimum glazing in north and triple glazing is used with krypton gas filling
Thermal mass, insulation	Heavy construction, 30cm thermal insulation for wall and roof	Mixed (light, heavy) construction, 40cm thermal insulation for wall and roof	Light construction, 43cm insulation for wall and 48cm insulation for roof
Shading	Exterior Venetian blinds	Moveable shading system	Roof overhangs and balconies
Passive heating	Direct gain	Direct gain	Direct gain
Renewable energy	Solar collector with PV	Solar collector	Solar collector

4.1.13 Energy Performance and Economical Aspect

- Energy performance in all examples is high which can save over 62% of primary energy and more than 85% of the heating demand. Granada passive house has an extra measurement, which is the cooling demand and it can save about 90% of the cooling demand.
- The total additional cost investment is different due to economic and technological factors. Due to the examples of passive house, the higher total additional cost investment is about 12% (Table 20).

Table 20: An energy performance comparison between passive house examples (Author)

Energy performance	Granada	Hannover	Gothenburg
Primary energy kWh/m ² a (save)	67 (80%)	82.6 (66%)	76 (62%)
Annual heating demand kWh /m ² a (save)	6 (90%)	15 (93%)	14.3(85%)
Annual cooling demand kWh /m ² a (save)	9 (90%)	-	-
Total additional cost investment	3-5%	12%	2%

4.1.14 Summary

Passive house in different European countries and climate zones is not an energy performance standard, but a concept to achieve high indoor thermal comfort condition at low building costs. The basic idea of passive house is a well-insulated, airtight construction with mechanical ventilation (highly efficient heat recovery), avoiding of thermal bridge in the building envelope, utilization of passive solar energy and internal gains. Building components are necessary in all situations. The building envelope (roof, wall and windows) and ventilation system, which should be

optimized to reduce the energy demand for space heating and cooling as low as possible. Renewable energy sources should be used as much as possible to meet the required energy demand inclusive the domestic hot water supply (DHW).

Table 21: The characteristic features of passive house (Author)

Factor	Characteristic features
Building Shape	A compact building with minimal surface area
Orientation	Southern orientation
Building Envelope	Well insulated opaque envelope without thermal bridges
	Tight building envelope
	Optimum opaque envelope (wall and roof)
Insulation	Huge thermal mass and thick insulation
Apertures	Passive use of solar energy (high solar energy gains through openings)
	Large south facing windows plus small windows on the north side of the house
	Shaded apertures (shade considerations)
	Triple glazed windows
	Well insulated window frames
	Less external doors if possible
Ventilation System	Heat recovery systems
	High efficient heat recovery from exhaust air (using an air-to-air heat exchanger)
Heating System	No conventional fossil fuel central heating

Chapter 5

CONCLUSION

Due to the lack of existing resources for fossil fuels, the increase of the world population, and the constant increase of energy costs along with the fossil energy consumption problems, the consuming of fossil fuel resources must be reduced worldwide. Therefore, the passive house should be adapted to reduce energy consumption and to decrease the environmental impact, so that the users are independent from energy price increase. Nowadays, passive house is used in many European countries.

This research concluded that passive house is a viable and sustainable energy saving concept which can be used in different European countries.

The result from the passive house examples shows that the passive house is climatically suitable for different European countries and climate due to the high reduction of energy consumption for heating demand in winter for cold climate zone and cooling demand in summer for hot climate zone, for instance annual cooling demand in summer is up to 90% in Granada, annual heating demand in winter is more than 85% (Gothenburg, Hannover) and primary energy use compared with the existing building in the same countries is more than 62%.

The conducted investigation demonstrated that passive house is technologically suitable for different Europe countries, because passive houses can be built by conventional building materials, such as brick, timber etc.

According to the case studies, the passive house is economically suitable, which have only 2% to 12% additional cost investments.

This research further concluded that the codes (standards) are different in each country, because of their different climate. Standards have a great impact in reducing of energy consumption in Europe up to 50%.

The adaptation of a passive house is based on the performed analysis of a passive house considering the technical performance of building elements, weather characterizations, resource availability and other special conditions in different countries. The implementation of a passive house in different countries also includes the different boundary conditions expressed in an increased value for solar gain, air change rate for ventilation and different building structures, using suitable techniques and energy supply availability.

The compactness (A/V - ratio) is significant for cold climate zone to avoid heat loss, while appropriate openings and shading devices are significant for hot climate zone to avoid overheating of interior spaces in summer period. The cooling load for climate zone is very high in hot climate zones.

Passive house in different countries should have a high level of thermal comfort. The solution should be affordable, or it will not be attractive with conventional

technology. Insulation should be applied in all climates. Shading is also needed especially in the climates with high solar radiation in summer time. Heat recovery is necessary in all cold and in all hot climates, with a ventilation system.

REFERENCES

- Abdulsalam, E., Mehdi, M. (2011). Application of advanced glazing and overhangs in residential buildings. *ScienceDirect, Energy Conversion and Management* 52 (2011) 212–219.
- Al-Homoud, M. (2005). Performance characteristics and practical applications of common building thermal insulation materials. *Building and Environment*. 40:353–366.
- Al-Khishali, K. (2010). Energy conservation in building corresponding to human comfort. <http://www.uotechnology.edu.iq/dep-MechanicsandEquipment/Lectures%20and%20Syllabus/Lectures/Airconditioning%20and%20Refrigeration/Foruth%20Grade/Energy%20conservation%20lucture%203.pdf>.
- Al-Tamimi, N., Fadzil, S., Harun, W. (2010). The Effects of Orientation, Ventilation, and Varied WWR on the Thermal Performance of Residential Rooms in the Tropics. 4(2), 142- 149.
- American Institute of Architects. (2012). Carbon Neutral Design Strategies: Control of Solar Radiation Through Shading. *Carbon Neutral Design Strategies* project, <http://tboake.com/carbon-aia/strategies1b.html>.

- Anderson, L., Engström, A. & Lindström, G. (2012). Energy-Efficient Passive House using thermal mass to achieve high thermal comfort, REHWA Journal, January 2012.
- Assyce. (2010). Sustainable building. Energy Assyce and Energy, <http://en.assyce.com/index.php/Edificacion-sostenible/49/0/>.
- Bainbridge, D.& Haggard, K. (2011). Passive Solar Architecture: Heating, Cooling, Ventilation, Daylighting, and More Using Natural Flows. White River Junction, Vt.: Chelsea Green Pub. ISBN:9781603582964.
- Biket, A. (2006). Architectural Design Based On Climatic Data, 1st International CIB Endorsed METU Postgraduate Conference, Built Environment - Information Technologies, Ankara.
- Bodart, M., Herde, A. (2002). Global energy savings in offices buildings by the use of daylighting. Energy and Buildings 34 (2002) 421–429.
- Boqvist, A., Claeson-Jonsson, C., Thelandersson, S. (2012). Passive House Construction – What is the Difference Compared to Traditional Construction? The Open Construction and Building Technology Journal, 2010, 4, 9-16.
- Brown, G. Z., Dekay M. (2001). Sun, Wind & Light. Architectural Design Strategies. New York: John Wiley & Sones, Inc.

Bunyesc, J. (2012). Passive House in a Mediterranean Climate. 16th International Passive House Conference Hannover 04.05. – 05.05.2012.

Chenvidyakarn, T. (2007). Review Article: Passive Design for Thermal Comfort in Hot Humid Climates. *Journal of Architectural/Planning Research and Studies*, 5(1).

Constructing-Excellence. (2007). Case study: Lindås, Göteborg: Sustainable construction in the UK and Sweden.
<http://www.ukswedensustainability.org/projects/lindas.jsp>.

Construible. (2010). Passivhaus en Granada.
<http://www.construible.es/noticiasDetalle.aspx?id=6660&c=6&idm=10&pat=10>.

Elswijk, M. (2008). European Embedding of Passive Houses. Promotion of European Passive Houses (PEP)-Project Report. Energy Information Administration, <http://www.eia.doe.gov/cabs/Iran/pdf.pdf>.

Etheridge, D. (2012). *Natural Ventilation of Buildings: Theory, Measurement and Design* (3rd Edition). Wiley-Blackwell, ISBN: 047066035X, 9780470660355.

Eurostat. (2011). *Key figures on Europe*. Luxembourg: Publications Office of the European Union: ISSN 1830-7892.

- Evans, M. (2009). A Comparison of Building Energy Codes in the Asia-Pacific Region. Pacific Northwest National Laboratory, U.S. Department of Energy.
- Evcil, A. (2012). An estimation of the residential space heating energy requirement in Cyprus using the regional average specific heat loss coefficient. *Energy and Buildings* 55 (2012) 164–173.
- Feist, W. (2003). Climate Neutral Passive House Estate in Hannover- Kronsberg: Construction and Measurement Results.
http://www.passivhaustagung.de/zehnte/englisch/texte/PEP-Info1_Passive_Houses_Kronsberg.pdf.
- Feist, W. (2006). Definition of Passive Houses:Passive House Institute.
http://www.passivhaustagung.de/Passive_House_E/passivehouse_definition.html.
- Feist, W. (2006a). 15th Anniversary of the Darmstadt - Kranichstein Passive House: Factor 10 is a reality. Directory of the Informations on Passive Houses,http://www.passivhaustagung.de/Kran/First_Passive_House_Kranichstein_en.html.
- Feist, W. (2006b). Thermal Insulation of Passive Houses:Passive House Institute.
http://www.passivhaustagung.de/Passive_House_E/Passive_house_insulation.html.

Feist, W. (2007). Is it profitable to build a Passive House? Passive House Institute,
[http://www.passivhaustagung.de/Passive_House_E/economy_passivehouse.h
tm.](http://www.passivhaustagung.de/Passive_House_E/economy_passivehouse.htm)

Garde, F., Adelard, L., Boyer, H. & Rat, C. (2004). Implementations and
Experimental Survey of Passive Design Specifications Used in New Low-
Cost Housing. *Energy and Buildings*, 36 (4): 353–366.

Golunovs, J. (2009). For the passive house: www.building.lv.
http://www.building.lv/readnews_print.php?news_id=105919.

Gut, P., Ackerknecht, D. (1993). *Climate Responsive Building: Appropriate
Building Construction in Switzerland*: SKAT.

Heiduk, E. (2009). *Residential Building: Terraced / Row Houses*. 10.02_PH-
SUMMER SCHOOL,
[http://www.nachhaltigwirtschaften.at/hdz_pdf/0812_ph-
summerschool_10_02_ph_buildings_residential_terraced.pdf](http://www.nachhaltigwirtschaften.at/hdz_pdf/0812_ph-summerschool_10_02_ph_buildings_residential_terraced.pdf).

Heiselberg, P. (2006). *Design of Natural and Hybrid Ventilation*.
Aalborg University, ISSN 1901-7286.

IEA. (2007). *Energy Balances of OECD Countries*. Paris, OECD.

IEA. (2008). *Basic Program for Housing: Energy*.
<http://www.iea.org/textbase/pm/?mode=pm&id=2600&action=detail>.

- IEA. (2011). Göteborg, Sweden: Sustainable Solar Housing. International Energy Agency,
http://www.secureproject.org/download/18.360a0d56117c51a2d30800078413/1350483402278/Lind%C3%A5s_Sweden.pdf.
- IEA. (2011a). Demonstration Houses in Hannover-Kronsberg: Sustainable Solar Housing. International Energy Agency:
http://www.passivhaustagung.de/Passive_House_E/PDF/IEA28_Example_Passive_House.pdf.
- ISO 7730 (2005). Local thermal comfort criteria published by International Organization for Standardization (www.iso.org/iso/home.html)
- ISOVER. (2008). The ISOVER multi-comfort house hot climate.
http://pdf.archiexpo.com/pdf/isover-saint-gobain/multi-comfort-house-hot-climate/51881-34514-_28.html.
- ISOVER. (2013). Green facts, energy efficiency. <http://www.isover.com/Q-A/Green-facts-energy-efficiency/How-to-design-and-build-an-energy-efficient-building>.
- Janson, U. (2009). Experiences from New Swedish Passive House Projects. PLEA2009 - 26th Conference on Passive and Low Energy Architecture, Quebec City, Canada.

- Janson, U. (2010). Passive houses in Sweden: From design to evaluation of four demonstration projects. Department of Architecture and Built Environment, Lund University.
- K.S. Al-Jabri, (2005). Concrete blocks for thermal insulation in hot climate. *Cement and Concrete Research* 35 (2005) 1472 – 1479.
- Karasu, A. (2010). Concepts for Energy Savings in the Housing Sector of Bodrum, Turkey. PhD Thesis, Technique University Berlin, Germany.
- Kemal, B., Kucukali, S. (2012). Availability of renewable energy sources in Turkey: Current situation, potential, government policies and the EU perspective (Vol. 42). *Energy Policy*.
- Lam, J.C., Tsang, C.L., Li, D.H.W. & Cheung, S.O. (2005). Residential Building Envelope Heat Gain and Cooling Energy Requirements. *Energy*, 30 (7): 933–951.
- Lapithis, P. A. (2004). Passive solar design consideration for Cyprus. Intercollege-Design Department POB 2405, Lefkosia, CY 1700.
- M.Taheri, S. (1999). Energy saving by proper tree plantation. *Building and Environment* 34 (1999) 565-570.
- Mathu, V. K., Chand, I. (2003). Climatic Design for Energy Efficiency in Buildings. *IE (I) Journal-AR*, 84 (2003): 33-39.

- Mure, O. (2011). Energy Efficiency Trends in the EU: Lessons from the Odyssee-Mure Project.
- Nayak, J. (2006). Handbook on energy conscious buildings. Indian institute of technology, Bombay and Solar energy center, Ministry of non-conventional energy sources, Government of India.
- Oettinger, G. (2010). A strategy for competitive, sustainable and secure energy, The European Commission's communication 'Energy 2020'.
- Ossen, D.R., Madros, N. H. (2005). Optimum Overhang Geometry for Building Energy Saving in Tropical Climates. *Building Engineering*, 4(2): 563-570.
- Ottmar, E., Ramón, P. M., Youba, S. (2012). Energy use and environment change mitigation: Special report of the intergovernmental. Cambridge University. ISBN 978-1-107-02340-6.
- Passive House Database (2013).
<http://www.passivhausprojekte.de/index.php?lang=en>.
- Passive-On. (2007). Passive Home Training Module for Architects and Planners.
<http://www.slideshare.net/sustenergy/passive-home-training-module-for-architects-and-planners>.
- Passive-On. (2007a). Objectives of Passive-On. <http://www.passive-on.org/en/>.

Passive-On. (2007b). The passive house standard in European warm climates
(part 1). Brian Ford, Duan Zhongcheng, School of the Built Environment,
University of Nottingham.

PEP (Promotion of European Passive Houses) (2006). Passive House Solutions.
www.europeanpassivehouse.org

PHI. (2006 b). Design avoiding thermal bridges - preferable not only for Passive
Houses: Passive House Institute.
http://www.passivhaustagung.de/Passive_House_E/passive_house_avoiding_thermal_brigdes.html.

PHI. (2006 c). Insulation: Passive House Institute.
http://www.passivhaustagung.de/Passive_House_E/insulation_passive_House.html.

PHI. (2006 d). Air Tightness to Avoid Structural Damages: Passive House Institute.
http://www.passivhaustagung.de/Passive_House_E/airtightness_06.html.

PHI. (2006 e). Windows for Passive Houses: Passive House Institute.
http://www.passivhaustagung.de/Passive_House_E/PH_windows.html.

PHI. (2006f). Why a mechanical ventilation system is recommended - at least in
passive houses: Passive House Institute.
http://www.passivhaustagung.de/Passive_House_E/ventilation_06.html.

PHI. (2008). Directory Passive Houses: Europe leading the world - an Action Plan for Energy Efficiency: Realising the Potential. Intelligent Energy Europe, http://www.passivhaustagung.de/Passive_House_E/PassiveHouse_directory.html.

PHI. (2012). Passive house requirements. http://www.passiv.de/en/02_informations/02_passive-house-requirements/02_passive-house-requirements.htm.

Ram, P., David, N. L. (2010). Energy savings from tree shade. ScienceDirect, Ecological Economics 69 (2010) 1324–1329.

Ramzi ,O.A. (2007). A simplified analysis method to predict the impact of shape on annual energy use for office buildings. Energy Conversion and Management 48 (2007) 300–305.

Reardon, C., Clarke, D. (2010). Passive cooling. Australian Bureau of Meteorology, <http://www.yourhome.gov.au/technical/fs46.html>.

Roaf, S., Fentes, M., Thomas, S. (2001). Ecohouse – a design guide. London: ISBN 0 7506 4904 6.

Rosenlund, H. (2000). Climatic Design of Buildings using Passive Techniques. 10(1), 3-26.

Schnieders, J. & Hermelink, A. (2006). CEPHEUS results: Measurements and occupants' satisfaction provide evidence for Passive Houses being an option for sustainable building. *Energy Policy* 34 (2006) 151–171.

Schüller, D. (2000). Audio and video materials in tropical countries. *International Preservation News*. 21: 4-9.

Sergio, B. M. (2012). Potential energy savings from cool roofs in Spain and Andalusia. *ScienceDirect, Energy* 38 (2012) 425e438.

Stemmers, K. (2003). *Energy and Buildings*, Vol.35, p: 3- 14.

Suehrcke, H. P. (2008). Effect of Roof Solar Reflectance on the Building Heat Gain in a Hot Climate . *Energy and Buildings*, 40 (12): 2224-2235.

Tverberg, G. (2013). Ten Reasons Why High Oil Prices are a Problem.

<http://ourfiniteworld.com/2013/01/17/ten-reasons-why-high-oil-prices-are-a-problem/>.

Umar, U. A. (2013). Towards Building Energy Efficiency for Developing Countries. *Bonfring International Journal of Industrial Engineering and Management Science*, 3(2250-1096), 13 - 19.

Venmar Ventilation Inc. (2012). Indoor Air Quality Product Brochure (Vol. 244).

<http://www.inspiredliving.com/venmar-ventilation/Venmar-Ventilator-Brochure-2012.pdf>.

Watson, D., Kenneth, L. (1983). Climatic building design – energy efficient building principles and practice . McGraw Hill, New York, USA.

Wilson, L. (2013). Passive House Infographic Shows the Benefits of Building Efficient, Tightly Insulated Homes. MSc Sustainable Building, www.donau-uni.ac.at/fbs.

Wimmers, G. (2009). Passive Design Toolkit for Home. Light House Sustainable Building. Centre,UK.