

**Ergonomical Evaluation for the Design of the Computer
Laboratory PC Lab3 in the Department of Industrial
Engineering at EMU and Proposing a Better Design**

Faeza Saleh A. Dlhin

Submitted to the
Institute of Graduate Studies and Research
in partial fulfillment of the requirements for the Degree of

Master of Science
in
Industrial Engineering

Eastern Mediterranean University
June 2013
Gazimağusa, North Cyprus

Approval of the Institute of Graduate studies and Research

Prof. Dr. Elvan Yılmaz
Director

I certify that this thesis satisfies the requirements as a thesis for the degree of Master of Science in Industrial Engineering.

Asst. Prof. Dr. Gökhan İzbirak
Chair, Department of Industrial Engineering

We certify that we have read this thesis and that in our opinion it is fully adequate in scope and quality as a thesis for the degree of Master of Science in Industrial Engineering.

Assoc. Prof. Dr. Adham Mackieh
Supervisor

Examining Committee

1. Assoc. Prof. Dr. Adham Mackieh

2. Asst. Prof. Dr. Emine Atasoulu

3. Asst. Prof. Dr. Orhan Korhan

ABSTRACT

The aim of this study is evaluating both furniture and layout of the computer lab in the Industrial Engineering Department at EMU University and its effect on the student posture, performance and attention.

Fifty students were used as subjects. Their ages range between 18 to 35 years. Eleven anthropometric data of the subjects were measured including: Stature, shoulder height, shoulder elbow height, buttock popliteal length, popliteal height, knee height, forearm hand length, hip width, elbow sitting height, sitting height and eye sitting height. The mean, standard deviation, percentiles, minimum and maximum value of anthropometric dimensions were calculated.

The current layout of the lab was evaluated by observing the number of workstations, aisles, free areas available, placement of whiteboard and presentation screen. The current layout was found to fail to comply with Ergonomy design criteria.

The results from hypotheses testing showed that there are significant differences between male and female body dimensions.

A new design of furniture and a new layout for PC lab proposed to improve the level of comfort and the level of attention to lectures for students.

Keywords: Anthropometric data, Percentiles, Ergonomy design criteria, layout.

ÖZ

Bu çalışmanın amacı, Endüstri Mühendisliği DAÜ Üniversitesi Bölümü ve öğrenci duruş, performans ve dikkat üzerindeki etkisi bilgisayar laboratuvarı mobilya ve düzeni hem de değerlendirmektedir.

Elli öğrenciler denek olarak kullanıldı. Yaşları 18 ile 35 yıl arasında değişmektedir. Boy, omuz yüksekliği, omuz dirsek yüksekliği, kalça popliteal uzunluk, popliteal yükseklik, diz yüksekliği, ön kol el uzunluk, kalça genişliği, dirsek oturma yüksekliği, yükseklik oturma ve göz yüksekliği oturma: Deneklerin on antropometrik verileri dahil olmak üzere ölçüldü. Ortalama, standart sapma, yüzdelik, minimum ve antropometrik boyutları maksimum değeri hesaplanmıştır.

Laboratuar mevcut düzeni iş istasyonları, koridorlar, boş alanlar, beyaz tahta ve sunum ekranınızda mevcut düzeni yerleştirilmesi Ergonomi tasarım kriterleri uymadığınız bulunmuştur sayısı gözlemleyerek değerlendirildi.

Hipotez testi elde edilen sonuçlar kadın ve erkek kasa ölçüleri arasında önemli farklılıklar olduğunu göstermiştir.

Mobilya ve bilgisayar laboratuvarı için yeni bir düzen yeni bir tasarım konfor ve öğrenciler için ilgi düzeyi düzeyini artırmak için önerdi.

Anahtar Kelimeler: Antropometrik veriler, Yüzdelik, Ergonomi tasarım kriterleri, düzen.

TABLE OF CONTENTS

ABSTRACT	iii
ÖZ	iv
LIST OF TABLES	vii
1 INTRODUCTION	1
2 LITERATURE REVIEW	3
2.1 Design Layout	5
2.2 Workstation Design.....	9
2.3 Sitting	11
2.3.1 Sitting at a VDT Workstation.....	11
2.3.2 Monitor	12
2.3.3 Keyboard.....	13
2.3.4 Mouse	14
2.4 Mismatch Between Anthropometric Measures And Lab Furniture.	14
2.5 Illumination	16
2.5.1 Glare	17
3 METHODOLOGY	18
3.1 Subjects	18
3.2 Anthropometric Method.....	18
3.3 The Dimensions and Layout of the PC Lab	21
3.4 The Equipment Used in this Study Comprises the Followings.....	23
3.5 Data Collection.....	23
4 EXPERIMENTAL DESIGN	25

4.1 Experiment Design	25
4.2 The Normality Assumption	26
4.3 Percentile Calculation	27
4.4 Inferences about the Difference in Meaning	27
4.4.1 Hypothesis Testing	28
4.4.2 Inference on the Variances of Two Normal Population	28
4.4.3 Two-Sample t-Test Independent Samples with Equal Variance	29
4.4.4 Two-Sample t-Test with Unequal Variances.....	31
5 RESULTS AND DISCUSSION	32
5.1 Laboratory Furniture	32
5.2 Anthropometric Measurement.....	33
5.3 Evaluate the Current Furniture of the PC Lab.....	34
5.3.1 Popliteal height and seat height	34
5.3.2 Buttock-popliteal Length and Seat Depth.....	35
5.3.3 Hip width and Seat Width.....	35
5.3.4 Shoulder Height and Backrest Height	35
5.3.5 Elbow Sitting Height and Desk Height	36
5.3.6 Underneath Desk Height.....	36
5.4 Combination of Statistics and Optimization	37
5.4.2 Table Design.....	42
5.5 Designing for Adjustable Range	45
5.5.1 Test for Equal Variance	46
5.5.2 Two-Samples t-test for Independent Samples with Equal Variances.....	48
5.5.3 Two samples t-Test when Variances are Unequal.....	49

5.6 Percentages of Mismatches for New Adjustable Chair and Table.....	50
5.6.1 Requirements for Adjustable Chair	51
5.6.2 Requirement for Table Design	54
5.7 Layout Workstation Design	57
5.8 Proposal for Computer Workstation and Layout Design	62
5.8.1 The Proposed Design of computer workstation.....	62
5.8.2 The proposed layout of the computer lab.	64
6 DISCUSSION AND CONCLUSION.....	66
REFERENCES	70
APPENDICES	73
Appendix A: Anthropometric Measures of Students	74
Appendix B: Analysis of Anthropometric Measures	82
Appendix C: Results of Hypothesis Test By Minitab 14	105

LIST OF TABLES

Table 3.1: Form to Record Measurements of Students.....	23
Table 5.1: Dimensions of Furniture Used at PC lab in IE Department.	32
Table 5.2: Anthropometric Ddata for the Overall Subjects	33
Table 5.3: Mismatch between Furniture and Body Dimensions for 50 Students	36
Table 5.4: Proportion of Students Match at Different Seat Height.....	38
Table 5.5: Anthropometric Dimensions.....	40
Table 5.6: Anthropometric of EH and ES in mm	43
Table 5.7: Proportion of Match Students at Different Desk Heights.....	44
Table 5.8: Values of F_0 for Anthropometric Measurements.....	46
Table 5.9: Values of S_p And t_0 that Obtained by Excel 2007.....	48
Table 5.10: Values of t_0 when Variances are Unequal.	49
Table 5.11: Value of Degree of Freedom and $t_{\alpha} v$	49
Table 5.12: The Mismatch Between Popliteal Height and Seat Height	51
Table 5.13: Mismatch between Buttock Popliteal Height Seat Depth.....	53
Table 5.14: Mismatch between Hip Breadth and Seat Width.....	54
Table 5.15: Minitab Descriptive Statistics for Table Height.	54
Table 5.16: Table Height of Female Student	55
Table 5.17: Table Height of Male Student.....	55
Table 5.18: Minitab Two Sample t- Test for Table Height	56
Table 5.19: Dimensions of New Proposed Chair.....	63

LIST OF FIGURES

Figure 2.1: U Computer Lab Seating Arrangement.....	7
Figure 2.2: Cluster Seating Arrangement	7
Figure 2.3: Conventional Straight Row.	7
Figure 2.4: Viewing Angle Viewing Distance.....	13
Figure 2.5: The Shoulder at Flexion and Abduction.....	15
Figure 2.6: Sitting Posture at the Lower and Upper Limits of Seat Height.....	15
Figure 3.1: Measurement Illustrations by Using Instruments.....	19
Figure 3.2: Measured Anthropometric Dimensions.....	20
Figure 3.3: Furniture Dimensions A.	22
Figure 3.4: Furniture Dimensions B.	22
Figure 3.5: Instruments for Anthropometric Measurement.	23
Figure 5.1: Normal Distribution Graph with Histogram for Elbow Sitting Height.....	33
Figure 5.2: Proportion of Match Population at Different Seat Height.....	39
Figure 5.3: Proportion of Match Population at Different Seat Depth.....	41
Figure 5.4: The Optimal Proportion of Match Population at Different Desk Height.	43
Figure 5.5: Boxplot of Female and Male’s Hip Breadth	50
Figure 5.6: Individual Value Plot of Female and Male’s Hip Breadth.....	50
Figure 5.7: Posture of Student at Computer Workstation.....	52
Figure 5.8: Boxplot and Individual Value Plot of Table Height for Male and Female. ...	56
Figure 5.9: Table of Computer Workstation Lab.....	58
Figure 5.10: The Layout of Computer	58
Figure 5.11: Top View for Current Layout of Computer Laboratory Classroom.....	59

Figure 5.12: The Placement of Presentation Screen and Whiteboard.....59

Figure 5.13: The Position of Teacher’s Table.....61

Figure 5.14: Glare on Computer’s Screen61

Figure 5.15: A proposed Computer Workstation.....63

Figure 5.16: A proposed Computer Lab Layout.65

Chapter 1

INTRODUCTION

In recent decades of the twentieth century many universities are using computer labs in educational system as an approach to develop the students' knowledge in contact with the software and give them more practice that help them to apply the computer programs in their lectures and researches. Therefore, it is necessary to focus in workstation design and layout of a computer laboratory where many students spend hours in a day sitting in front of a computer performing their course-works assignments without thinking about the influence on their health.

The computer workstation can be defined as the environment around the computer system which includes the following components:

- Furniture such as seats, tables and other work surface.
- Computer equipment such as monitor, keyboard, mouse and CPU device.
- Accessories for instance document holder, footrest and Mouse Bridge.
- Environment factors as noise, illumination, glare, temperature and humidity.

Physically, the student's bodies are facing many significant stresses, without being aware of them, from extending their wrists; or slouching, or sitting without armchair and feet support or also straining to look at poorly placed monitors.

Such conditions may lead to cumulative trauma disorders or repetitive stress injuries, which can affect human health, and cause more pain, or muscular fatigue, or loss of sensation, or tingling and reduced performance.

The design of computer laboratory layout depends on the area of lab, equipment and furniture which are needed.

As we know the ergonomics as a science aims to reduce strain, fatigue, and injuries of human by improving the product design and workspace arrangement. It has always claimed a comfortable design and relaxed posture. Therefore, in the design of PC workstations, it is important to use anthropometric measures.

The dimensions needed for such a design are sitting elbow height, shoulder height, upper arm length, knee height, popliteal height, sitting eye height and buttock-popliteal length. Moreover, to assess the degree of success in product design we can determine the degree of fitness to human body dimensions which is known as ‘mismatch ratios.’

In this thesis we firstly, present a literature review about the design of the physical layout of computer classroom and workstations in chapter two. Secondly, the methodology which is used, in this study, to gather the anthropometric measurements from industrial engineering students at Eastern Mediterranean University (EMU) is presented in chapter three. Additionally, the experimental design is considered in chapter four. After that, the results are analyzed and discussed in chapter five. Finally, the ergonomic design for workstation and the layout of the PC Lab-class are proposed.

Chapter 2

LITERATURE REVIEW

Universities and Colleges have been using computer technology for more than thirty years as a tool to support the educational process. Therefore, computer laboratories have played a major base in most universities in the world to assist teaching system.

Many high schools, colleges and universities are using computer labs to teach student actually how to use the important software which is needed and to facilitate understanding lectures clearly. However, these educational institutions did not give their attention to the layout design of the lab. They usually used a simple method to construct the computer room by filling it with computers and tables in a traditional way and having the blackboard in front of the class without applying any ergonomic principles in such a design.

(Mike May) listed the considerations needed in the physical layout of the computer classroom as follows. The teacher is moving through the room from a group to another to guide the students, she/he sometimes use the blackboard or electronic screen on the wall which is in front of the room in lecturing. She/he also makes comments for all students, while the students are working on computers.

(Scott-Webber, 2000) Mentioned that, the method of communication in the classroom is determined by activities, as lecturing, sharing information, motivating, and performing demonstrations.

(Cornell, 2003) Believed that a student prefers active teaching processes because it is more actually and mentally motivating. When the students are sitting for long periods of time listening and writing lecture notes without any active learning environment, they will be less interesting, even more tired and sleepy.

Using the computer lab technology and proper software such as PowerPoint this may help instructors to create an exciting learning environment where students are more focused and paying more attention to the lessons (Callahan, 2004).

When teachers poorly communicate with students in explaining the information, the result of this would be low learning. The computer lab session allows the students to apply what they are educated in the lecture by experimenting with computer technology (Callahan, 2004).

(Tamer, 2010) made a study to evaluate instructional computer laboratories according to the physical ergonomic criteria. In this study three computer labs were chosen from different departments at Suleyman Demirel University in Turkey. Data were gathered and recorded through observations about computer labs such as the technical features of keyboard and computer monitor, physical characteristics of lighting conditions, relative humidity, temperature levels, and noise levels. Moreover, all features of desks and

chairs were recorded; It was found that the physical features of computer labs, monitor features, relative humidity and temperature levels were in agreement with the ergonomic criteria. But, tables, seats, keyboard features, and noise levels were not found to conform to the ergonomic criteria. This may have effect on students' health and the occurrence of performance problems in students' studies.

2.1 Design Layout

It is necessary to know how the design of computer lab classrooms supports the relationship between teachers and students and how the design of computer laboratories supports learning and teaching system.

(Callahan, 2004) Listed that, the classroom environment is affected by some physical factors as the followings:

- (1) Dimensions such as room, aisles, ceiling heights and door widths.
- (2) Entrances such as door location.
- (3) Windows such as, placement and treatments.
- (4) Finishes such as walls, ceilings and floors.
- (5) Furnishings and equipment as instructor's desk, display surface, student seating.
- (6) Heating system and air Conditioning.
- (7) Lighting.

(Mike May) Specified the design requirements for the computer classroom as follows:

1. Students must be able to see both their own computer screens and the teacher's presentation screen without changing their places. Therefore the style of classroom will be arranged in a traditional row model.
2. The designers' team wanted several students to see the same screen while the instructor is explaining at the white board without any need for the students to move from their places. As a result they decided to use a screen on top of the table instead of one's sunk into desktops.
3. The teacher's computer screen can be fixed onto the front wall or put on the front of the whiteboard.
4. In addition, with respect to their experience in teaching in computer labs, they wanted the students to share activities so they should be sit in group forms such as each 4 students with 2 computers. This lead to a decision to put desks together so each four students would be sit at an extended desk with two of computers in the center of the table.
5. Moreover, the space between tables should be enough for the instructor to freely move throughout the lab while students are working.

(Nicolas, 2007) recommended for the space where no furniture are available, an area of 50 cm in front of any window , an area of 3m in front and 1m at both sides of the main entrance door of the room and an area of 50 cm around any radiator. Additionally as related to the free area around the workstation as passages around them, as well as for unobstructed sitting and reaching to the seat they suggested an area of 55 cm along the front side of the desk, an area of 50 cm along the entry side of the workstation, an area

of 75 cm along the back side of the desk for seat side, and an area of 100 cm along the back side of the desk if there is a storage area behind the desk.

(Callahan, 2004) Suggested that “the computer lab must be prepared with a presentation system, audio system, and network connections.” Additionally, all computer labs need mobile chairs, and more flexible seating arrangements. Accordingly, there may be three common arrangements of labs; U seating arrangement as shown in figure (2-1), clusters of computer's arrangement as shown in figure (2-2) and parallel row shape as illustrated in figure (2-3) .

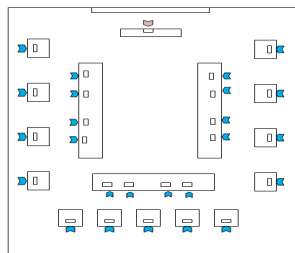

Figure 2.1: U Computer Lab Seating Arrangement

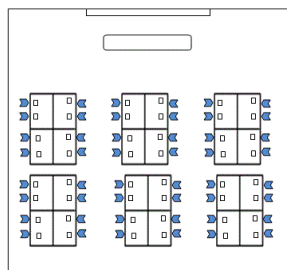

Figure 2.2: Cluster Seating Arrangement

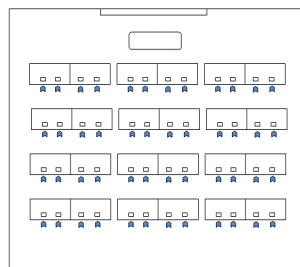

Figure 2.3: Conventional Straight Row

In the traditional classroom there are some factors that influence on functional place arrangement such as the nature of student activities, instructor's teaching methods, the physical dimensions and shape of the room (Sommer, 1967). The advantage of the computer lab classroom with U shape that it gives to the presenter sight of all of the students' computers. It is more beneficial for computer courses that use teaching methods as, lecture, group discussion, and presentation. The cluster seat model is similar to the straight row classroom layout. The main difference between them is the tables of computer are put in vertical shape to the front of the room in the cluster seating arrangement as illustrated in figure (2-2). This layout is the best for small groups and team work. The conventional straight row layout shown in figure (2-3) is a standard for a lecture classroom. This design consists of some rows that are parallel to the front of the classroom. This layout enhances the collaboration between the students. However, in this arrangement the instructor is not able to see the students' computer screens during the lecture (Callahan, 2004).

(Sommer, 1967) Concluded the followings. In the seminar-style room, the most of students around the teacher are participating more than other students. Additionally, the students of the straight row arrangement who are near the front and middle of the classroom are participating more than the students at the back and sides of the classroom.

In this study I will propose the layout of the PC computer laboratory in Industrial engineering department. First I will identify the important elements, for the design of the layout of a computer laboratory, such as the number of students, area of classroom,

furniture, presentation system, aisles, entrance, and windows. Next, I will evaluate the current PC Lab design and determine the problems that may be facing the students during lab sessions. Finally, I will propose a new design for PC Lab with more facilities and flexibility that should support both students and teachers and enhance the students' participation during lecturing.

As we know, students spend many hours each day in front of the computer screen without thinking about the health impact of the related human posture. A physical stress may result on human bodies from sitting incorrectly at a workstation staring to the computer screen for a long period of time with no rest, or from using chairs without armrest or backrest etc.... The symptoms from such postures may be eye strain fatigue, or/and cumulative trauma or/and repetitive stress injuries that affect negatively the performance. This project focuses on the proper workstation design to reduce visual and musculoskeletal discomfort.

2.2 Workstation Design

Subjects that are concerned in the design of computer workstation are; Monitor placement, keyboard, work surface adjustability, chair design, foot rests, wrist rests, lighting and ease of adjustability. The poor design of these subjects (mentioned above) may result in physical disorders which are known as Musculoskeletal Disorders (MSD's) that may show up as (Sweere, 2002):

- Eye strain and headache.
- Neck and back fatigue.
- Wrist and shoulder diseases.

(Ashraf, 2007) made a study on 40 workstations to identify ergonomic deficiencies in computer workstation design by physical measurements and a questionnaire. As a result they found, eyestrain 58% , shoulder pain 45% , back pain 43% , arm pain 35% , wrist pain 30% , and neck pain 30% . These results indicated serious ergonomic disorders in office computer workstation design , layout, and usage. Therefore, they suggested providing the computer workstations in the offices by ergonomics standards guidelines, and recommendations. Additionally, they found out that employees must be trained in ergonomic layout to organize themselves their workstations.

(Timoteo-Afinidad, 2010) analyzed the workstation of Filipino users. Their considerations were health problems due to the present design, percentage fitting of current design, and the postures of the workers. They concluded that the current workstation design does not fit the average Filipino users. Additionally, the increase in the number of injuries during work due to the wrong dimensions and poor workspace design may lead to unsatisfactory motivational needs. Moreover, the use of uncomfortable workstation caused the increase of the probability of errors at work and reduced the performance of workers. Therefore, they recommended some immediate solutions as placing the back cushion for lower back support to avoid back pains and when the chairs used are made of wood the seat and back cushion should be used. Additionally, the monitor should be placed in front at a distance of 50 cm.

(Angsumalin, 2010) evaluated a desk-seat set that are used at Chulalongkorn University. By using applied statistics with optimization, they found as a result that 9% of users are matching with seat height and 36.3% of users are matching for desk height.

Additionally, they concluded that the most convenient heights both for seat and desk were (40.5 cm and 62 cm) instead of (47.7 cm and 75 cm) which were currently used. These proposed new dimensions would increase the percentage of matching to 63.4% for seat height and 98% for desk height.

2.3 Sitting

When users are sitting, tilting forward on a seat, a higher loading of the intervertebral will be occurred. This is occurring due to decreasing of the hip angle and would influence the breathing ability and Blood Circulation (Dowler, 1998).

The benefit of chair arms is to assist in unloading the spine as the body weight shifts to the facet joints and causing an elongation of height, as compared to the standard seated position, and therefore the discs would be unloaded (Callahan, 2004).

Backrests should be adjustable in tilting at least 85 degrees to 100 degrees while still it is possible to maintain at least a 90 degree sitting angle and have the adjustability for height between 16 to 20 inches from the seat pan. Additionally, it should be at least 13 inches wide (EOHSS, 2008).

2.3.1 Sitting at a VDT Workstation

The chair is the most commonly used piece of equipment of a computer workstation. In such a workstation where users spend many hours of their time sitting, it is necessary to select a proper adjustable chair and enable the users to sit comfortably and work efficiently by providing a suitable support to minimize fatigue (EOHSS, 2008).

The chair height should allow the workers to rest their feet on the floor or on a footrest. Additionally, it should allow the worker to use a suitable keyboard while keeping her/his forearm parallel to the floor and her/his wrists at the same plane of the forearm, and his/her legs should have enough clearance(Callahan, 2004). The optimal adjustability range for seat height is recommended to be 37cm to 55cm (Healthcare Ergonomics, 2003-2012).

(Min Yong, 2000) Made a study by using three dimensional human modeling tools to design a new chair which satisfies the anthropometric specifications for Korean population. They designed a workstation chair that fits the 5th percentile female Korean and the 95th percentile male Korean. They constructed the mock-up chair, where the seat pan can be moved up and down by as much as 20 cm. The height of the tray can also be adjusted up to 15 cm. The tray swings 180 around the pole connected to metal beam on the right side of the seat pan and slides forward and back by 20 cm. This designed new chair, when attached with a keyboard and mouse, decreased muscle activity and made subjects feel more comfortable than when using the conventional chair.

2.3.2 Monitor

The monitor is a necessary component of a computer workstation, the important factors needed to determine the placement of the monitor are viewing angle and viewing distance as shown in figure (2-4).

- 1- Viewing angle: indicate to the scale upper or lower of the horizontal line at the level of the user's eyes.
- 2- Viewing distance: refers to the dimension between the user's eyes and the screen.

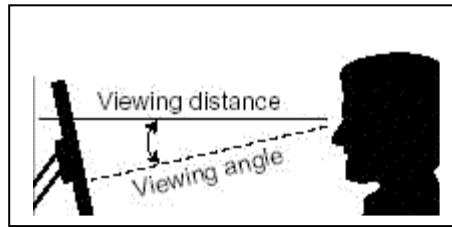

Figure 2.4: Viewing Angle Viewing Distance

The screen placement has an important effect on the neck movement, if the angle is incorrect this would cause both neck and shoulder discomfort. When the distance is not proper this can cause eyestrain. On the other hand the position of the document holder relative to screen placement should be at the same distance and as close together as possible from the eyes so, the user can see from one to another with no movement of his neck or back (EOHSS, 2008). The best viewing distance for VDTs is the range from 18 to 24 inches as equivalent (45.72 to 60.96 centimeters, respectively) (EOHSS, 2008).

Hedge and Powers declared, the best comfortable level of the screen distance was recorded when the position of the monitor is at 79 cm away from the worker. A range of screen distances between 6 to 93 cm was proposed earlier by Grandjean. The range of optimal visual angles between 15° to 22° was proposed by Cormick and Sanders (Dowler, 1998).

2.3.3 Keyboard

Keyboard should be comfortable for the operator, separate and adjustable to make proper position, and correct angle. The ideal working position for keyboard user is the posture where forearms are parallel to the floor and elbows at the sides of the body, so it allows the hands to work softly and easily on the keyboard. The wrist must be at the

same line level of the forearm. When the keyboard is very high or very low awkward wrist, arm, and shoulder postures would result. Performing keying tasks in awkward postures such as these can result in hand, wrist, and shoulder discomfort (EOHSS, 2008).

2.3.4 Mouse

The mouse is a pointing device in a computer workstation. It should be put at the user's side closer to the worker's body. Additionally, a straight line between the hand and forearm should be maintained (EOHSS, 2008).

2.4 Mismatch Between Anthropometric Measures And Lab Furniture

The mismatch can be defined as the incompatibility between student's body dimensions and the dimensions of laboratory furniture's.

In this study we will calculate the mismatch between popliteal height and seat height, buttock popliteal length and seat depth, hip width and seat width, elbow sitting height and desk height, shoulder height and backrest height, knee height and table clearance .

(Gouvali, 2006) defined a mismatch between popliteal height and seat height when the current seat height is less than the cosine of thirty degree or greater than the cosine of five degree of popliteal height.(Parcells, 1999) Determined the mismatch between seat depth and buttock popliteal length when the seat depth is less than 80% or greater than 95% of buttock popliteal length (Castellucci, 2010). As presented in (Gouvali, 2006) the mismatch between seat width and hip breadth occurs when the seat width is less than 1.1 or greater than 1.3 of hip width, and the backrest height as recommended to keep the backrest lesser than the scapula height, or at the upper edge of the scapula 60–80% of

shoulder height. Hence, the mismatch appears when the backrest is greater than 0.8 or less than 0.6 of sitting shoulder height.

(Parcells, 1999) Recommended the table clearance should be at least 20 mm; this space allows the knees to be more comfortable under the table. He proposed the desk height should be designed to elbow- floor height. Therefore the lowest table height we will get it when the shoulders are not in flexion or abduction. When the shoulders are at 25° flexion and 20° abduction the table height will be at the maximum elevation as shown in figure (2-5).

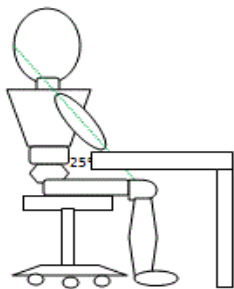

Figure 2.5.A: The Shoulder at 25° Flexion

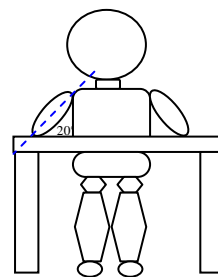

Figure 2.5.B: The Shoulder at 20° Abduction

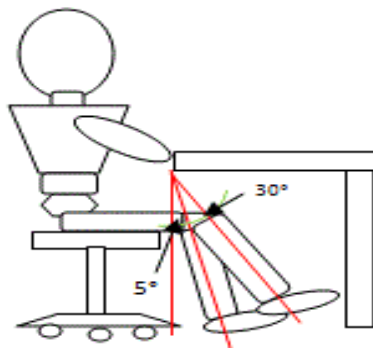

Figure 2.6: Sitting Posture at the Lower and Upper Limits of Seat Height

Thus, we can conclude the lowest desk height as following :

Min desk height = Elbow sitting height + low seat height

$$\text{Min DH} = \text{EH} + \cos 30^\circ \text{PH} \quad (2-1)$$

When; EH = sitting-elbow height, and DH = desk height

The maximum desk height can be calculated from

$$\text{Max DH} = \text{Max SH} + \text{Max EH}$$

$$\text{Max DH} = \cos 5^\circ \text{PH} + \text{Max EH} \quad (2.2)$$

Let AL is arm length then, AL = sitting shoulder height – elbow sitting height.

$$\text{AL} = \text{SDH} - \text{EH} \quad (2.3)$$

Where SDH is the shoulder sitting height

$$\text{Then, Max EH} = \text{EH} + (1 - \cos 20^\circ) \text{AL} + (1 - \cos 25^\circ) \cos 20^\circ \text{AL}$$

$$\text{Max EH} = \text{EH} + 0.0604 \text{AL} + 0.0881 \text{AL} \quad (2-4)$$

Given (2.2) and (2.4)

$$\text{Max DH} = \cos 5^\circ \text{PH} + 0.852 \text{EH} + 0.148 \text{SDH} \quad (2-5)$$

Thus, from (2.1) and (2.5), formula to determine DH is

$$\text{EH} + \cos 30^\circ \text{PH} < \text{DH} < \cos 5^\circ \text{PH} + 0.852 \text{EH} + 0.148 \text{SDH} \quad (2.6)$$

2.5 Illumination

In many fields of our lives we need sources of light which can be from the sun as daylight or from artificial sources such as overhead light. The amounts of lighting we need to complete our jobs depend on type of jobs. So, when a person works some activities on indoor or at night, it is necessary to provide him with some source of illumination whether from natural daylight or from artificial sources (McCormick, 1992).

Students are usually seating in front of a monitor for one hour or more this may have some effects on their vision. They often focus on the computer screens for long periods of time. This may cause the strain in muscles of their eyes and possibly they may feel headache and fatigue.

The glare and the intensity of light are the main factors that may have an effect on the eye strain. When a student read and write by using a computer in a poor lighting environment, he will feel muscle soreness and fatigue in his eyes. For instance, the student might tilt forward in low lighting environment to see her/his screen clearly, or tilt to backward to avoid the glare coming from either her/his screen or a bright light overhead. Improving the lighting, adjustment the height of workstation, taking time to rest and using eyeglasses during computer work, may help to solve many computer-related vision problems (EOHSS, 2008).

2.5.1 Glare

Glare is difficulty of vision due to the presence of bright light, whether from the sunlight or artificial sources or reflex surfaces. It is necessary to avoid glare as much as possible because it affects the performance of work. To avoid glare from windows, the curtains can be adjusted to reduce the amount of light on your screen. Additionally, we should sit beside or in parallel to the window while we face the monitor. Moreover, to avoid glare from overhead lights we should adjust the angle of computer screen (WorkSafeBC, 2009).

Chapter 3

METHODOLOGY

3.1 Subjects

A total of fifty undergraduate and postgraduate students, twenty-three males and twenty-seven females were participated in this study. Their ages ranged from eighteen to thirty-five years old. All subjects were students from EMU University.

3.2 Anthropometric Method

Anthropometry is an active field in industrial design, ergonomics and architecture where statistical data about the distribution of body dimensions in the population are used to improve products. Changes in life styles, nutrition and physical differences between global population lead to changes in the distribution of body dimensions, and require regular updating of anthropometric data collections.

In this research, eleven anthropometry dimensions were measured and directly used in designing chairs and tables for students' computer workstations. All anthropometric measurements were collected using the students of Industrial Engineering Department at EMU. During measurement each student was asked to keep two different postures; sitting up right where knees and elbow bent at ninety degrees as in figure (3-1), and standing erect without shoes. The measurements weight was done using a balance such as shown in the figure below.



Figure 3.1: Measurement Illustrations by Using Instruments

The measured dimensions were height, shoulder height, shoulder elbow height, buttock popliteal length, popliteal height, knee height, forearm hand length, hip width, elbow sitting height, sitting height and eye sitting height figure (3-2) shows all these dimensions. On the average, it took around 10 minutes to complete all the measurements required per one student.

The descriptions of human body dimensions which are recorded in this research are as follows:

1. Stature (or height): It is the vertical distance taken from the floor to the highest point of the head when the student stands erect and looking straight ahead.
2. Shoulder height: Is defined as the vertical distance from the top of the shoulder at the acromion to the subject's sitting plane or seat pan.

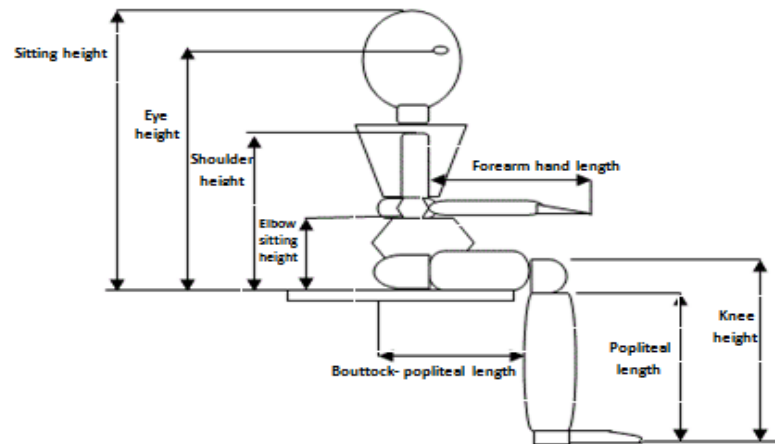
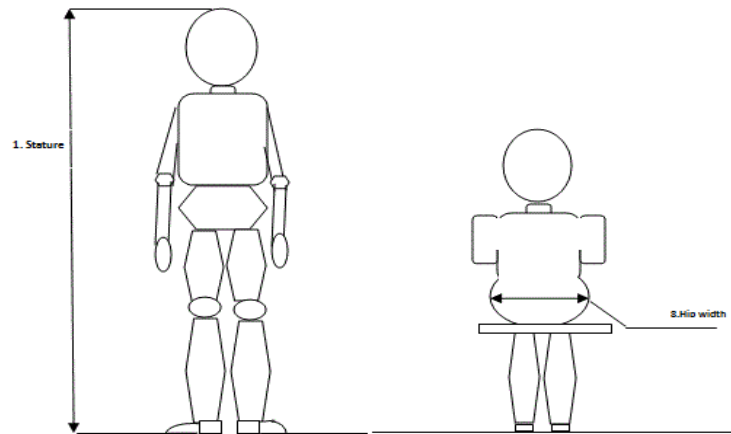

Figure 3.2: Measured Anthropometric Dimensions

3. Shoulder elbow length: Is referring to the difference between the elbow sitting height and shoulder height.

4. Buttock-popliteal length: When the student sitting with 90° knee flexion, the buttock-popliteal length is the horizontal distance from the posterior surface of the buttock to the posterior surface of the knee or popliteal space.

5. Popliteal height: Popliteal height is the vertical dimension, with 90° knee flexion, from the foot resting surface to the posterior surface of the knee or popliteal surface.
6. Knee height: Knee height is the vertical distance, with 90° knee flexion, from the foot surface to the top of the kneecap.
7. Forearm hand length: is the horizontal distance from the elbow to fingertip.
8. Hip width: is the maximum horizontal distance across the hips in the sitting surface.
9. Elbow sitting height: It is measured as the vertical distance from the bottom of the tip of the elbow, with 90° elbow flexion, to the subject's seated surface.
10. Sitting height: is the vertical distance from the tip of the head to the surface of the sitting object.
11. Eye height: is the vertical distance from the sitting surface to the landmark on the outer corner of the right eye.

3.3 The Dimensions and Layout of the PC Lab Including Furniture's Measurements

After the anthropometric measurements of students were taken the second stage of this study is to determine the followings:

1. Total square area of lab.
2. Number of workstations used.
3. The places of equipment which are used for teaching processes such as presentation screen and whiteboard.
4. Furniture dimensions for both seat and table's workstation.
5. Locations of workstations relative to the instructor's screen and whiteboard.

6. Number and dimensions of aisles which are used in present layout.

7. Locations of the windows and the entrance.

8. The student posture while he is sitting at his workstation.

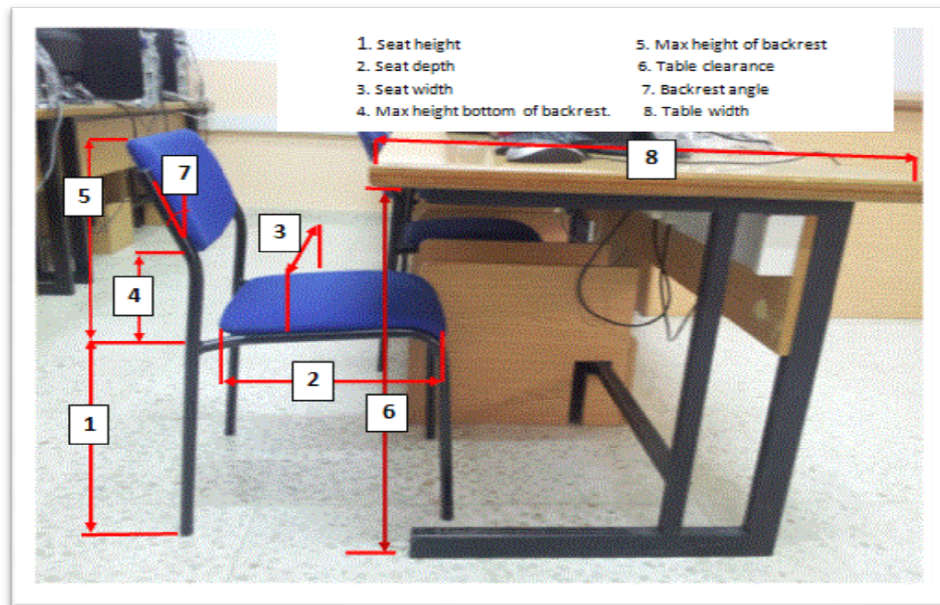

Figure 3.3: Furniture Dimensions A.

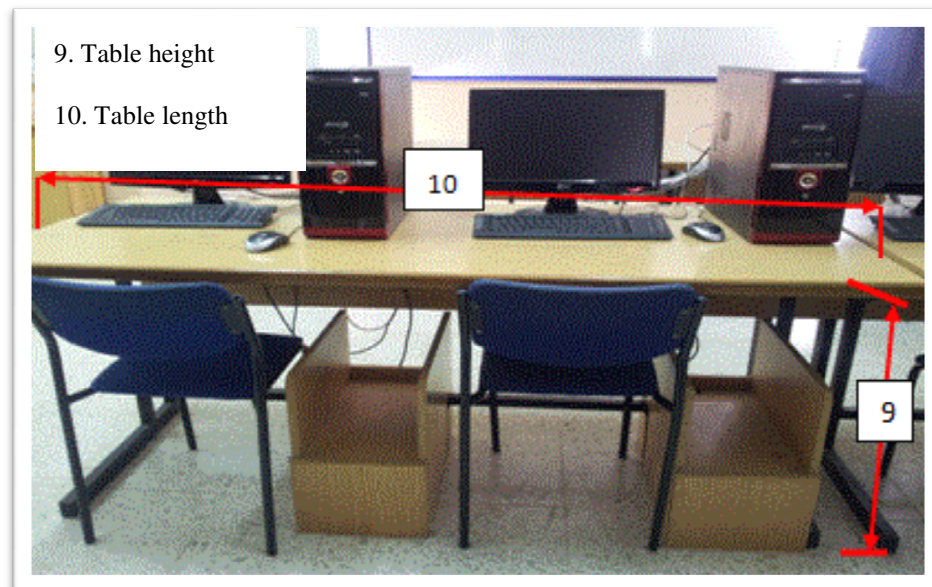

Figure 3.4: Furniture Dimensions B.

3.4 The Equipment Used in this Study Comprises the Followings

1. Anthropometer ruler.
2. Metal tape.
3. Angle finder.
4. Balance.



Figure 3.5: Instruments for Anthropometric Measurement.

3.5 Data Collection

The dimensions measured should be documented in a form, which includes some personal information such as name, age, sex, and student number. Each Student must fill her/his own personal information before the measurement process started. Table3-1 shows clearly the exact location for all eleven anthropometric dimensions, which is important to ensure the measurement process for each student is done correctly and accurately and to minimize the errors in the data collection process.

Table 3.1: Form to Record Measurements of Students

Subjects	1	2	50
Name				
Student number				
Gender				
Age				
Weight kg.				
Height				
Shoulder height				
Shoulder elbow height				
Buttock popliteal height				
popliteal height				
knee height				
Forearm length				
hip width				
Elbow sitting height				
Sitting height				
Sitting height				
Sitting eye height				

Chapter 4

EXPERIMENTAL DESIGN

4.1 Experiment Design

Experimental design is a statistical procedure used to improve processes, where the process variables are studied and its final result shows to experimenter which variables are most important and which are insignificant.

In this research we consider the experiment to compare between two conditions that usually are named treatments. For example, the popliteal height of student is an important characteristic of the seat height design. Therefore, the designer is interested in comparing the popliteal height of males and females. In this project we need to compare between the pair of treatment (male and female) for all anthropometric dimensions of students such as height, shoulder height, shoulder elbow height, buttock popliteal length, popliteal height, knee height, and hip width that used in workstation design.

An experiment was designed and performed as follows. First, 50 students (or subjects) were randomly selected. Then we use anthropometric set to measure the dimensions of students' body. Subjects were randomly scheduled to measurement. Additionally, the order of measurement of specific dimensions was randomized.

A completely randomized design was used in this research. The averages of all anthropometric measurements, male and female, were calculated and hypotheses were formulated and tested.

4.2 The Normality Assumption

Before applying statistical methods that suppose normality, it is necessary to perform a normality test on the anthropometric body dimensions. The normality assumptions are easy to check by using a normal probability plot. Generally, we can perform it quickly by Minitab 14 .Minitab 14 gives a p-value so; we can compare this value with our stated alpha level which is equal to 0.05.

The null hypothesis states that, the anthropometric data of male and female students follow a normal distribution. We will reject the null hypothesis when the p-value is less than alpha level. As can be seen from Minitab output, the p-value is larger than 0.05, this implies there is no sufficient evidence to reject the null hypothesis and it is concluded the data distribution is normal. Additionally, as illustrated in figure (4.1) all observations are close to the straight line on the graph. Hence, the null hypothesis about normality is verified.

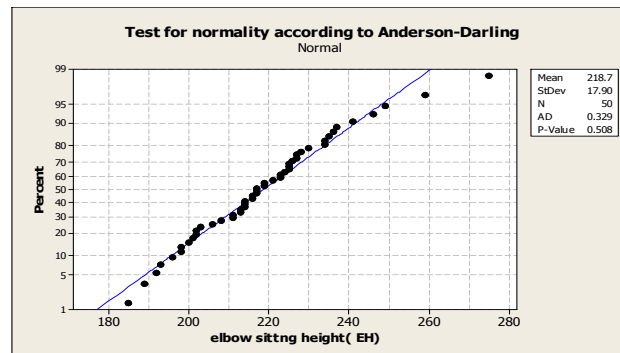

Figure 4.1: Normal Probability Plot of Elbow Sitting Height

To be noted that the normality tests for all other dimensions that are collected in this research can be seen the figures in appendix C from figure (C-18) to figure (C -26).

4.3 Percentile Calculation

The formula below is used to compute percentiles of a normal distribution.

$$K^{\text{th}} \text{ percentile} = \mu \mp z \sigma \quad (4-1)$$

Where μ is the mean of anthropometric dimensions which are (height, shoulder height, shoulder elbow height, buttock popliteal length , popliteal height, knee height, forearm hand length, , hip width , elbow sitting height , sitting height and eye sitting height figure) and σ is their standard deviation and Z is the value from the standard normal distribution for the wanted percentile. If we take any human body dimension such as elbow sitting height, we will find the 5th and 95th percentiles as follow:

$$5^{\text{th}} \quad P_{\text{Elbow sitting height}} = \mu_{\text{Elbow sitting height}} - 1.65 * \sigma_{\text{Elbow sitting height}}$$

$$95^{\text{th}} \quad P_{\text{Elbow sitting height}} = \mu_{\text{Elbow sitting height}} + 1.65 * \sigma_{\text{Elbow sitting height}}$$

The average (μ) and the standard deviation (σ) of a human body dimension can be taken from the table (5-2).

4.4 Inferences about the Difference in Meaning

Comparison between the different genders of students starts by investigating and determining whether males and females have equal body dimensions. So hypothesis will be formulated and tested by using the data collected in this experiment.

4.4.1 Hypothesis Testing

The method of statistical inference used is named hypothesis testing or significance testing. It is used to discover whether males and females are having equal mean body dimension or not. Let $y_{f1}, y_{f2}, \dots, \dots, y_{fn_f}$ represent the dimensions recorded from n_f female students, and $y_{m1}, y_{m2}, \dots, \dots, y_{mn_m}$ represent the dimensions recorded from n_m male's students. The main assumption here is the collected measurements are normally distributed.

- **Statistical Hypothesis**

It is a statement about the distribution parameters.

$$H_0: \mu_f = \mu_m$$

$$H_1: \mu_f \neq \mu_m$$

Where μ_f and μ_m denote the, mean of a specific measured dimension for females and male respectively. The statement of null hypothesis H_0 implies that both females and males have equal mean in term of the specific recorded body measurement. Where the statement of alternative hypothesis implies H_0 is not true.

4.4.2 Inference on the Variances of Two Normal Population

Consider two populations male and female students to be compared. Let n_f denoted the sample size of female students and n_m denote the sample size of male populations. Let Y'_f and S_f denote the sample mean and standard deviation from female students and Y'_m and S_m denote the sample mean and standard deviation from male. Then the test statistic that can be used to test the equality of the female and male variances is:

$$F_0 = \frac{S_f^2}{S_m^2} \tag{4-2}$$

The test statistic follows the F distribution with degrees of freedom $\nu_f = (n_f - 1)$ and $\nu_m = (n_m - 1)$ for male and female respectively.

1. The statements for this hypothesis as:

$$H_0: \sigma_f^2 = \sigma_m^2$$

$$H_1: \sigma_f^2 \neq \sigma_m^2$$

2. Let the significance level $\alpha = 0.05$. Here the test statistic is based on the F distribution where $n_f = 27$ and $n_m = 23$.

Given that $\nu_f = 26$ and $\nu_m = 22$ then, the null hypothesis H_0 is rejected if the test statistic F_0 is such that:

$$F_0 > F_{0.025,26,22}$$

$$F_0 < F_{0.975,26,22}$$

Note that the table gives only upper-tail percentage of F. Thus, we can find the value of $F_{0.975,26,22}$ by this formula.

$$F_{0.975,26,22} = \frac{1}{F_{0.025,26,22}}$$

3. The value of the test statistic F_0 corresponding to the given data is:

$$F_0 = \frac{S_f^2}{S_m^2}$$

By using Excel 2007 we can compute the value of F_0, t_0, v for all parameter or by using statistical software packages Minitab 14.

4.4.3 Two-Sample t-Test Independent Samples with Equal Variance

One of the most common statistical testing methods is the two sample t-test used for comparing the means of two populations.

The general setting is as follows: Consider two populations to be compared in terms of a particular variable. Let n_f , μ_f , σ_f , n_m , μ_m and σ_m denote the sample size, mean and standard deviation of a specific recorded body dimension for the female and male subjects respectively. The hypothesis of the test is

$$H_0: \mu_f = \mu_m$$

$$H_1: \mu_f \neq \mu_m$$

The anthropometric measurements which have equal variances make sense to pool all the data from both female and male to estimate the common variance by the following formula

$$S_p^2 = \frac{(n_f-1)s_f^2 + (n_m-1)s_m^2}{n_f + n_m - 2} \quad (4-3)$$

The degrees of freedom for the pooled variance estimator is $n_f + n_m - 2$.

Thus,
$$v = 27 + 23 - 2 = 48$$

The test statistic for the hypothesis test is simply the standardized difference between the sample means:

$$t_0 = \frac{\bar{Y}_f - \bar{Y}_m}{S_p \sqrt{1/n_f + 1/n_m}} \quad (4-4)$$

By using the Excel 2007 and Minitab 14 we can calculate the value of t_0 and p-Value.

4.4.4 Two-Sample t-Test with Unequal Variances

This section describes the testing procedure for equality of means when the assumption of equality of population variances in the two populations is violated.

$$H_0: \mu_f = \mu_m$$

$H_1: \mu_f < \mu_m$ Reject the null hypothesis H_0 if $t_0 < -t_{0.05,v}$	$H_1: \mu_f > \mu_m$ Reject the null hypothesis H_0 if $t_0 > t_{0.05,v}$
---	--

The testing procedure is the same as before except the original test statistic is modified to be

$$t_0 = \frac{\bar{Y}_f - \bar{Y}_m}{\sqrt{s_f^2/n_f + s_m^2/n_m}} \quad (4-5)$$

$$v = \frac{\left(\frac{s_f^2}{n_f} + \frac{s_m^2}{n_m}\right)^2}{\frac{(s_f^2/n_f)^2}{n_f - 1} + \frac{(s_m^2/n_m)^2}{n_m - 1}} \quad (4-6)$$

Chapter 5

RESULTS AND DISCUSSION

5.1 Laboratory Furniture

The computer laboratory in the Industrial Engineering department under study consists of forty chairs and twenty tables. Only one type of chair and table exists in the lab and their dimensions are as shown in table 5-1 below.

Table 5.1: Dimensions of Furniture Used at Computer Workstations in IE Department.

Dimensions	Measurement
Seat Height (cm)	40
Seat Depth	39
Seat Angle	3°
Backrest angle	10°
Seat width	37
Max height of backrest	36.5
Max height to bottom of backrest	14.5
Desk height	74
Desk clearance	71
Desk slop	0
Desk width	180
Desk length	75

5.2 Anthropometric Measurement

The measurements of the students' bodies are listed in table 5-2 below. Analysis of data was done by Excel 2007 and Minitab 14. Basic descriptive statistics were used to compute both mean, median, standard deviation, maximum and minimum value for anthropometric data. As you can see in table 5-2, most of the means and medians are very close to each, indicating symmetrical distributions.

We can calculate the 5th and 95th percentile by using formula (4-1). If you take any dimension from table (5-2) such as sitting elbow height, you can see the average for all students is 218.58mm with a standard deviation of 17.45 mm, where the standard deviation value is directly proportional to the difference between each data and the mean.

Let: mean = μ Standard Deviation = σ

5th percentile = $\mu - 1.65 \sigma = 218.68 - (1.65 \times 17.89) = 189.16\text{mm}$.

95th percentile = $\mu + 1.65 \sigma = 218.68 + (1.65 \times 17.89) = 248.2\text{mm}$.

These distributions of sitting elbow heights seems to be normally distributed as you can see from figure (5.1).

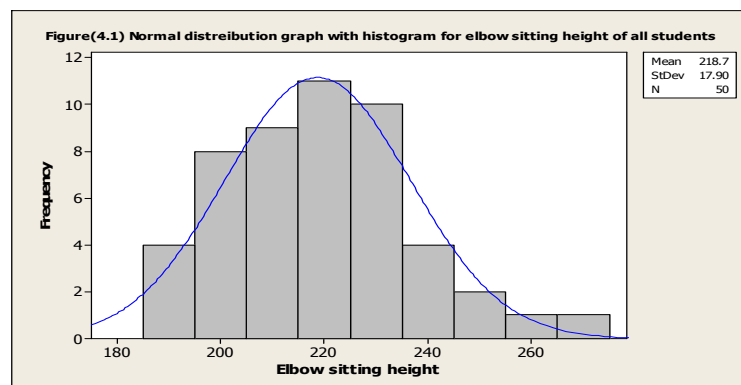

Figure 5.1: Normal Distribution Graph with Histogram for Elbow Sitting Height

Table 5.2: Anthropometric Data for the Overall Subjects

Dimension	μ	Median	σ	Max	Min	5th	95th
Weight kg.	69.43	65.25	14.214	115	47	45.976	92.883
Height mm	170.38	170.75	8.405	185	148	156.511	184.24
Shoulder height	535.28	539	26.23	584	472	492.00	578.56
Shoulder elbow height	316.6	317	23.37	371	258	278.03	335.16
Buttock popliteal height	460.2	453.5	22.28	518	425	423.44	496.96
Popliteal height	430.6	432	20.21	465	385	397.24	463.95
Knee height	514.6	511.5	26.78	564	448	470.42	558.78
Forearm length	455.02	455	25.39	502	385	413.12	496.92
Hip width	384.58	375	38.1	467	314	321.73	447.43
Sitting elbow height	221.4	223	17.42	240	154	189.16	248.2
Sitting height	813	820.5	52.32	896	670	726.67	899.33
Sitting eye height	728	733.5	51.31	804	585	643.33	812.67

5.3 Evaluate the Current Furniture of the PC Lab

For evaluation and redesign of the laboratory furniture, it is important to consider the applied of anthropometry and ergonomics principles, and use equations to calculate the limitations of furniture dimensions to determine the mismatch.

5.3.1 Popliteal height and seat height

(Gouvali, 2006) Presented the match criterion as the following:

$$PH \cos 30^\circ < SH < PH \cos 5^\circ \quad (5-1)$$

When PH = popliteal height

SH = seat height

Therefore the mismatch occurs when the current seat height is less than $\cos 30^\circ$ or greater than $\cos 5^\circ$ of popliteal height.

5.3.2 Buttock-popliteal Length and Seat Depth

Most designers recommended that, seat depth should be designated for the 5th percentile of the popliteal buttock length distribution. Poulakakis and Marmaras (1998) suggested that depth should be at least 5 cm shorter than popliteal buttock length. (Parcells, 1999) determined the mismatch when the seat depth was $\leq 80\%$ or $\geq 95\%$ of buttock popliteal length (Castellucci, 2010).

$$0.80PB \leq SD \leq 0.95PB \quad (5-2)$$

5.3.3 Hip width and Seat Width (SW)

The seat width must be large enough to provide accommodation for the users with the largest hip. To reduce the mismatch between hip width and seat width the seat width should be design at the 95th percentile of hip width distribution or the largest hip (Gouvali, 2006) proposed a modified equation (5-3).

$$1.1HW \leq SW \leq 1.30HW \quad (5-3)$$

As you see from equation (5-3) the mismatch occurs when the seat width is less than 1.1 or greater than 1.3 of hip widths.

5.3.4 Shoulder Height and Backrest Height

The backrest height recommended by (Gouvali, 2006) as keeping the backrest lesser than the scapula height, or at the upper edge of the scapula (60–80% of shoulder height).

$$0.6 SDH \leq BH \leq 0.8 SDH \quad (5-4)$$

Thus the mismatch appears when the backrest is greater than 0.8 or less than 0.6 of sitting shoulder height.

5.3.5 Elbow Sitting Height and Desk Height

Elbow sitting height is the important dimension to determine the table height so that, the most researchers considered it as the major criterion for desk height (Parcells, 1999) reported that the desk height should be designed to elbow- floor height. Therefore the lowest table height we will get it when the shoulders are not in flexion or abduction, but when the shoulders are at 25° flexion and 20° abduction the table height will be at the maximum therefore, the criteria of a mismatch as in equation (2-6).

$$EH + \cos 30^\circ PH < DH < \cos 5^\circ PH + 0.852EH + 0.148SDH$$

5.3.6 Underneath Desk Height (Table Clearance)

Table clearance is indicated to be the space between the knees and the underneath surface of the desk. (Parcells, 1999) recommended the table clearance should be at least 20 mm. This space allows the knees to be more comfortable under the table.

$$UD \geq 20 + \text{knee height} \tag{5-6}$$

By using equations mentioned above from (5-1) to (5-6) we can determine the mismatch for all subjects as illustrated in table (5-3).

Table 5.3: Mismatch between Furniture and Body Dimensions for 50 Students

Mismatch	Overall students	male	female
Mismatch between popliteal height and seat height	22%	26%	18%
Mismatch between Buttock popliteal height and seat depth	14%	26%	4%
Mismatch between hip width and seat width	56%	56.5%	55.5%
Mismatch between sitting elbow height and table height	92%	87%	96.3%
Mismatch between Knee height and table clearance	0%	0%	0%

The objective of this study is to evaluate the design of PC lab in the Industrial Engineering Department by using the mismatch ratio. So, we proposed two techniques to design the tables and chairs of workstations. In each technique the design is based on the optimal proportion of matching. After that, the two designs will be compared and the best workstation model will be selected. Additionally, a proposed ergonomical design for the computer laboratory (i.e. PC Lab) at the department of Industrial Engineering will be developed.

5.4 Combination of Statistics and Optimization

The aim of this technique is to design the table and chair with respect to the maximum percentage of matching between target population's body dimensions and the furniture set.

5.4.1 Chair Design

The chair is the most important piece of furniture used in a computer workstation where the student spends one hour or more of their time sitting in front of the computer workstation. Therefore, it is necessary to select a properly designed chair to enable the student to sit comfortably, work efficiently, and provide proper support for the human body to minimize fatigue.

- **Seat Height (SH)**

After many years of investigations a number of recommendations and guidelines are offered so that it can be used in the design of a seat. From equation (5-1).

$$SH > 0.866PH \quad \& \quad SH < 0.996PH$$

$$\text{Then, } \frac{SH}{0.996} \leq PH \leq \frac{SH}{0.866}$$

Thus, the population whose body dimension matches with current seat height of (400 mm) is:

$$\frac{400}{0.996} \leq PH \leq \frac{400}{0.866}$$

Thus, $401.6 \leq PH \leq 461.9$

When we refer to table (5-2), we can see the mean value of popliteal height for 50 students is 430 mm and the standard deviation is 20.21.

$$\text{Proportion match of population} = P\left(\frac{401.6-430}{20.21} \leq \frac{PH-\mu}{\sigma} \leq \frac{461.9-430}{20.21}\right)$$

The proportions of population match = $P(-1.16 \leq Z \leq 2.18) = 0.82$

As a result the current seat height is fitting for 82% of the students.

To optimize this percentage we will calculate this proportion for different seat heights.

The proportion of students match (are seen in the table 5- 4 below) at different seat heights:

$$P\left(\frac{\left(\frac{SH}{0.996}\right)-430}{20.21} \leq Z \leq \frac{\left(\frac{SH}{0.866}\right)-430}{20.21}\right).$$

Through varying the seat height from 400 mm to the different values between 330 and 480 mm, then the proportion of match is increased when the seat height is reduced from 480 to 400 mm. Then this proportion starts decreasing and gets closer to zero when the seat height approximately 330mm. With the optimization method, the maximum proportion of match population is found at 82% when the seat height is 400mm therefore; the current seat is more convenient for the most students and should remain the same (chair at 400mm height). This is obvious from looking at figure (5-2).

Table 5.4: Proportion of Students Match at Different Seat Height

SH	SH/0.996	SH/0.866	P1	P2	P2-P1
330	331.325	381.0624	0	0.01	0.01
350	351.406	404.157	0	0.1	0.1
360	361.446	415.7044	0	0.23	0.23
365	366.466	421.4781	0	0.33	0.32
375	376.506	433.0254	0.01	0.55	0.54
380	381.526	438.7991	0.01	0.66	0.65
385	386.546	444.5727	0.02	0.76	0.73
390	391.566	450.3464	0.04	0.84	0.79
395	396.586	456.1201	0.08	0.9	0.818
400	401.606	461.8938	0.12	0.94	0.82
405	406.627	467.6674	0.19	0.97	0.78
410	411.647	473.4411	0.27	0.98	0.71
415	416.667	479.2148	0.37	0.99	0.62
420	421.687	484.9885	0.48	1	0.51
430	431.727	496.5358	0.7	1	0.3
450	451.807	519.6305	0.95	1	0.05
470	471.888	542.7252	1	1	0
480	481.928	554.2725	1	1	0

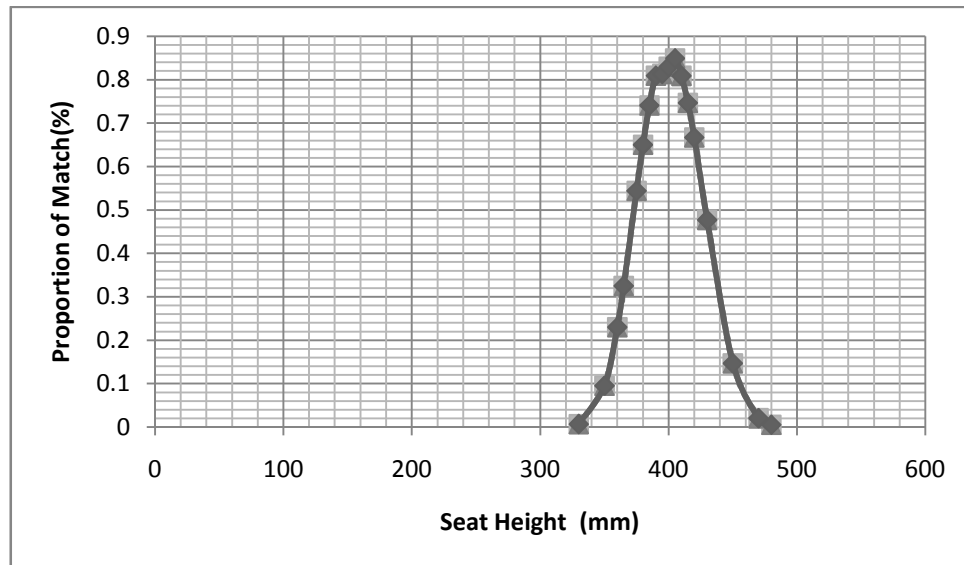

Figure 5.2: Proportion of Match Population at Different Seat Height.

- **Seat Depth (SD)**

(Gouvali, 2006) Mentioned that, most researchers recommended the seat depth should be designated for the fifth percentile of the popliteal buttock length distribution, including the shorter user. Poulakakis and Marmaras (1998) found the depth of the seat should be at least 5 cm shorter than the popliteal buttock length. Whereas, (Parcells, 1999) determined the mismatch in this case when the depth is less than 80% or greater than 95% of the popliteal-buttock length as in equation (5-2).

$$0.80PB \leq SD \leq 0.95PB$$

We can calculate the proportion of the matching students for the seat depth by using the same procedures that are explained above.

$$SD > 0.80PB \quad \& \quad SD < 0.95PB$$

Where SD is seat depth and PBL is popliteal buttock length.

$$\text{Then, } \frac{SD}{0.95} \leq PB \leq \frac{SD}{0.80}$$

Table 5.5: Anthropometric Dimensions

Body dimension	(μ) & (σ)
Buttock popliteal (PBL)	460.2 (22.28)

Thus, students whose body dimension of PBL are between 393.9 and 487.5 mm they are matching the current seat depth with 88.8% of students. If we compute the proportion at different seat depths as shown in figure (5-3) and appendix table (B-8) we see that, the maximum proportion of match population is 97.12% when the seat depth is 410 mm.

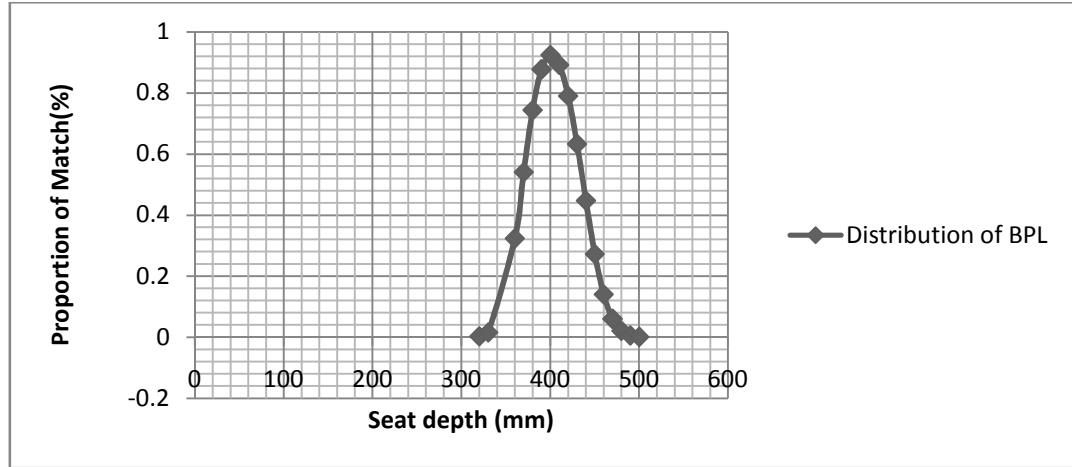

Figure 5.3: Proportion of Match Population at Different Seat Depth

- **Seat Width (SW)**

(Gouvali, 2006) mentioned that, seat width should be large enough to allow space for side movements.

From equation (5-3) then,

$$1.1HW \leq SW \leq 1.30HW$$

The proportions of match for any different seat width = $P\left(\frac{\left(\frac{SW}{1.3}\right) - \mu}{\sigma} \leq \frac{PH - \mu}{\sigma} \leq \frac{\left(\frac{SW}{1.1}\right) - \mu}{\sigma}\right)$

Once again use the same procedures to find the proportion of matching the seat width so, with referee to the table (B-10) and figure (B-3) in Appendix B we found the maximum percentage of matching is 62.7% when seat width is 460mm.

- **Backrest Height (B)**

The equation recommends keeping the backrest lower than the scapula, or at most on the upper edge of the scapula (60–80% of shoulder height) by (Gouvali, 2006).

$$0.6SDH \leq BH \leq 0.8SDH \tag{5-4}$$

So; $BH \geq 0.6SDH$ and $BH \leq 0.8SDH$

Thus, $\frac{BH}{0.8} \leq SDH \leq \frac{BH}{0.6}$

Referring to the table (B-9) and figure (B-2) in Appendix B the maximum proportion of match population is 99.96 when the backrest height is 365 mm.

5.4.2 Table Design

As people with different heights perform different tasks, the computer desk should be designed to minimize stressful posture. To estimate the proportion of students matching the current table height, we can apply the same procedures which we used earlier to determine the proportion of matching of students for seat height. From table (5-1) the current desk height DH is 740 mm. From equation (2-6) that mentioned in section 2-4 the limitations of desk height are:

$$EH + \cos 30^\circ PH < DH < \cos 5^\circ PH + 0.852EH + 0.148SDH$$

$$\text{Let , } ES = 0.852 EH + 0.148 SDH \quad (5-7)$$

$$DH > EH + 0.866 PH,$$

$$EH < DH - 0.866 PH \quad (5-8)$$

When PH is the current seat height a 400mm,

$$\text{Then, } EH < 740 - (0.866 * 400)$$

$$EH < 393.6 \text{ mm.}$$

$$DH < 0.996 PH + ES,$$

By substituting (5-7) in (2-6) we get:

$$ES > DH - 0.996 PH \quad (5-9)$$

$$\text{When PH is the current seat height at 400mm, then } ES > 740 - (0.996 * 400)$$

$$\text{Or } ES > 341.6 \text{ mm}$$

From the above calculations we can note the followings, the percentage of students who fit the current table height is approximately 100% (for sitting elbow height less than

393.6 mm). On the other hand it is 0% for ES greater than 341.6 (Refer to table (5-7) and figure (5-4)).

According to the formula (5-8) and (5-9) we can find the match proportion (Table 5-7) at different table heights.

The proportion of the EH at different table height = $p \left(z \leq \frac{(DH-346.4)-218.58}{17.42} \right)$ and

The proportion of ES at different table height = $p \left(z \geq \frac{(DH-398.4)-265.4}{17.48} \right)$.

Table 5.6: Anthropometric of EH and ES in mm

Body dimension	Average, (std.dev.)
Elbow sitting height (EH)	218.58, (17.42)
(ES)	265.54, (17.48)

As you see in the table (5-7) if we change the desk height from 740 mm to 620 mm, we will find the proportion of match is 99.9% when EH is less than 273.6 mm. The proportion of match is 99% when ES is greater than 221.6 mm. As a result we will record the maximum point of the percentage of matching (as 99%) at the intersection point between two curves of EH and ES. As seen in Fig.5-4 when the desk height is 620 mm.

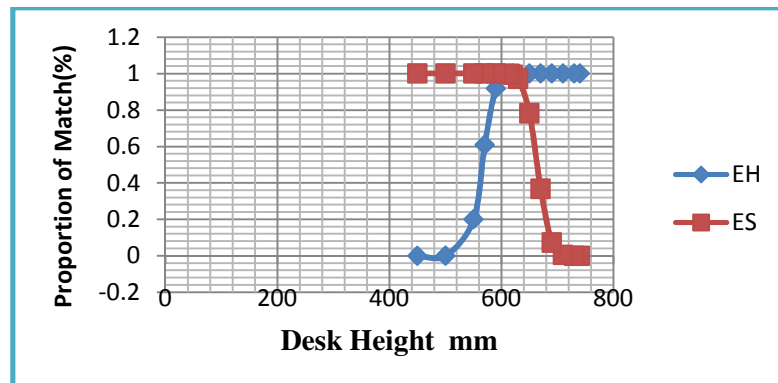

Figure 5.4: The Optimal Proportion of Match Population at Different Desk Height.

Table 5.7: Proportion of Match Students at Different Desk Heights

	DH	EH ≤ DH - 346.4	P1	ES ≥ DH - 398.4	P2	1-P2
Current table height →	740	393.6	1	341.6	1	0
	730	383.6	1	331.6	1	0
	710	363.6	1	311.6	0.99	0.01
	690	343.6	1	291.6	0.93	0.07
	670	323.6	1	271.6	0.63	0.37
	650	303.6	1	251.6	0.22	0.78
	630	283.6	1	231.6	0.03	0.97
Optima table height →	620	273.6	0.999	221.6	0.01	0.99
	615	268.6	0.997	216.6	0	1
	610	263.6	0.994	211.6	0	1
	590	243.6	0.918	191.6	0	1
	570	223.6	0.608	171.6	0	1
	550	203.6	0.2	151.6	0	1

▪ **Underneath Desk Height (Table Clearance)**

(Parcells, 1999) recommended that, the table clearance should be at least 20 mm, while (Gouvali, 2006) documented that both of Poulakakis and Marmaras (1998) Suggested at least 50 mm of clearance. According to Corlett and Clark (1995) and Helander (1997), this space should be provided to allow for knee of workers crossing and feel more comfort table. Therefore, desk-knee clearance must be exceeded by 20 mm (Gouvali, 2006).

From equation (5-6) in section 5-3-6

$$UD \geq 20 + \text{knee height.}$$

$$KH \leq UD - 20 \tag{5-9}$$

Current desk clearance (UD) = 710 mm.

From (5-9) then, knee height ≤ 710 - 20 ≤ 690

Hence, KH ≤ 690

The populations of students whose body dimension matches with current table clearance (710 mm) are the population who's KH (knee height) is less than 690mm. The maximum proportion of match is found at 100% when the desk clearance 710 mm. See table (B-11) and figure (B-4). However, the desk clearance must be adjusted to 590 mm which is lower by 30 mm than the new height of the table.

As a result, the chair and table dimensions, by this technique, should be as following:

Seat height = 400mm, Seat width = 460mm, Seat depth = 410 mm,
Backrest height = 365mm, Table height = 620 mm.

The mismatch from this method was recorded as following:

Mismatch between popliteal height and seat height is $\frac{11}{50} = 0.22 = 22\%$

Mismatch between Buttock popliteal height and seat depth is $\frac{6}{50} = 0.12 = 12\%$

Mismatch between hip width and seat width is $\frac{2}{50} = 0.04 = 4\%$

Mismatch between sitting elbow height and table height is $\frac{5}{50} = 0.10 = 10\%$

5.5 Designing for Adjustable Range

The workstation should be adjustable for the users who work many hours a day. For example the perfect table of computer workstation which consists of two levels of adjustability for height, one for the screen and another for the keyboard and mouse. The monitor usually should be 50-60 cm wide to give a suitable work space for the screen. On the other hand, most users don't have an ideal computer desk so that. When the computer tables aren't adjustable it becomes important to have adjustable seat and a keyboard tray.

The percentile is a common concept in the ergonomic design which classifies data into groups. For each population, such as male and female, dimensions are sorted and described as percentiles. The 5% always indicates the smallest fifth percentile of the specific dimension of design. For more details on percentile definitions and calculations please refer to Appendix B table (B-1). The 5th percentile to the 95th percentile range gives approximately 90% of the population who are matching the design of the product.

In this study we will determine the adjustable dimensions of workstations that are needed in the computer laboratory of Industrial Engineering Department at EMU. Therefore, we can decide which part such as, seat height , backrest height , seat depth and table height in our design needs to be adjusted and any part to be fixed.

5.5.1 Test for Equal Variance

Considering the experimental design and hypothesis test with 95% confidence interval that mentioned in section (4-2-2) to examine the differences in the variance of anthropometric dimensions between male and female students .The test statistic follows the F distribution with ($n_f - 1 = 26$), and ($n_m - 1 = 22$) degrees of freedom where, the results shown in table (5-8).

The critical F-values are $F_{0.025,26,22} = 2.315$ and $F_{0.025,22,26} = 2.25$

$$F_{0.975,26,22} = \frac{1}{F_{0.025,22,26}} = \frac{1}{2.25} = 0.44$$

$$F_{0.975,26,22} = 0.44.$$

The criteria for rejection is $2.315 < F_0 < 0.44$.

Table 5.8: Values of F_0 for Anthropometric Measurements

Dimensions	Y'_f	S_f	S_f^2	Y'_m	S_m	S_m^2	F_0
Stature	165.7	7.815	61.0742	175.91	5.089	25.9009	2.35798
Shoulder height	521.44	24.59	605.061	551	17.50	306.530	1.97390
Buttock popliteal length	451.19	17.41	303.282	470.91	22.91	525.005	0.57767
Popliteal height	422.5	18.57	344.844	440.48	17.69	312.936	1.10196
Knee height	501.5	25.88	669.774	529.96	18.67	348.568	1.92149
Hip width	394.518	43.74	1913.97	372.9	26.56	705.858	2.71155
Elbow sitting height	217.63	19.12	365.5744	219.9	16.689	278.5227	1.312548

From table (5-8) and also from the computer output of Minitab 14 table (C- 1) and table (C-8) to test for equal variances we can observe the following :

- The values of F_0 , stature = 2.357989 and F_0 , hipwidth =2.711556 are in the rejection region.
- ($P_{\text{Stature-Value}}=0.045$) and ($P_{\text{Hip breadth-Value}}=0.02$) are less than 0.05. So that, null hypothesis should be rejected. This result shows there is no evidence to indicate that, the variances of height and hip breadth for male and female are equal.
- Values of F_0 for (Shoulder height, Shoulder elbow height, Buttock popliteal height, Popliteal height and knee height) are located in the acceptance region. As can be seen from P-values (obtained using Minitab 14) for these dimensions are 0.109, 0.196, 0.181, 0.824, 0.124 respectively which are greater than 0.05. So, we cannot reject the null hypothesis and we conclude that, the variances of these anthropometric dimensions between male and female are equal.

5.5.2 Two-Samples t-test for Independent Samples with Equal Variances

According to the result in section 5-5-1 the variances of both shoulder height, Shoulder elbow height, Buttock popliteal height, Popliteal height and knee height are equal, then we apply the second test to verify the differences between means of male and female. T-test applies to the students' dimensions with $\alpha = 0.05$ and degrees of freedom for the pooled variance estimator is $v = 27 + 23 - 2 = 48$.

Table 5.9: Values of S_p and t_0 that Obtained by Excel 2007

Dimensions	Y'_f	S_f	S_f^2	Y'_m	S_m	S_m^2	S_p^2	S_p	t_0
Shoulder height	521.44	24.59	605.1	551	17.51	306.5	468.23	21.639	-4.81
Shoulder elbow height	303.8	21.06	443.5	331.6	16.01	256.4	357.77	18.915	-5.18
Buttock popliteal height	451.19	17.4	303.2	470.9	22.91	525	404.91	20.122	-3.45
Popliteal height	422.5	18.57	344.8	440.48	17.69	312.94	330.22	18.172	-3.48
knee height	501.5	25.88	669.77	529.96	18.67	348.56	522.56	22.86	-4.38
Elbow sitting height	217.63	19.12	365.57	219.9	16.68	278.52	325.67	18.05	-0.44

The critical t-value: $t_{0.025,48} = 2.010$. From table 5-9 we find that;

- The absolute values of t_0 for all students' dimensions except elbow sitting height are greater than 2.0105 and as illustrated in appendix C p-value less than 0.05 hence, H_0 should be rejected and we conclude that the means of male and female's body dimensions are different. Thus, we should focus on these differences carefully, during the design phase.
- The elbow sitting height has t_0 equal to - 0.443 and its absolute value is less than 2.0105 and p-value from appendix C Table (C-16) is 0.658 greater than 0.05 therefore, we can't reject the null hypothesis so, the means of elbow sitting height for male and females are equal .

5.5.3 Two samples t-Test when Variances are Unequal.

Variances of male and female of both height and hip width are not equal; therefore, we will use this test as shown in the following table.

Table 5.10: Values of t_0 when Variances are Unequal.

Dimension	Y'_f	S_f	S_f^2	Y'_m	S_m	S_m^2	$Y'_f - Y'_m$	$\frac{S_f^2/27}{+ S_m^2/23}$
Height	165.7	7.815	61.07	175.91	5.09	25.91	-10.21	3.389
HW	394.52	43.75	1913.98	372.913	26.57	705.86	21.605	101.58

Dimension	$\sqrt{S_f^2/27 + S_m^2/23}$	$t_0 = \frac{Y'_f - Y'_m}{\sqrt{S_f^2/27 + S_m^2/23}}$
Height	1.841	-5.54683
HW	10.08	2.143658

The table below illustrates the calculations of the degree of freedom and $t_{\alpha, v}$ for students' body dimensions such as height and hip width and equation (4-9) in section 4-2-4 was used.

Table 5.11: Value of Degree of Freedom and $t_{\alpha, v}$

Dimension	$(S_f^2/27 + S_m^2/23)^2$	$\frac{(S_f^2/27)^2}{26}$	$\frac{(S_m^2/23)^2}{22}$	$\frac{(S_f^2/27 + S_m^2/23)^2}{26 + 22}$	v	$t_{\alpha, v}$
Height	11.4794768	0.196795	0.057644	0.254439	45.117	1.678
Hip width	10317.98208	193.2732	42.81117	236.0844	43.705	1.681

From the outputs of computer Minitab 14 in appendix (C) the p-values of hip breadth and stature are 0.038 and zero respectively. Both are less than 0.05, which is in conformance with results in table 5-10 and table 5-11. Thus, we conclude the null hypothesis H_0 should be rejected and we can say, the mean height of the female is less than the mean height of male. Additionally, we found the mean of female's hip breadth

is less than the mean of male's hip breadth. This is clearly shown in Boxplot and individual value plot of hip breadth's male and female in figures (5-5) & (5-6).

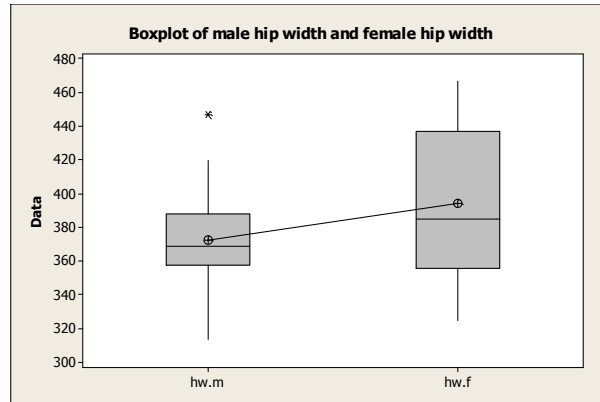

Figure 5.5: Boxplot of Female and Male's Hip Breadth

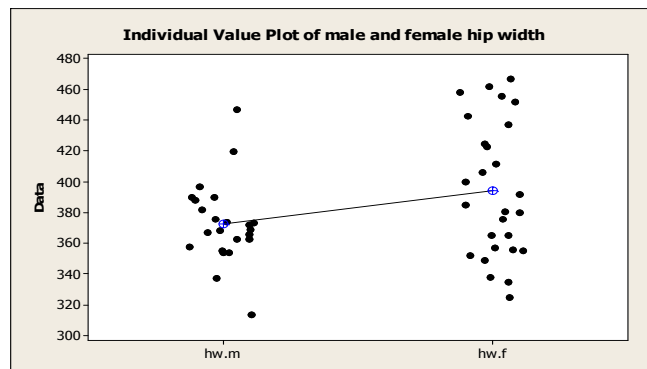

Figure 5.6: Individual Value Plot of Female and Male's Hip Breadth

As a result, it is necessary to design adjustability furniture for workstation of computer laboratory to reduce mismatch as low as possible. The mismatch of the current furniture was illustrated in table (5-3) and appendix (B-3).

5.6 Percentages of Mismatches for New Adjustable Chair and Table

5.6.1 Requirements for Adjustable Chair

I. Seat Height

The new seat height of the chair can be designed adjustable from 391.5mm to 470mm. This data was taken from 5th percentile of female student popliteal height in table (B-6) and 95th percentile of male student popliteal height in table (B-4). This allows the students to place their feet on the floor. This new seat height will reduce the mismatch from 22% to 4% for all 50 students; table (5-12) shows the mismatch between PH and SH. However the mismatch by optimization technique does not change and remained 22%.

Table 5.12: Mismatch Between Popliteal Height and Seat Height of Old and New Chair.

Mismatch	Overall students	Male	Female
Mismatch between popliteal height & SH for old chair	22%	26%	18%
Mismatch between popliteal height & SH for new	4%	0%	7%

II. Armrest Chair

The armrest chair was designed as high as 218.58mm, which is parallel to the floor. This dimension was taken from average of overall students' sitting elbow height from table (5-2) since, there isn't difference between male and female s' elbow sitting height as we have seen earlier in section 5-5-2. For this reason we are taken the average of all students. So, the wrist can be placed flat on the table and in the same plane as the forearm.

III. Backrest Chair.

The current backrest it was too low for student as illustrated in figure 5-7.



Figure 5.7: Posture of Student at Computer Workstation

The maximum edge of the backrest can be found by equation (5-4)

$$\text{Max backrest} = 0.8 \times \text{SDH} = 0.95 \times 584 = 467.2 \text{ mm}$$

The value of SDH is taken from the maximum value of male's shoulder height as the largest value to keep the backrest at the upper edge of the scapula of all students. We can find the lowest point of the backrest by calculating the thigh clearance, with reference to the data in table (B-4) and (B-6). The thigh clearance can be computed by subtracting the 5th percentile of female popliteal height from the 95th percentile of male knee height as follows: Thigh clearance = 560 - 385 = 175 mm. This gives more comfort for the lower back.

IV. Seat Depth

Seat depth could be designed as recommended as the fifth percentile of popliteal buttock length of female. This would include the shorter users. So, from equation (5-2), when

the 5th percentile for buttock popliteal length of female students is 422.34 is taken from table (B-6).

$$\text{Max seating depth} = 0.95 \times \text{BPL} = 0.95 \times 422.34 = 401.223 \text{ mm}$$

Table 5.13: Mismatch Between Buttock Popliteal Height Seat

Dimension	Male and female	Male	Female
Mismatch between Buttock popliteal height & SD of current chair	14%	26%	4%
Mismatch between Buttock popliteal height & SD of proposed chair	4%	8%	0%

As a result the mismatch will be reduced from 14% to 4% for all students where as the mismatch ration by optimization technique reduced to 12%. In addition, we will get the same results if we are designed according to average as follows. From table (5-1) the mean of BPL of over all subjects is 460mm, and from equation (5-2) the range of match is:

$$368 \leq \text{BPL} \leq 437$$

Then, the average value between the maximum and minimum limits is:

$$\frac{437+368}{2} = 402.5 \text{ mm}$$

Therefore, the seat depth is 402.5mm is the best value, where it is compatible with the most students and the mismatch is reduced.

V. Seat Width.

The seat width should be large enough to accommodate the users with the largest hip width therefore, it is designed at 467mm this dimension was taken from for the maximum value of hip width in table (5-2) for all students so, the mismatch will be eliminated but, the optimization method reduced it to 4%.

Table 5.14: Mismatch Between Hip Breadth and Seat Width

Dimension	Male and female	Male	Female
Mismatch between hip width & seat width	56%	56.5%	55.5%
Mismatch for proposed chair	0%	0%	0%

5.6.2 Requirement for Table Design

I. Table Height.

The current tables of computer workstations are very high as you see in figure (5-7). Parcels (1999) had suggested that the table height should be adjusted to elbow height measured from the floor then, we can say the table height on the average could be as :

$$\text{Table height} = \text{Popliteal height} + \text{Sitting elbow height.}$$

From hypothesis testing the results show there are significant difference between male and female students dimensions. So, if we propose two types of tables one for male and another for female so we will be able to improve the compatibility for both genders.

$$\text{Let Table height}_{\text{Female}} = \text{Popliteal height}_{\text{Female}} + \text{Sitting elbow height}_{\text{Female}}$$

$$\text{Table height}_{\text{Male}} = \text{Popliteal height}_{\text{Male}} + \text{Sitting elbow height}_{\text{Male}}$$

Tables (5-16) and (5-17) display the table heights for all subjects that are participated in this research. Then we can compute the mean value and standard deviation for desk height by using Minitab 14 as shown in table (5-15).

Table 5.15: Minitab Descriptive Statistics for Table Height.

Descriptive Statistics: (table height) _f , (table height) _m								
Variable	N	N*	Mean	SE Mean	StDev	Minimum	Maximum	
(Table height-female)	27	0	639.81	5.23	27.20	592.00	707.00	
(Table height- male)	23	0	660.39	6.18	29.64	606.00	737.00	

Table 5.16: Table Height of Female Student

PH	SEH	DH	PH	SHE	DH	PH	SEH	DH
461	246	707	420	192	612	420	236	656
422	224	646	433	202	635	429	226	655
439	234	673	423	206	629	426	241	667
432	259	691	443	201	644	395	249	644
417	198	615	389	227	616	389	235	624
415	211	626	412	213	625	451	200	651
407	196	603	407	185	592	433	221	654
427	214	641	432	203	635	434	228	662
385	214	599	419	198	617	439	217	656

Table 5.17: Table Height of Male Student

PH	SEH	DH	PH	SEH	DH	PH	SHE	DH
437	227	664	433	211	644	430	217	647
408	216	624	441	219	660	463	230	693
413	193	606	452	214	666	461	202	663
443	225	668	431	208	639	465	223	688
420	189	609	462	275	737	460	217	677
432	219	651	435	223	658			
438	225	663	435	234	669			
461	237	698	448	225	673			
455	216	671	408	213	621			

As a result the desk height of male students is higher than the desk height of female students this appears from hypothesis test as given in table (5-18) the P- value is less than 0.05. Therefore, the null hypothesis should be rejected and conclude that, the mean of table height for males is greater than the mean of female's table height (as you can see in figure (5-8)). Thus, it is very important to design more convenient table for both genders female an male.

Table 5.18: Minitab Two Sample t- Test for Table Height

Two-Sample T-Test and CI: (table height) _m , (table height) _f					
Sample	N	Mean	StDev	SE Mean	
1	23	660.4	29.6	6.2	
2	27	639.8	27.2	5.2	

Difference = mu (1) - mu (2)
 Estimate for difference: 20.5800
 95% lower bound for difference: 6.9778
 T-Test of difference = 0 (vs>): T-Value = 2.54 P-Value = 0.007 DF = 45

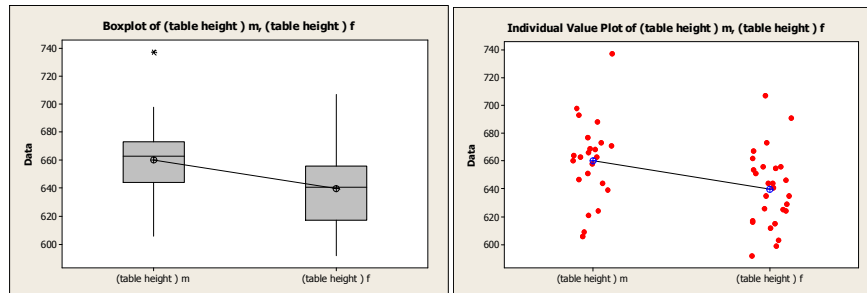

Figure 5.8: Boxplot and Individual Value Plot of Table Height for Male and Female

Therefore, if we propose two types of tables one for males with height 661 mm and another for females with height 640 mm, this would minimize the mismatch for males and females from 87% and 96.3% to 13% and 11.1% respectively. However, this method could be impractical because the number of males and females vary every semester so that, it is better if we suggest table height with the lowest average at 639.41mm. At that time, the mismatch will be reduced for male and female to 4.3% and 11.1% respectively, and the mismatch for all fifty students using the PC Laboratory will be reduced from 92% to 8%. On the other hand the optimization technique reduced the mismatch to 10%.

The design of adjustable table according to (Gouvali, 2006) needs to calculate the maximum and minimum limits of table height as follows:

$$EH + [(PH + 2) \cos 30^\circ] \leq DH \leq [(PH+2) \cos 5^\circ] + (EH \cdot 0.8517) + (SDH \cdot 0.1483)$$

The EH, PH and SDH are mean values of sitting elbow height, popliteal height and sitting shoulder height which are taken from the table (5-2).

$$593.3116 \leq DH \leq 696.2556024$$

By this calculation the desk height is recommended to be adjustable from 593.3 mm to 696.5mm therefore, the mismatch will be eliminated.

5.7 Layout Workstation Design

The computer laboratory classroom in the Industrial Engineering Department has dimensions of 820 cm wide and 1350cm length. Its area is around 110.7 square meters.

During the study of the computer lab's layout we recorded these following results:

1. Workstations where conventional straight row style where all workstations are arranged as rows which are parallel to the front of the laboratory classroom.
2. As mentioned before the laboratory consists of 20 tables and 40 chairs. Each table consists of two workstations as shown in figure (5-9), where the workstations are arranged on both sides of the lab. On each side there are five rows of workstations while each row has four workstations as shown in figure below



Figure 5.9: Table of Computer Workstation Lab



Figure 5.10: The Layout of Computer

3. The total number of workstations in the lab is 40 workstations, if we compare this number with the number of students using the lab in each group; we will find that, the number of the workstations is too large respect to the number of students. Through our questions for teachers in the department, their answers were, the average number of students in the computer lab classroom doesn't exceed 25 students in each group. So, there are more workstations than required in the laboratory.
4. There is a presentation screen with dimensions of 300 cm wide and 180 cm long. It is placed at the front of the lab with 210 cm high on the wall above the main entrance and it is facing directly the students who sit on the left side of the laboratory. The distance from screen to the front row of workstations is 240 cm

as illustrated in figure (5-11) and (5-12). In addition it is very high and close to the students who sit in the first row, which can lead to some injuries and pain in the neck. However, the students who sit on the right side of the lab, they need to move and change their posture to be able to view the screen well.

5. The current position of the presentation screen could cause the lack of concentration for the students during a lecture, when anybody enter or leave the lab.
6. The whiteboard is placed on the front right side of the lab at a distance 465 cm from workstations which are on the same side in the first row as illustrated in figure (5-11) and (5-12).But, the location of the whiteboard is very far for students who are sitting on the left side. Moreover, there is a window beside the whiteboard causing glares for the students attending the lab as you can see in figure (5-11).



Figure 5.11: The Placement of Presentation Screen and Whiteboard.

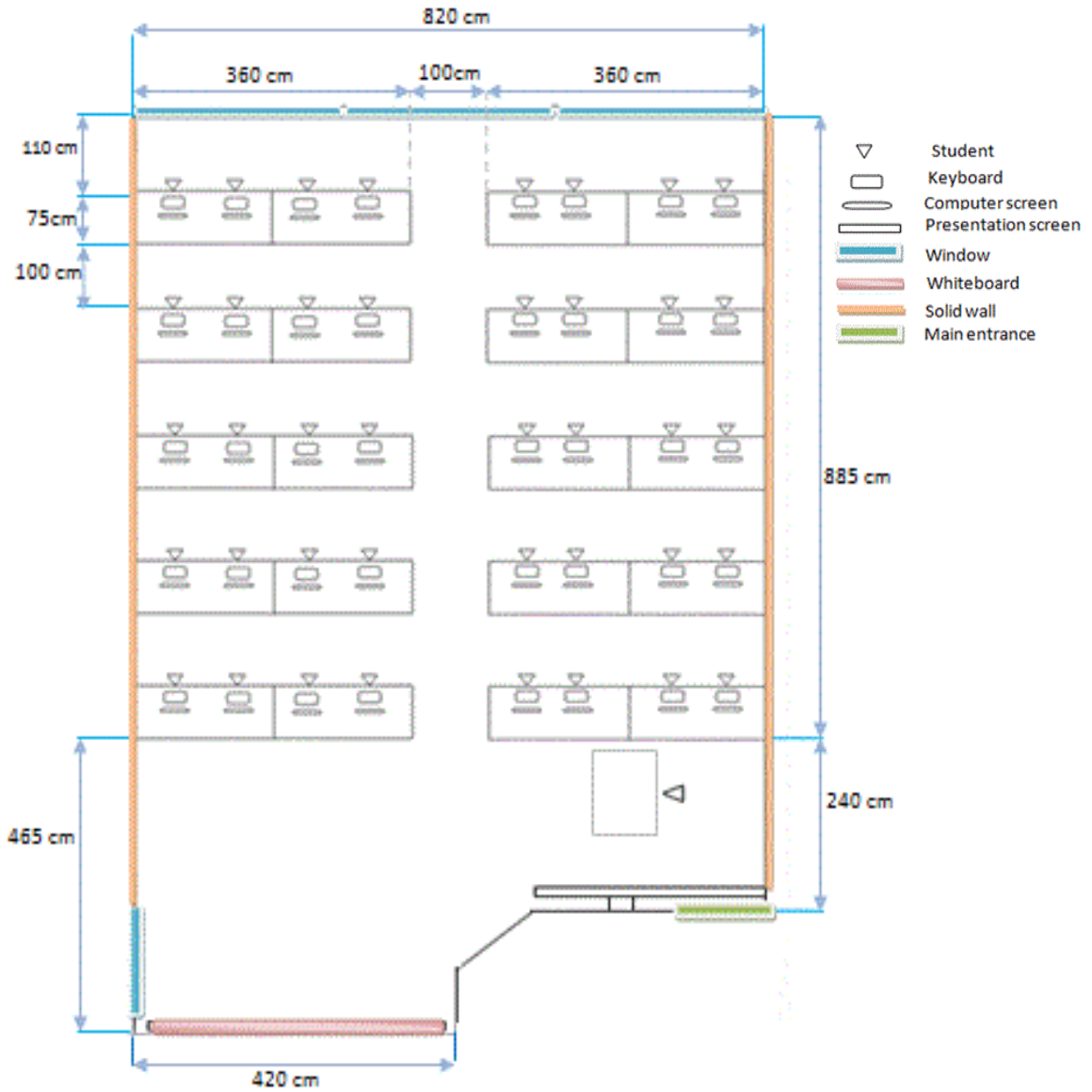

Figure 5.12: Top View for Current Layout of Computer Laboratory Classroom

7. The instructor's table was very close to the entrance as well as to the first row on the left side of the lab. Additionally, it is orthogonal to workstations in the front of the lab room, as can be seen in figure (5-13).



Figure 5.13: The Position of Teacher's Table

8. The windows which are at the end of the lab are covered by curtains. But, sometimes because of air flows they cause glare on the students' screens which are in the last row, as can be seen in figure (5-10) and (5-14).



Figure 5.14: Glare on Computer's Screen

9. Students who are sitting at the end of the sides either the right or left side are difficult to be reached by the professor as well as their entry or exit can cause noise.

10. There is a single corridor which constrains the movement of the professor.

Therefore, he/she is not able to see all the student's computer screens.

5.8 Proposal for Computer Workstation and Layout Design

After evaluating the furniture of the lab and layout we become able to know the weak points that are affecting the performance of both teacher and students. Then, a proposed design is prepared to get rid of the weaknesses in the current lab design by applying the ergonomic principles in design. The new design would minimize the incompatibility in the current PC Lab design. Based on our ergonomical knowledge and analyzes we performed earlier in this research some important recommendations related to computer workstations such as screen angle, correct posture while sitting at computer, use document holder ect, are proposed to be implemented.

5.8.1 The Proposed Design of computer workstation

Table (5-19) and figure (5-15) show the proposal of ergonomic chair and desk design for computer lab.

Table 5.19-A: Dimensions of New Proposed Table

TABLE DIMENSIONS	DISTANCE/ ANGLE
Table height	640mm
Desk slop	0
Desk clearance	610 mm

Table 5.19-B: Dimensions of New Proposed Chair

SEAT DIMENSIONS	DISTANCE/ ANGLE
Adjustable seat height	390-470mm
Seat depth	402.5 mm
Seat width	467 mm
Maximum height to the bottom of the backrest	175 mm
Maximum height to top of backrest	467.2mm
Backrest tilt	90°-110°
Seat pan tilt	3° up 4° down

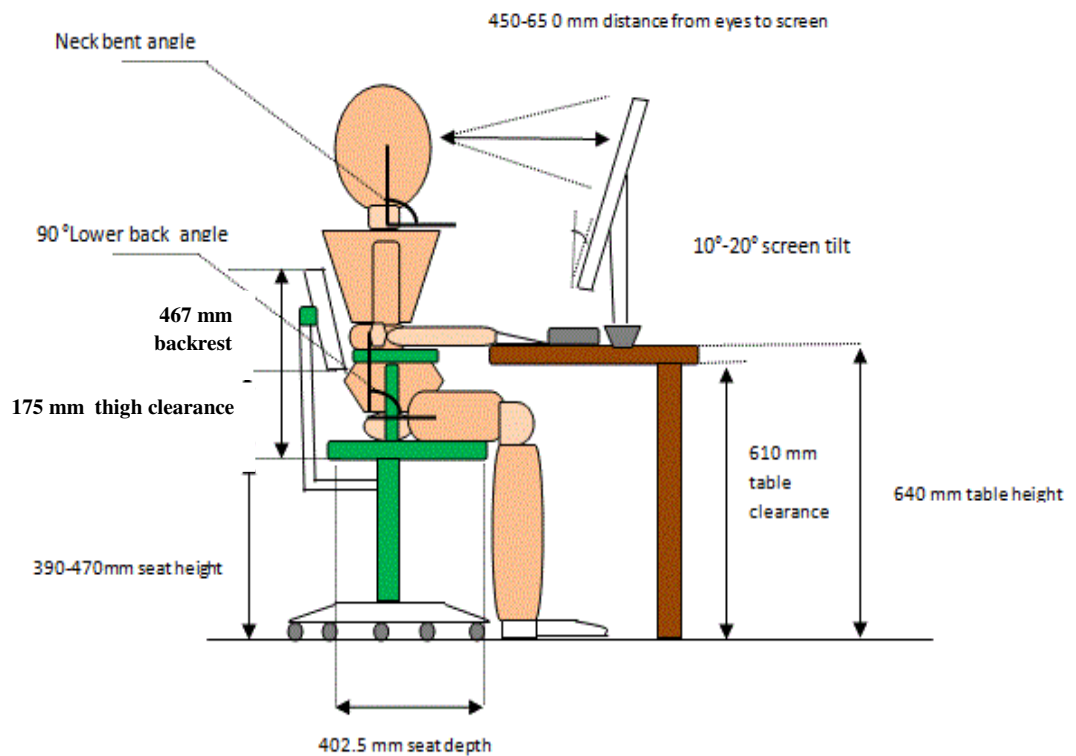

Figure 5.15: A Proposed Computer Workstation

Attention Should be Paid to the Following Points:

- The favorite viewing distance of the screen ranges from 45 to 65 cm.
- The height of the monitor surface should allow the position of the view center of the screen to be between 5 to 30 degrees below the horizontal plane through the eyes.
- Suitable monitor height can be accomplished by adjusting the screen surface or installing a screen stand that is height adjustable. If the monitor is very high, you can reduce the desk height when it is adjustable, or raises the chair and obtain a foot rest.
- Using the document holder could help to avoid the neck strain and reduce eye fatigue that are caused by looking up and down or moving the neck between the papers and computer screen.

5.8.2 The Proposed Layout of the Computer Lab.

Based on our study for the layout of computer lab, we identified problems related to the teacher and students such as, obstructing of movement through the lab, the placement of whiteboard and presentation screen.

Therefore, the following changes are proposed to the new sketch of lab layout:

- Create three corridors instead of one.
- Change the arrangement of workstations so that, they are perpendicular to the main entrance of the computer lab to reduce the glare of the windows as much as possible.
- Change the location of both the whiteboard and presentation screen where it is better to put them on the wall opposite to the all workstations and an in frontof the students.

The above proposed changes are implemented in the new proposed design of the PC Lab to facilitate and provide the appropriate environment for students to be able to concentrate on the lecture without fatigue or boredom, as well as for the professor to be able to interact with them. You can see the sketch of the proposed design as illustrated in figure (5-16).

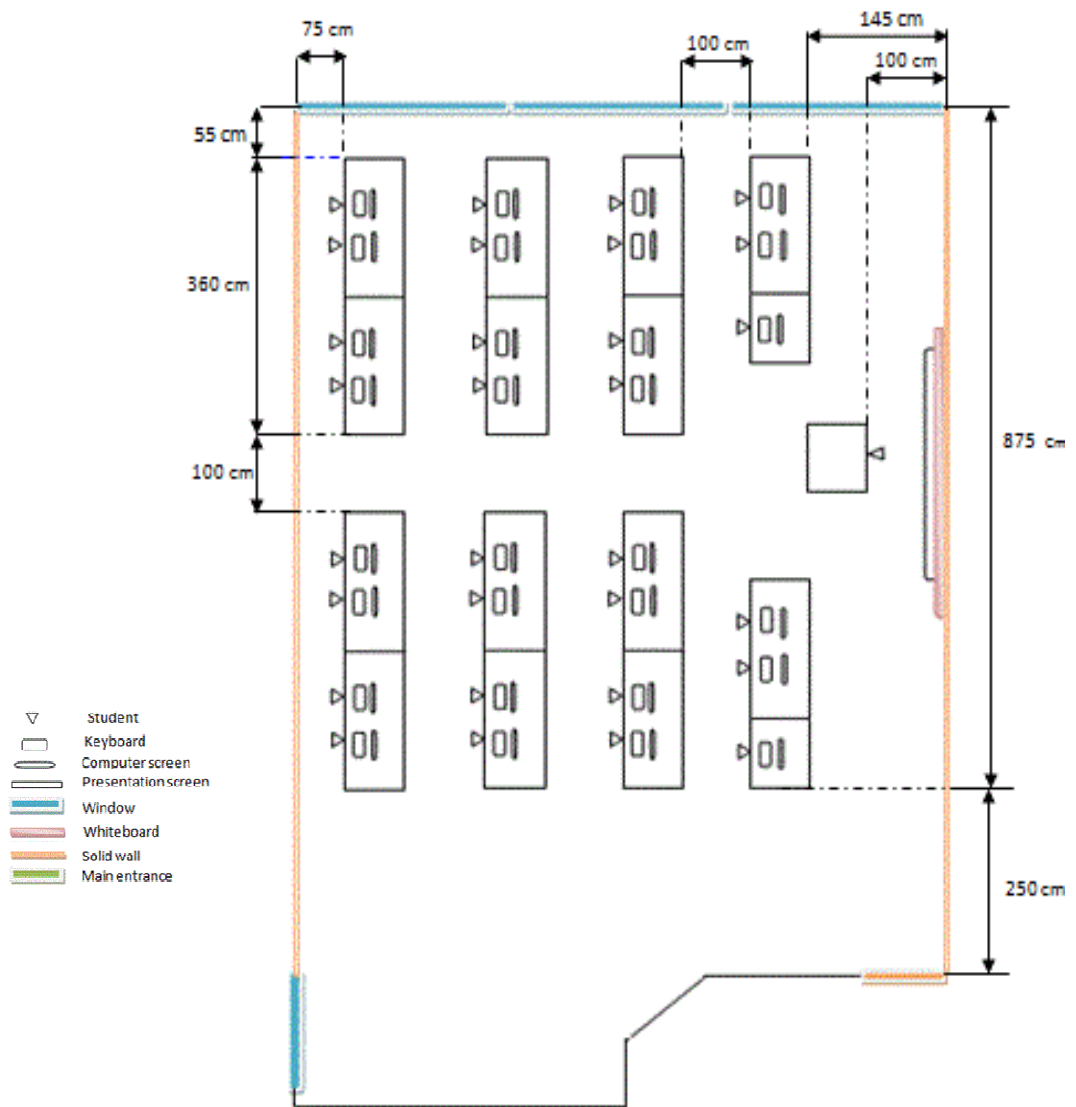

Figure 5.16: A proposed Computer Lab Layout.

Chapter 6

DISCUSSION AND CONCLUSION

Our Observations, in this Thesis Work and Recommendations Can be Summarized as Follow:

The number of existing workstations is large as compared to the average number of students enrolled in each lab group which is 25.

Hypotheses testing indicate there are statistically significant differences between body dimensions of female and male students. This result helped us to specify in the design which principles of anthropometry parts should be used (e.g. design for adjustable range, or design for extreme or design for average). In this way, we were able to improve the proportion of matching method and obtain the best matching rate for males and females students.

The current tables of computer workstations in the lab are very high so that, the students' posture is not good because the angle between the upper and lower arm was greater than 90 degrees. This can increase the tension in muscles and cause a decrease in the ability of students learning and concentration during the lecture and can cause serious health problems.

The mismatch ratio between female's sitting elbow height and table height was higher than male mismatch ratio. This appears clearly by referring to the hypotheses test which was done to examine the means of table height for both genders. It was found that a significant difference exists between male and females' table height. Therefore, we decided to design the table with height of 640 mm to reduce the mismatch from 87% and 96.3% to 13% and 11.1% for male and female students respectively. Noting that, this height was taken from the mean of female's table height.

The current chair doesn't have an armrest and also it isn't adjustable, thus, the incompatibility occurs between seat height and students' poplital height. The mismatch for male students were higher than females therefore, we have proposed an adjustable chair where the seat height ranges from 390 mm to 470mm. This reduced the mismatch ratio from 26% and 18% to 0% and 7% for male and female respectively.

The current arrangement of workstations is a conventional straight rows, also we found the aisles were' not enough for movement of the teacher throughout the lab in order to provide guidance for students. There was a single aisle dividing the lab into two sides. Students who sit at the end of each row on each side upon their late arrivals cause significant noise during a lesson session. Additionally, the teacher is not able to see all the screens available in the lab. Thus, we suggested creating new free spaces such as aisles to make possible the smooth movement of students and instructors around the sides of the lab. This would make the instructor capable to reach all students and enhance the cooperation between students and teachers.

The students who sit in the last rows of the lab were observed to suffer because of the distant location of the presentation screen and the whiteboard from them. It is very difficult for them to focus during the lecture and most of the time feels bored and sleepy. So, we proposed reducing the distance between the last row, and both the whiteboard and the presentation screen.

It was observed that, the placement of presentation screen is not suitable for teacher and students. It is placed above the main entrance of the lab. Looking at the screen continuously in this location may cause significant stresses in the neck region. This makes students not able to follow the explanation of teacher during a lesson. Therefore, a new proposed location for the presentation screen is suggested where all students can watch it carefully without any obstacles or any significant stress to the human body.

The table of teacher is put perpendicularly to the first row of workstations and very close to the entrance of the lab. This location causes dilemma near the door. Therefore, we recommend the distance from the entrance to any furniture should be at least 300 cm (It is 175 cm currently).

It is not possible to take advantage of the natural lighting in the current PC lab because, it may cause glares on the PC screens, especially who sit in the last rows. So, it is necessary to use curtains permanently in the lab with the Florentine Lighting. Therefore, to avoid this glare we proposed rearrangement of the computer workstations and to place them orthogonal rather than parallel to the windows. This would make, the glares coming from PC Lab windows not vertical to the computer screens.

Further Study that Can be Done.

- A study to provide the comfortable environmental conditions in the PC Lab for students, and to motivate them to work efficiently. For instance, humidity, temperature, noise and audio effects should be set properly, to increase motivation of the student to focus and pay more attention to the lecture, according to Ergonomy Principles of Design.
- Assessing the Safety factors of electricity installation in the computer lab.
- Extending this study to consider other computer labs in Industrial Engineering Department.

REFERENCES

Angsumalin, H. L. (2010). The Application of Anthropometric Design for University Desk and Seat Heights. *The 11th Asia Pacific Industrial Engineering and Management Systems Conference*. Bangkok, Thailand: Chulalongkorn University.

Ashraf, M. (2007). Office Ergonomics: Deficiencies in Computer. *International Journal of Occupational Safety and Ergonomics (JOSE)* , 13,2,215-223.

Callahan, J. L. (2004). *Effects of different seating arrangements in higher education computer lab classroom on student learning , teaching style, and classroom appraisal*. University of FLORIDA.

Castellucci, P. A. (2010). Mismatch between classroom furniture and anthropometric measures in Chilean schools. *Applied Ergonomics*, 41, 563-568.

Cornell, P. (2003). The impact of change in Teaching and Learning on Furniture and the learning Environment. *new Direction in teaching and Learning* , 1-9.

Dowler, E. (1998). *Effects of Neutral Posture on Muscle Tension, Pain, and Performance for Computer Users*. Australia.

EOHSS. (2008). *Computer Workstation Ergonomics* .

http://www.umdnj.edu/eohssweb/publications/computer_ergo_guide.pdf: Department of EOHSS.

Gouvali, B. (2006). Match between school furniture dimensions and children's anthropometry. *Ergonomics, Applied* , 37, 765-573.

Healthcare Ergonomics. (2003-2012). Retrieved march 12, 2013, from the human solution : <http://www.thehumansolution.com/index.html>

(2009). *How to Make Your Computer Workstation fit you*. WorkSafeBC.com: Work Safe BC publications.

Mike May, S. *Designing a Computer Classroom*. Saint Louis University 221 N Grand: Department of Mathematics and Mathematical Computer Science.

Min Yong, J. K. (2000). Ergonomic design and evaluation of a new VDT workstation chair with Keyboard- mouse support. *International Journal of Industrial Ergonomics* , 537-548.

Nicolas, S. M. (2007). Supporting the design of office layout meeting ergonomics requirements. *Applied Ergonomics* , 38, 781-790.

Parcells, S. M. (1999). Mismatch of classroom furniture and student body dimensions. *empirical findings and health Implications. J. Adolesc. Health* , 265–273.

Scott-Webber, L. M. (2000). Higher Educational classrooms fail to meet needs of faculty and students. *Interior design* , 26,1,16-34.

Sommer, R. (1967). Classroom Ecology. *Applied Behavioral science* , 3,489-503.

Sweere, H. C. (2002). *Ergonomics factors involved in optimum computer workstation design.*

http://www.ergotron.com/portals/0/literature/whitepapers/english/ergonomic_factors.pdf

Tamer, S. L. (2010). Evaluating instructional computer laboratories in terms of physical ergonomic criteria. *Uluslararası İnsan Bilimleri Dergisi* , 7, 721-745.

Timoteo-Afinidad, C. B. (2010). Workstation and workspace Ergonomics in Philippine Libraries. *Journal of Philippine Librarianship* , 30,21-44.

APPENDICES

**Appendix A: Anthropometric Measures of Eastern Mediterranean
University Students**

Table A.1: Anthropometric Measures of Fifty Students in mm.

NO.	STUDENT NUMBER	Sex	Age	Weight (KG)	Height	Shoulder height(SDH)	Shoulder elbow height	Buttock popliteal height	Popliteal height	Knee height	Forearm length	Hip width	Elbow sitting height(EH)	Sitting height	Sitting eye height	$ES = 0.852 EH + 0.148 SDH$
1	81720	f	25	71	1820	579	333	485	461	549	472	462	246	874	772	295.284
2	47936	f	25	47	1650	545	321	446	422	500	421	349	224	782	684	271.508
3	47145	m	25	115	1760	564	337	479	437	562	461	447	227	844	768	276.876
4	51324	m	26	73.5	1700	544	328	453	408	508	455	366	216	839	759	264.544
5	81773	m	22	71	1710	523	330	460	413	526	465	355	193	837	752	241.84
6	71223	f	22	57.5	1740	547	313	467	439	523	450	352	234	834	747	280.324
7	72392	f	24	75	1760	572	313	463	432	524	457	452	259	865	769	305.324
8	89529	m	22	59	1705	541	316	456	443	504	426	337	225	806	730	271.768
9	118610	f	18	56	1610	490	292	435	417	502	434	357	198	758	664	241.216
10	89712	f	19	71	1740	545	334	481	415	562	471	406	211	844	769	260.432
11	47682	f	19	58	1590	505	309	446	407	508	426	392	196	737	646	241.732
12	115671	f	32	59	1650	518	304	451	427	503	445	425	214	772	678	258.992
13	115351	f	28	65	1480	472	258	425	385	448	385	365	214	670	585	252.184
14	116264	f	35	64	1670	509	317	457	420	502	433	456	192	793	708	238.916
15	118429	f	20	54	1700	513	311	452	433	512	447	380	202	815	716	248.028
16	118386	f	27	55	1630	506	300	447	423	510	460	355	206	760	668	250.4

Table A.1 Continued

NO.	STUDENT NUMBER.	Sex	Age	Weight (KG)	Height	Shoulder height(SDH)	Shoulder elbow height	Buttock popliteal height	Popliteal height	Knee height	Forearm length	Hip width	Elbow sitting height(EH)	Sitting height	Sitting eye height	$ES = 0.852 EH + 0.148 SDH$
17	118631	f	23	52.5	1700	521	320	477	443	508	459	325	201	780	695	248.36
18	115532	f	29	62.5	1550	504	277	429	389	471	453	356	227	732	647	267.996
19	115670	f	28	54.5	1620	508	295	442	412	480	468	335	213	766	681	256.66
20	115779	f	28	54.5	1510	478	293	427	407	469	411	365	185	676	591	228.364
21	48325	f	18	54	1680	520	317	447	432	511	436	338	203	801	705	249.916
22	59452	m	24	75	1710	528	339	463	420	518	467	390	189	827	738	239.172
23	115722	m	23	86	1740	563	344	468	432	547	475	420	219	840	762	269.912
24	115169	m	24	64	1700	545	320	452	438	513	447	382	225	810	720	272.36
25	81724	f	27	64	1620	517	319	443	419	494	451	412	198	758	673	245.212
26	51323	f	24	65.5	1620	521	285	449	420	486	436	423	236	751	666	278.18
27	72379	f	23	70	1710	542	316	488	429	524	450	437	226	793	708	272.768
28	51338	m	25	90	1810	564	327	511	461	528	493	354	237	838	755	285.396
29	109518	m	22	100	1810	570	354	518	455	564	502	388	216	837	758	268.392
30	115609	m	25	63	1730	540	329	484	433	526	467	368	211	813	720	259.692
31	81793	m	22	73.5	1750	545	326	451	441	510	459	372	219	858	769	267.248
32	71217	m	24	95	1780	552	338	453	452	535	475	397	214	875	785	264.024

Table A.1 Continued

NO.	STUDENT NUMBER.	Sex	Age	Weight (KG)	Height	Shoulder height(SDH)	Shoulder elbow height	Buttock popliteal height	Popliteal height	Knee height	Forearm length	Hip width	Elbow sitting height(EH)	Sitting height	Sitting eye height	$ES = 0.852 EH + 0.148 SDH$
33	72381	m	23	84.5	1775	544	336	448	431	549	487	363	208	896	804	257.728
34	81762	m	22	76.5	1825	584	309	470	462	535	498	373	275	893	798	320.732
35	57268	m	23	63	1710	538	315	449	435	512	450	314	223	826	737	269.62
36	81766	m	22	85	1760	543	309	456	435	544	451	358	234	869	765	279.732
37	72396	f	25	98	1680	527	286	461	426	510	431	467	241	793	708	283.328
38	71242	m	25	85	1770	558	333	466	448	506	467	374	225	856	768	274.284
39	89603	m	32	82	1680	530	317	439	408	503	455	367	213	833	751	259.916
40	48232	m	28	72	1725	525	308	458	430	527	478	363	217	837	755	262.584
41	112740	f	24	60.5	1600	510	261	427	395	462	426	458	249	778	693	287.628
42	105008	f	34	65	1620	515	280	431	389	460	421	400	235	800	715	276.44
43	47974	f	28	56	1790	547	347	453	451	524	462	443	200	886	794	251.356
44	105153	m	27	81	1810	573	343	502	463	547	488	390	230	845	768	280.764
45	116067	m	28	77	1850	573	371	497	461	535	493	376	202	892	792	256.908
46	81783	f	22	59	1680	528	307	451	433	510	425	385	221	796	698	266.436
47	71273	f	24	58	1680	530	302	454	434	491	431	381	228	792	707	272.696
48	72390	f	24	58	1630	510	293	445	439	498	435	376	217	746	661	260.364

Table A.1 Continued

NO.	STUDENT NUMBER.	Sex	Age	Weight (KG)	Height	Shoulder height(SDH)	Shoulder elbow height	Buttock popliteal height	Popliteal height	Knee height	Forearm length	Hip width	Elbow sitting height (EH)	Sitting height	Sitting eye height	ES= $0.852 \text{ EH} + 0.148 \text{ SDH}$
49	115081	m	27	67	1850	576	353	502	465	554	501	354	223	883	788	275.244
50	105493	m	27	69	1800	562	345	496	460	536	495	369	217	844	745	268.06

Table A.2: Anthropometric Measures of Male Students in mm.

NO.	STUDENT NUMBER.	Sex	Age	Weight (KG)	Height	Shoulder height(SDH)	Shoulder elbow height	Buttock popliteal height	Popliteal height	Knee height	Forearm length	Hip width	Elbow sitting height (EH)	Sitting height	Sitting eye height	ES= $0.852 \text{ EH} + 0.148 \text{ SDH}$
1	47145	m	25	115	1760	564	337	479	437	562	461	447	227	276.876	844	768
2	51324	m	26	73.5	1700	544	328	453	408	508	455	366	216	264.544	839	759
3	81773	m	22	71	1710	523	330	460	413	526	465	355	193	241.84	837	752
4	89529	m	22	59	1705	541	316	456	443	504	426	337	225	271.768	806	730
5	59452	m	24	75	1710	528	339	463	420	518	467	390	189	239.172	827	738
6	115722	m	23	86	1740	563	344	468	432	547	475	420	219	269.912	840	762
7	115169	m	24	64	1700	545	320	452	438	513	447	382	225	272.36	810	720
8	51338	m	25	90	1810	564	327	511	461	528	493	354	237	285.396	838	755
9	109518	m	22	100	1810	570	354	518	455	564	502	388	216	268.392	837	758

Table A.2 Continued

NO.	STUDENT NUMBER.	Sex	Age	Weight (KG)	Height	Shoulder height(SDH)	Shoulder elbow height	Buttock popliteal height	Popliteal height	Knee height	Forearm length	Hip width	Elbow sitng height(EH)	Sitting height	Sitng eye height	ES== 0.852 EH + 0.148 SDH
10	115609	m	25	63	1730	540	329	484	433	526	467	368	211	259.692	813	720
11	81793	m	22	73.5	1750	545	326	451	441	510	459	372	219	267.248	858	769
12	71217	m	24	95	1780	552	338	453	452	535	475	397	214	264.024	875	785
13	72381	m	23	84.5	1775	544	336	448	431	549	487	363	208	257.728	896	804
14	81762	m	22	76.5	1825	584	309	470	462	535	498	373	275	320.732	893	798
15	57268	m	23	63	1710	538	315	449	435	512	450	314	223	269.62	826	737
16	81766	m	22	85	1760	543	309	456	435	544	451	358	234	279.732	869	765
17	71242	m	25	85	1770	558	333	466	448	506	467	374	225	274.284	856	768
18	89603	m	32	82	1680	530	317	439	408	503	455	367	213	259.916	833	751
19	48232	m	28	72	1725	525	308	458	430	527	478	363	217	262.584	837	755
20	105153	m	27	81	1810	573	343	502	463	547	488	390	230	280.764	845	768
21	116067	m	28	77	1850	573	371	497	461	535	493	376	202	256.908	892	792
22	115081	m	27	67	1850	576	353	502	465	554	501	354	223	275.244	883	788
23	105493	m	27	69	1800	562	345	496	460	536	495	369	217	268.06	844	745

Table A.3: Anthropometric Measures of Female Students in mm.

NO.	STUDENT NUMBER.	Sex	Age	Weight (KG)	Height	Shoulder height(SDH)	Shoulder elbow height	Buttock popliteal height	Popliteal height	Knee height	Forearm length	Hip width	Elbow sitting height(EH)	Sitting height	Sitting eye height	ES== 0.852 EH + 0.148 SDH
1	81720	f	25	71	1820	579	333	485	461	549	472	462	246	295.3	874	772
2	47936	f	25	47	1650	545	321	446	422	500	421	349	224	271.5	782	684
3	71223	f	22	57.5	1740	547	313	467	439	523	450	352	234	280.3	834	747
4	72392	f	24	75	1760	572	313	463	432	524	457	452	259	305.3	865	769
5	118610	f	18	56	1610	490	292	435	417	502	434	357	198	241.2	758	664
6	89712	f	19	71	1740	545	334	481	415	562	471	406	211	260.4	844	769
7	47682	f	19	58	1590	505	309	446	407	508	426	392	196	241.7	737	646
8	115671	f	32	59	1650	518	304	451	427	503	445	425	214	259	772	678
9	115351	f	28	65	1480	472	258	425	385	448	385	365	214	252.2	670	585
10	116264	f	35	64	1670	509	317	457	420	502	433	456	192	238.9	793	708
11	118429	f	20	54	1700	513	311	452	433	512	447	380	202	248	815	716
12	118386	f	27	55	1630	506	300	447	423	510	460	355	206	250.4	760	668
13	118631	f	23	52.5	1700	521	320	477	443	508	459	325	201	248.4	780	695
14	115532	f	29	62.5	1550	504	277	429	389	471	453	356	227	268	732	647
15	115670	f	28	54.5	1620	508	295	442	412	480	468	335	213	256.7	766	681

Table A.3 Continued

NO.	STUDENT NUMBER.	Sex	Age	Weight (KG)	Height	Shoulder height(SDH)	Shoulder elbow height	Buttock popliteal height	Popliteal height	Knee height	Forearm length	Hip width	Elbow sitting height(EH)	Sitting height	Sitting eye height	$ES = 0.852 EH + 0.148 SDH$
16	115779	f	28	54.5	1510	478	293	427	407	469	411	365	185	228.4	676	591
17	48325	f	18	54	1680	520	317	447	432	511	436	338	203	249.9	801	705
18	81724	f	27	64	1620	517	319	443	419	494	451	412	198	245.2	758	673
19	51323	f	24	65.5	1620	521	285	449	420	486	436	423	236	278.2	751	666
20	72379	f	23	70	1710	542	316	488	429	524	450	437	226	272.8	793	708
21	72396	f	25	98	1680	527	286	461	426	510	431	467	241	283.3	793	708
22	112740	f	24	60.5	1600	510	261	427	395	462	426	458	249	287.6	778	693
23	105008	f	34	65	1620	515	280	431	389	460	421	400	235	276.4	800	715
24	47974	f	28	56	1790	547	347	453	451	524	462	443	200	251.4	886	794
25	81783	f	22	59	1680	528	307	451	433	510	425	385	221	266.4	796	698
26	71273	f	24	58	1680	530	302	454	434	491	431	381	228	272.7	792	707
27	72390	f	24	58	1630	510	293	445	439	498	435	376	217	260.4	746	661

Appendix B: Analysis of Anthropometric Measures

Percentile Definition

Percentile is the value of a variable under which a specific percent of observations fall.

The k^{th} percentile is that place in the data where $k\%$ of the data is below the cut point.

The 25th percentile is that the area under the curve when ($z = -1.65$) as shown in figure (B-1)

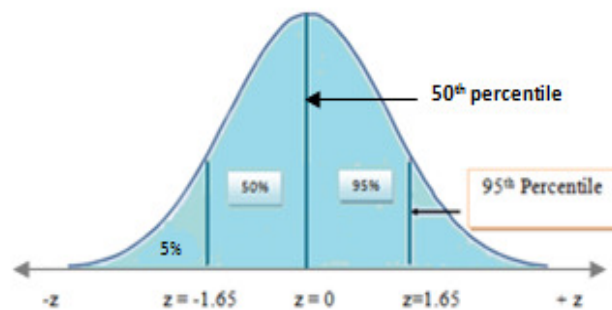

Figure B.1: The 5th , 50th and 95th percentile

There are many alternative approaches to defining percentiles for instance the median is the 50th percentile, the first quartile is the 25th percentile, and the third quartile is the 75th percentile. It could be of importance to compute other percentiles, such as the 5th or 95th.

Notice to the percentiles above the mean have a positive Z-value and the lower average have a negative percentile.

Table B.1: The Common Percentiles

$p_1 = \mu - 2,33 \sigma$	$p_{99} = \mu + 2,33 \sigma$
$p_{2.5} = \mu - 1.96 \sigma$	$p_{97.5} = \mu + 1.97 \sigma$
$p_5 = \mu - 1.65 \sigma$	$p_{95} = \mu + 1.65 \sigma$
$p_{10} = \mu - 1.82 \sigma$	$p_{90} = \mu + 1.82 \sigma$
$p_{20} = \mu - 0.84 \sigma$	$p_{80} = \mu + 0.84 \sigma$
$p_{25} = \mu - 0.67 \sigma$	$p_{75} = \mu + 0.67 \sigma$

Table B.2: Anthropometric Data for the Overall Subjects

Anthropometric measurement	Mean	Median	S.D (σ)	Max	Min	5th	95th
Weight kg.	69.43	65.25	14.214	115	47	45.976	92.8
Height mm	170.38	170.75	8.405	185	148	156.512	184.24
Shoulder height	535.28	539	26.23	584	472	492.00	578.56
Shoulder elbow height	316.6	317	23.37	371	258	278.03	335.16
Buttock popliteal length	460.2	453.5	22.28	518	425	423.44	496.96
Popliteal height	430.6	432	20.21	465	385	397.24	463.95
Knee height	514.6	511.5	26.78	564	448	470.42	558.78
Forearm length	455.02	455	25.39	502	385	413.12	496.92
Hip breadth	384.58	375	38.1	467	314	321.73	447.43
Elbow sitting height	218.7	217	17.9	275	185	189.128	248.212
Sitting height	813	820.5	52.32	896	670	726.67	899.33
Sitting eye height	728	733.5	51.31	804	585	643.33	812.67

Table B.3: Mismatch Ratios for Fifty Students from Male and Females

Mismatch between	Number of mismatches	Ratio	Percentage
Popliteal height and seat height	11	11/50	22%
Buttock popliteal length and seat depth	7	7/50	14%
Knee height and table clearance	0	0	0
Elbow height and table height	46	46/50	92%
Hip breadth and seat width	28	28/50	56%

Table B.4: Anthropometric Data for Male

Anthropometric measurement	Mean	Median	S.D (σ)	Max	Min	5th	95th
Weight kg.	78.565	76.5	13.237	115	59	56.725	100.41
Height mm	175.91	176	5.0893	185	168	167.52	184.31
Shoulder height	551.52	545	17.508	584	523	522.63	580.41
Shoulder elbow height	331.61	330	16.013	371	308	305.19	358.03
Buttock popliteal length	470.91	463	22.913	518	439	433.11	508.72
Popliteal height	440.48	438	17.699	465	408	411.27	469.68
Knee height	529.96	528	18.671	564	503	499.15	560.76
Forearm length	471.96	467	20.25	502	426	327.27	435.86
Hip breadth	372.9	369	26.5689	447	314	329.07	416.75
Elbow sitting height	219.9	219	16.689	275	189	192.38	247.45
Sitting height	847.7	840	261.59	896	806	804.57	890.9
Sitting eye height	760.3	759	23.012	804	720	722	798

Table B.5: Mismatch Ratios for Male Students

Mismatch between	Number of mismatches	Ratio	Percentage
Popliteal height and seat height	6	6/23	26%
Buttock popliteal length and seat depth	6	6/23	26%
Knee height and table clearance	0	0	0
Elbow height and table height	20	20/23	87%
Hip breadth and seat width	13	13/23	56.5%

Table B.6: Anthropometric Data for Female

Anthropometric measurement	Mean	Median	S.D (σ)	Max	Min	5th	95th
Weight kg.	61.65	59	9.79	98	47	45.5	77.8
Height mm	165.7	165	7.815	182	148	152.8	178.6
Shoulder height	521.44	518	24.598	579	472	480.85	562.03
Shoulder elbow height	303.8	307	21.06	347	258	289.07	338.56
Buttock popliteal length	451.19	449	17.415	488	425	422.34	479.81
Popliteal height	422.5	423	18.57	461	385	391.53	452.83
Knee height	501.5	503	25.88	562	448	458.8	544.2
Forearm length	440.6	436	19.97	472	385	407.6	473.5
Hip breadth	394.51	385	43.74	467	325	322.3	466.71
Elbow sitting height	217.63	214	19.12	259	185	186.08	249.17
Sitting height	738.4	782	51.01	886	670	699.2	867.59
Sitting eye height	694.4	695	49.3	794	585	612.9	775.8

Table B.7: Mismatch Ratios for Female Students

Mismatch between	Number of mismatches	Ratio	Percentage
Popliteal height and seat height	5	5/27	18%
Buttock popliteal length and seat depth	1	1/27	4%
Knee height and table clearance	0	0	0
Elbow height and table height	26	26/27	96.3%
Hip breadth and seat width	15	15/27	55.5%

Table B.8: Proportion of Match Students at Different Seat Depth (SD)

SD	SD/.99	SD/0.8	P1	P2	P=P2-P1
320	336.8421	400	0	0.0034	0.003446
330	347.3684	412.5	0	0.0161	0.016139
360	378.9474	450	0	0.3235	0.323412
370	389.4737	462.5	0	0.5411	0.54036
380	400	475	0	0.7467	0.743296
390	410.5263	487.5	0.01	0.8898	0.876882
400	421.0526	500	0.04	0.963	0.923526
410	431.5789	512.5	0.1	0.9905	0.891083
420	442.1053	525	0.21	0.9982	0.789831
430	452.6316	537.5	0.37	0.9997	0.632696
440	463.1579	550	0.55	1	0.447164
450	473.6842	562.5	0.73	1	0.272516
460	484.2105	575	0.86	1	0.14059
470	494.7368	587.5	0.94	1	0.060555
480	505.2632	600	0.98	1	0.021558
490	515.7895	612.5	0.99	1	0.006297
500	526.3158	625	1	1	0.001501

Table B.9: Proportion of Match Students at Different Height of Backrest

Backrest	BH/0.8	BH/0.6	P1	P2	P=P2-P1
250	312.5	416.67	1E-17	5E-08	4.76E-08
275	343.8	458.33	1.4E-13	0.0003	0.000269
300	375	500	5E-10	0.0563	0.056251
320	400	533.33	1.3E-07	0.4651	0.465109
330	412.5	550	1.4E-06	0.7461	0.746067
360	450	600	0.00057	0.9982	0.997626
365	456.3	608.33	0.00129	0.9995	0.998199
370	462.5	616.67	0.00276	0.9999	0.997112
380	475	633.33	0.01078	1	0.989218
390	487.5	650	0.03426	1	0.96574
400	500	666.67	0.08931	1	0.910691
410	512.5	683.33	0.19257	1	0.807432
420	525	700	0.34756	1	0.65244
430	537.5	716.67	0.53372	1	0.466275
440	550	733.33	0.71267	1	0.287334
450	562.5	750	0.85031	1	0.149695
460	575	766.67	0.93502	1	0.064975
470	587.5	783.33	0.97675	1	0.023249
480	600	800	0.9932	1	0.006805
490	612.5	816.67	0.99838	1	0.00162
500	625	833.33	0.99969	1	0.000313

Table B.10: Proportion of Match Students at Different Seat Width

S W	SW/1.3	SW/1.1	P1	P2	P=P2-P1
320	246.1538	290.9091	0.00013943	0.007	0.006823
330	253.8462	300	0.000299314	0.013	0.012892
360	276.9231	327.2727	0.002353848	0.066	0.06387
370	284.6154	336.3636	0.004339681	0.103	0.098443
380	292.3077	345.4545	0.007707462	0.152	0.144459
390	300	354.5455	0.013191395	0.215	0.202006
400	307.6923	363.6364	0.021765473	0.291	0.269447
410	315.3846	372.7273	0.034636998	0.378	0.343196
420	323.0769	381.8182	0.053190245	0.471	0.417909
430	330.7692	390.9091	0.078868013	0.566	0.487117
440	338.4615	400	0.112990614	0.657	0.544208
450	346.1538	409.0909	0.156529224	0.74	0.583521
460	353.8462	418.1818	0.209869423	0.811	0.601288
470	361.5385	427.2727	0.272614893	0.869	0.596207
480	369.2308	436.3636	0.343484148	0.913	0.569523
490	376.9231	445.4545	0.420340736	0.945	0.524657
500	384.6154	454.5455	0.500370607	0.967	0.466513
520	400	472.7273	0.657199006	0.99	0.332472
540	415.3846	490.9091	0.790665443	0.997	0.206712
600	461.5385	545.4545	0.978330983	1	0.021657

Table B.11: Proportion of Match Students at Different Table Clearance

DU	UD-20	$P(Z \leq \text{UD-20})$
400	380	2.50227E-07
450	430	0.000791357
500	480	0.098177021
550	530	0.717373292
570	550	0.906896277
580	560	0.954990263
590	570	0.980713252
600	580	0.992699374
620	600	0.99928604
640	620	0.999958535
680	660	0.999999972
700	680	1
710	690	1
720	700	1
740	720	1
780	760	1

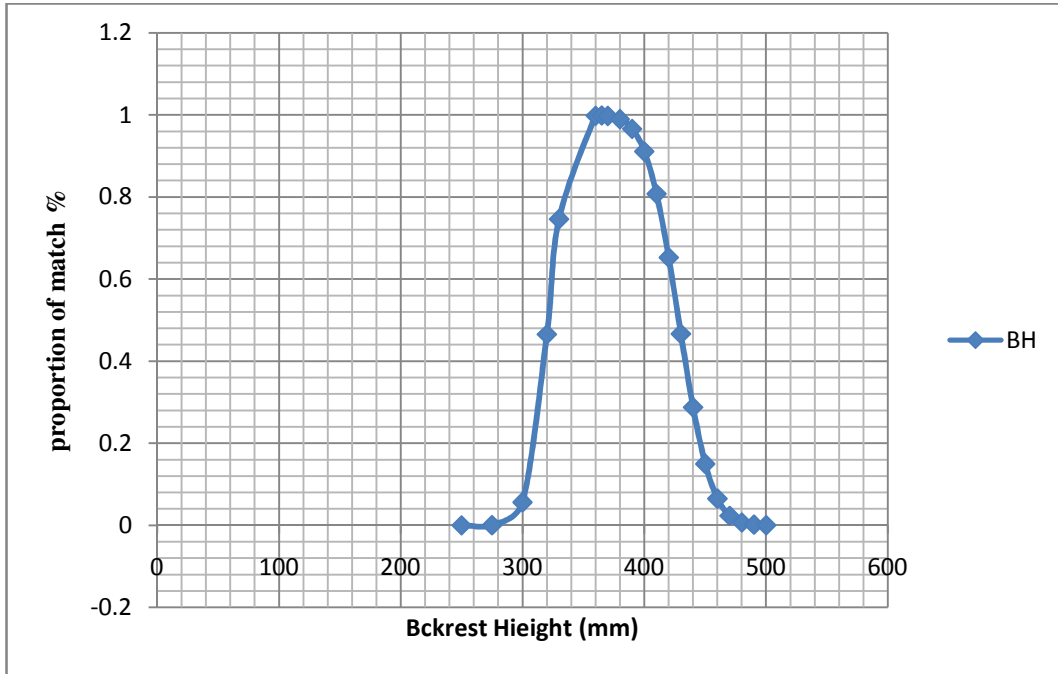

Figure B.2: Proportion of Match Population at Different Backrest Height.

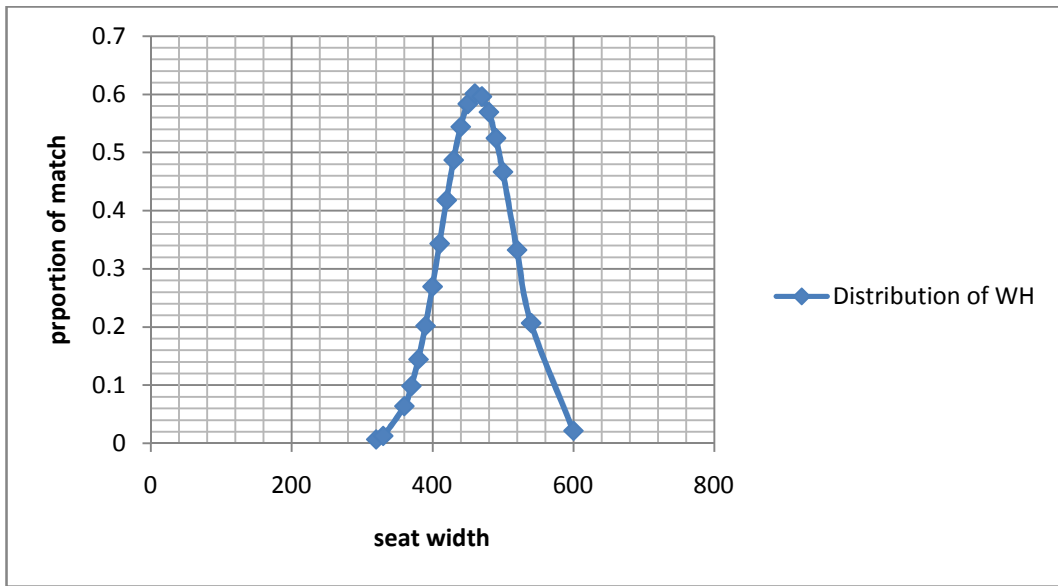

Figure B.3: Proportion of Match Population at Different Seat Width

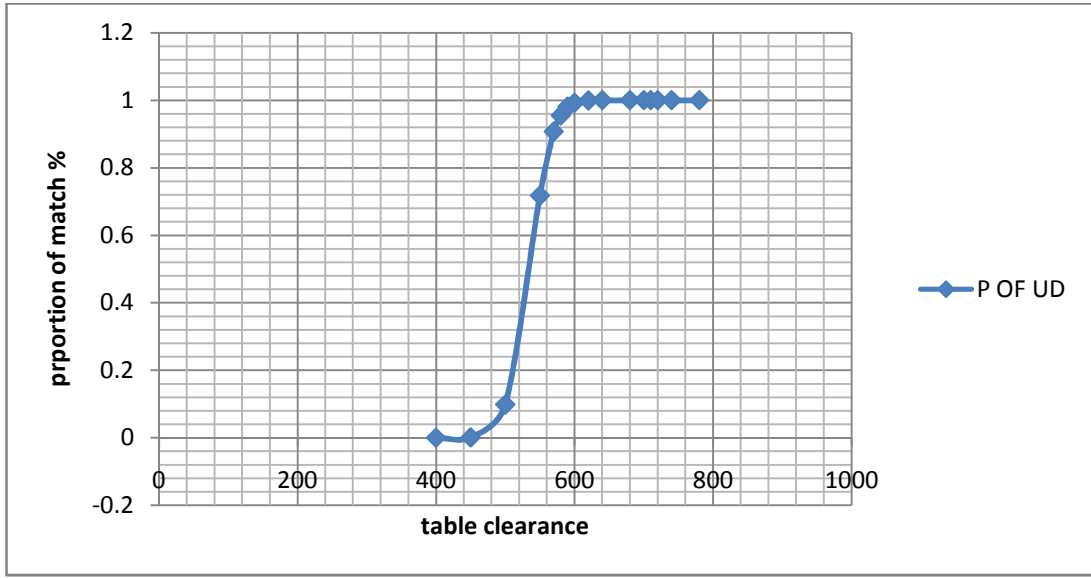

Figure B.4: Proportion of Match Population at Different Table Clearance.

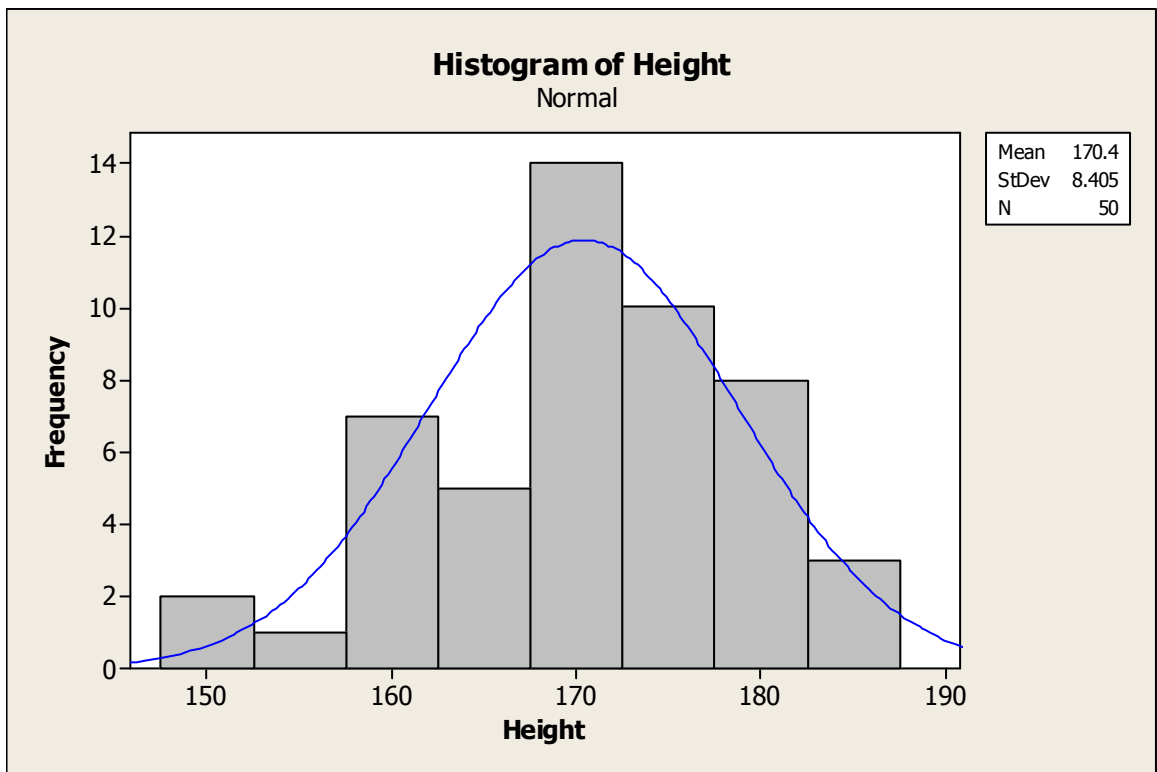

Figure B.5: Histogram of Students' Height

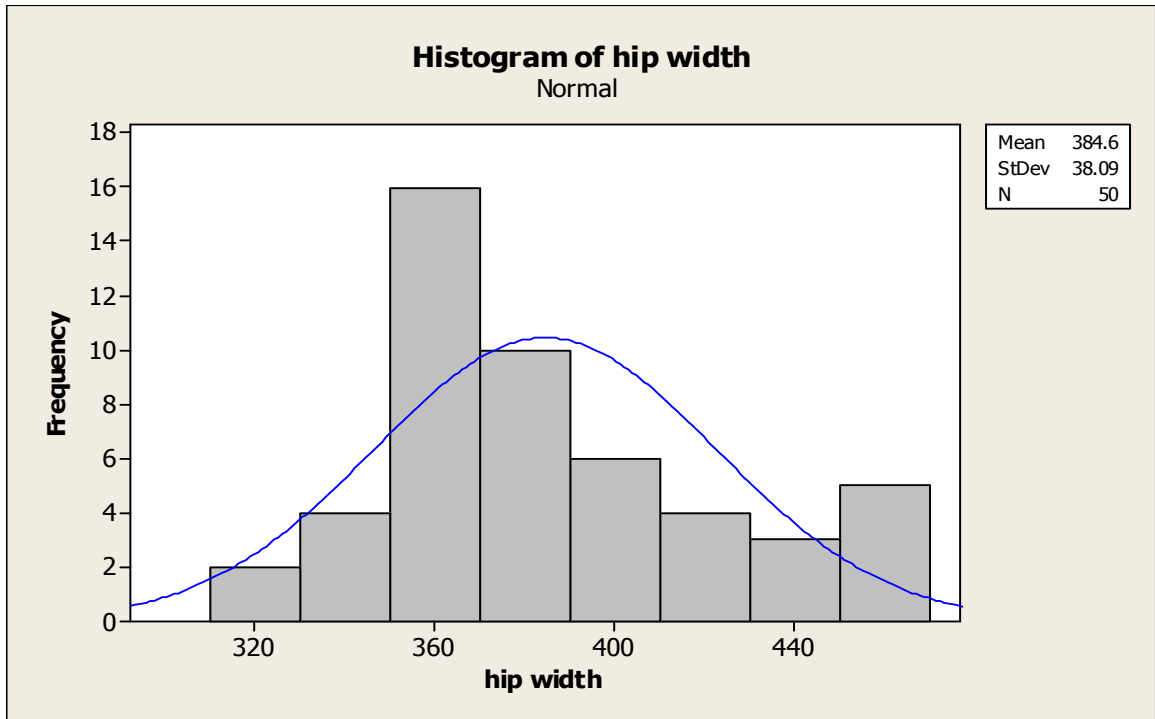

Figure B.6: Histogram of Hip Width

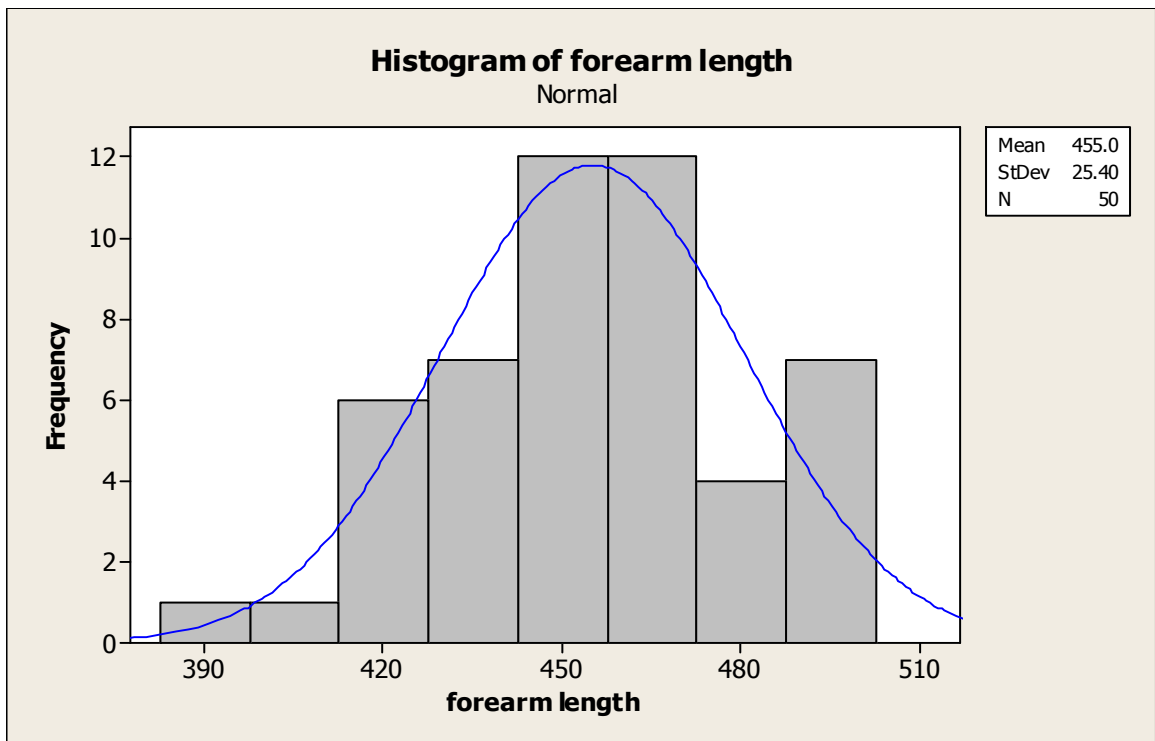

Figure B.7: Histogram of Forearm Length

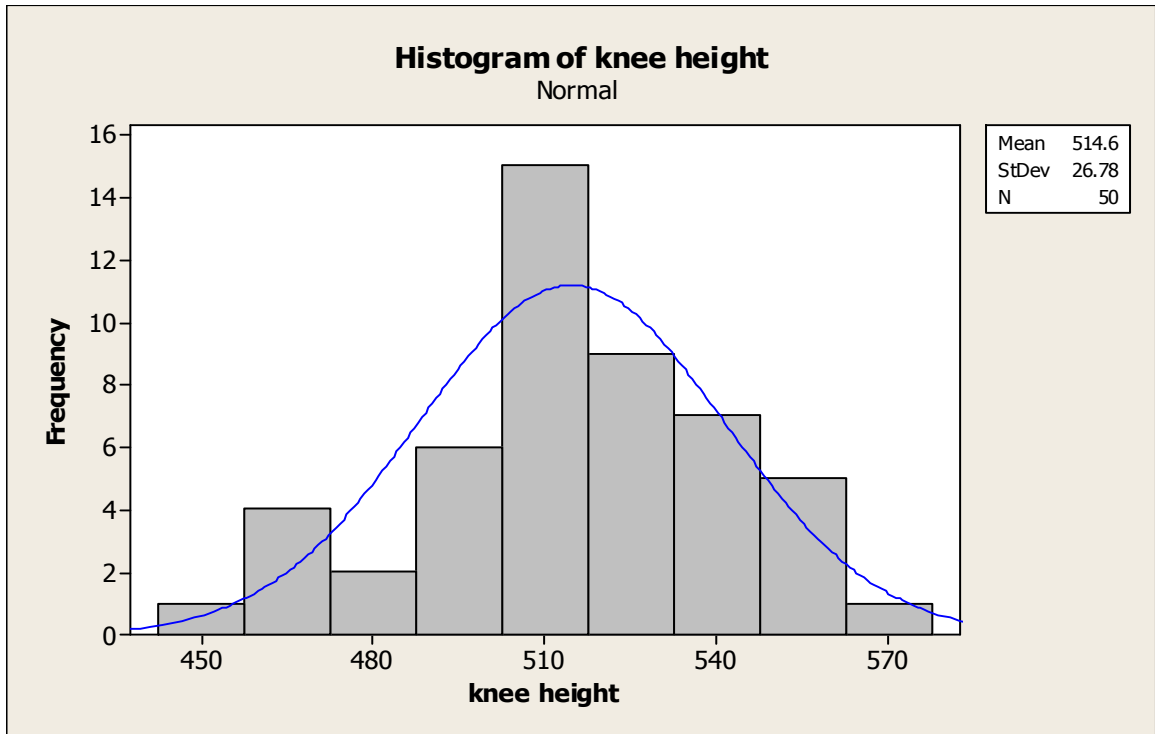

Figure B.8: Histogram of Knee Height

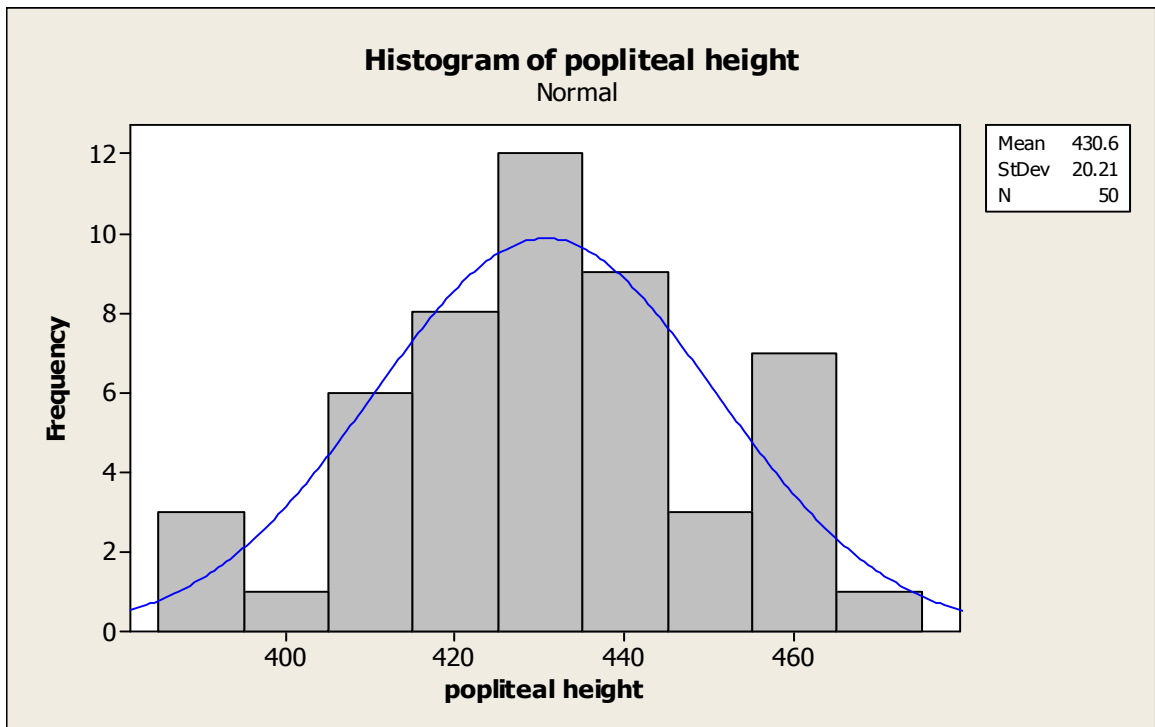

Figure B.9: Histogram of Popliteal Height

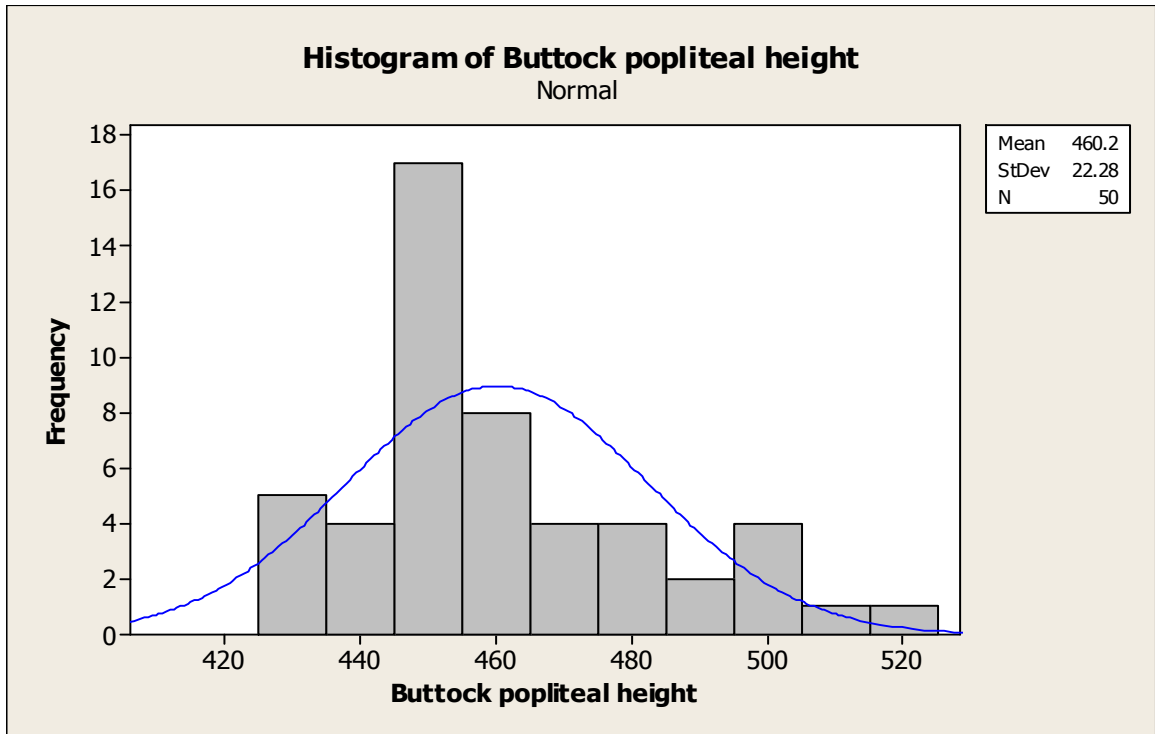

Figure B.10: Histogram of Elbow Height

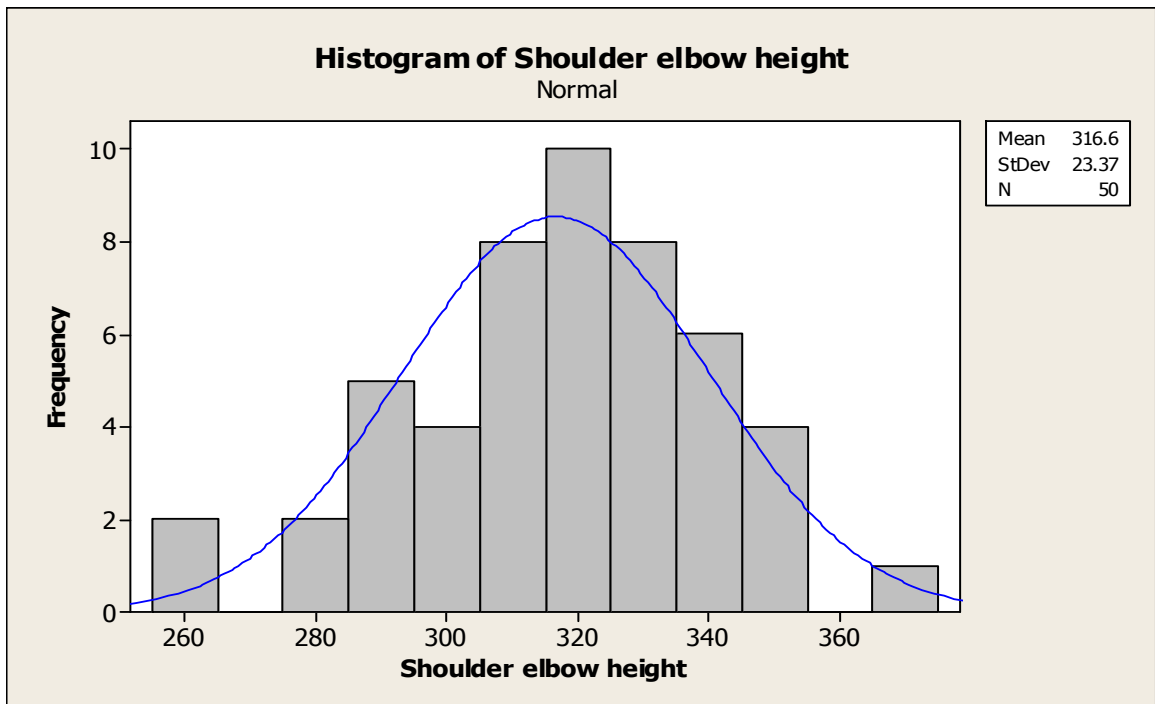

Figure B.11: Histogram of Shoulder Elbow Height

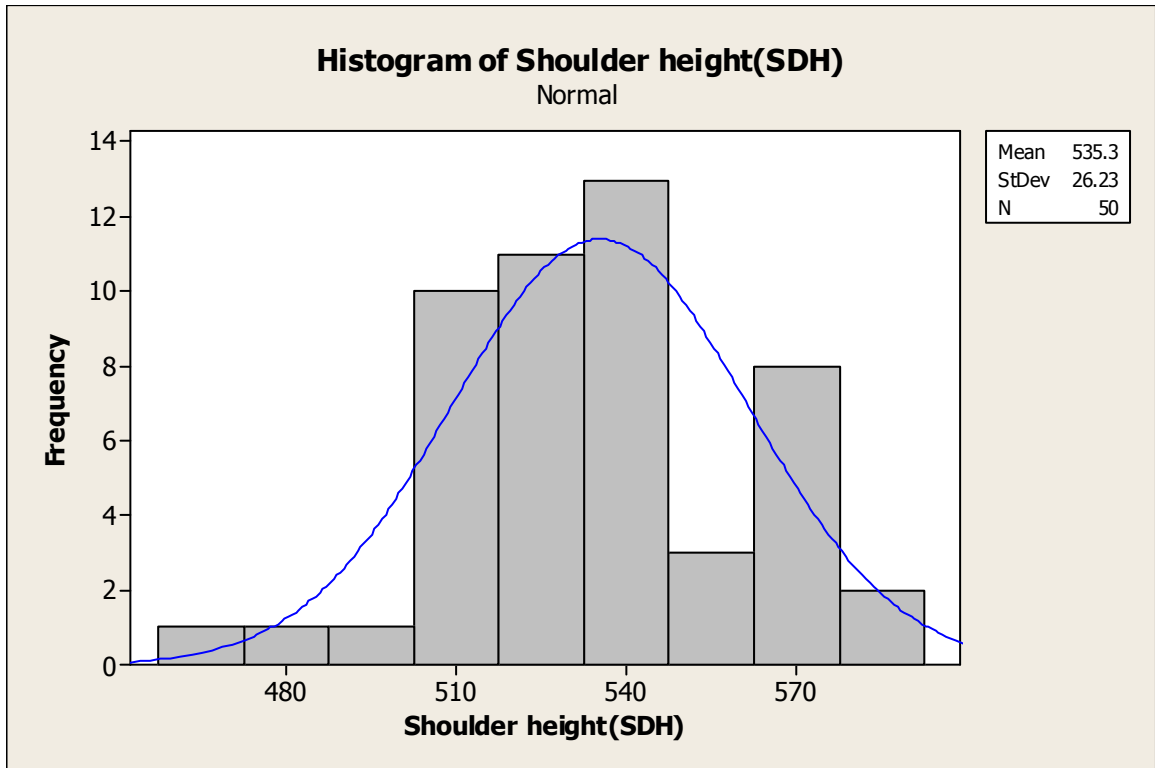

Figure B.12: Histogram of Shoulder Height

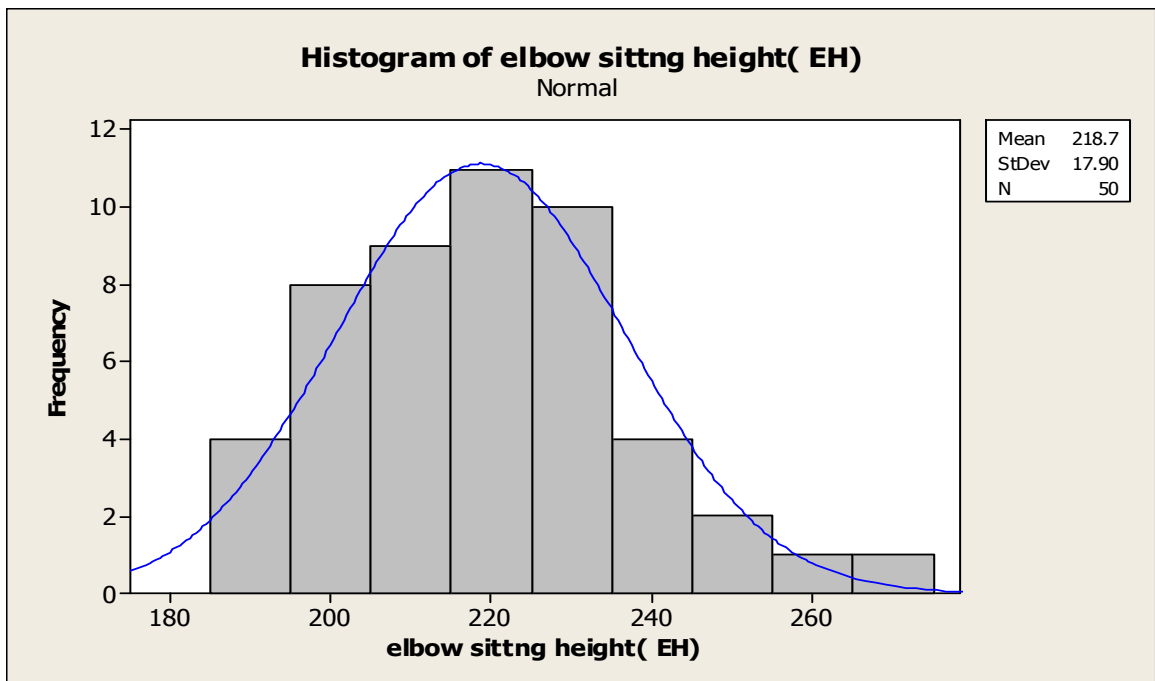

Figure B.13: Histogram of Elbow Sitting Height

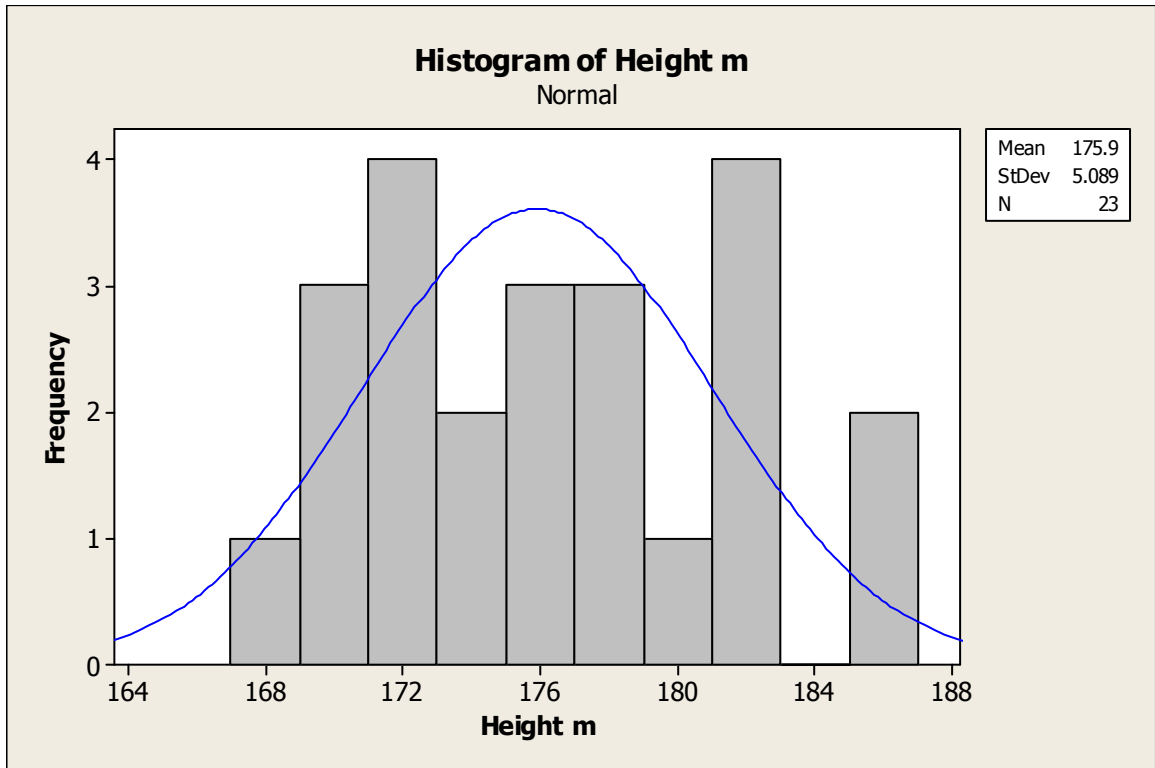

Figure B.14: Histogram of Male's Height

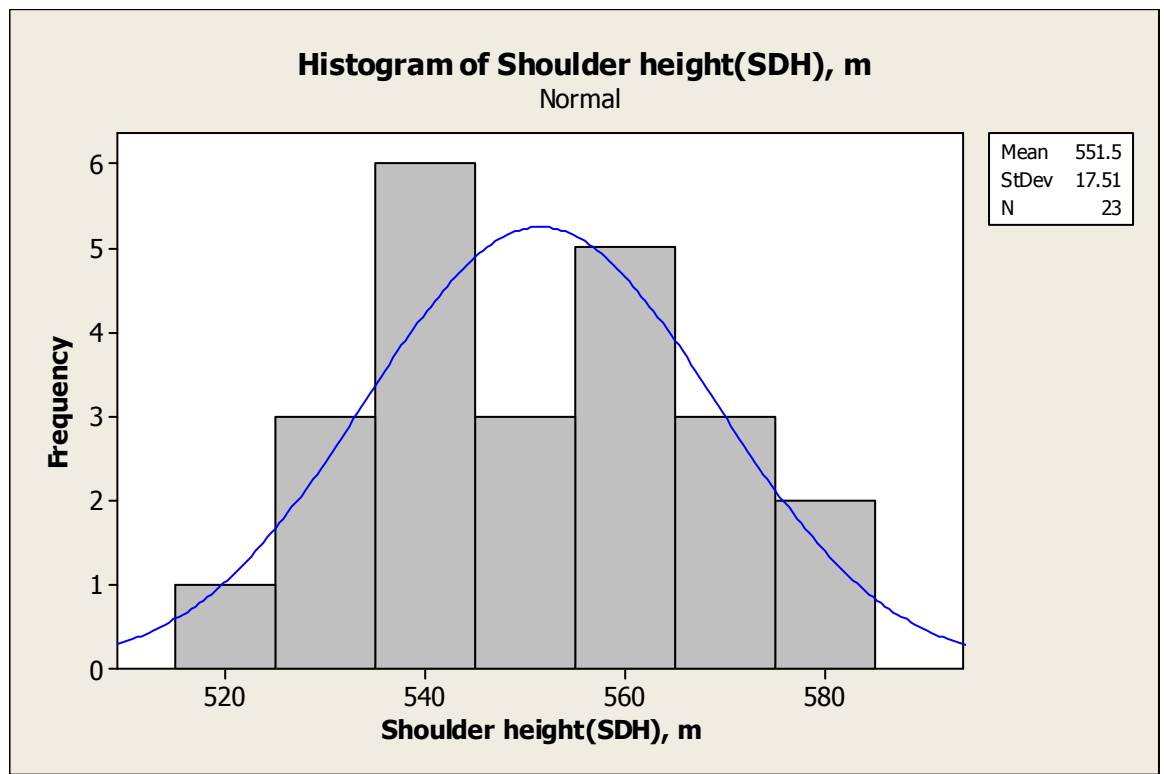

Figure B.15: Histogram of Male's Shoulder Height

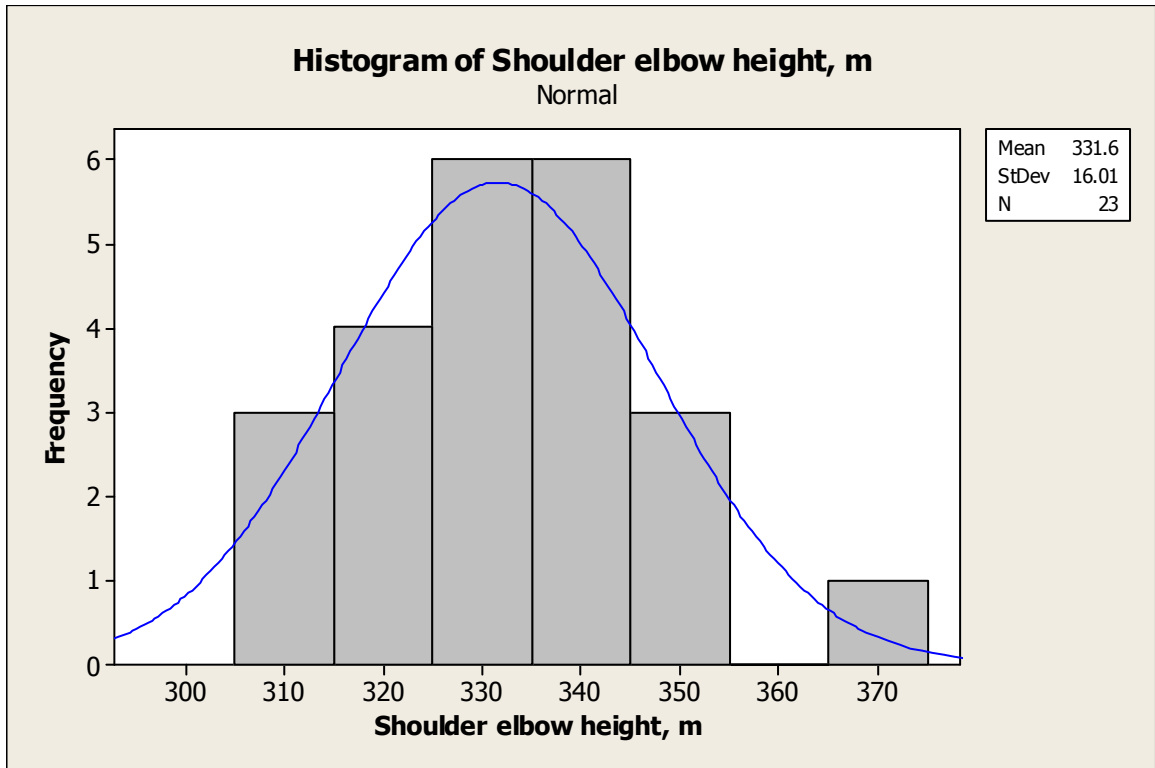

Figure B.16: Histogram of Male's Shoulder elbow Height

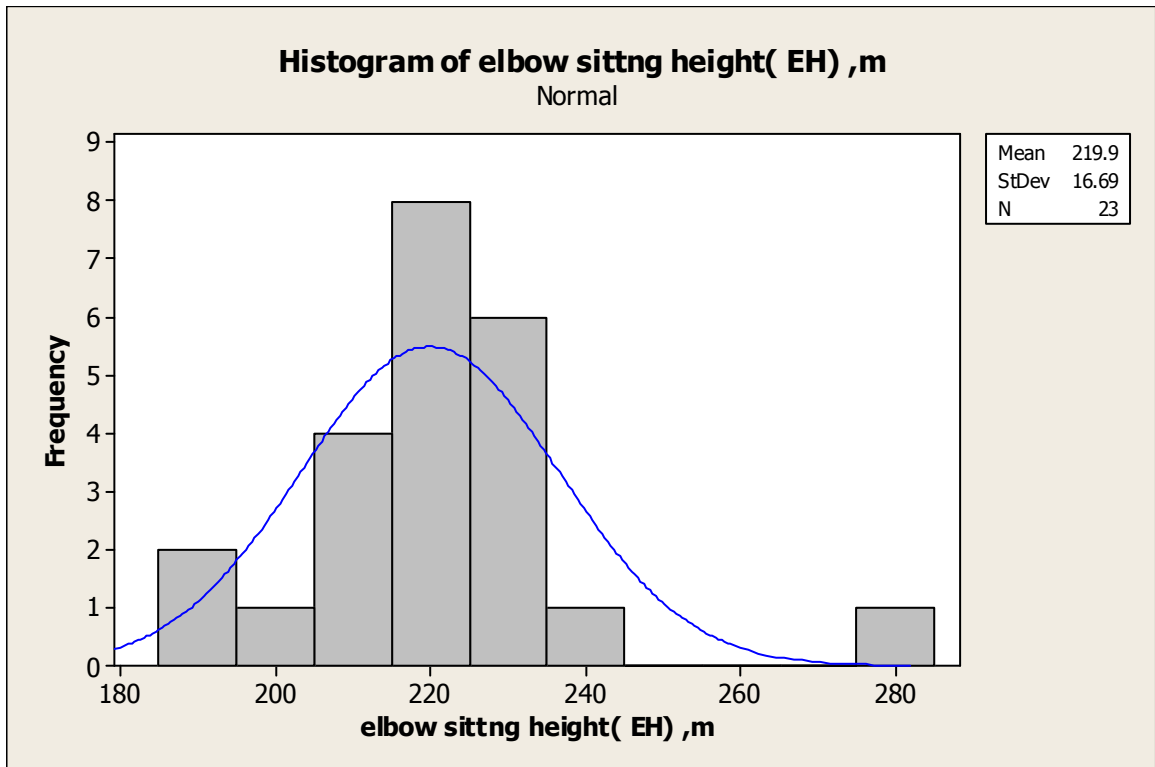

Figure B.17: Histogram of Male's Elbow Sitting Height

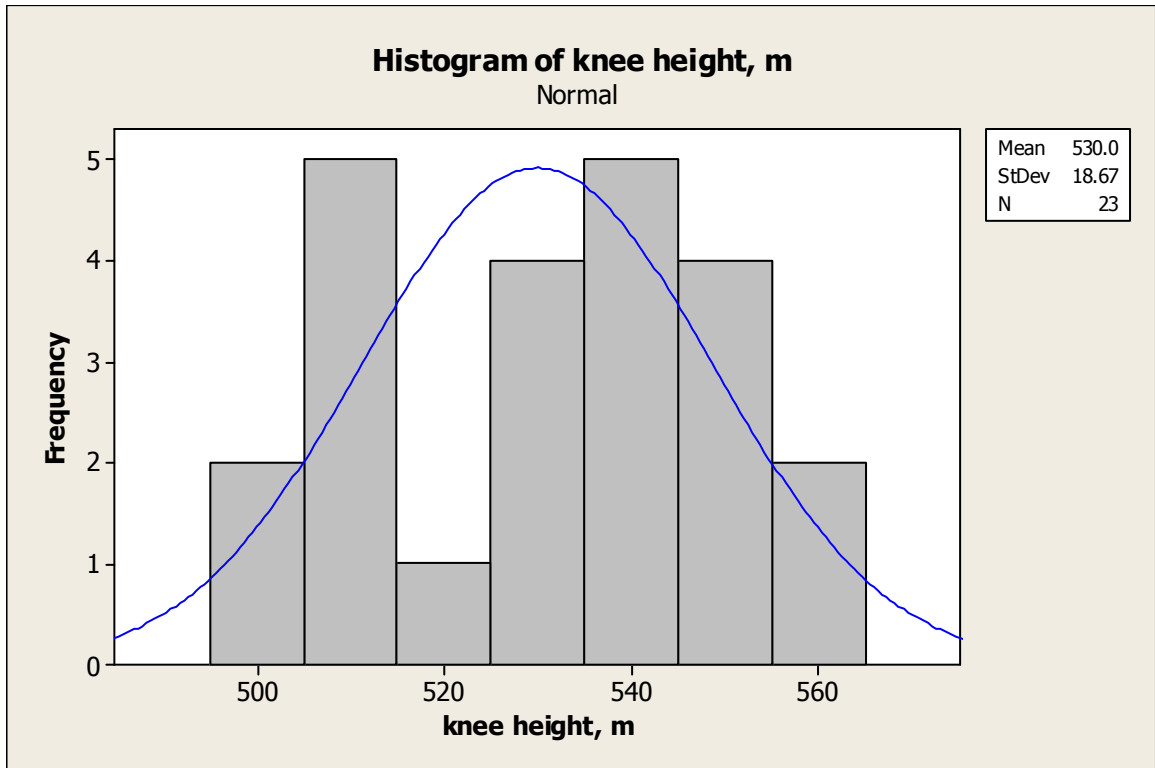

Figure B.18: Histogram of Male's Knee Height

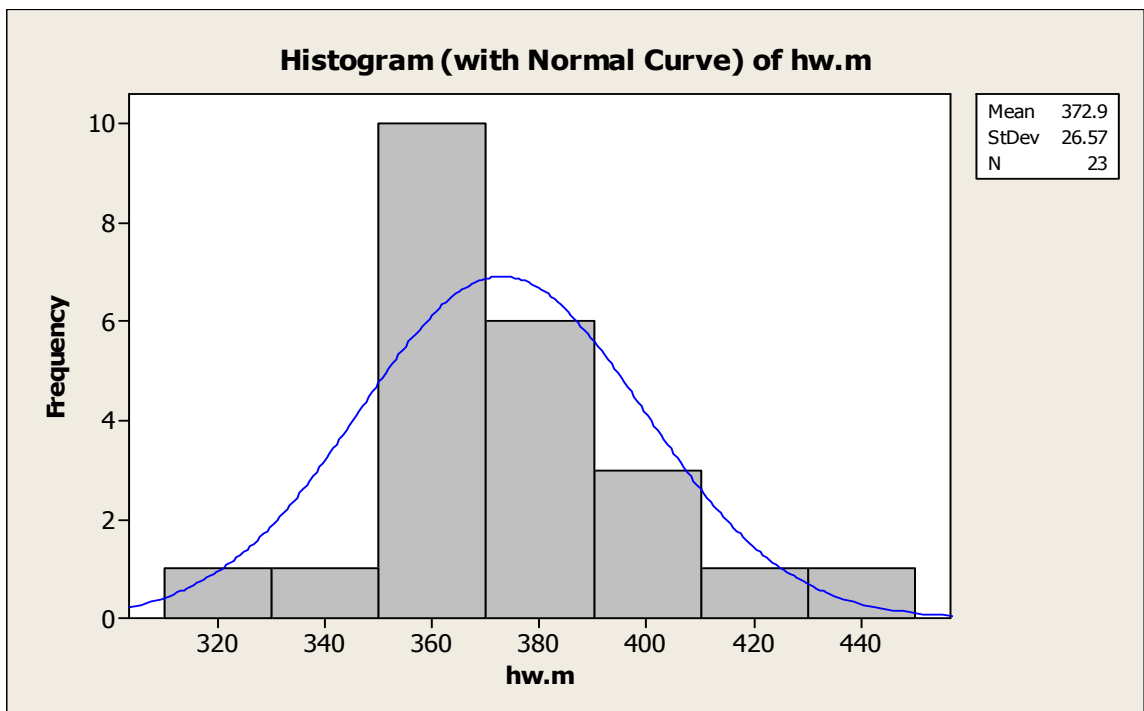

Figure B.19: Histogram of Male's Hip Breadth

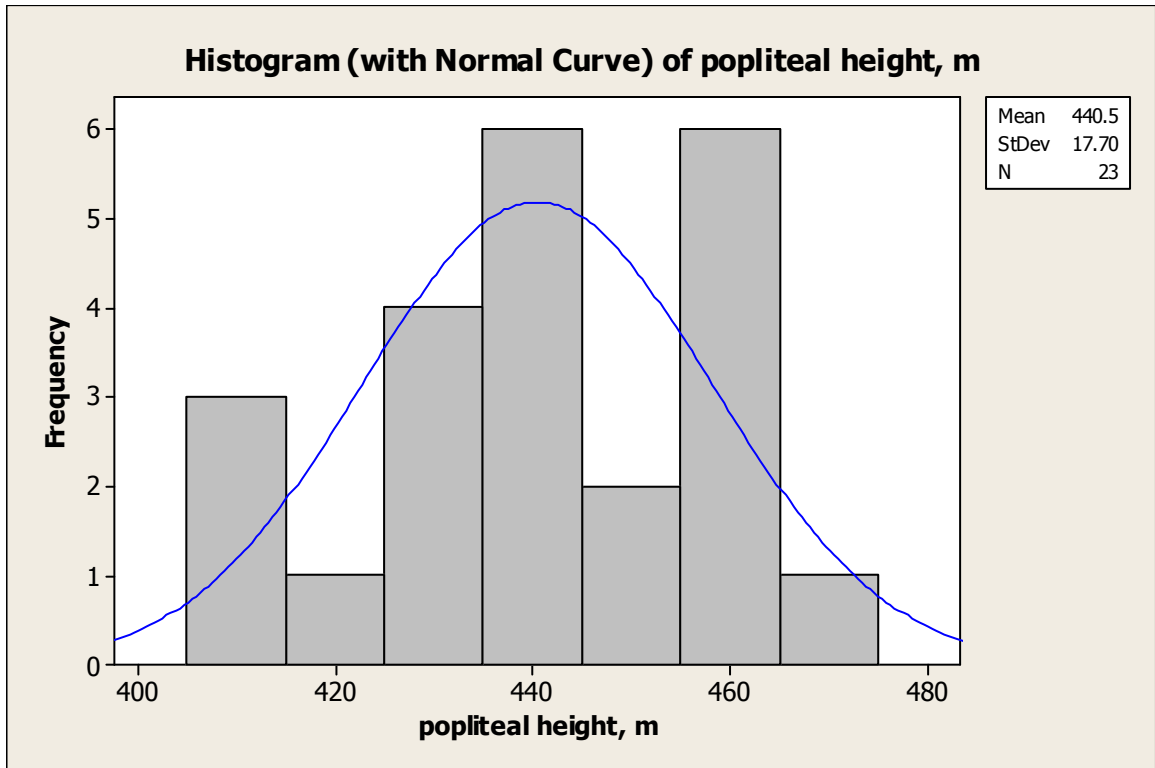

Figure B.20: Histogram of Male's popliteal Height

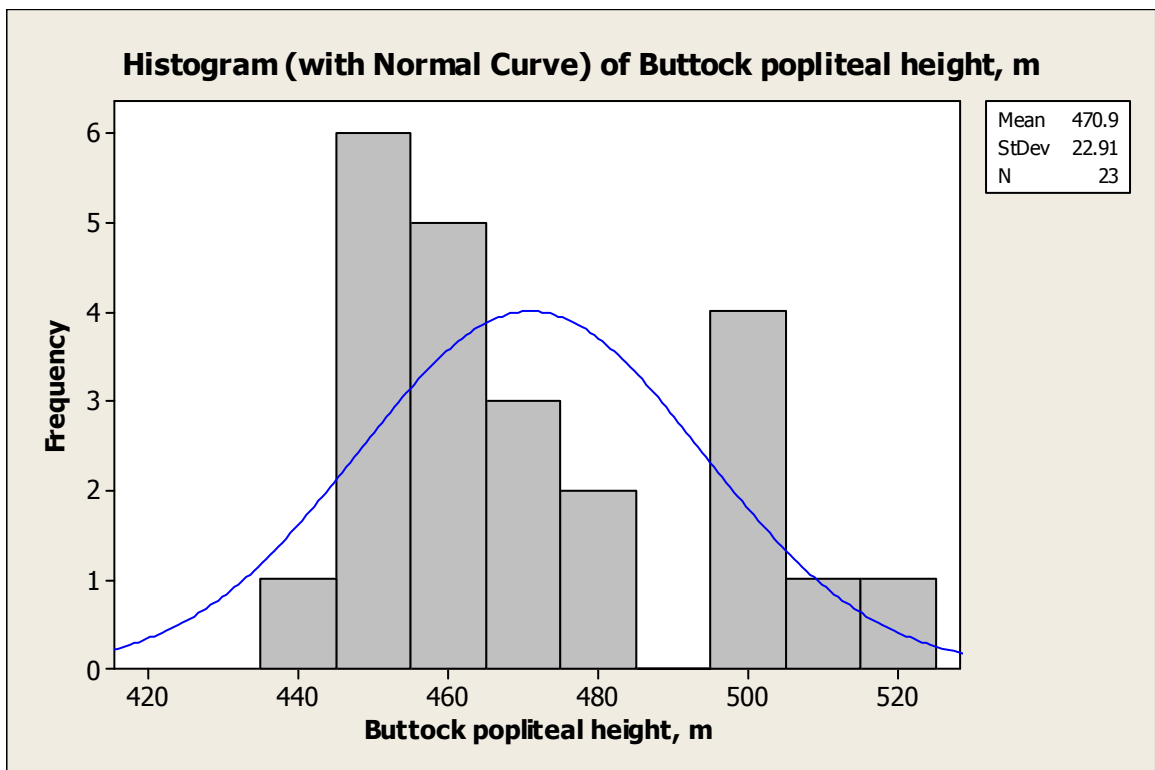

Figure B.21: Histogram of Male's Buttock Popliteal Length

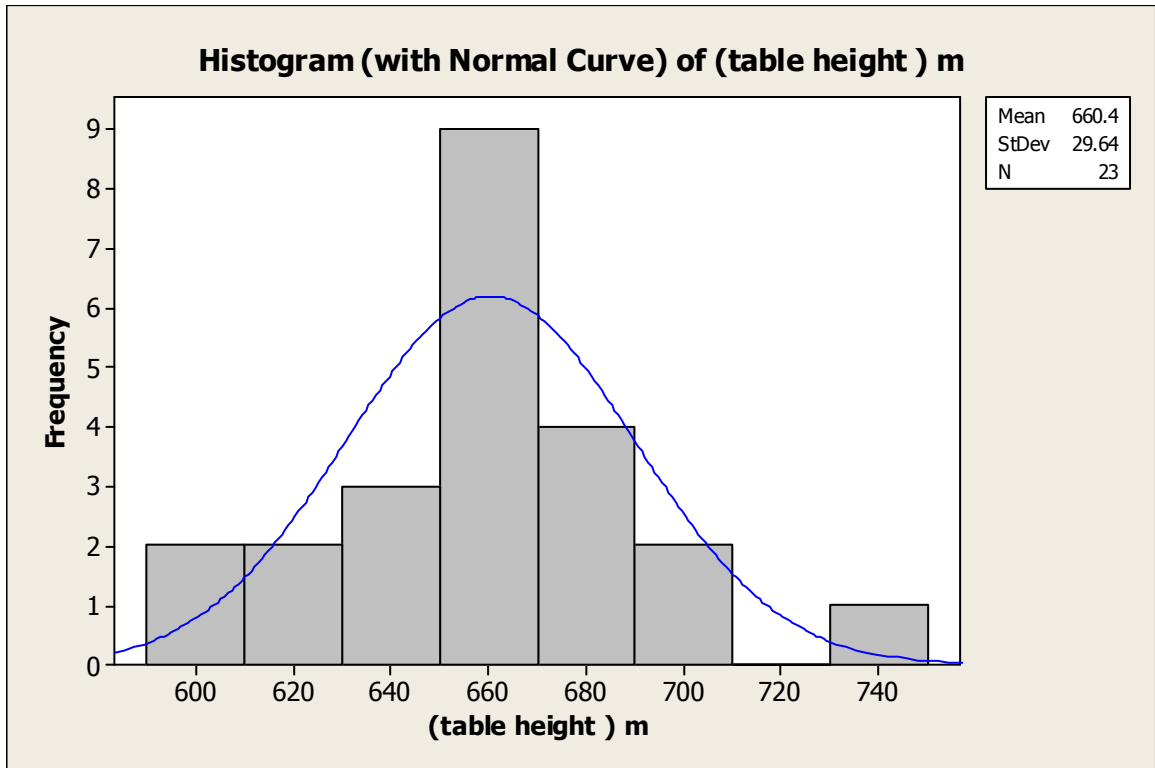

Figure B.22: Histogram of Male's Table Height

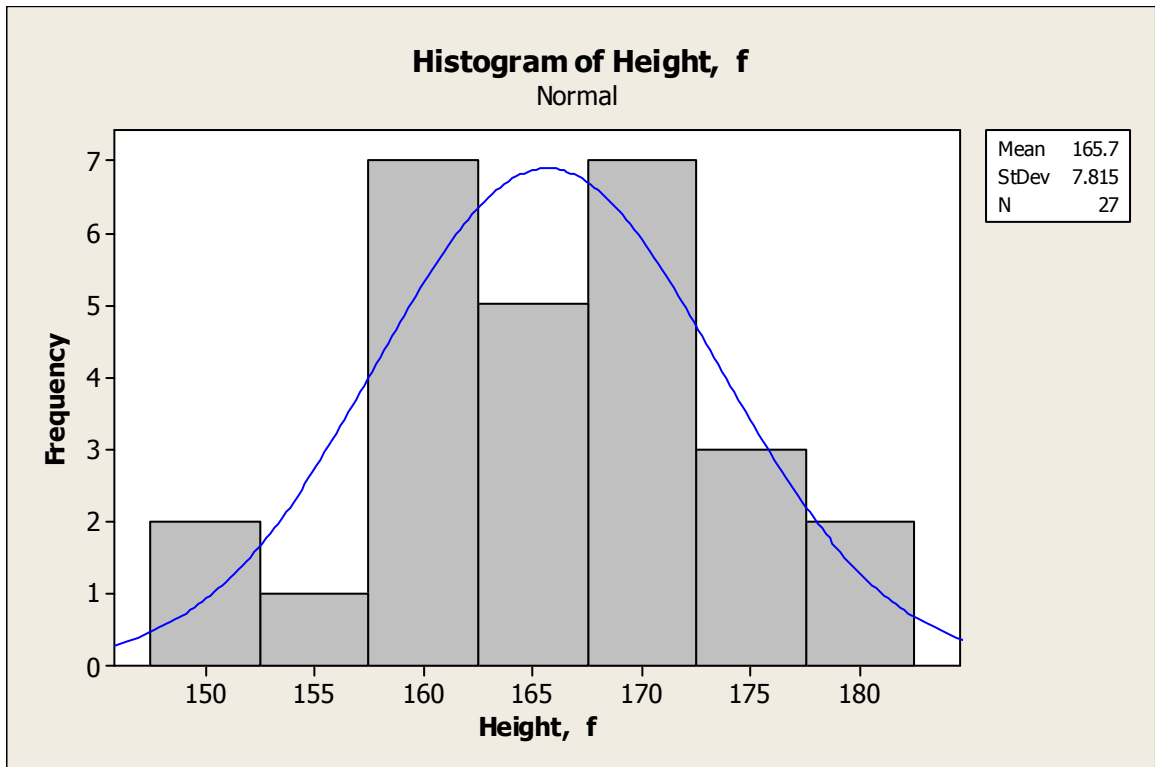

Figure B.23: Histogram of Female's Height

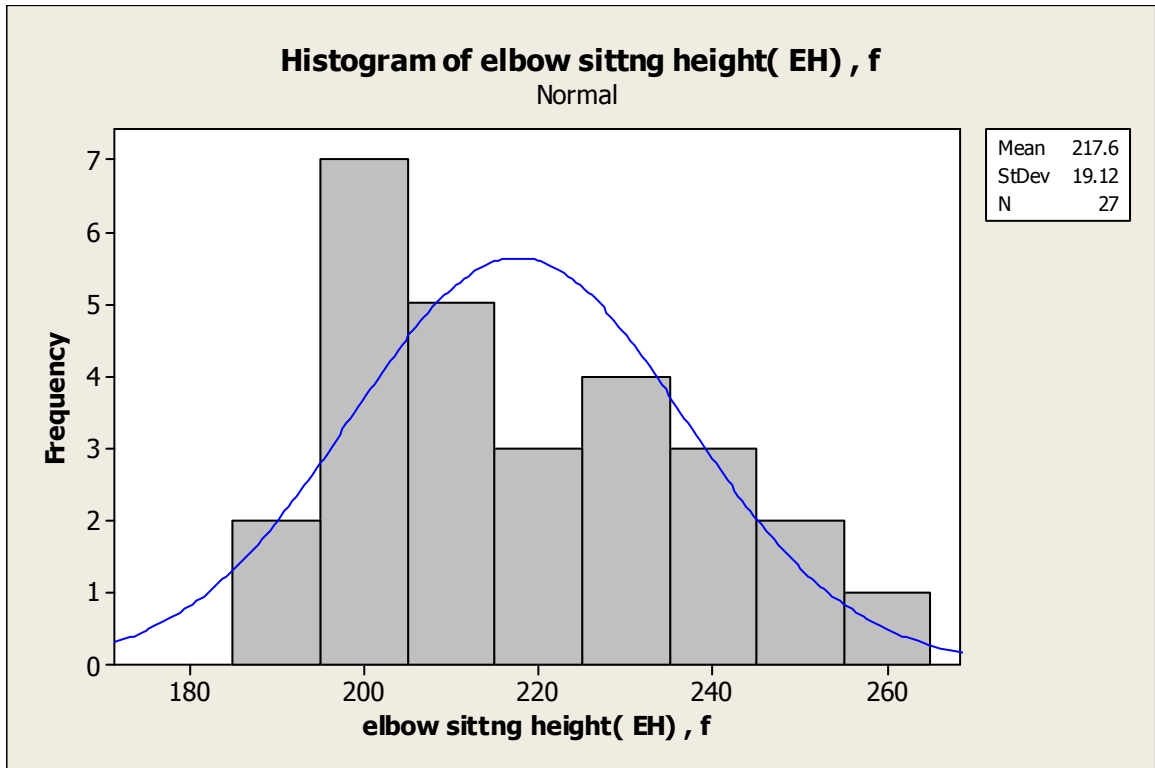

Figure B.24: Histogram of Female's Sitting Elbow Height

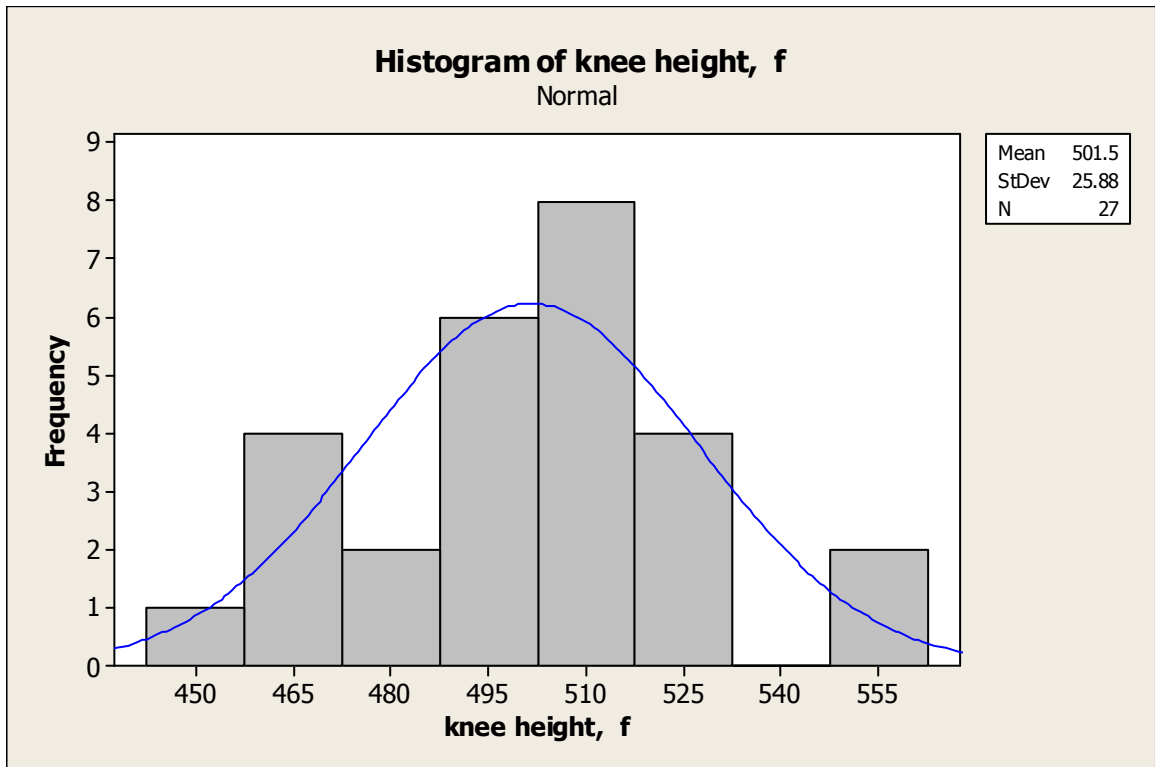

Figure B.25: Histogram of Female's Knee Height

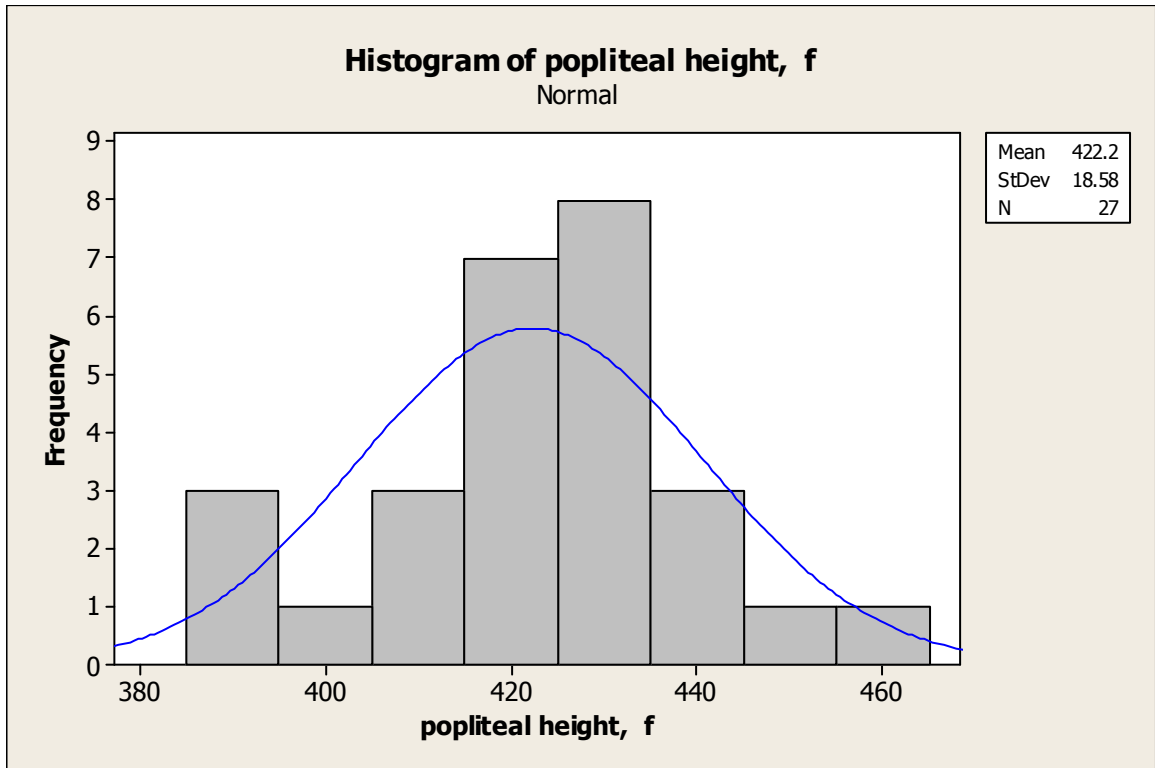

Figure B.26: Histogram of Female's Popliteal Height

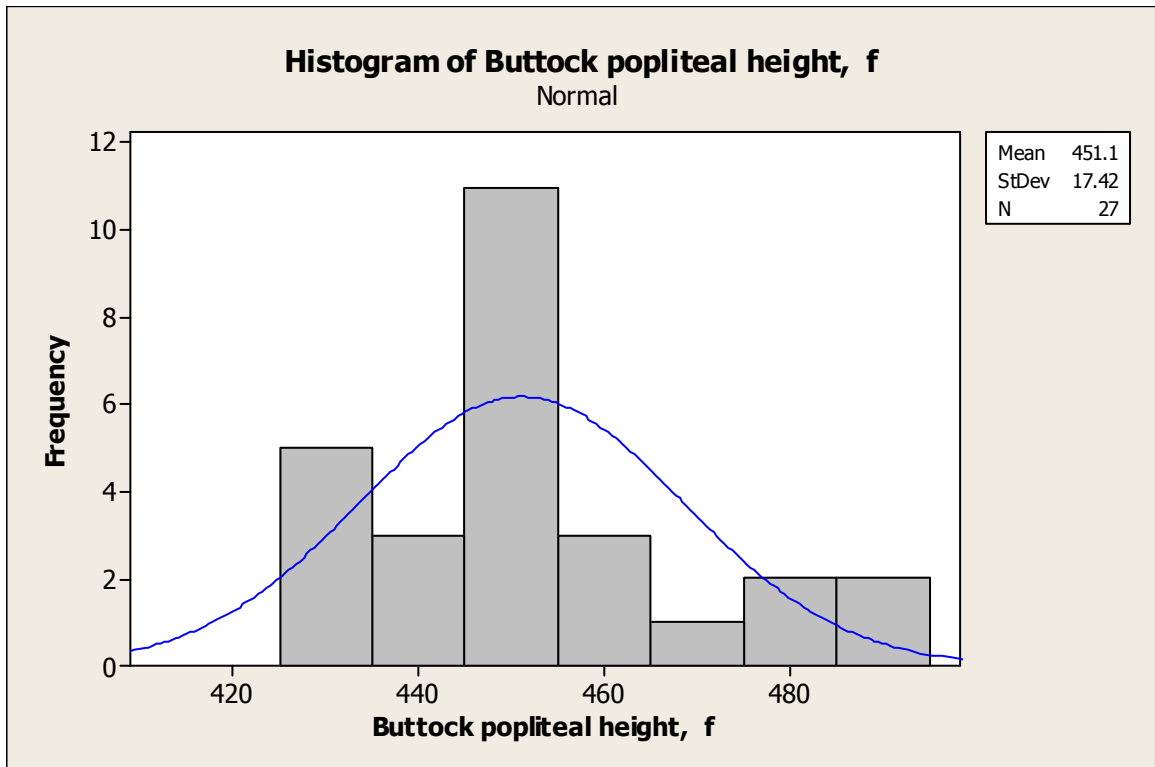

Figure B.27: Histogram of Female's Buttock Popliteal Length

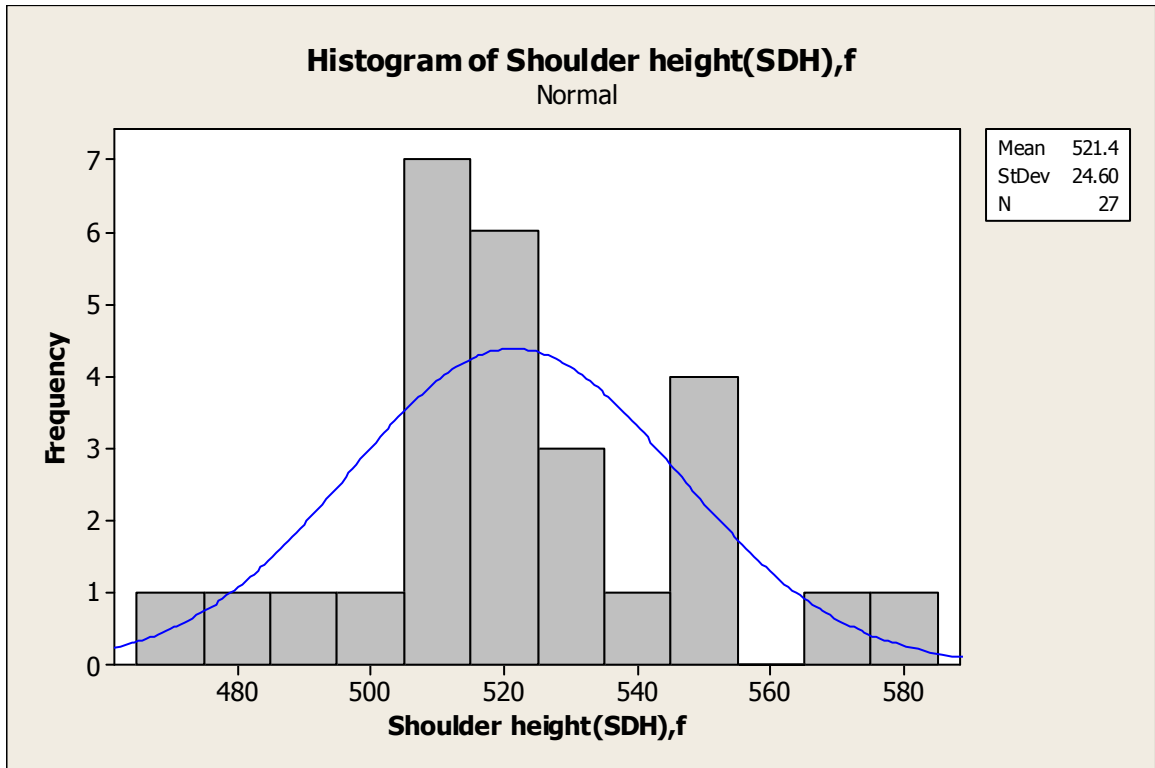

Figure B.28: Histogram of Female's Shoulder Height

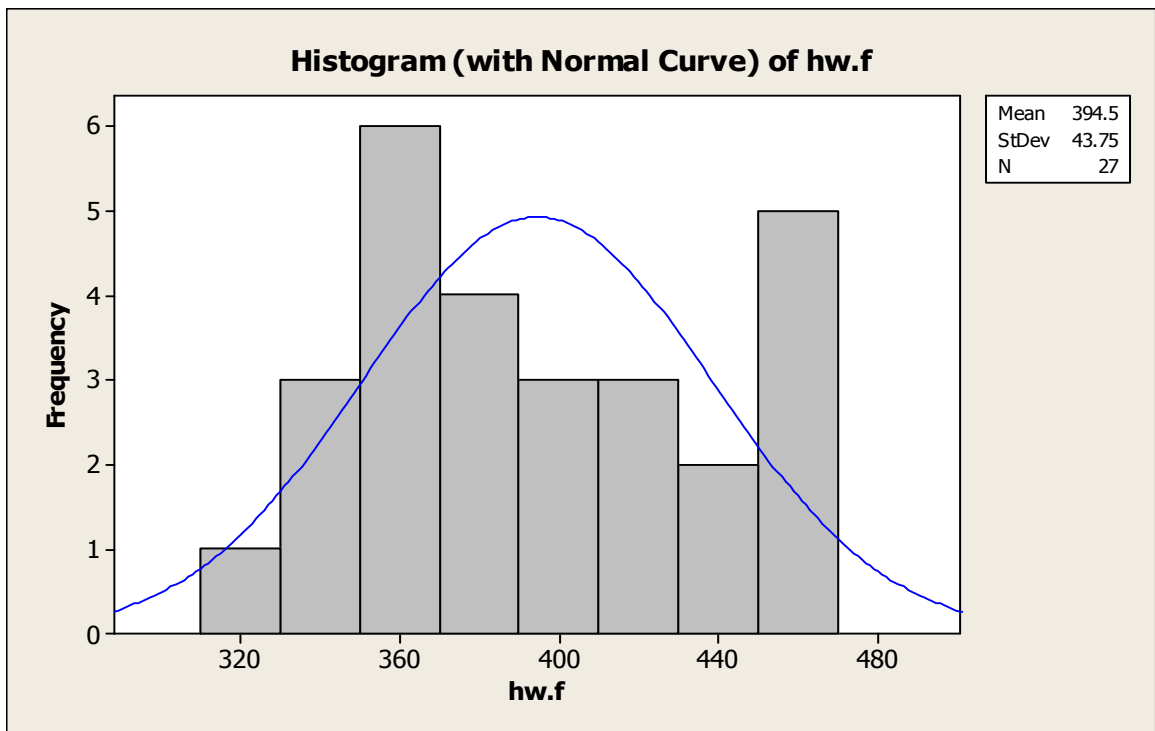

Figure B.29: Histogram of Female's Hip Breadth

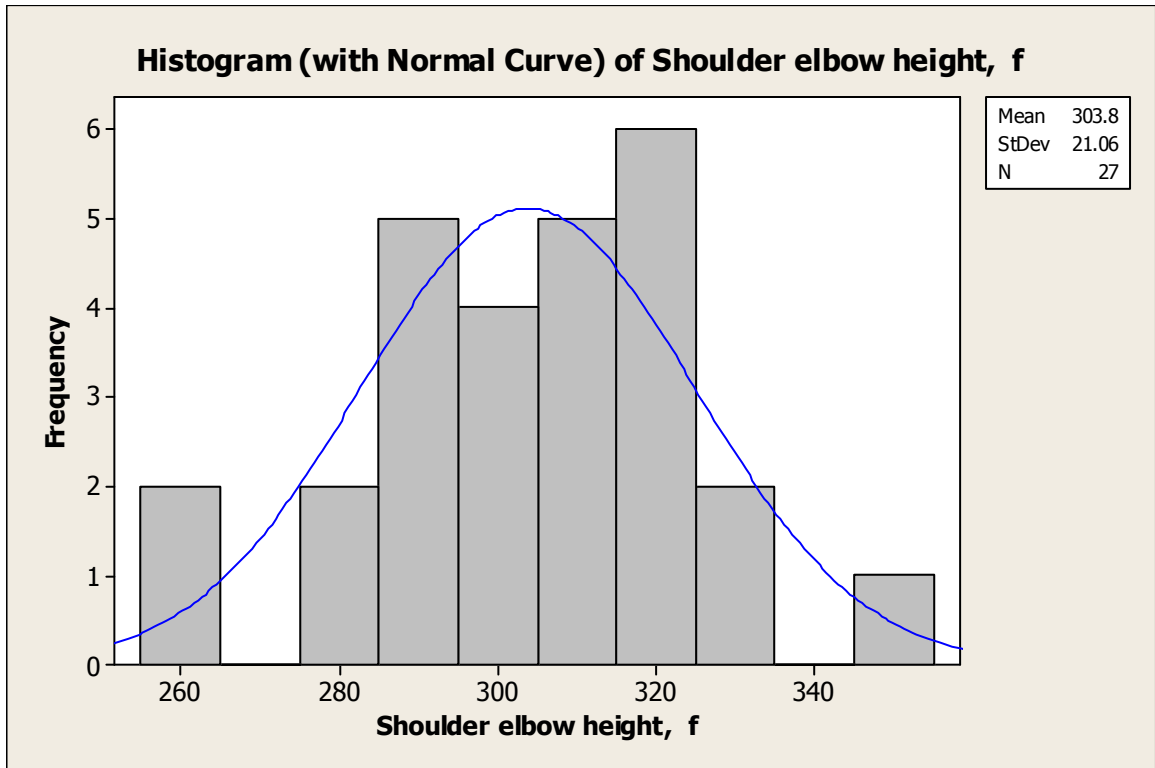

Figure B.30: Histogram of Female's Shoulder Elbow Height

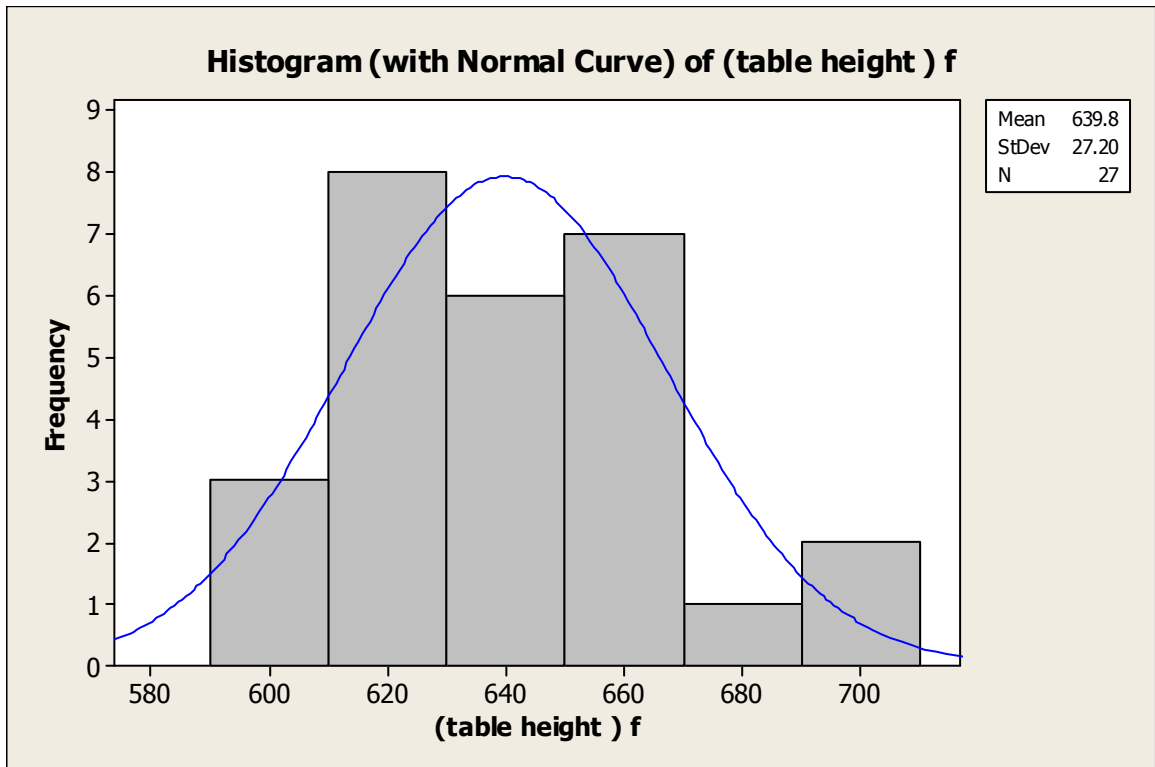

Figure B.31: Histogram of Female's Table Height

Appendix C: Results of Hypothesis Test by Minitab 14

3/9/2013 4:38:11 PM _____

Welcome to Minitab, press F1 for help.

Executing from file: C:\Users\Sony\Desktop\MINITAB
14\MACROS\STARTUP.MAC

This Software was purchased for academic use only.

Commercial use of the Software is prohibited.

Table C.1: Test for Equal Variances (student's height)

95% Bonferroni confidence intervals for standard deviations

Sample	N	Lower	StDev	Upper
1	23	3.80010	5.08920	7.6005
2	27	5.95591	7.81473	11.2406

F-Test (normal distribution)

Test statistic = 0.42, p-value = 0.045

Table C.2: Test for Equal Variances (Shoulder height , SDH)

95% Bonferroni confidence intervals for standard deviations

Sample	N	Lower	StDev	Upper
1	23	13.0732	17.5080	26.1475
2	27	18.7477	24.5988	35.3827

F-Test (normal distribution)

Test statistic = 0.51, p-value = 0.109

Table C.3: Test for Equal Variances (Shoulder elbow height)

95% Bonferroni confidence intervals for standard deviations

Sample	N	Lower	StDev	Upper
--------	---	-------	-------	-------

1 23 11.9572 16.0134 23.9155

2 27 16.0480 21.0566 30.2876

F-Test (normal distribution)

Test statistic = 0.58, p-value = 0.196

Table C.4: Test for Equal Variances (Buttock popliteal length)

95% Bonferroni confidence intervals for standard deviations

Sample	N	Lower	StDev	Upper
--------	---	-------	-------	-------

1	23	17.1088	22.9127	34.2192
---	----	---------	---------	---------

2	27	13.2731	17.4156	25.0504
---	----	---------	---------	---------

F-Test (normal distribution)

Test statistic = 1.73, p-value = 0.181

Table C.5: Test for Equal Variances (popliteal height)

95% Bonferroni confidence intervals for standard deviations

Sample	N	Lower	StDev	Upper
--------	---	-------	-------	-------

1	23	13.2159	17.6992	26.4330
---	----	---------	---------	---------

2	27	14.1593	18.5784	26.7230
---	----	---------	---------	---------

F-Test (normal distribution)

Test statistic = 0.91, p-value = 0.824

Table C.6: Test for Equal Variances (knee height)

95% Bonferroni confidence intervals for standard deviations

Sample	N	Lower	StDev	Upper
--------	---	-------	-------	-------

1	23	13.9413	18.6706	27.8838
---	----	---------	---------	---------

2 27 19.7256 25.8818 37.2282

F-Test (normal distribution)

Test statistic = 0.52, p-value = 0.124

Table C.7: Test for Equal Variances (elbowsitting height EH)

95% Bonferroni confidence intervals for standard deviations

Sample	N	Lower	StDev	Upper
--------	---	-------	-------	-------

1	23	12.4620	16.6895	24.9252
---	----	---------	---------	---------

2	27	14.5716	19.1193	27.5011
---	----	---------	---------	---------

F-Test (normal distribution)

Test statistic = 0.76, p-value = 0.521

Table C.8 Test for Equal Variances (Hip breadth)

95% Bonferroni confidence intervals for standard deviations

Sample	N	Lower	StDev	Upper
--------	---	-------	-------	-------

1	23	19.8262	26.5518	39.6542
---	----	---------	---------	---------

2	27	33.3426	43.7487	62.9277
---	----	---------	---------	---------

F-Test (normal distribution)

Test statistic = 0.37, p-value = 0.020

Table C.9: Two-Sample T-Test and CI (Shoulder height, SDH)

Sample	N	Mean	StDev	SE Mean
--------	---	------	-------	---------

1	23	551.5	17.5	3.7
---	----	-------	------	-----

2	27	521.4	24.6	4.7
---	----	-------	------	-----

Difference = mu (1) - mu (2)

Estimate for difference: 30.1200

95% CI for difference: (17.7770, 42.4630)

T-Test of difference = 0 (vs not =): T-Value = 4.91 P-Value = 0.000 DF = 48

Both use Pooled StDev = 21.6345

Table C. 10: Two-Sample T-Test and CI (Shoulder elbow height)

Sample	N	Mean	StDev	SE Mean
1	23	331.6	16.0	3.3
2	27	303.8	21.1	4.1

Difference = mu (1) - mu (2)

Estimate for difference: 27.8100

95% CI for difference: (17.0201, 38.5999)

T-Test of difference = 0 (vs not =): T-Value = 5.18 P-Value = 0.000 DF = 48

Both use Pooled StDev = 18.9123

Table C.11: Two-Sample T-Test and CI (Buttock popliteal length)

Sample	N	Mean	StDev	SE Mean
1	23	470.9	22.9	4.8
2	27	451.1	17.4	3.4

Difference = mu (1) - mu (2)

Estimate for difference: 19.8400

95% CI for difference: (8.3588, 31.3212)

T-Test of difference = 0 (vs not =): T-Value = 3.47 P-Value = 0.001 DF = 48

Both use Pooled StDev = 20.1241

Table C.12: Two-Sample T-Test and CI (popliteal height)

Sample	N	Mean	StDev	SE Mean
--------	---	------	-------	---------

1	23	440.5	17.7	3.7
---	----	-------	------	-----

2	27	422.2	18.6	3.6
---	----	-------	------	-----

Difference = mu (1) - mu (2)

Estimate for difference: 18.2850

95% CI for difference: (7.9152, 28.6548)

T-Test of difference = 0 (vs not =): T-Value = 3.55 P-Value = 0.001 DF = 48

Both use Pooled StDev = 18.1760

Table C.13: Two-Sample T-Test and CI (knee height)

Sample	N	Mean	StDev	SE Mean
--------	---	------	-------	---------

1	23	530.0	18.7	3.9
---	----	-------	------	-----

2	27	510.5	25.9	5.0
---	----	-------	------	-----

Difference = mu (1) - mu (2)

Estimate for difference: 19.4300

95% CI for difference: (6.3882, 32.4718)

T-Test of difference = 0 (vs not =): T-Value = 3.00 P-Value = 0.004 DF = 48

Both use Pooled StDev = 22.8595

Table C. 14: Two-Sample T-Test and CI , inequality variance (hip width)

Sample	N	Mean	StDev	SE Mean
--------	---	------	-------	---------

1	23	372.9	26.6	5.5
---	----	-------	------	-----

2	27	394.5	43.8	8.4
---	----	-------	------	-----

Difference = mu (1) - mu (2)

Estimate for difference: -21.6055

95% CI for difference: (-41.9316, -1.2793)

T-Test of difference = 0 (vs not =): T-Value = -2.14 P-Value = 0.038 DF = 43

Table C.15: Two-Sample T-Test and CI (Height inequality variance)

Sample	N	Mean	StDev	SE Mean
1	23	175.91	5.09	1.1
2	27	165.68	7.81	1.5

Difference = mu (1) - mu (2)

Estimate for difference: 10.2350

5% CI for difference: (10.1190, 10.3510)

T-Test of difference = 0 (vs not =): T-Value = 5.56 P-Value = 0.000 DF = 45

Table C. 16: Two-Sample T-Test and CI (elbow sitting height)

Sample	N	Mean	StDev	SE Mean
1	23	219.9	16.7	3.5
2	27	217.6	19.1	3.7

Difference = mu (1) - mu (2)

Estimate for difference: 2.28341

95% CI for difference: (-8.01240, 12.57923)

T-Test of difference = 0 (vs not =): T-Value = 0.45 P-Value = 0.658 DF = 48

Both use Pooled StDev = 18.0463

Table C.17: Test for Equal Variances: (table height) m, (table height) f

95% Bonferroni confidence intervals for standard deviations

	N	Lower	StDev	Upper
(table height) m	23	22.1286	29.6353	44.2591
(table height) f	27	20.7271	27.1959	39.1183

F-Test (normal distribution)

Test statistic = 1.19, p-value = 0.669

Table C.18: Two-Sample T-Test and CI: (table height) m, (table height) f

Two-sample T for (table height) m vs (table height) f

	N	Mean	StDev	SE Mean
(table height)	23	660.4	29.6	6.2
(table height)	27	639.8	27.2	5.2

Difference = mu ((table height) m) - mu ((table height) f)

Estimate for difference: 20.5765

95% lower bound for difference: 7.0890

T-Test of difference = 0 (vs>): T-Value = 2.56 P-Value = 0.007 DF = 48

Both use Pooled StDev = 28.3400

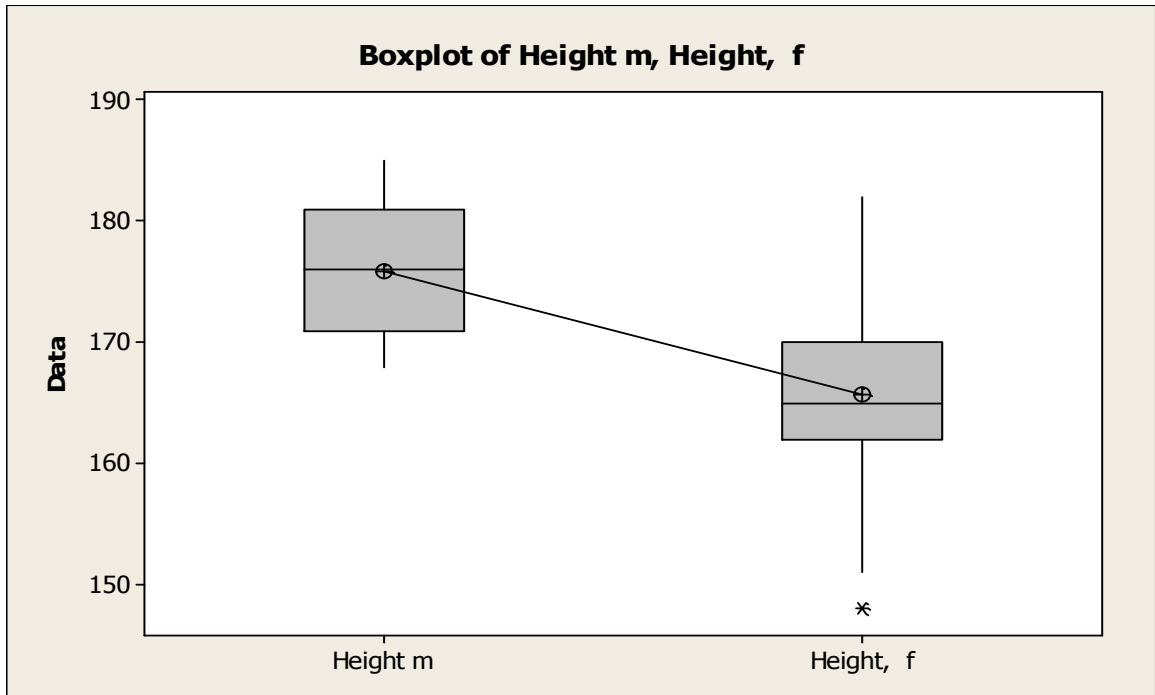

Figure C.1: Boxplot of Height for Both Male and Female

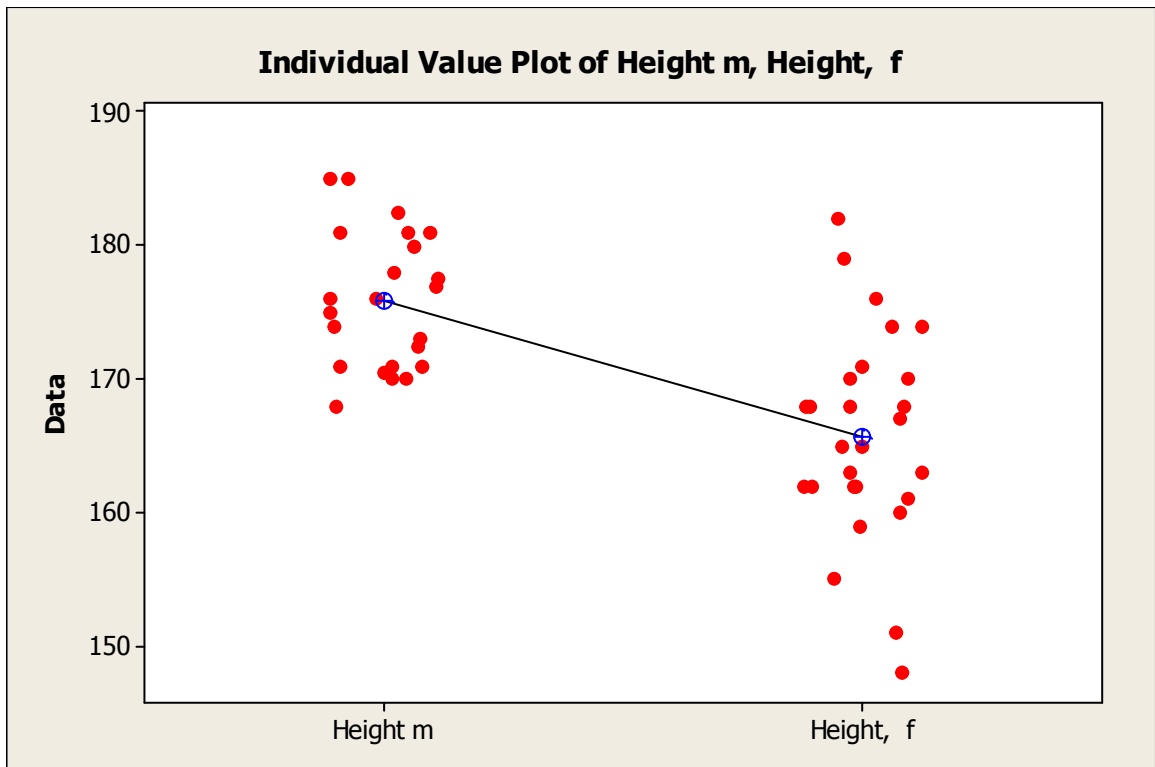

Figure C.2: Individual Value Plot of Height for Both Male and Female



Figure C.3: Boxplot of Sitting Elbow Height for Both Male and Female

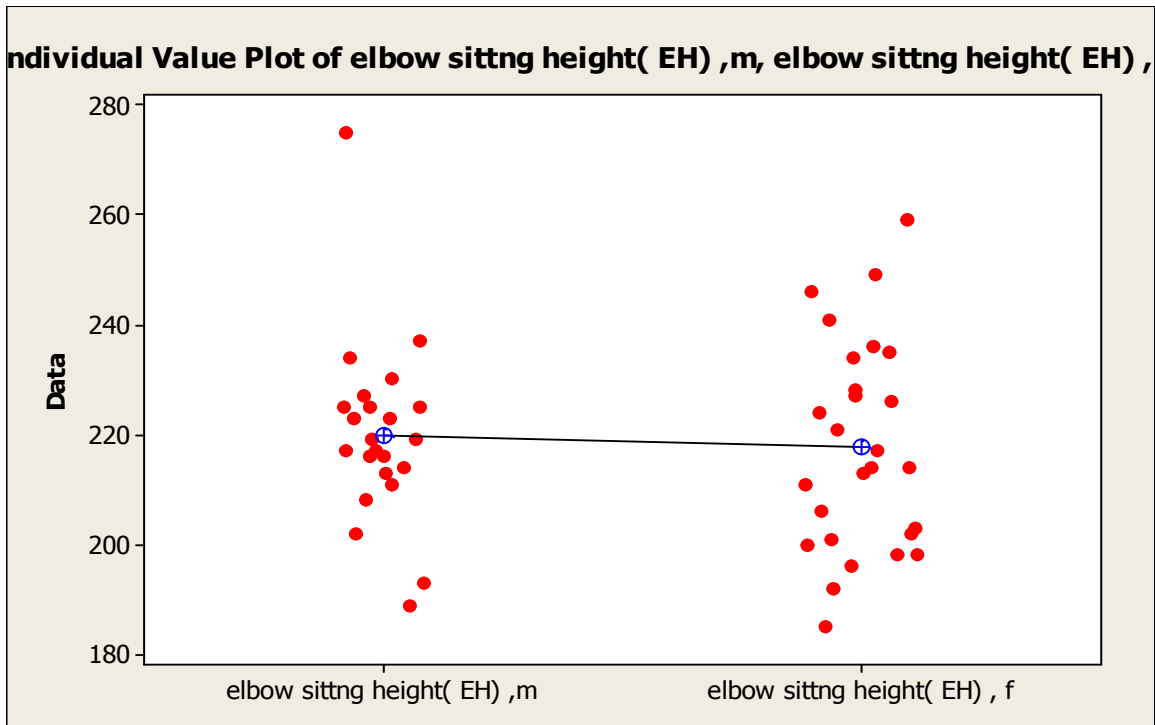

Figure C.4: Individual Value plot of Elbow Sitting Height for Both Male and Female

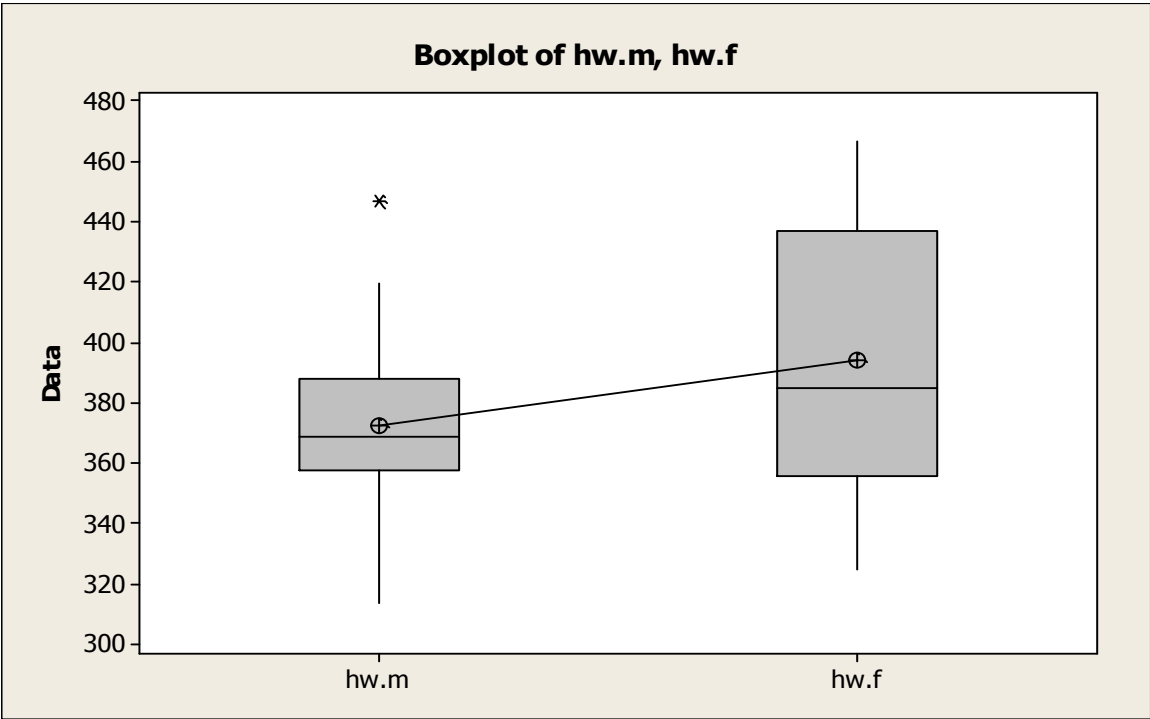

Figure C.5: Boxplot of Hip Breadth for Both Male and Female

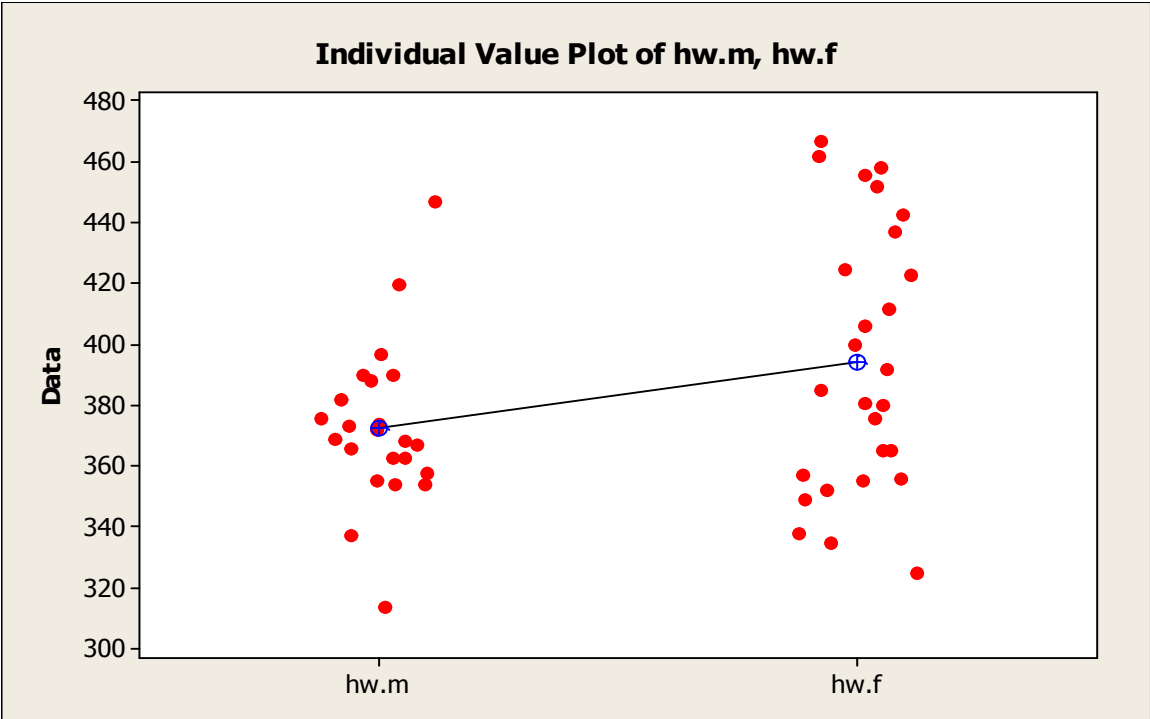

Figure C.6: Individual Value Plot Hip Breadth

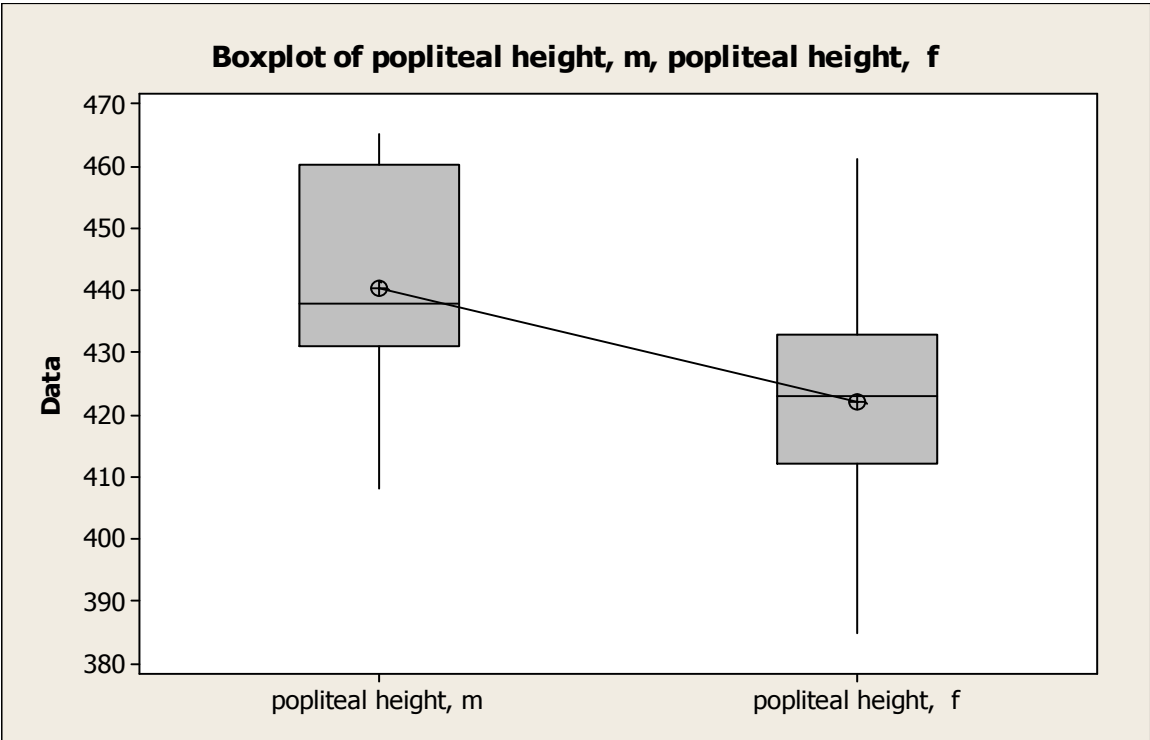

Figure C.7: Boxplot of Popliteal Height for Both Male and Female

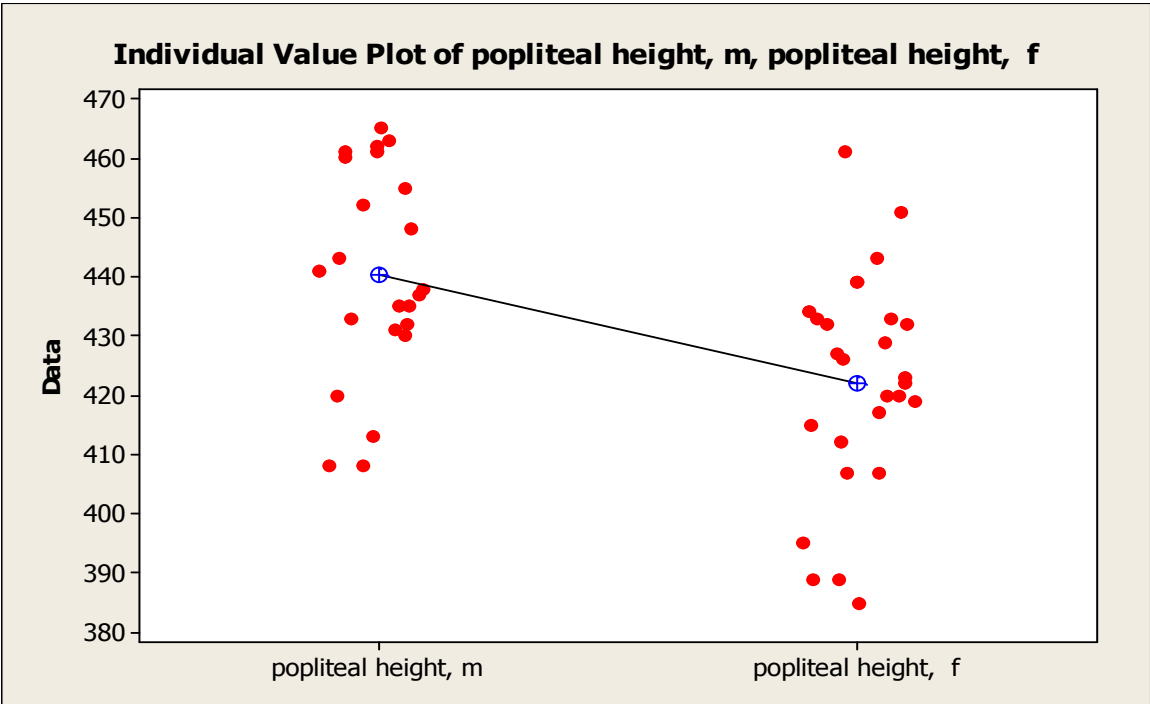

Figure C.8: Individual Value Plot of Popliteal Height

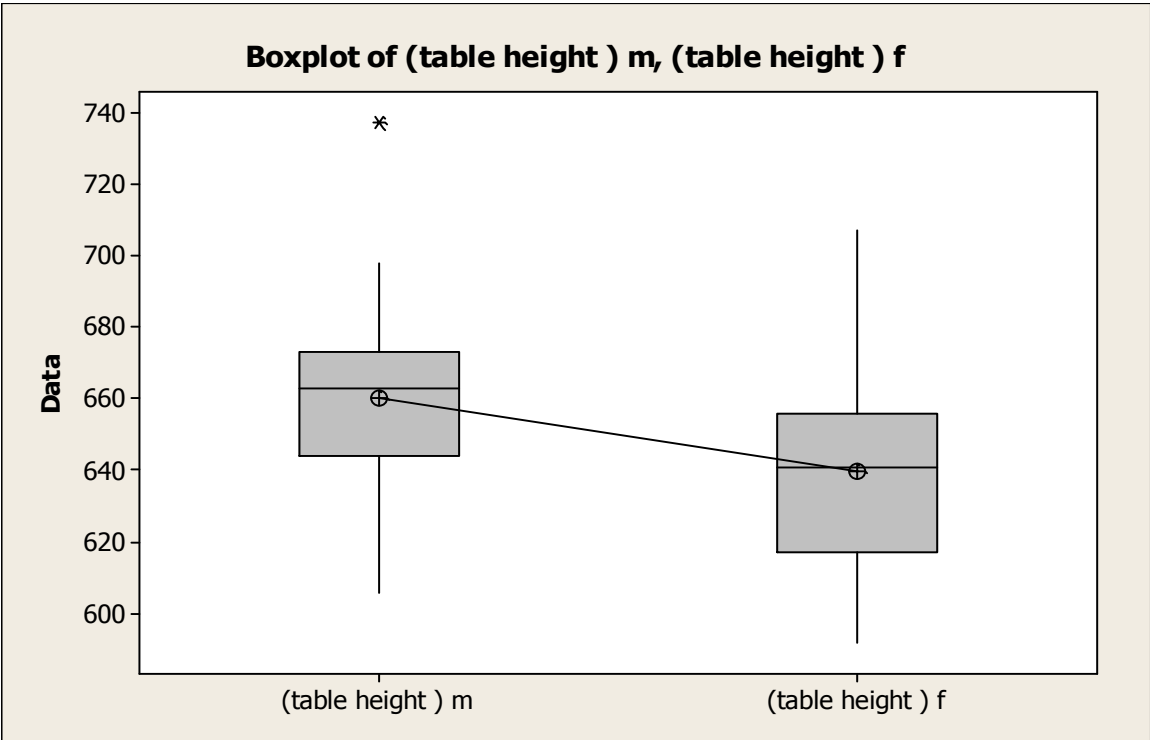

Figure C.9: Boxplot of Table Height for Both Male and Female

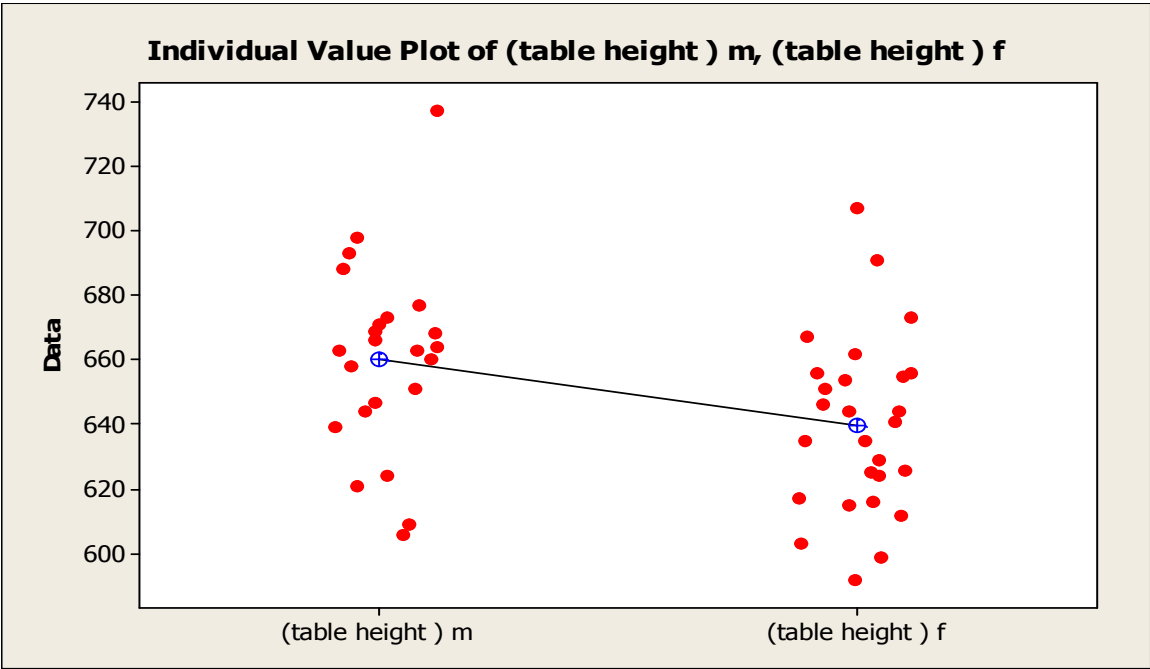

Figure C.10: Individual Value Plot of Table Height

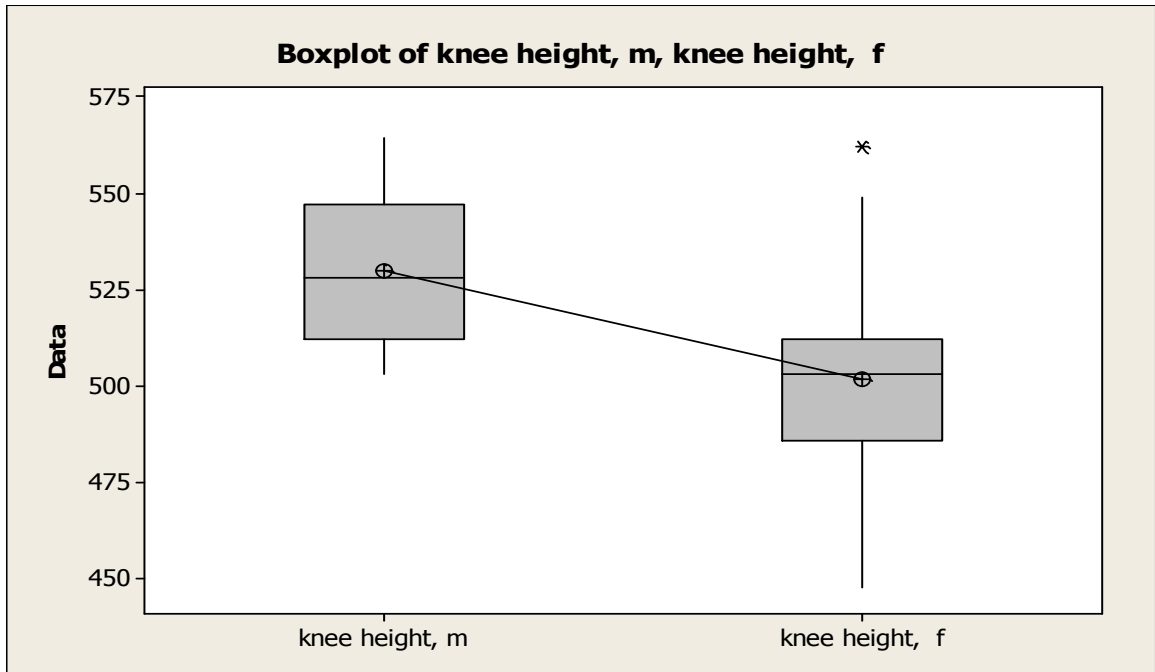

Figure C.11: Boxplot of Knee Height for both Male and Female

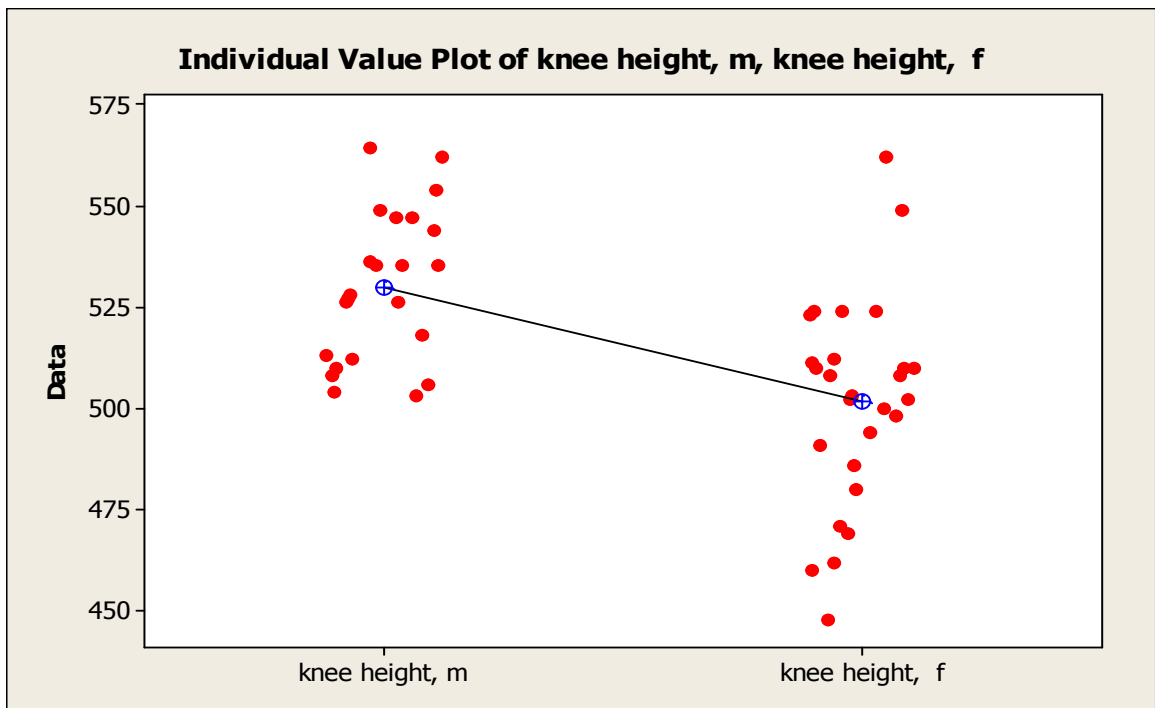

Figure C.12: Individual Value Plot of Knee height for Both Male and Female

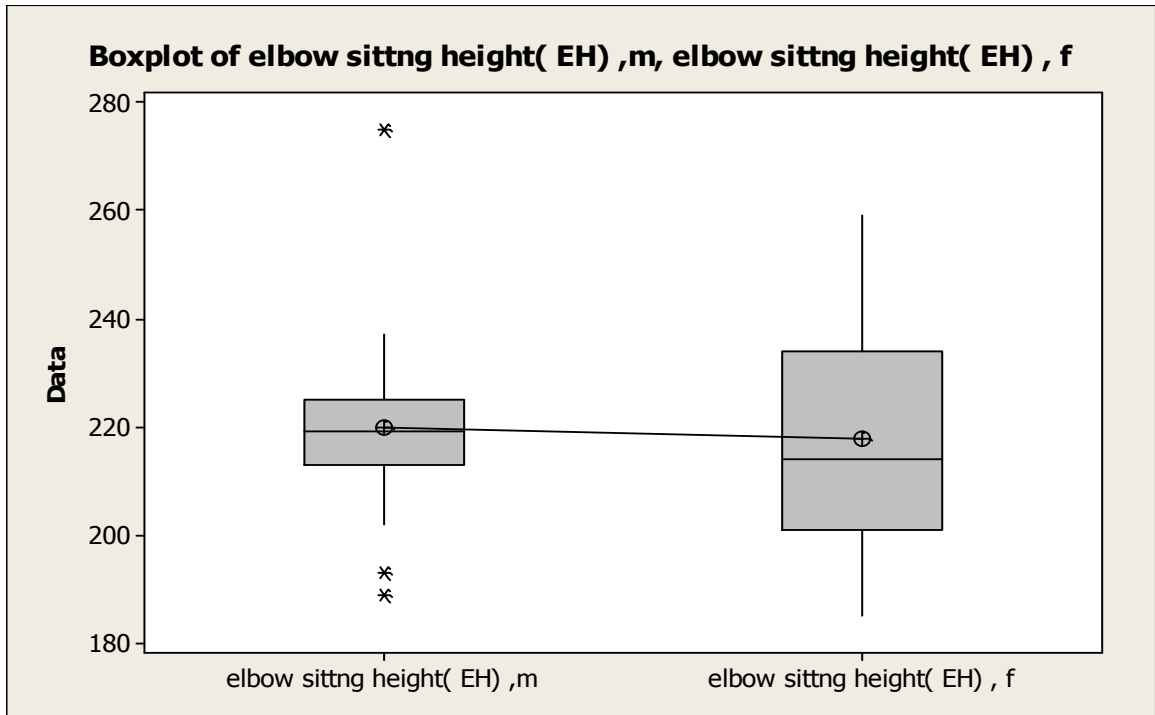

Figure C.13: Boxplot of Sitting Elbow Height for Both Male and Female

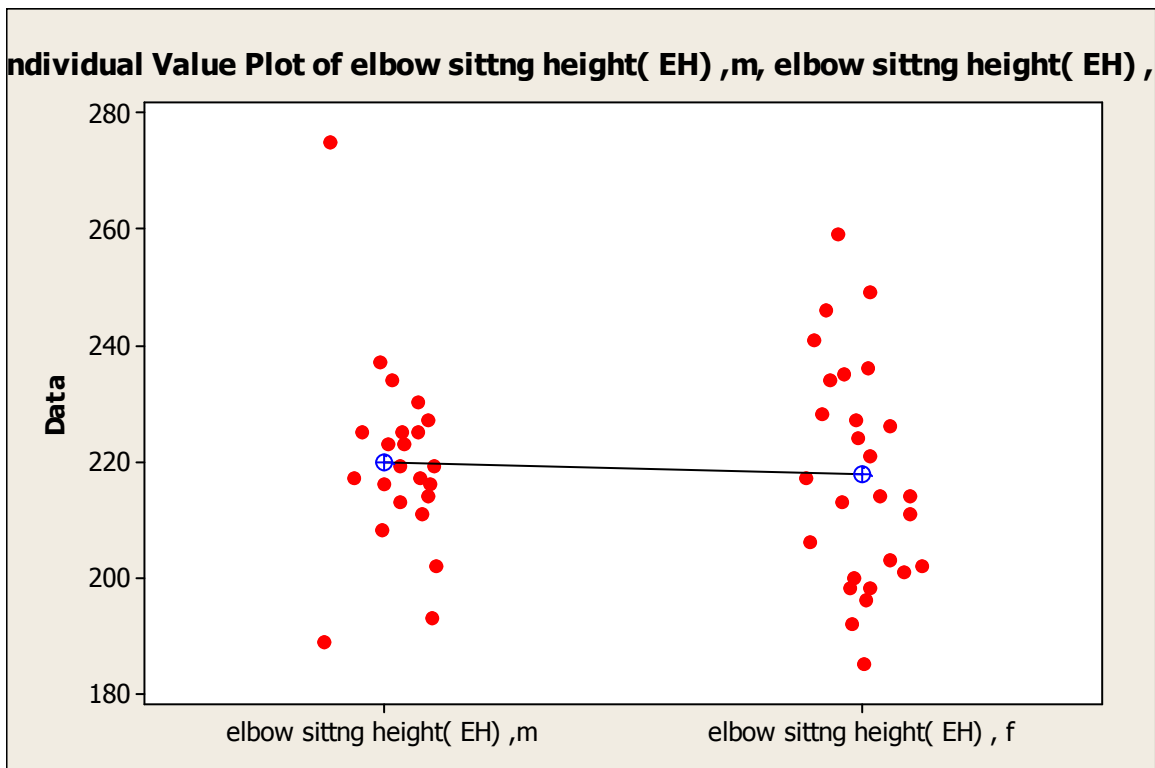

Figure C.14: Individual Value Plot of Elbow Sitting Height

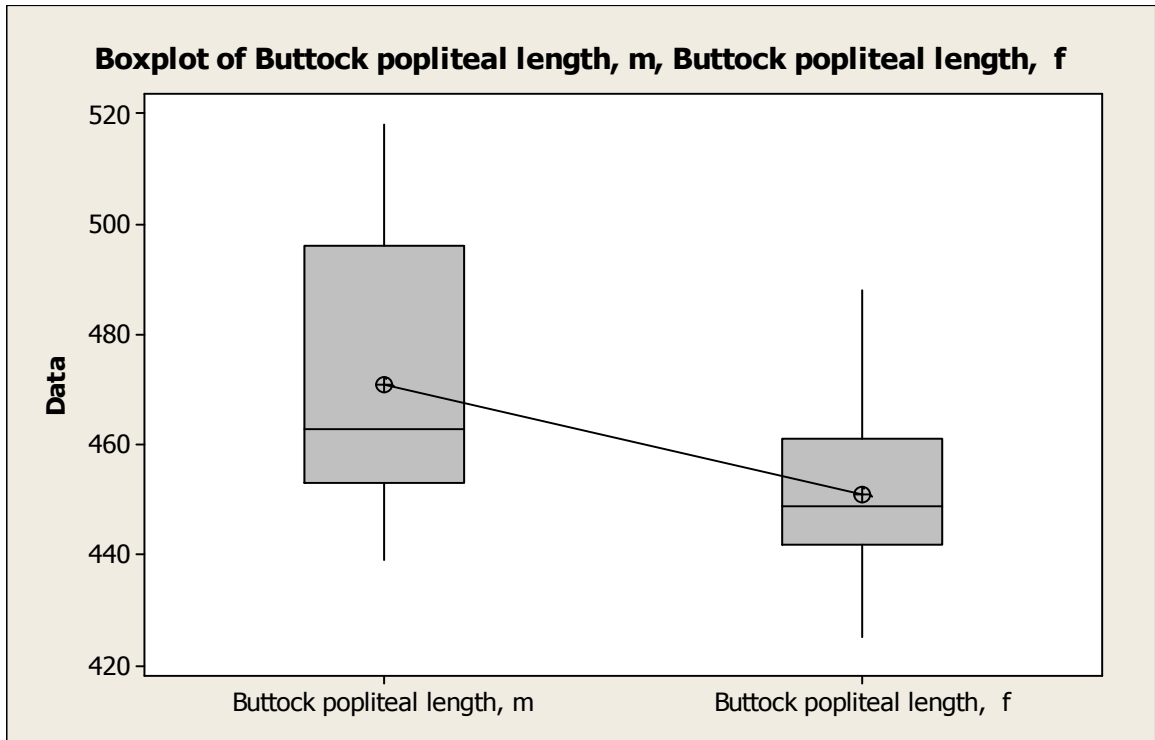

Figure C.15: Boxplot of Buttock Popliteal Length for Both Male and Female

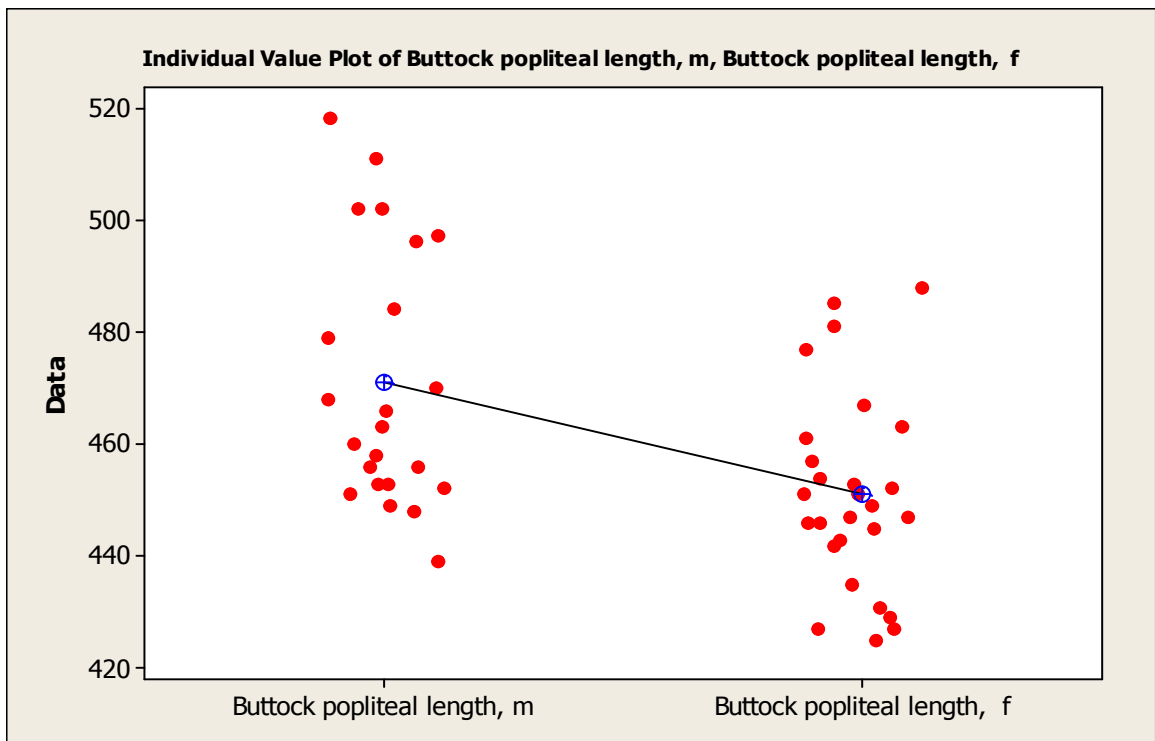

Figure C.16: Individual Value Plot of Buttock Popliteal Length

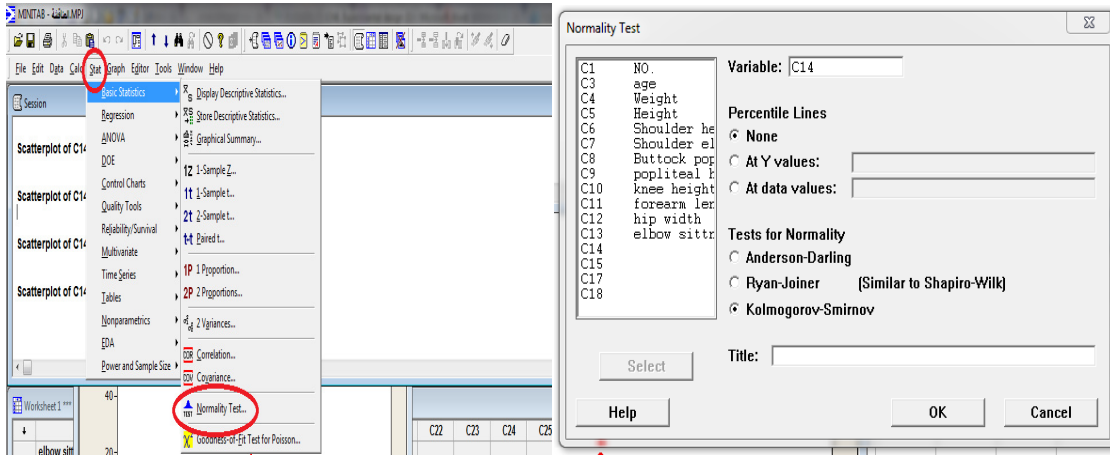

Figure C.17: The Normality Test by Minitab14

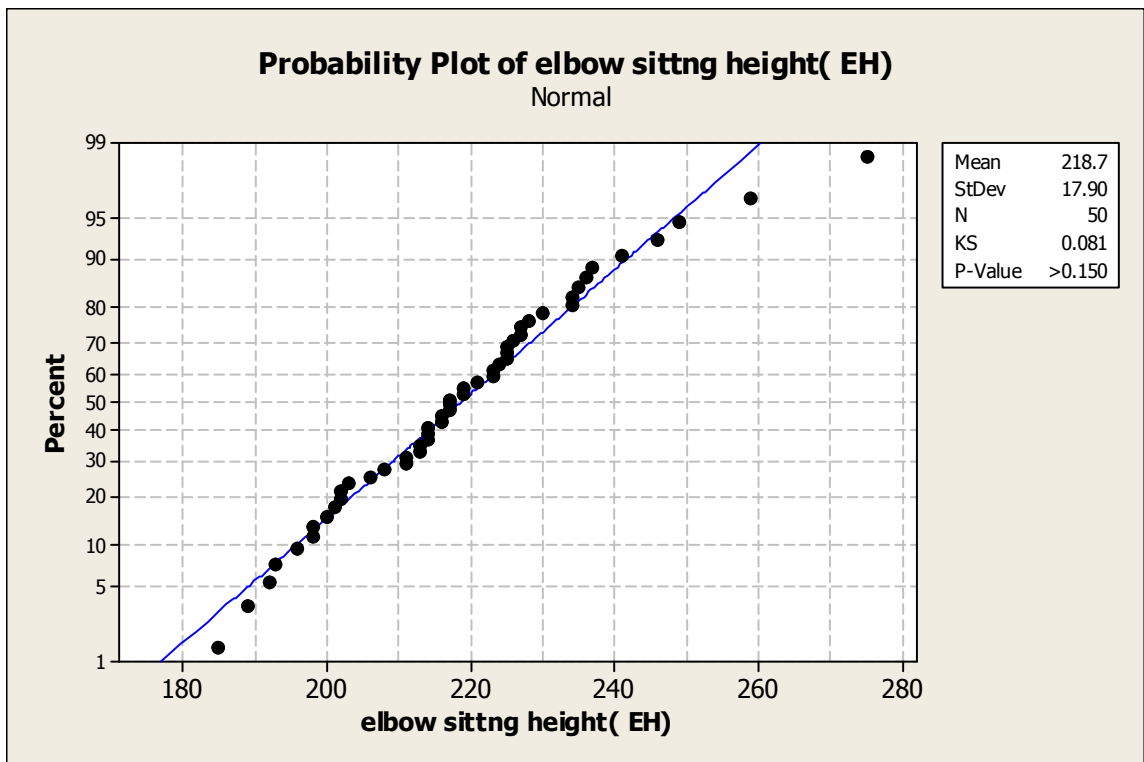

Figure C.18: Normal Probability Plot of Elbow Sitting Height

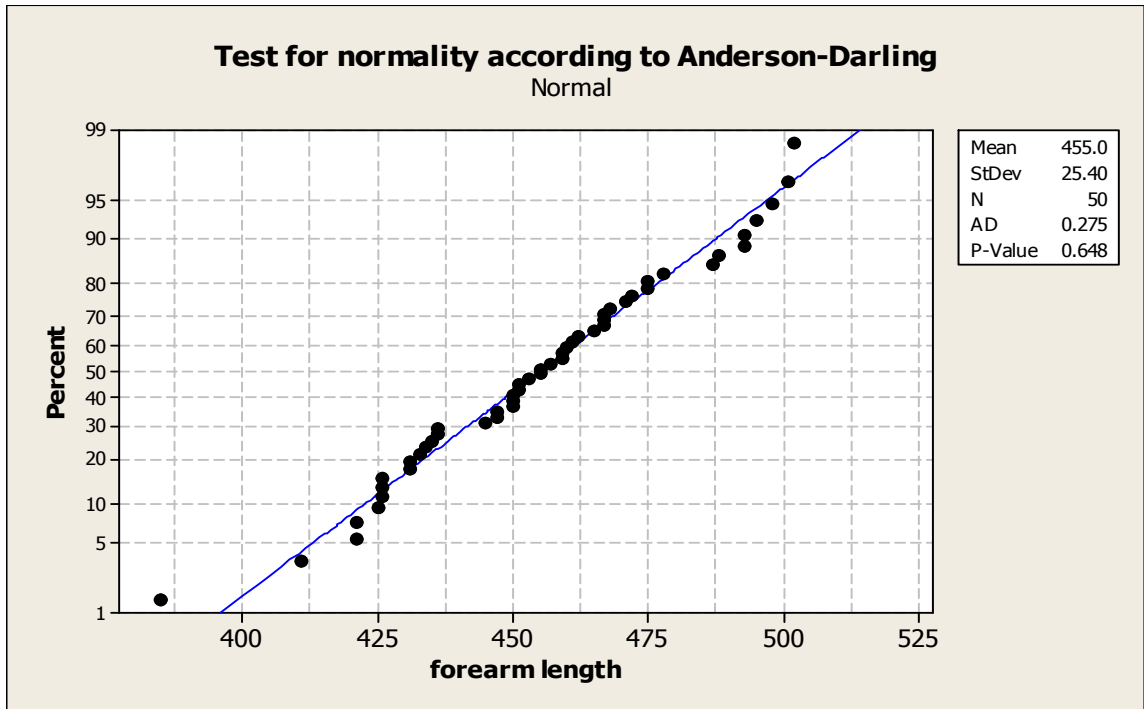

Figure C.19: Normal Probability Plot of Forearm Length

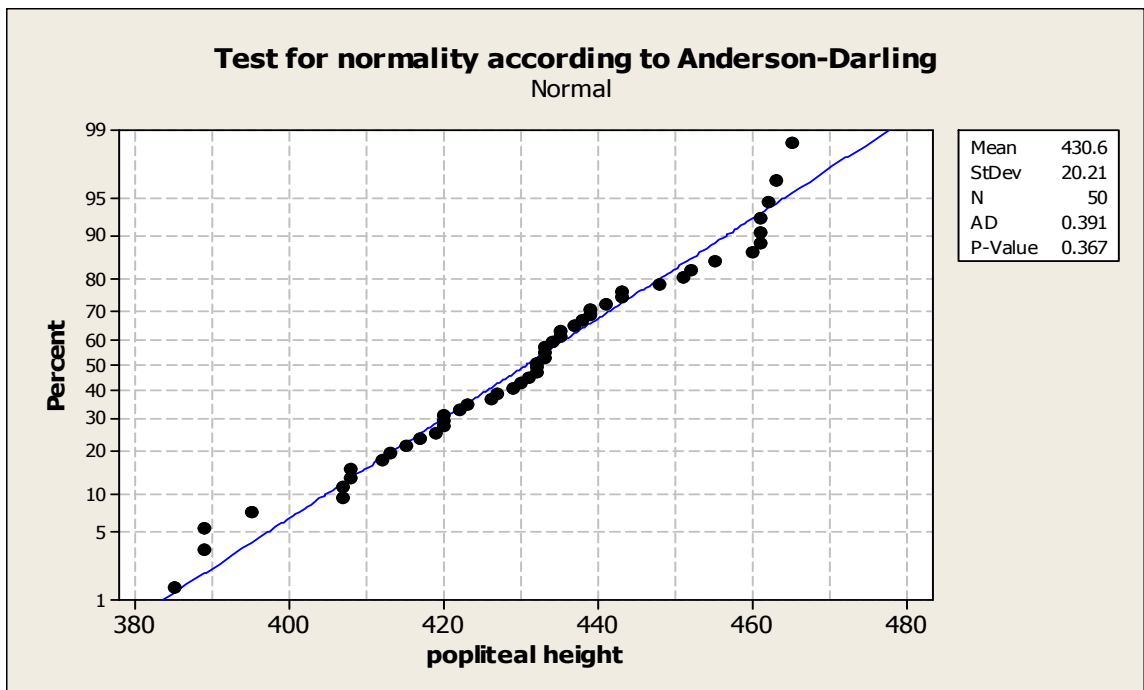

Figure C.20: Normal Probability Plot of Popliteal Height

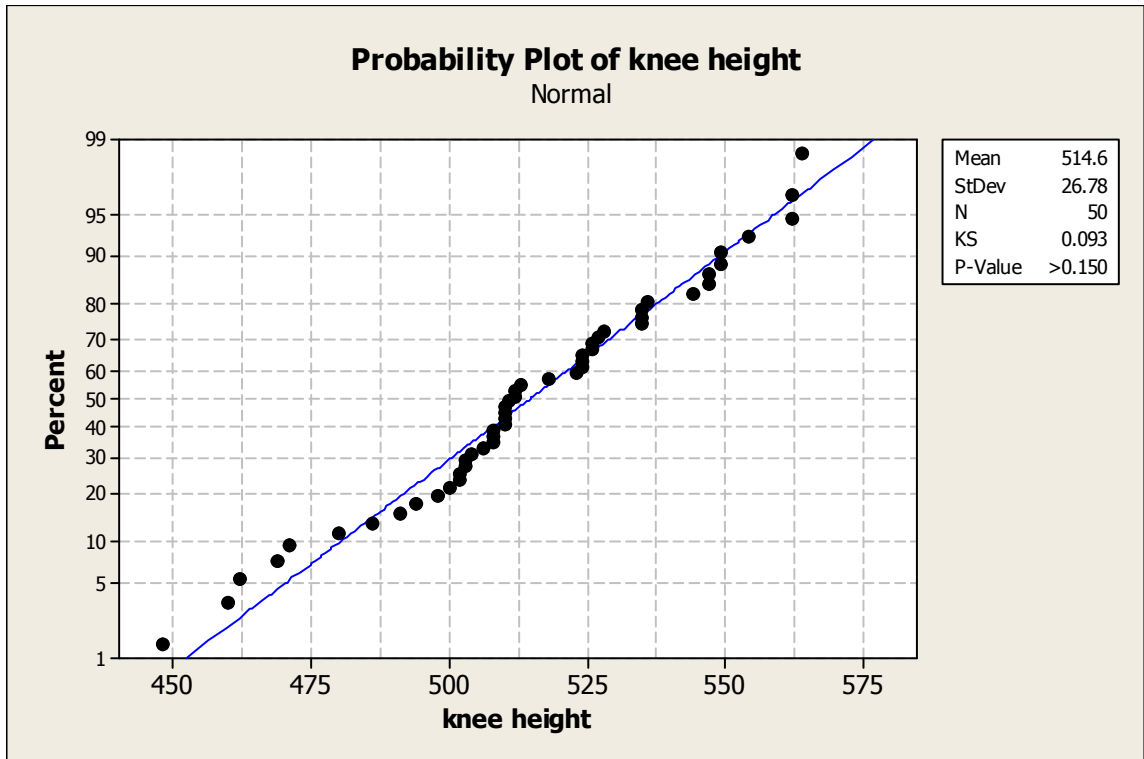

Figure C.21: Normal Probability Plot of Knee Height

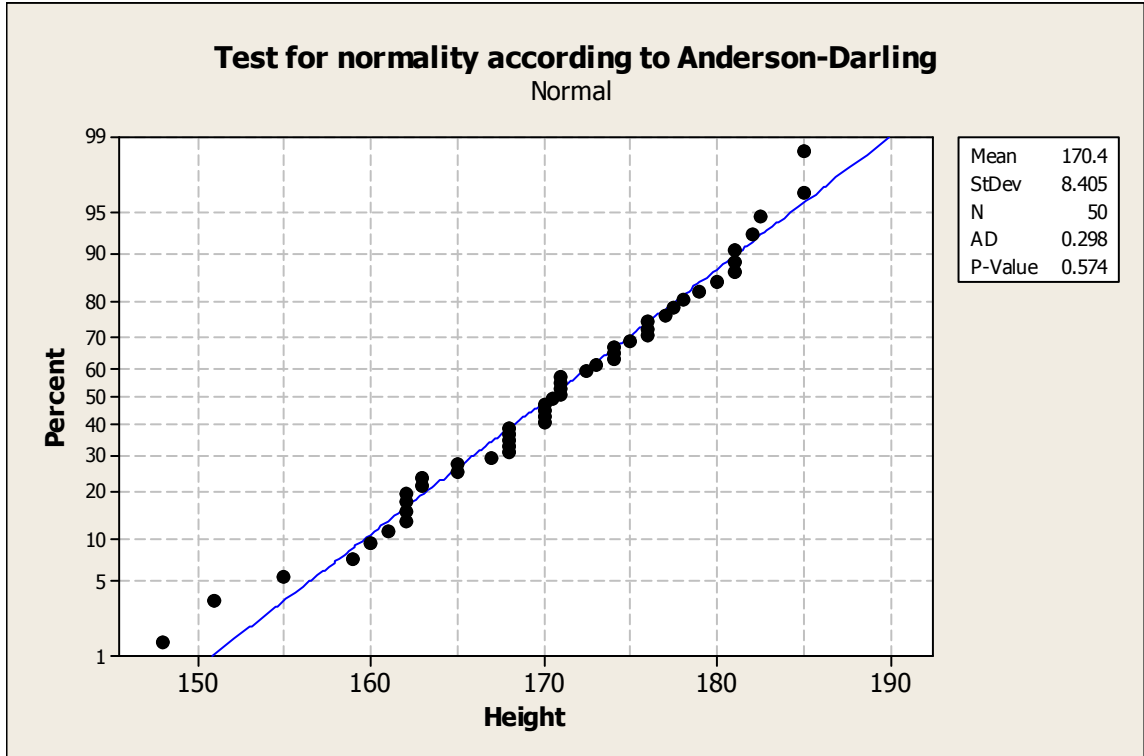

Figure C.22: Normal Probability Plot of Height

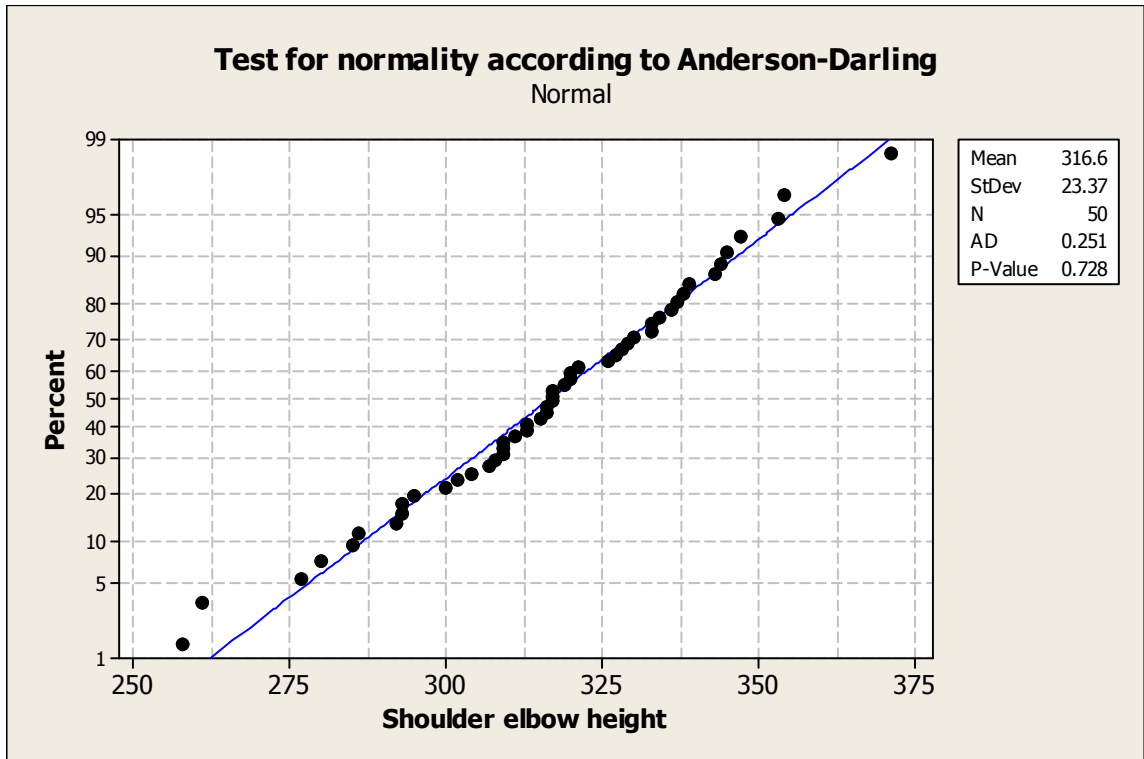

Figure C.23: Normal Probability Plot of Shoulder Elbow Height

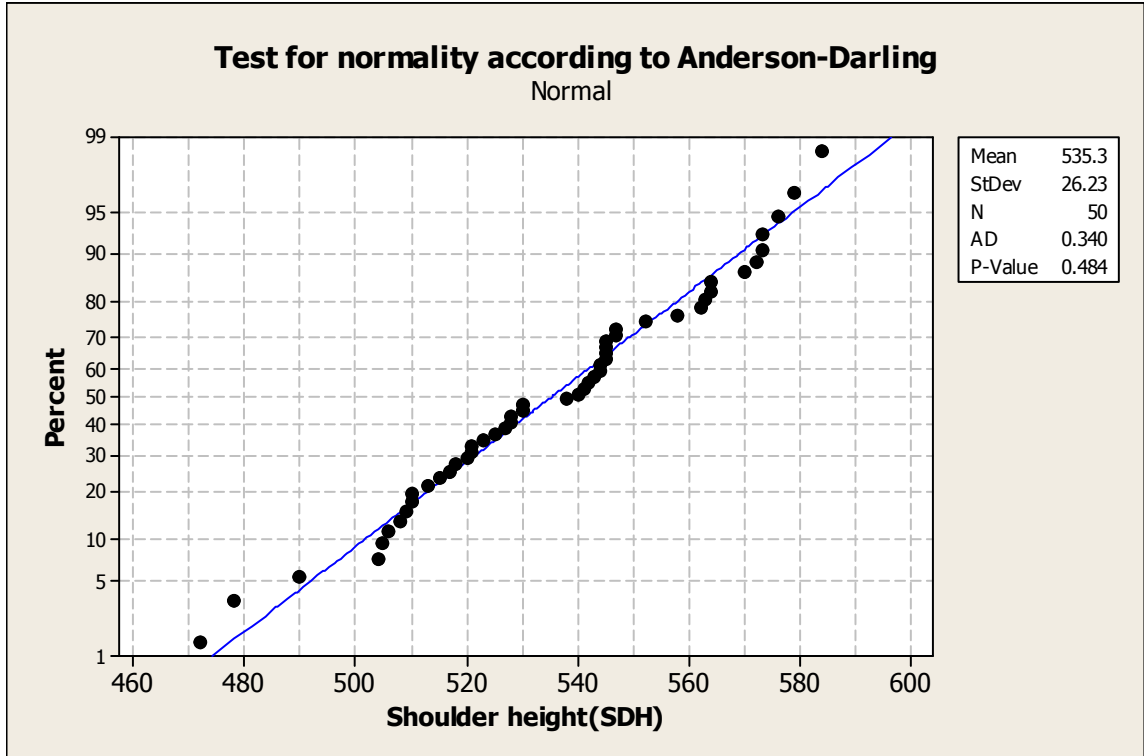

Figure C.24: Normal Probability Plot of Shoulder Height

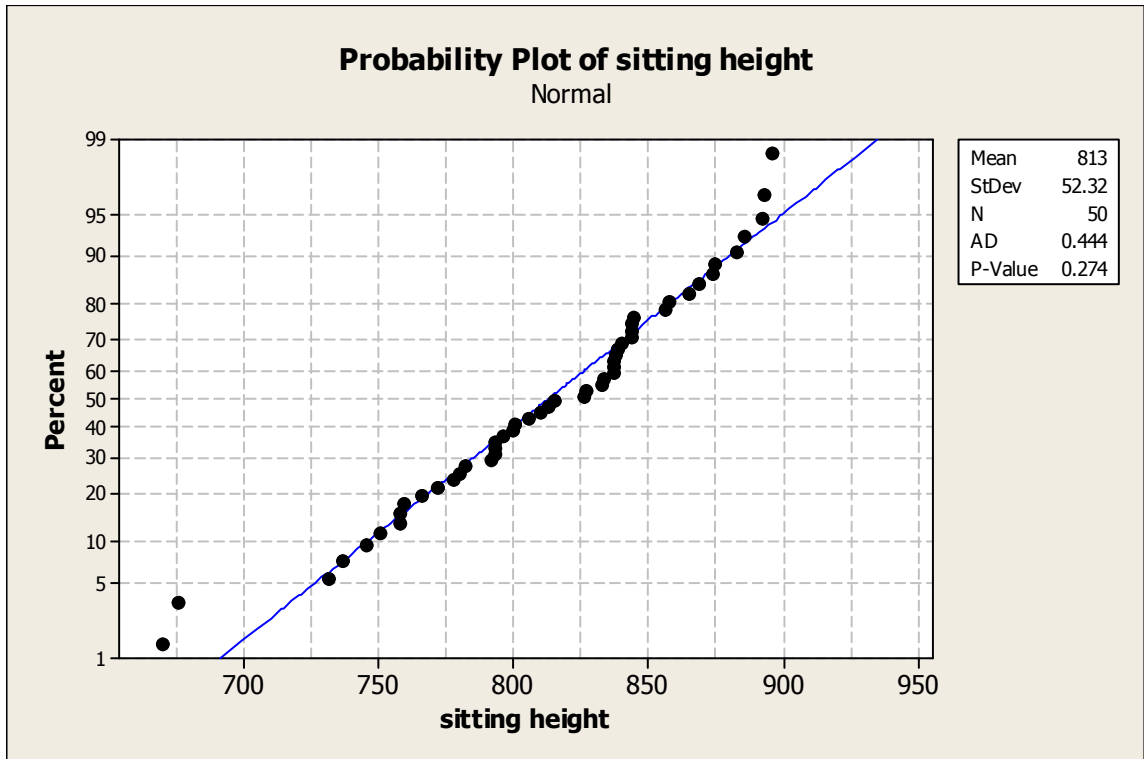

Figure C.25: Normal Probability Plot of Sitting Height

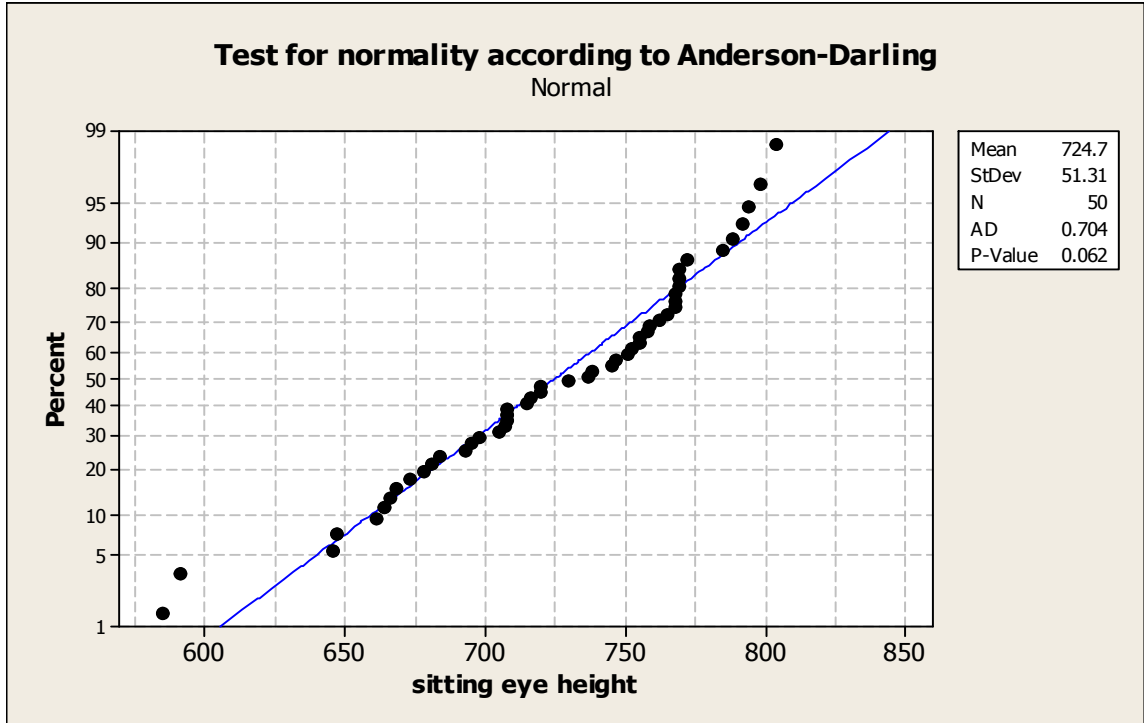

Figure C.26: Normal Probability Plot of Sitting Eye Height