

# **Analysis of a Propagation Model for Molecular Communication in Nanonetworks**

**Zahit Korkmaz**

Submitted to the  
Institute of Graduate Studies and Research  
in partial fulfillment of the requirements for the Degree of

Master of Science  
in  
Computer Engineering

Eastern Mediterranean University  
June 2014  
Gazimağusa, North Cyprus

Approval of the Institute of Graduate Studies and Research

---

Prof. Dr. Elvan Yılmaz  
Director

I certify that this thesis satisfies the requirements as a thesis for the degree of Master of Science in Computer Engineering.

---

Prof. Dr. Işık Aybay  
Chair, Department of Computer Engineering

We certify that we have read this thesis and that in our opinion it is fully adequate in scope and quality as a thesis for the degree of Master of Science in Computer Engineering.

---

Assoc. Prof. Dr. Muhammed Salamah  
Supervisor

Examining Committee

---

1. Prof. Dr. Işık Aybay

2. Assoc. Prof. Dr. Doğu Arifler

3. Assoc. Prof. Dr. Muhammed Salamah

## **ABSTRACT**

Nano-communication is a new technological invention that is achieved by the use of nanomachines with nanoscale functional components, with extremely limited workspaces. It provides numerous new solutions in the fields of biomedical sciences, industry, and the military by enabling communication among nano-devices in a scale ranging from one to a hundred nanometers. Single nanomachines are able to collaborate with each other through communication and two primary methods for communication among the nano-devices are based on molecular communication or electromagnetic communication. The former uses molecules instead of electromagnetic waves and involves some important processes – encoding, transmission, propagation, reception, and decoding. One significant subject in molecular communication is to analyze how molecules propagate through a fluid medium. In this thesis; we propose a new analytical model for the propagation process of molecules based on the random walk mechanism by formulating the probability density of latency in blood and water. The proposed model takes into account crucial parameters such as the radius of the propagating molecules, viscosity, drift velocity, and the temperature of the fluid medium with respect to different shear rates and thereupon can be used as a general propagation model for nano-communication. The main aim of this thesis is to determine the probability density of latency for the propagating molecules in blood and water that show different viscosity values in different temperatures. Based on the simulation results, latency is highly affected by the distance between source and destination, temperature, shear rate, viscosity, and radius of the propagating molecules through the blood medium.

We also evaluate the probability density function (PDF) of latency for different temperatures with different nanomachine distances through the water medium.

**Keywords:** Molecular Communication, Propagation, Latency, Viscosity, Shear Rate

## ÖZ

Nano iletişim yeni bir teknoloji olup, nanometrik boyutlarda oldukça sınırlı çalışma alanları olan nanometrik cihazlar ile yapılır. Biyomedikal, endüstriyel ve askeri alanlarda nanocihazlar arasında yeni çözümler sağlayan bu teknoloji çok küçük parçacıklardan oluşur. Nano teknolojisi, bir ile yüz nanometre arasında değişen bir ölçekte nano cihazlar arasındaki iletişimi sağlar. Nano cihazları arasındaki iletişim için iki temel yöntem vardır: moleküler ve nano-elektromanyetik iletişim. Moleküler iletişimde elektromanyetik dalgalar yerine moleküller kullanılır. Moleküler iletişimdaki aşamalar sırasıyla kodlama, iletim, yayılım, kabul ve kod çözmedir. Moleküler haberleşmedeki en önemli konu sıvı ortam içerisindeki moleküllerin yayılım aşamasındaki analizidir. Bu tezde, rasgele yürüyüş mekanizmasına dayalı moleküllerin yayılma süreci için bir analitik model önerilmiştir. Amaç kan ortamı için gecikme süresinin olası yoğunluk fonksiyonunu formüle etmektir. Önerilen bu model, farklı kayma hızı oranlarıyla birlikte yayılım aşamasındaki moleküllerin yarıçapı, akışkanlıkları, sürüklenme hızı ve sıvı ortamın sıcaklığı gibi önemli parametreleri göz önünde bulundurarak, nano iletişim için genel bir yayılma modeli olarak kullanılabilir bir analiz yapmak. Bu tezin temel amacı, kan ve suyun farklı sıcaklık ve akışkanlık değerlerinde yayılım aşaması sırasındaki moleküllerin gecikme süresini hesaplamaktır. Kanın akışkanlığı kayma hızı oranı ile sıcaklığa bağlıdır. Elde edilen sonuçlara göre, kandaki gecikme süresi nano parçacıkların mesafesine, sıcaklık, kayma hızı oranı, akışkanlık ve yayılım aşamasındaki moleküllerin yarıçapına bağlı olarak etkileşim göstermişlerdir. Su ortamında ise gecikme süresi olasılık oranlarını farklı sıcaklık ve nano parçacık mesafelerine göre değerlendirdik.

**Anahtar Kelimeler:** Moleküler Haberleşme, Yayılım, Gecikme, Viskozite, Kayma  
Hızı Oranı

To Müjde

## ACKNOWLEDGMENT

First of all, I would like to thank my love to my dear Mjde, whose love is keeping me alive. I love her so much and I am so glad to have her love. That is the meaning of my life. As long as I live, I will always love her.

In addition, I would like to thank my dear family who devoted their love to support me through my education life. I love them all.

On the other hand, I would like to thank my dear supervisor, Assoc. Prof. Dr. Muhammed Salamah for his support and guidance during my master's thesis.

Furthermore, I would like to thank Assoc. Prof. Dr. Tuna Tugcu, Res. Asst. Mehmet Őkr Kuran, and Res. Asst. Hakan Birkan Yılmaz who are working in Computer Engineering at Boĝaziçi University. They helped me to achieve the results during my thesis.

Finally, I would like to thank my friends who are an assistant at Department of Computer Engineering; Cengiz Kandemir, Őzkan Őiĝdem, Nasser Lotfi, Shahin Mehdipour, and Kaveh Kamkar for their help during my thesis.



# TABLE OF CONTENTS

ABSTRACT.....	iii
ÖZ.....	v
DEDICATION.....	vii
ACKNOWLEDGMENT.....	viii
LIST OF TABLES.....	xi
LIST OF FIGURES.....	xii
LIST OF ABBREVIATIONS.....	xvi
1 INTRODUCTION.....	1
1.1 Nanotechnology.....	2
1.2 NanoNetworking.....	3
1.3 Problem Statement.....	3
2 MOLECULAR COMMUNICATION.....	5
2.1 Explanation of Nanomachines.....	5
2.2 The Architecture of the Nanomachines.....	6
2.3 Potential Applications of Nanonetworks.....	9
2.4 A New Communication Paradigm.....	10
2.5 Molecular Communication versus Normal Communication.....	10
2.6 Molecular Communication Architecture.....	11
2.7 Molecular Communication Processes.....	12
2.7.1 Encoding.....	12
2.7.2 Sending.....	12
2.7.3 Propagation.....	12
2.7.4 Decoding.....	13

2.8 Expected Characteristics of Molecular Communication.....	13
2.8.1 Slow Velocity, Limited Stage, Great Jitter, and High Loss Rate.....	13
2.8.2 Energy Performance, and Poor Heat Dissipation.....	13
2.8.3 Biocompatibility.....	14
3 METHODOLOGY.....	15
3.1 Related Work.....	15
3.2 Theoretical Modeling of the Propagation Process.....	17
3.3 Viscosity of Blood.....	21
3.4 Viscosity of Water.....	22
4 NUMERICAL RESULTS.....	24
4.1 The PDF of the Latency for Different Distances in a Blood Medium.....	24
4.2 The PDF of the Latency with Drift Velocity in a Blood Medium.....	27
4.3 The PDF of the Latency with Different Blood Shear Rates.....	28
4.4 The PDF of the Latency for Different Blood Shear Rates with Drift Velocity.....	33
4.5 Comparison of Different Blood Shear Rates.....	39
4.6 The PDF of the Latency in a Water Medium.....	44
5 CONCLUSION.....	49
REFERENCES.....	51
APPENDICES.....	56
Appendix A: Water and Blood Viscosity Tables.....	57
Appendix B: Source Codes for Numerical Results.....	63

## LIST OF TABLES

Table 2.1: Molecular communication and telecommunication differences.....	11
Table 3.1: Vogel equation parameters.....	23

## LIST OF FIGURES

Figure 2.1: Different approaches for the development of nanomachines.....	6
Figure 2.2: Architecture mapping between a nanomachine and a cell.....	8
Figure 2.3: General structure of molecular communication.....	11
Figure 4.1: The PDF of the latency in a semi-infinite interval $(-\infty, d)$ for different nanomachine distances $d=\{1,2,4,8\}$ ( $\mu\text{m}$ ) and $D=0.1$ ( $\mu\text{m}^2/\text{s}$ ).....	26
Figure 4.2: The PDF of the latency for different velocity $v=\{0,0.1,0.2,0.4\}$ ( $\mu\text{m}/\text{s}$ ). $D=0.1$ ( $\mu\text{m}^2/\text{s}$ ) and $d=4$ ( $\mu\text{m}$ ).....	27
Figure 4.3: The PDF of the latency for blood viscosity at shear rate $1\text{s}^{-1}$ , $\eta=7.1\times 10^{-2}$ ( $\frac{\text{kg}}{\text{s}\cdot\text{m}}$ ), and $T=277$ (K) in $S_{pm} = S_{fluid}$ .....	28
Figure 4.4: The PDF of the latency for blood viscosity at shear rate $1\text{s}^{-1}$ , $\eta=3.65\times 10^{-2}$ ( $\frac{\text{kg}}{\text{s}\cdot\text{m}}$ ), and $T=310$ (K) in $S_{pm} = S_{fluid}$ .....	29
Figure 4.5: The PDF of the latency for blood viscosity at shear rate $1000\text{s}^{-1}$ , $\eta=0.583\times 10^{-2}$ ( $\frac{\text{kg}}{\text{s}\cdot\text{m}}$ ), and $T=277$ (K) in $S_{pm} = S_{fluid}$ .....	29
Figure 4.6: The PDF of the latency for blood viscosity at shear rate $1000\text{s}^{-1}$ , $\eta=0.31\times 10^{-2}$ ( $\frac{\text{kg}}{\text{s}\cdot\text{m}}$ ), and $T=310$ (K) in $S_{pm} = S_{fluid}$ .....	30
Figure 4.7: The PDF of the latency for blood viscosity at shear rate $1\text{s}^{-1}$ , $\eta=7.1\times 10^{-2}$ ( $\frac{\text{kg}}{\text{s}\cdot\text{m}}$ ), and $T=277$ (K) in $S_{pm} > S_{fluid}$ .....	31
Figure 4.8: The PDF of the latency for blood viscosity at shear rate $1\text{s}^{-1}$ , $\eta=3.65\times 10^{-2}$ ( $\frac{\text{kg}}{\text{s}\cdot\text{m}}$ ), and $T=310$ (K) in $S_{pm} > S_{fluid}$ .....	31
Figure 4.9: The PDF of the latency for blood viscosity at shear rate $1000\text{s}^{-1}$ , $\eta=0.583\times 10^{-2}$ ( $\frac{\text{kg}}{\text{s}\cdot\text{m}}$ ), and $T=277$ (K) in $S_{pm} > S_{fluid}$ .....	32

Figure 4.10: The PDF of the latency for blood viscosity at shear rate $1000s^{-1}$ , $\eta=0.31 \times 10^{-2}$ ( $\frac{kg}{s \cdot m}$ ), and $T=310(K)$ in $S_{pm} > S_{fluid}$ .....	32
Figure 4.11: The PDF of the latency in a blood medium for different velocity $v=(0,0.1,0.2,0.4)(\mu m/s)$ and $d=4(\mu m)$ in $S_{pm} = S_{fluid}$ , $T=277(K)$ at shear rate $1s^{-1}$ .....	34
Figure 4.12: The PDF of the latency in a blood medium for different velocity $v=(0,0.1,0.2,0.4)(\mu m/s)$ and $d=4(\mu m)$ in $S_{pm} = S_{fluid}$ , $T=310(K)$ at shear rate $1s^{-1}$ .....	34
Figure 4.13: The PDF of the latency in a blood medium for different velocity $v=(0,0.1,0.2,0.4)(\mu m/s)$ and $d=4(\mu m)$ in $S_{pm} = S_{fluid}$ , $T=277(K)$ at shear rate $1000s^{-1}$ .....	35
Figure 4.14: The PDF of the latency in a blood medium for different velocity $v=(0,0.1,0.2,0.4)(\mu m/s)$ and $d=4(\mu m)$ in $S_{pm} = S_{fluid}$ , $T=310(K)$ at shear rate $1000s^{-1}$ .....	35
Figure 4.15: The PDF of the latency in a blood medium for different velocity $v=(0,0.1,0.2,0.4)(\mu m/s)$ and $d=4(\mu m)$ in $S_{pm} > S_{fluid}$ , $T=277(K)$ at shear rate $1s^{-1}$ .....	36
Figure 4.16: The PDF of the latency in a blood medium for different velocity $v=(0,0.1,0.2,0.4)(\mu m/s)$ and $d=4(\mu m)$ in $S_{pm} > S_{fluid}$ , $T=310(K)$ at shear rate $1s^{-1}$ .....	37
Figure 4.17: The PDF of the latency in a blood medium for different velocity $v=(0,0.1,0.2,0.4)(\mu m/s)$ and $d=4(\mu m)$ in $S_{pm} > S_{fluid}$ , $T=277(K)$ at shear rate $1000s^{-1}$ .....	37

Figure 4.18: The PDF of the latency in a blood medium for different velocity $v=(0,0.1,0.2,0.4)(\mu\text{m/s})$ and $d=4(\mu\text{m})$ in $S_{pm} > S_{fluid}$ , $T=310(\text{K})$ at shear rate $1000\text{s}^{-1}$ .....	38
Figure 4.19: The PDF of the latency for blood viscosity at different shear rates in $d=1(\mu\text{m})$ , and $T=277(\text{K})$ in $S_{pm} = S_{fluid}$ .....	39
Figure 4.20: The PDF of the latency for blood viscosity at different shear rates in $d=8(\mu\text{m})$ , and $T=277(\text{K})$ in $S_{pm} = S_{fluid}$ .....	40
Figure 4.21: The PDF of the latency for blood viscosity at different shear rates in $d=1(\mu\text{m})$ , and $T=310(\text{K})$ in $S_{pm} = S_{fluid}$ .....	40
Figure 4.22: The PDF of the latency for blood viscosity at different shear rates in $d=8(\mu\text{m})$ , and $T=310(\text{K})$ in $S_{pm} = S_{fluid}$ .....	41
Figure 4.23: The PDF of the latency for blood viscosity at different shear rates in $d=1(\mu\text{m})$ , and $T=277(\text{K})$ in $S_{pm} > S_{fluid}$ .....	42
Figure 4.24: The PDF of the latency for blood viscosity at different shear rates in $d=8(\mu\text{m})$ , and $T=277(\text{K})$ in $S_{pm} > S_{fluid}$ .....	42
Figure 4.25: The PDF of the latency for blood viscosity at different shear rates in $d=1(\mu\text{m})$ , and $T=310(\text{K})$ in $S_{pm} > S_{fluid}$ .....	43
Figure 4.26: The PDF of the latency for blood viscosity at different shear rates in $d=8(\mu\text{m})$ , and $T=310(\text{K})$ in $S_{pm} > S_{fluid}$ .....	43
Figure 4.27: The PDF of the latency for water at $T=273(\text{K})$ and $\eta=0.001742$ in $S_{pm} > S_{fluid}$ .....	45
Figure 4.28: The PDF of the latency for water at $T=373(\text{K})$ and $\eta=0.0002836$ in $S_{pm} > S_{fluid}$ .....	45

Figure 4.29: The PDF of the latency for water at  $T=273(K)$  for different velocity  $v=\{0,0.1,0.2,0.4\}(\mu\text{m/s})$  and  $d=1(\mu\text{m})$  in  $S_{pm} > S_{fluid}$ .....46

Figure 4.30: The PDF of the latency for water in different temperatures in  $S_{pm} > S_{fluid}$  and  $d=1(\mu\text{m})$ .....47

Figure 4.31: The PDF of the latency for water in different temperatures in  $S_{pm} > S_{fluid}$  and  $d=8(\mu\text{m})$ .....48

## **LIST OF ABBREVIATIONS**

PDF                      Probability Density Function



# Chapter 1

## INTRODUCTION

Nano-communication is a new technology which provides numerous solutions in the fields of biomedicine, industry, military, and the environment. It envisages new systems to the science of engineering as well. Nano-communication is achieved by nanomachines, or the nanites. These are mechanical or electromechanical devices communicating with each other within a network. They comprise chemical sensors, nano-valves, and nano-switches [1]. These functional devices are made up of micro sized components and their workspaces are very limited. Biological nanomachines, however, can communicate over large areas ranging from meters to kilometers [4]. Examples of biological nanomachines are molecular motors, calcium signaling, and pheromones [1, 4]. In the field of biomedicine, drug delivery systems and health monitoring are achieved by biological nanomachines. In industry, food and water quality control systems are also done by nanomachines. As for the environmental sciences, nanomachines are utilized to measure air pollution. There are four communication types of nanomachines. The first type is nanomechanical communication. Nonomechanical phenomena play a fundamental role in a number of nanosciences or nanotechnological applications. Here communication is attained by nanomachines over mechanical contact. The second type of communication is electromagnetic communication. Electromagnetic communication enables nanomachines to communicate over electromagnetic waves. The third communication type is acoustic communication. In acoustic communication,

nanomachines are used to communicate with acoustic energy. The last communication type is molecular communication. In molecular communication, nanomachines use molecules to communicate with each other. Molecular type of communication plays a crucial role in nanonetworks. It is a relatively new paradigm and is based on biological systems [1], [4]. In molecular communication, there are three primary functional processes known as emission process, propagation process, and reception process respectively. In this thesis, the main concentration is on the analysis of the propagation models under different viscosity conditions.

## **1.1 Nanotechnology**

The main concept of the nanoscience and nanotechnology started with a speech entitled “There’s Plenty of Room at the Bottom” by physicist Richard Feynman in 1959 [1]. In his speech, Feynman defined a process in which scientists can control the individual molecules. The meaning of nanotechnology is to have functional systems for engineering at molecular or nanometer scale. Nanotechnology is important to manufacture small electronic devices at nanometer scale and a size limitation of nanotechnology is from 0.1 to 100 nanometers. Nanotechnology provides new solutions in creating new features and functions. Also, it offers new applications in many areas of technology such as medical and environmental applications. Nanotechnology products are important to construct complex devices such as nano-robots and nano-sensors. Manufacturing nano-materials is the future impact of nanotechnology because of tiny size, light weight, and strong. Integration of nanotechnology with current technology is also important for the future of manufacturing nano-devices at nanometer scale. In addition, building nanomanufacturing standards are also important to achieve effective products at nanometer scale.

## **1.2 NanoNetworking**

Nanonetworking is the study of communication among nano-devices at nano-scale. Nanonetworking provides new solutions for different applications in medical, industrial, environmental, and military fields. Nanonetworking is based on the interconnection of several nanomachines. The most important approach for nanonetworking is molecular communication to share information among nanomachines which is developed by the Bio-inspired approach [1]. Bio-inspired approach allows communicating among nanomachines by using molecules and it is based on biological systems found in nature.

## **1.3 Problem Statement**

According to [3], there are two types of nanocommunication among nano-devices: molecular communication and nano-electromagnetic communication. It also explains the propagation model for both types. Nano-electromagnetic communication uses electromagnetic waves for communicating. Molecular communication, on the other hand, uses molecules instead of electromagnetic waves. The latter also depends on the biological systems. There are five important processes in molecular communication which are encoding, sending, propagation, receiving, and decoding.

In this thesis, the propagation process will be analyzed under different viscosity conditions. In our opinion, the most important approach for propagation process is to analyze how molecules move through a fluid medium. The proposed model is formulating the probability density function of the latency in blood and water which is based on the radius of the propagating molecules, temperature, viscosity, distance among nanomachines, and drift velocity of the fluid medium with different shear rates.

The rest of the thesis is organized in following manner: Chapter 2 explores molecular communication paradigm. Chapter 3 reviews current literature on molecular communication and addresses methodology used. Chapter 4 provides numerical results and finally, Chapter 5 concludes this thesis by interpreting numerical results and discussing future work.

## Chapter 2

# MOLECULAR COMMUNICATION

### 2.1 Explanation of Nanomachines

Nanomachines are the result of a newly emerging technology. With components close to the scale of a nanometer they provide the range at nano-scale. Individual nanomachines can perform only simple tasks and they have been in the biological systems. Three different approaches exist for the improvement of nanomachines as seen in Figure 1.1. They are known as top-down, bottom-up, and bio-hybrid [1].

*Top-down approach:* The main aim of this approach is to improve nanoscale components by downscaling. The Nano-electromechanical system is the most important example (NEMS) [8] [9].

*Bottom-up approach:* The main aim for this approach is to improve nanomachines utilizing molecular manufacturing technology, nonetheless, this technology does not exist yet [10].

*Bio-hybrid approach:* Here the nanomachines can be found in biological systems as living organisms, like in many cells [11] [12].

In Figure 2.1, different nanomachine systems, based on their origin, natural or manmade, are seen. It further explains the range of natural and man-made nanomachines.

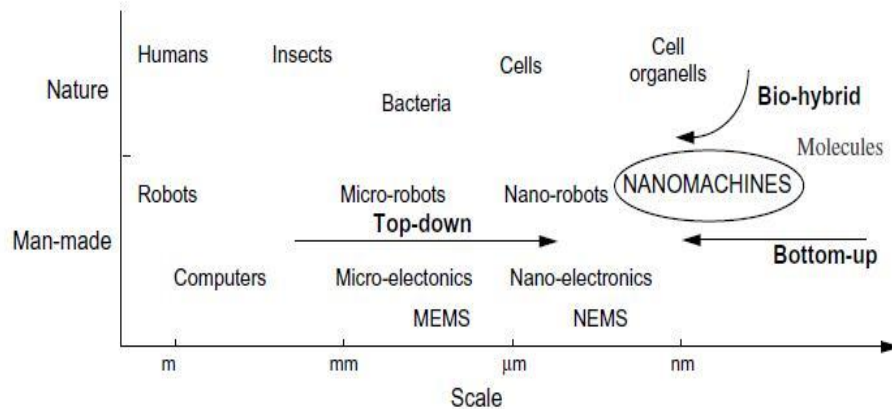

Figure 2.1: Different approaches for the development of nanomachines [1]

## 2.2 The Architecture of the Nanomachines

There are five important components for the nanomachine architecture [1].

- *Control Unit:* The main approach of this system is the control part of the nanomachine.
- *Communication unit:* The main approach of this system is to have a nanomachine in order to communicate with each other, the sender and the receiver, within a molecules unit.
- *Reproduction unit:* The main approach of this system is to reproduce all parts of the nanomachine.
- *Power Unit:* The main approach of this system is to supply power for nanomachine. The two main examples are the mitochondrion and the chloroplast.

- *Sensors and Actuators:* These devices are very important to act as an interface inbetween the nanomachines and the environment, such as temperature sensors or chemical sensors.

The current technology, however, is not enough to build such nanomachines but there are some biological systems that exist in nature with such nano-scale capabilities. The following units listed below are the components of architecture of biological nanomachines [1]:

- *Control Unit:* There is an important component in the cell which is nucleus and it is responsible for controlling the cell.
- *Communication unit:* In this unit, there are biological components communicating with each other such as gap junctions and pheromones' receptors.
- *Reproduction unit:* Here, there are many nanomachines such as the molecular motors.
- *Power Unit:* There are two main examples for this unit known as the mitochondrion and the chloroplast.
- *Sensors and Actuators:* There are many sensors and actuators in this unit such as the plant chloroplast or the bacteria flagellum.

The following figure explains the relationship between a nanomachine and a cell.

Microrobot node

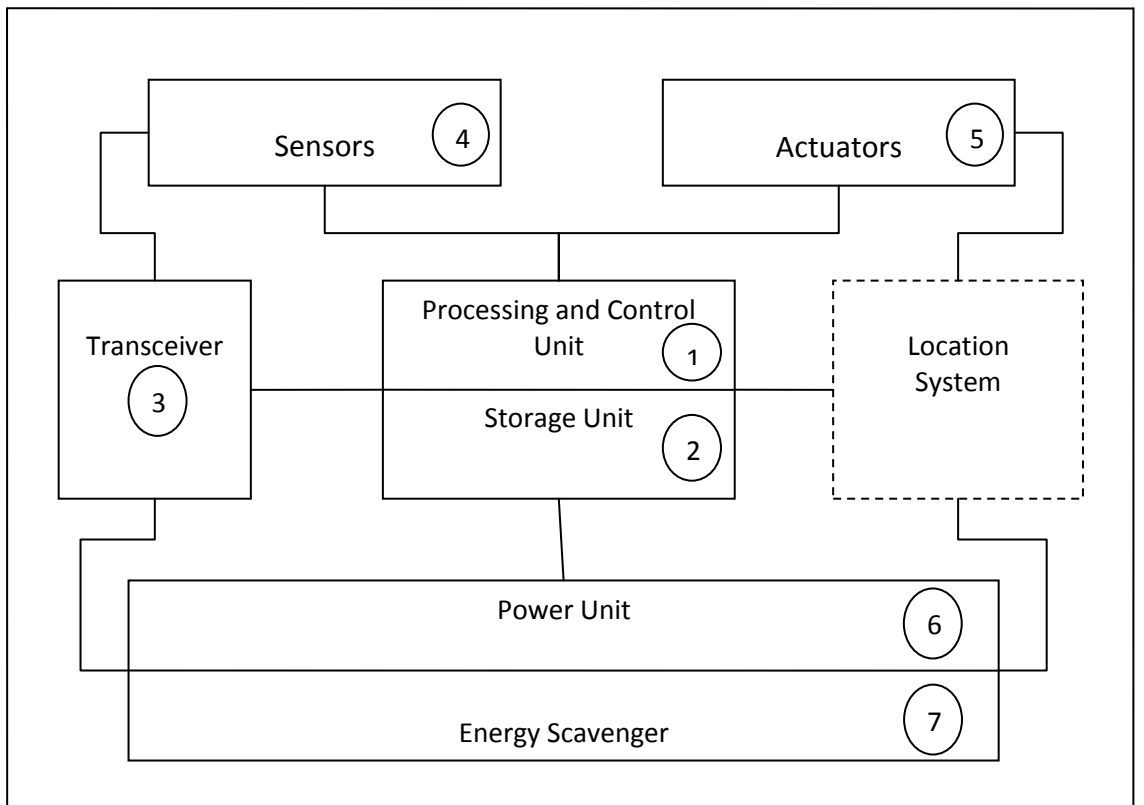

Nanonetwork node (Cell inspired)

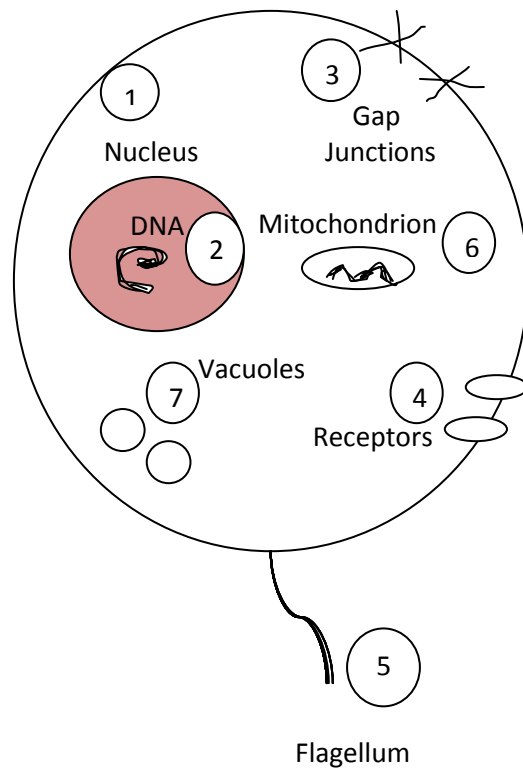

Figure 2.2: Architecture mapping between a nanomachine and a cell [1]



## 2.3 Potential Applications of Nanonetworks

There are four main types of applications of nanonetworks all of which are very important for the future of the nanonetworks to be used in different ways in different areas [1].

- *Biomedical Applications*

The most important applications are in the field of biomedicine. They are sure to have a huge impact on health issues as in cancer patients. A number of their applications are namely the immune system support, biohybrid implants, drug delivery systems, health monitoring, and genetic engineering.

- *Industrial and Consumer Good Applications*

Nanonetworks can be used to produce new products and this is very important for the future of the booming industry. These applications are namely used in food and water quality control, and to functionalize materials.

- *Military Applications*

Nanonetworks are also useful in military and are very important for the future of the martial defense systems. Military applications vary in their area of use, for example, nuclear, biological and chemical (NBC) defenses. Another example is the nano-functionalized equipments.

- *Environmental Applications*

Environment contains many biological systems and nanonetworks exist in these biological systems, therefore, they are equally important for the environment. Some

notable examples in this field are the biodegradation, animal and biodiversity control, and air pollution control.

## **2.4 A New Communication Paradigm**

Molecular communication is a new mechanism for the communication systems and it is based on the biological systems [4]. It is an important mechanism to provide new solutions for the biological components. The main idea of molecular communication is to have biological components in a fluid medium, in other words, there is a sender and a receiver in the fluid medium and the most important thing is to use molecules to enable communication in between these two bio-nanomachines.

## **2.5 Molecular Communication versus Normal Communication**

Molecular communication exhibits unique features that make it distinct from normal communication. Molecular communication is a nano-scale communication between nanomachines. This form of communication has differences from the traditional communication networks. First of all, molecular communication uses molecules to encode and decode information; while in traditional networks, electromagnetic waves are used to encode and or decode information. Secondly, in traditional networks, media type is via space or cables; however, in molecular communication, the media type is aqueous. In traditional networks, information type can be a text, an audio or a video but in molecular communication, there are chemical reactions and states from the biological systems, such as, molecular motors and pheromones. Below some important features of molecular communication versus traditional communication are discussed (Table 2.1) [4].

Table 2.1: Molecular communication and telecommunication differences [4]

	Telecommunication	Molecular communication
Information carrier	Electromagnetic waves, electrical/optical signals	Chemical signals
Media	Space, cables	Aqueous
Speed	Speed of light ( $3 \times 10^8$ m/s)	Extremely slow (nm~ $\mu$ m/s)
Range	Long distance (~km)	Short distance (nm~m)
Information	Texts, audio, videos	Chemical reactions, states
Other features	Reliable, high energy consumption	Unreliable, biocompatible energy efficient

## 2.6 Molecular Communication Architecture

Molecular communication is a new communication paradigm and it is based on the biological systems [4].

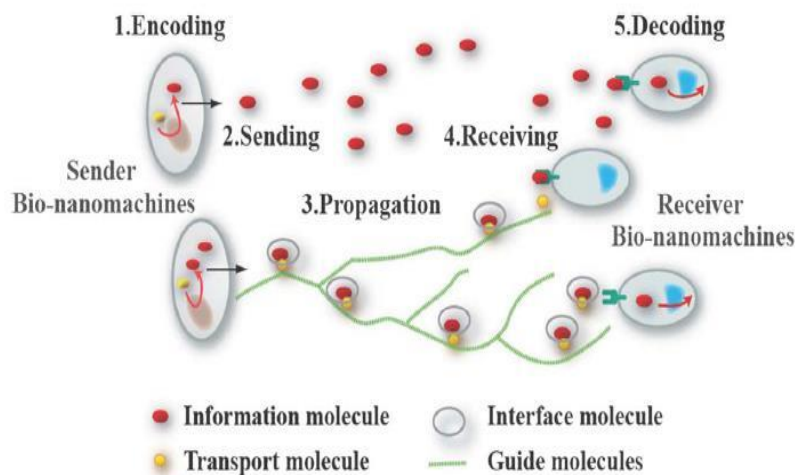

Figure 2.3: General structure of molecular communication [16]

Figure 2.3 illustrates the general architecture of molecular communication. It is based on biological systems and comprises the presence of different types of molecules in the medium: the information or the transport molecules. Information is denoted by information molecules [13] such as, calcium ions. There are two types of nanomachines in the medium: the sender and the receiver bio-nanomachines. Information molecules are released by the sender nanomachines and are detected by

the receiver nanomachines; the propagation path is from the sender nano device to the receiver nano device [2, 14]. There are also transport molecules, known as the molecular motors, in the medium. They carry the information molecule from the sender nanomachine to the receiver nanomachine [4, 15].

## **2.7 Molecular Communication Processes**

In molecular communication a mechanism helps a nanomachine to encode or decode information into molecules and to send it to another nanomachine. In this architecture, there are five main processes: encoding, sending, propagation, receiving, and decoding [5].

### **2.7.1 Encoding**

The encoding process is the first step of the molecular communication. The sender nano device encodes the data onto the propagating molecule; this information, however, has to be detectable for the receiver nano device [2, 4]. In other words, the information is concentrated on the information molecule or other specialized molecules are used to encode information onto the information molecule, such as the protein molecules or the DNA molecules.

### **2.7.2 Sending**

Sending process is the second step in molecular communication. In this process, information molecules are released into the fluid by the sender bio-nanomachine. It is based on biological systems known as the gap junction channels; information molecules diffuse by opening channels in the fluid medium. Another important thing is to have chemical reactions on the sender bio-nanomachine side.

### **2.7.3 Propagation**

Propagation process starts with the release of information molecules into the fluid medium by the sender bio-nanomachine hence making propagating molecules move

from the sender nano device to the receiver nano device. Propagation of information molecules is possible in two ways: passive or active transport. It is utterly important to protect information molecules, during the propagation process, from the noise in the fluid medium.

#### **2.7.4 Decoding**

Decoding process is the final step of the molecular communication. It takes place in the form of chemical reactions on the side of the receiver bio-nanomachine. After the propagating process, information molecules are detected by the receiver bio-nanomachines and new molecules are generated as a result of chemical reactions. Alternately, information molecules can be decoded by the gap junction channels in the fluid medium.

### **2.8 Expected Characteristics of Molecular Communication**

Based on the biological systems, some important characteristics of molecular communication are observed in the fluid medium [2, 4].

#### **2.8.1 Slow Velocity, Limited Stage, Great Jitter, and High Loss Rate**

Molecular communication presents some expected characteristics in the fluid medium: the velocity of the molecular communication slows down and its range becomes very small based on the biological components. Because of the large latency of the propagating, and the high loss rate due to the unpredictability of the molecules during propagation process, it has a large jitter. In molecular communication, diffusion process is modeled by the Brownian motion and the range of this model is very limited [2].

#### **2.8.2 Energy Performance, and Poor Heat Dissipation**

Molecular communication is based on the biological systems and it uses molecules. In molecular communication, chemical reactions mimics power supplies for the

molecules in the fluid medium and provide efficient amount of power for them. They improve poor heat dissipation during the molecular communication processes as in the myosin molecular motors [2].

### **2.8.3 Biocompatibility**

It is the ability to perform well with an appropriate host in a specific situation. Molecular communication utilizes biological systems and bio-nanomachines communicate as chemical reactions. Sender and receiver nanomachines communicate via the natural fragments in the biological systems. Biocompatibility can be improved by some medical applications thus making it possible to place bio-nanomachines in the biological systems for molecular communication as in the treatment of cancer.

## Chapter 3

### METHODOLOGY

#### 3.1 Related Work

In molecular communication, molecules are propagated via diffusion [18]. The diffusion process is explained by Fick's equations [17]. Propagated molecules are messenger molecules and they enable molecular communication. In the propagation process, propagation medium is a fluid medium and the path of propagation is from sender bio-nanomachine to receiver bio-nanomachine [2]. The propagation of messenger molecules is random, that is to say, in all directions in the fluid medium. These random movements of propagating molecules are modeled by the Brownian motion. An important example of the random movement of the molecules in the fluid medium is the random walk [2]. Random walk is a very popular model for molecular communication.

In [2], random walk is discussed, in molecular communication, for theoretical modeling. Random walk model is based on biophysics that includes different kinds of theoretical modeling. There are three different types of random walk models: pure random walk, random walk with drift, and random walk with reaction using amplifiers [2]. In [2], the probability density function (PDF) formula is used to find the average latency, jitter, and loss rate. Additionally, the PDF is taken by the Gaussian distribution. The probability mass function is also used for the same parameters. The term latency means that after the propagation process, propagating

molecules first hit the receiver nanomachine in the fluid medium. There is also a drift velocity for propagating molecules in the fluid medium.

In [19], a system model based on the Brownian motion is given, and it contains the propagation process. PDF with drift velocity is used for the location of the propagating molecules which is based on the Gaussian distribution. Besides, the PDF is used to find the absorption time of the propagating molecules.

In [20], the PDF is used to find the distance to the nearest nanomachine with residence time in a two-dimensional area. It is used to find time in different distances between the sender and the receiver nanomachines. The PDF, therefore, is based on the Gaussian distribution for molecular communication.

In [17], another type of PDF formula is observed. It depends on the diffusion coefficient; the distance and time between the sender and the receiver bio-nanomachines. Diffusion coefficient is based on the temperature and the viscosity of the fluid medium, and the radius of the propagating molecule.

The main concentration of this thesis is to change the diffusion coefficient parameters, such as, the temperature and the viscosity of the blood in different blood shear rates and also to see the numerical results with realistic parameters for bio-nanomachines molecules in molecular communication. When blood in different shear rates is applied as a fluid medium, what will be the latency for the propagating molecules? How can we compare the latency for different distances between the sender and the receiver bio-nanomachines in blood medium with different temperatures? There is another important aspect of this thesis and it is to add velocity



in blood medium. What will be the total latency with drift velocity for the propagating molecules and what is the difference between normal blood medium and blood with drift velocity medium for propagating molecules? Here we are going to address to these questions.

### 3.2 Theoretical Modeling of the Propagation Process

Theoretical models are developed in order to compare the quality of the molecular communication. Average latency or propagation delay is calculated by the theoretical models. There are three important propagation techniques in molecular communication: walkway-based, flow-based, and diffusion-based [3]. In walkway-based, there are pre-defined paths transmitting molecules to the communicating transmitter and receiver. As an example, the molecular motors can be shown [6]. In flow-based and diffusion-based techniques, molecules propagate over diffusion in a fluid medium [3, 7].

In molecular communication, the propagating molecules propagate randomly to all directions in the fluid medium. In our model, the propagating molecules propagate in a one-dimensional area in the fluid medium. We also have analyzed the latency of the molecular communication during the propagation process; the first hitting time to the receiver nanomachine of the propagating molecules in a one-dimensional interval. The following formula gives PDF for molecular communication considering the Gaussian distribution, [17]:

$$f(t) = \begin{cases} 0 & (t = 0) \\ \frac{1}{\sqrt{4\pi Dt}} \exp\left(-\frac{d^2}{4Dt}\right) & (t > 0). \end{cases} \quad (3.1)$$

where  $D$  is the diffusion coefficient of the propagating molecules during the propagation process and  $d$  is the distance between the sender nanomachine and the receiver nanomachine in a one dimensional interval  $(-\infty, d]$ . Diffusion coefficient represents the inclination of the propagating molecules during the propagation process through the fluid medium and it can be determined by the following formula [27]:

$$D = \frac{K_b \cdot T}{b} \quad (3.2)$$

where  $K_b$  is a fixed value called the Boltzmann constant,  $T$  is the temperature of the fluid medium, and  $b$  is also a fixed value representing the drag constant of the molecule in the fluid medium. In addition, there are two different ways to find drag constant value which depends on the size of the propagating molecule ( $S_{pm}$ ) and the size of the propagating molecules of the fluid medium ( $S_{fluid}$ ) [21] and the drag constant can be determined by the following formula [27]:

$$b = \begin{cases} 4\pi\eta r_m, & \text{if } S_{pm} \approx S_{fluid} \\ 6\pi\eta r_m, & \text{if } S_{pm} > S_{fluid} \end{cases} \quad (3.3)$$

$\eta$  represents the viscosity of the fluid medium and  $r_m$  is the radius of the propagating molecule in the fluid medium. In this thesis, our propagating molecule is the insulin molecule. The radius of the insulin molecule is 5-10 nm in diameter [22]. The main aim of choosing insulin molecule is to see the numerical results in the blood medium. It is used in the human blood in the medical areas. We can call it as a messenger molecule because the insulin molecule is in blood medium. In addition, when a fluid medium has a drift velocity in a one-dimensional interval  $(-\infty, d]$ , the PDF of the latency is given as [28] :

$$f(t)=\begin{cases} 0 & (t = 0) \\ \frac{1}{\sqrt{4\pi Dt}} \exp\left(-\frac{(d-vt)^2}{4Dt}\right) & (t > 0). \end{cases} \quad (3.4)$$

where  $v$  is the fluid velocity; it is greater or equal to zero.

The most important aspect of this thesis is to observe the viscosity symbol in the PDF. Therefore, we need to derive a new formula for the PDF of the latency with viscosity parameter. When the size of the propagating molecule is equal to the size of the molecules of the fluid medium, the following formulas are used:

$$a) \text{ if } S_{pm} \approx S_{fluid}$$

$$D = \frac{K_b \times T}{4\pi\eta r_m} \quad (3.5)$$

where  $D$  is the diffusion coefficient,  $K_b$  is the Boltzmann constant,  $T$  is the temperature,  $\eta$  is the viscosity of the fluid medium, and  $r_m$  is the radius of the propagating molecule in the fluid medium. After that, we can write the PDF of the latency for the given condition:

$$f(t)=\begin{cases} 0 & (t = 0) \\ \frac{1}{\sqrt{\frac{K_b \times T \times t}{\eta r_m}}} \exp\left(-\frac{d^2}{\frac{K_b \times T \times t}{\pi \eta r_m}}\right) & (t > 0). \end{cases} \quad (3.6)$$

All parameters are known from the previous formulas. In addition, when the size of the propagating molecules is bigger than the size of the molecules of the fluid medium, the PDF is given by:

b) if  $S_{pm} \gg S_{fluid}$

$$D = \frac{K_b \times T}{6\pi\eta r_m} \quad (3.7)$$

After that, we can write the PDF of the latency for the given condition:

$$f(t) = \begin{cases} 0 & (t = 0) \\ \frac{1}{\sqrt{\frac{(\frac{2}{3}) \times K_b \times T \times t}{\eta r_m}}} \exp\left(-\frac{d^2}{\frac{(\frac{2}{3}) \times K_b \times T \times t}{\pi \eta r_m}}\right) & (t > 0). \end{cases} \quad (3.8)$$

$$\text{Let } K_z = \begin{cases} \frac{K_b}{r_m} & \text{if } S_{pm} \approx S_{fluid} \\ \frac{(\frac{2}{3}) \cdot K_b}{r_m} & \text{if } S_{pm} > S_{fluid} \end{cases} \quad (3.9)$$

where  $K_z$  is a new constant value in this thesis meaning that there are two constant values in the PDF: Boltzmann constant and the radius of the insulin molecule. Therefore, we can easily create a new constant value and the unit of the new constant would be given in the previous formula. Moreover, the PDF can be calculated using the new constant given as:

$$f(t) = \begin{cases} 0 & (t = 0) \\ \frac{1}{\sqrt{\frac{K_z \times T \times t}{\eta}}} \exp\left(-\frac{d^2}{\frac{K_z \times T \times t}{\pi \eta}}\right) & (t > 0). \end{cases} \quad (3.10)$$

where  $K_z$  is a new constant, T is the temperature, and  $\eta$  is the viscosity of the fluid medium.

### 3.3 Viscosity of Blood

Blood contains plasma, red blood cells, and white blood cells. There are two important parameters to define the viscosity of blood: shear rate ( $\gamma$ ) and shear stress ( $\tau$ ). Shear rate is important in calculating the viscosity of the fluid medium. Shear rate can be calculated using the following formula [29]:

$$\gamma = \frac{v}{h} \quad (3.11)$$

where  $v$  is the constant velocity of the fluid medium and  $h$  is the distance between the two parallel flows of the fluid medium. Shear stress is another important factor in finding the viscosity of the blood. Shear stress can be calculated using the following formula [29]:

$$\tau = \frac{F}{A} \quad (3.12)$$

where  $F$  is the force applied vector and  $A$  is the cross section vector. As a result, the viscosity of the blood can calculate by the following formula [25]:

$$\eta = \frac{\tau}{\gamma} \quad (3.13)$$

where  $\tau$  is the shear stress and  $\gamma$  is the shear rate of the fluid medium.

Blood viscosity formulas are given for the clarification of this topic. Shear rate and shear stress are calculated by the capillary viscometer machine [25]. Blood viscosity is based on the hematocrit rate, temperature, erythrocyte deformability, plasma viscosity, and erythrocyte aggregation [24]. Moreover, a 1 °C of increase in human

body temperature results in 2% decrease in human blood viscosity [23]. The hematocrit rate approximately equals to 45+1% [26]. The viscosity of the blood is calculated by the pressure-scanning capillary viscometer using different shear rates at different temperatures [25]. We then use the viscosity values for different shear rates at human body temperature [26]. As a result, we calculate the value of the blood viscosity in different shear rates at different temperatures. According to [23,25,26], the blood viscosity tables represent different values of blood viscosity with different shear rates and these measured viscosity values have been used to define the probability density of the latency at different temperatures. The range of the taken blood temperature values are from 277 to 310 K. The highest blood temperature is taken as 310 K or 37°C which is same with human body temperature. The lowest blood temperature is taken as 277 K or 4°C because blood bank refrigerators can keep blood at temperatures between 1 to 6°C.

### **3.4 Viscosity of Water**

According to the Vogel equation [30], Vogel equation parameters are used to calculate the viscosity of water under different temperatures. The formula of the viscosity of water is given using the Vogel equation [30]:

$$\eta = e^{A + \frac{B}{C+T}} \quad (3.14)$$

where  $\eta$  is the water viscosity (mPa\*s), T is the temperature (Kelvin) of the water, A, B, and C are the Vogel equation parameters given using the following table [30]:

Table 3.1: Vogel equation parameters

A	B	C	Tmin[K]	Tmax[K]
-3.7188	578.919	-137.546	273	373

According to Table 3-1, the viscosity of water can be determined by these parameters in the given temperature interval. According to [30], the water viscosity table represents the viscosity of the water under different temperatures and the water viscosity unit is reproduced for our propagation model. The range of the taken water temperature values are from 273 to 373 K. The highest water temperature is taken as 373 K or 100°C and it is the boiling point of water. On the other hand, the lowest water temperature is taken as 273 K or 0°C and it is the freezing point of water. Our expectation is to observe the results between freezing and boiling points of water at different temperatures.

## Chapter 4

### NUMERICAL RESULTS

This chapter deals with the numerical results for the PDF of the latency for propagating molecules during the propagation process.

#### 4.1 The PDF of the Latency for Different Distances in a Blood

##### Medium

Let's assume that the sender nanomachine releases molecules at time  $t=0$  and the location of the sender nanomachine is at  $x=0$ . The receiver nanomachine is at  $x=d$  ( $d>0$ ) at a one-dimensional interval in a fluid medium which is the distance between a sender and a receiver nanomachines. The fluid medium has a semi-infinite interval  $(-\infty, d]$ . PDF is a function  $f$  defined on a semi-finite interval  $(-\infty, d]$  and it has the following properties.

$$f(t) \geq 0 \text{ for every } t \quad (4.1)$$

$$\int_{-\infty}^d f(t) dt = 1 \quad (4.2)$$

The probability of an individual molecule to hit the receiver nanomachine with latency ( $t$ ) is calculated with the following formula:

$$P([t, t+\Delta t) ) \approx f_t(t) \times \Delta t \quad \text{for } \Delta t \rightarrow 0 \quad (4.3)$$



where  $f_t(t)$  is the probability density of a propagating molecule at time  $t$  and  $\Delta t$  is the difference between two points in a given latency range. The theoretical average latency is given as:

$$\int_0^{\infty} t f(t) dt = \infty \quad (4.4)$$

The theoretical average latency of a propagating molecule to reach the receiver nanomachine at any location is infinity. This means that the receiver nanomachine is expected to wait for a long time to receive propagating molecule [2]. The probability density of the latency indicates the first hitting time to the receiver nanomachine for the propagating molecules during the propagation process. Taking these into consideration, we can say that the value of latency shows that these propagating molecules are delayed in reaching the receiver nanomachines during the propagation process. The propagating molecules propagate randomly after their time of release in the fluid medium. We can also find the propagation time of each propagating molecule at the time of release and when they first hit the fluid medium. Taking all these into account, we can say that the propagation time refers to the latency for each propagating molecule. The following figure represents the PDF of the latency for different distances in a fluid medium.

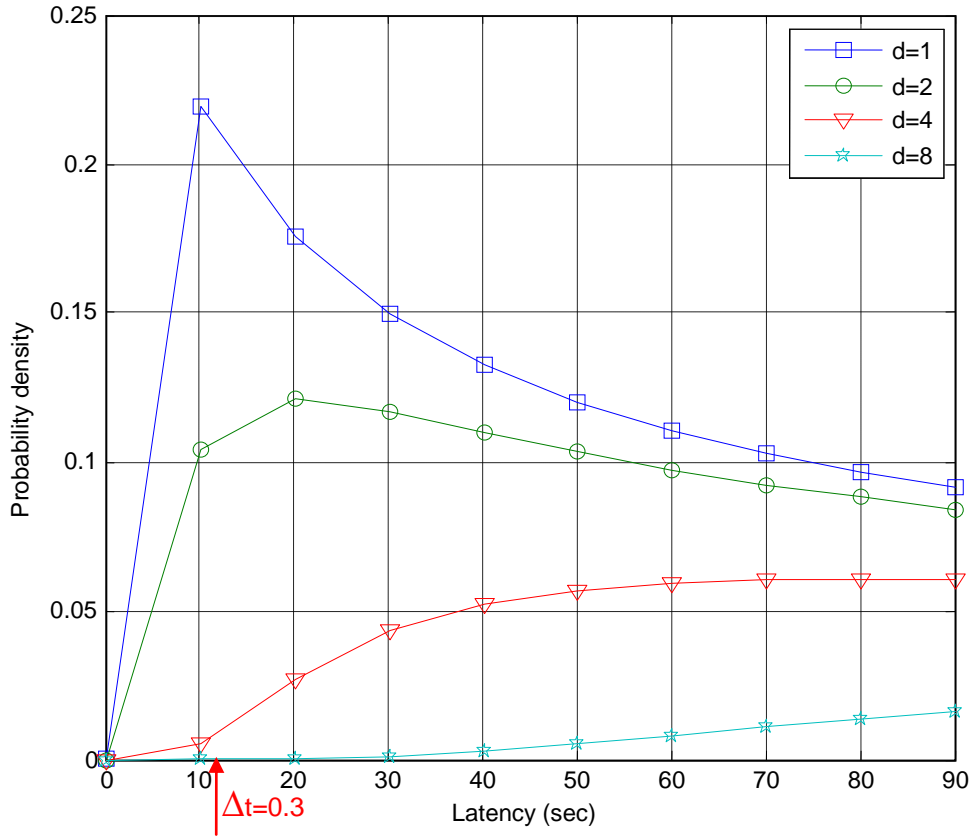

Figure 4.1: The PDF of the latency in a semi-unbounded interval  $(-\infty, d]$  for different nanomachine distances  $d=\{1,2,4,8\}$  ( $\mu\text{m}$ ) and  $D=0.1$  ( $\mu\text{m}^2/\text{s}$ ).

As seen in Figure 4.1, if we assume that  $\Delta t$  is 0.3, we can calculate the probability of an individual molecule to hit the receiver nanomachine with latency around 10 seconds by using 4.3. For example, the probability density of a propagating molecule is approximately equal to 0.22 when the distance ( $d$ ) between the sender and the receiver nanomachines is equal to 1 and  $t=10$ . Therefore the hit probability for a propagation molecule with latency around 10 seconds can be approximately calculated as:  $0.22 \times 0.3 \approx 0.066$ . Figure 4.1 shows that the distance of the propagating molecules strongly affects latency. When the distance between the sender and the receiver nanomachine increases, PDF decreases accordingly. In addition, after a period of time, the hit probability decreases and approaches to zero for  $t=\infty$ , because of the chemical reactions between the propagating molecules [1].

## 4.2 The PDF of the Latency with Drift Velocity in a Blood Medium

When a fluid medium has a drift velocity, propagating molecules are affected by the drift velocity during the propagation process. The following figure illustrates the PDF of latency for the same distance of drift velocity in a fluid medium.

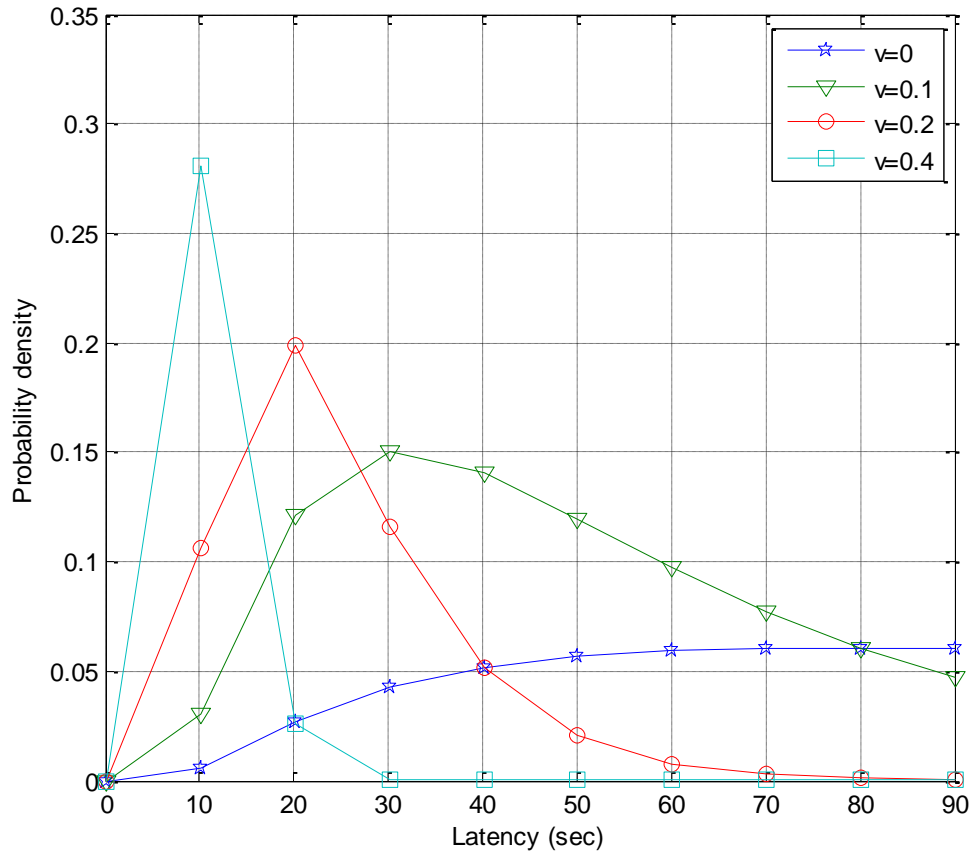

Figure 4.2: The PDF of the latency for different velocity  $v=\{0,0.1,0.2,0.4\}$  ( $\mu\text{m/s}$ ),  $D=0.1(\mu\text{m}^2/\text{s})$ , and  $d=4$  ( $\mu\text{m}$ ).

Figure 4.2: As the drift velocity of the fluid medium increases, the latency decreases for the propagating molecules. Similarly, the distance between the sender and the receiver nanomachines increases, the fluid medium then becomes more efficient for propagating molecules during the propagation process.

### 4.3 PDF of the Latency with Different Blood Shear Rates

In our scenario, we have some constant values in the PDF: The Boltzmann constant ( $K_z$ ) and the radius of the insulin molecule ( $r_m$ ). In our measurements,  $K_z$  is equal to  $1.3807 \times 10^{-23} \left(\frac{kg \cdot m^2}{s^2 \cdot K}\right)$  [22], and  $r_m$  is equal to  $2.5 \times 10^{-9}$  (m) [22]. Temperature (T) only reveals two different values in our calculations which are 277 and 310 (Kelvin). The blood viscosity values for different shear rates have also been defined in the previous section. Additionally, our results are calculated for the comparison of the size of the propagating molecule ( $S_{pm}$ ) and for the size of the molecule of the fluid medium ( $S_{fluid}$ ). There are two conditions for the propagating model: First, we evaluate the PDF of the latency according to the initial condition  $S_{pm} = S_{fluid}$ .

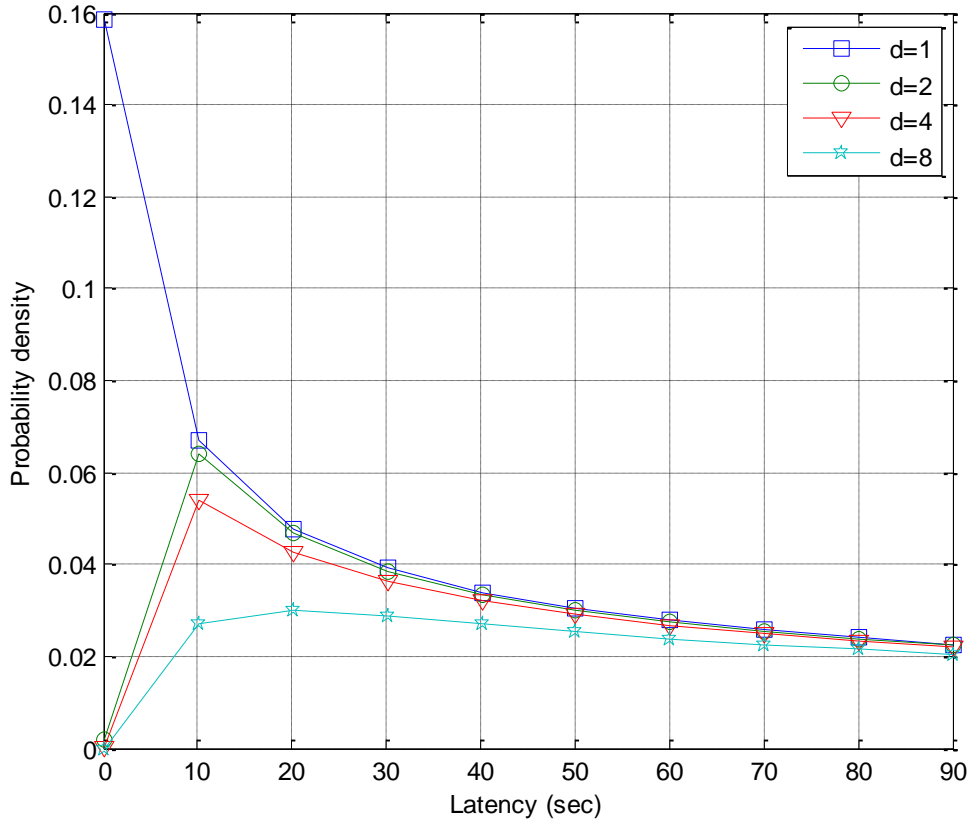

Figure 4.3: The PDF of the latency for blood viscosity at shear rate  $1s^{-1}$ ,  $\eta=7.1 \times 10^{-2} \left(\frac{kg}{s \cdot m}\right)$ , and  $T=277(K)$  in  $S_{pm} = S_{fluid}$ .

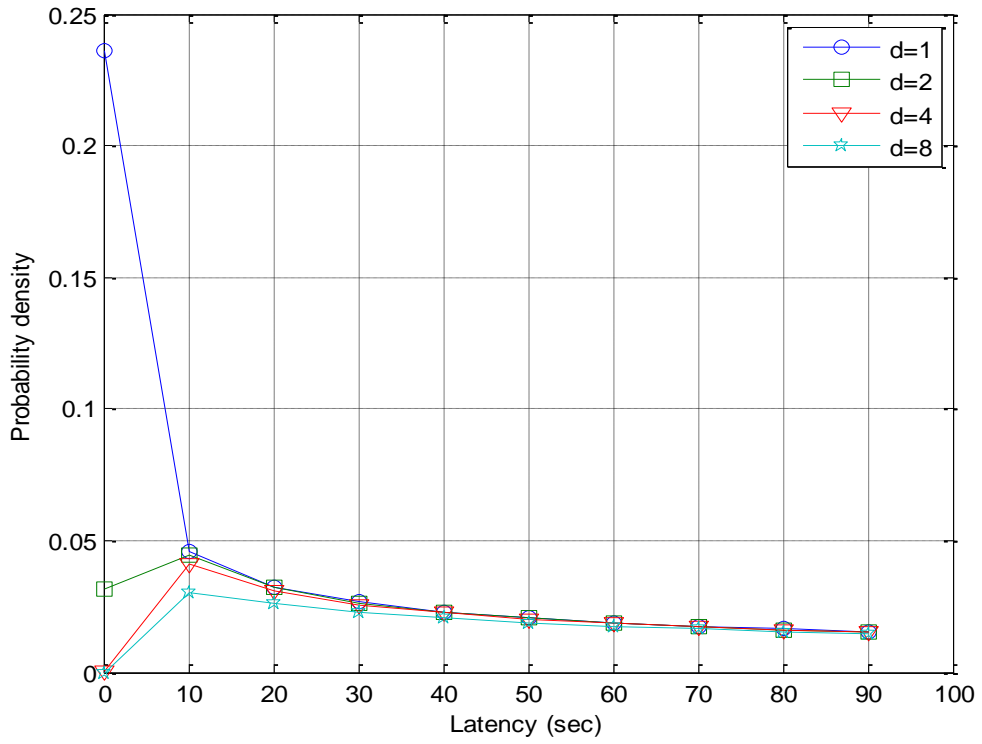

Figure 4.4: The PDF of the latency for blood viscosity at shear rate  $1s^{-1}$ ,  $\eta=3.65\times 10^{-2} (\frac{kg}{s\cdot m})$ , and  $T=310(K)$  in  $S_{pm} = S_{fluid}$ .

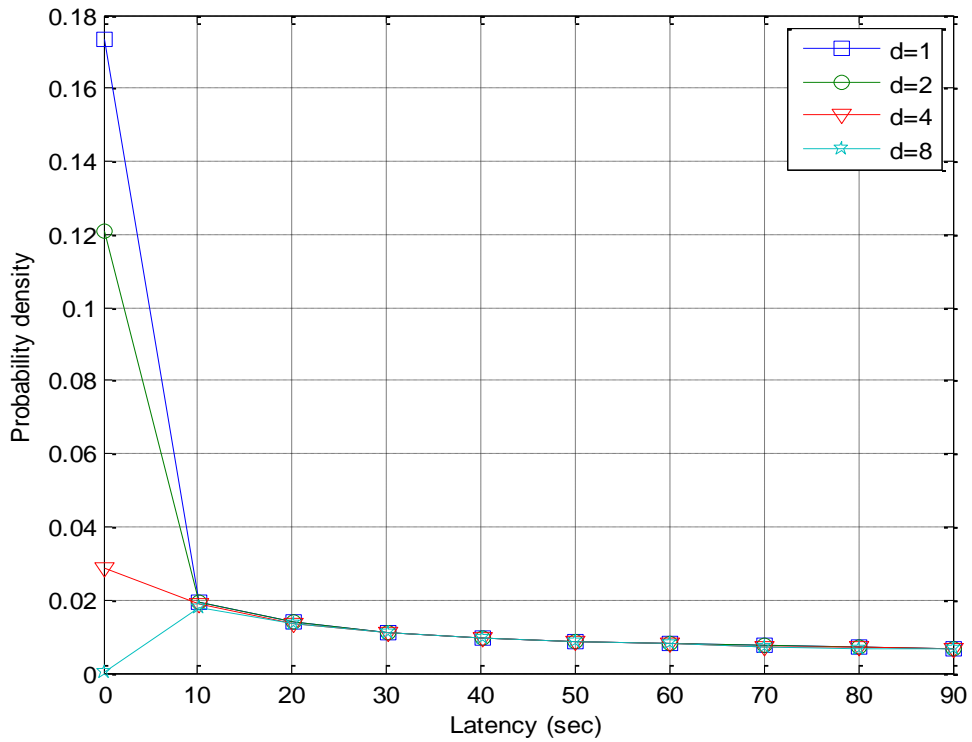

Figure 4.5: The PDF of the latency for blood viscosity at shear rate  $1000s^{-1}$ ,  $\eta=0.583\times 10^{-2} (\frac{kg}{s\cdot m})$ , and  $T=277(K)$  in  $S_{pm} = S_{fluid}$ .

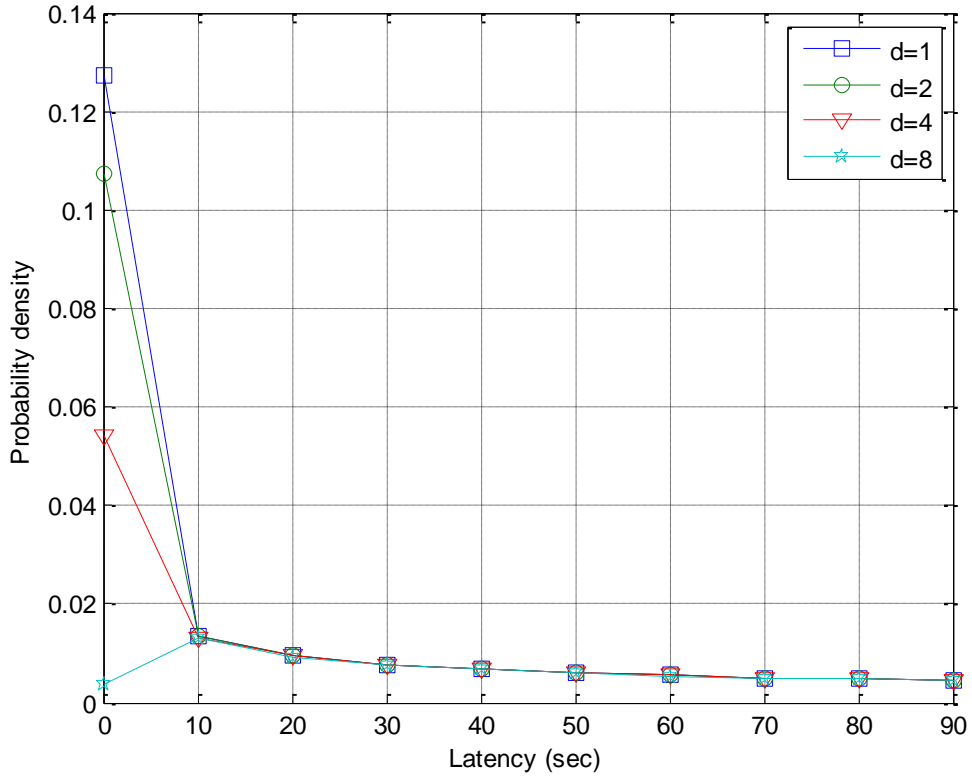

Figure 4.6: The PDF of the latency for blood viscosity at shear rate  $1000s^{-1}$ ,  $\eta=0.31 \times 10^{-2} \left(\frac{kg}{s \cdot m}\right)$ , and  $T=310(K)$  in  $S_{pm} = S_{fluid}$ .

The latency of the propagating molecules is strongly affected by the shear rate in a blood medium. When the shear rate increases, probability density decreases which means that each receiver nanomachine awaits for a long duration for the molecules in a blood medium. Furthermore, when the temperature of the blood increases, propagation time will be more. On the other hand, when the distance between the sender nanomachine and the receiver nanomachine increases, there will be more delays for the propagating molecules in the blood medium.

We then evaluated the PDF of the latency for the propagation process according to the second condition when  $S_{pm} > S_{fluid}$ :

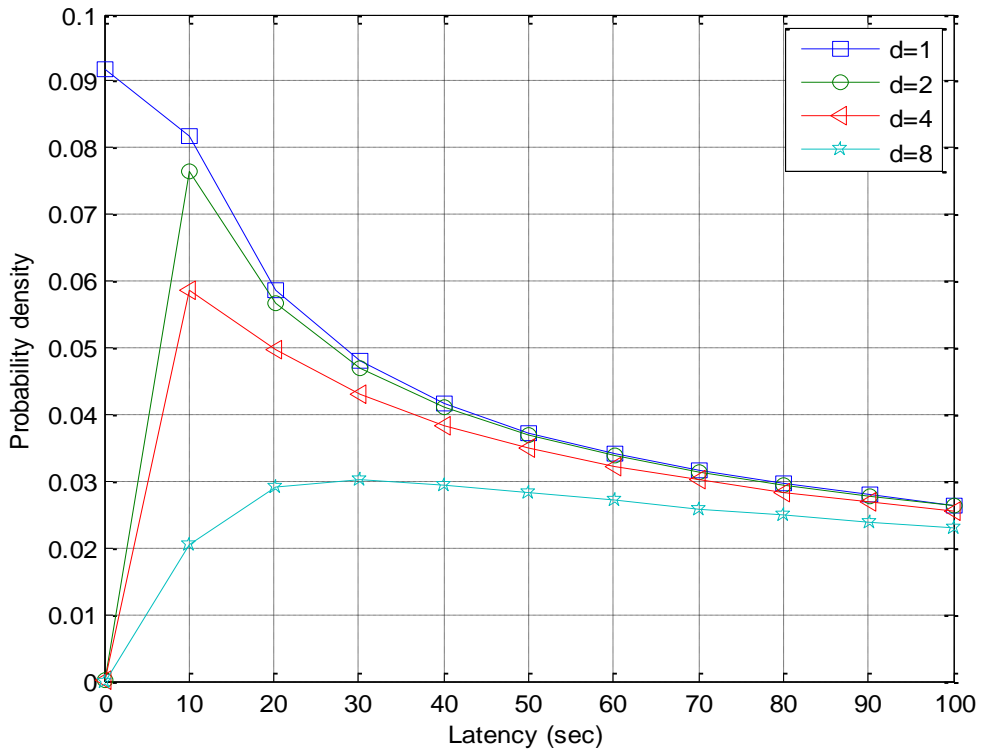

Figure 4.7: The PDF of the latency for blood viscosity at shear rate  $1s^{-1}$ ,  $\eta=7.1\times 10^{-2} (\frac{kg}{s\cdot m})$ , and  $T=277(K)$  in  $S_{pm} > S_{fluid}$ .

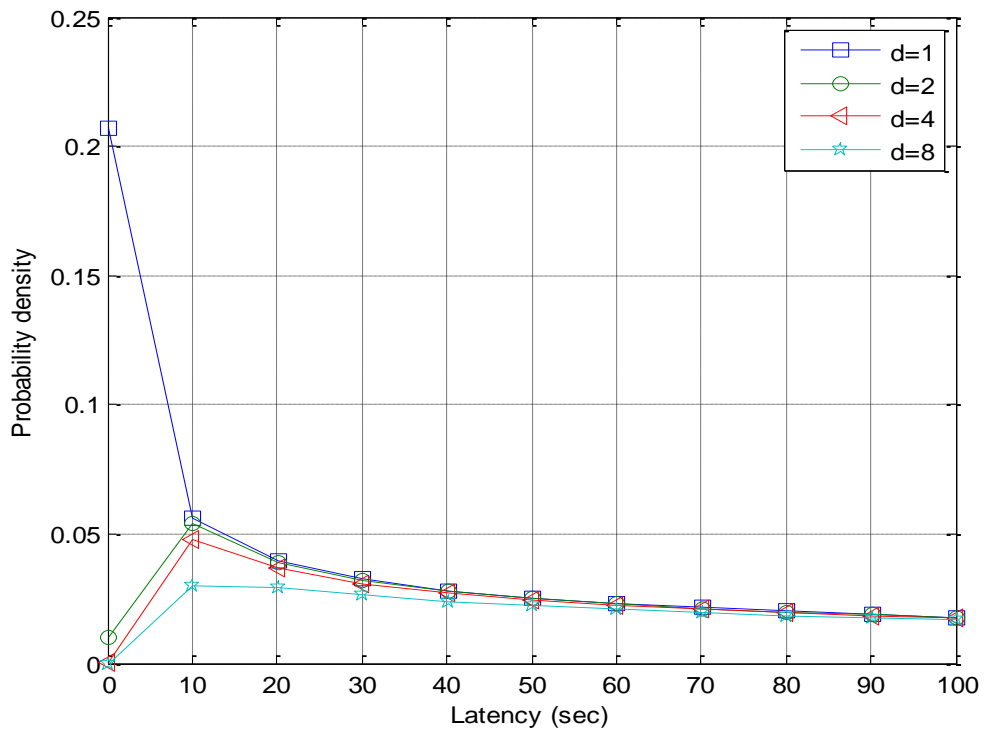

Figure 4.8: The PDF of the latency for blood viscosity at shear rate  $1s^{-1}$ ,  $\eta=3.65\times 10^{-2} (\frac{kg}{s\cdot m})$ , and  $T=310(K)$  in  $S_{pm} > S_{fluid}$ .

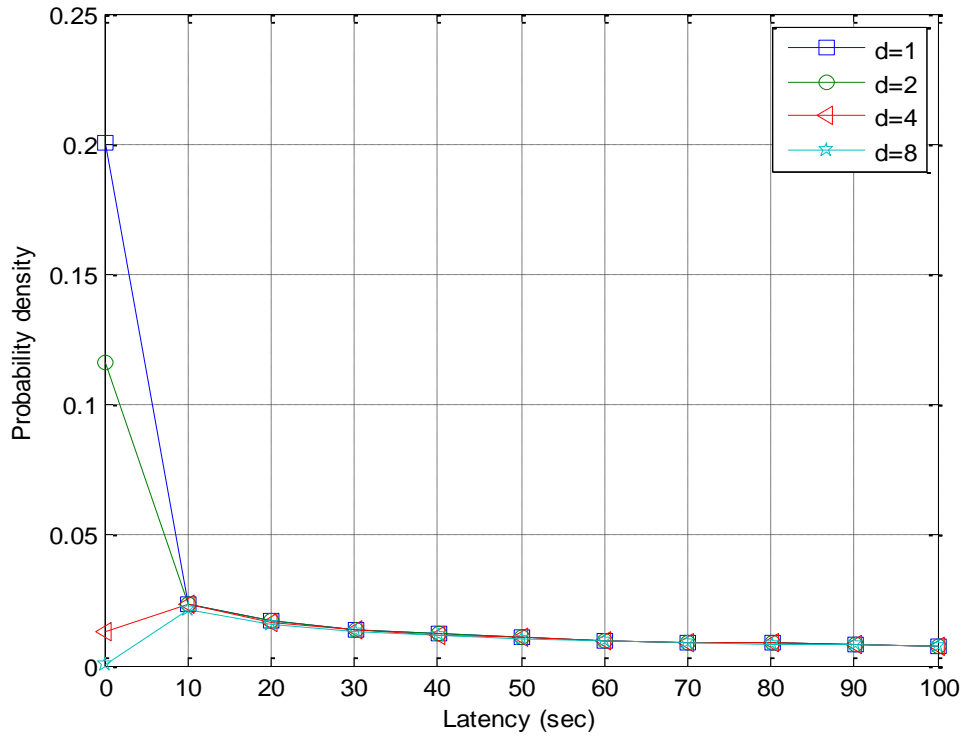

Figure 4.9: The PDF of the latency for blood viscosity at shear rate  $1000s^{-1}$ ,  $\eta=0.583 \times 10^{-2} \left(\frac{kg}{s \cdot m}\right)$ , and  $T=277(K)$  in  $S_{pm} > S_{fluid}$ .

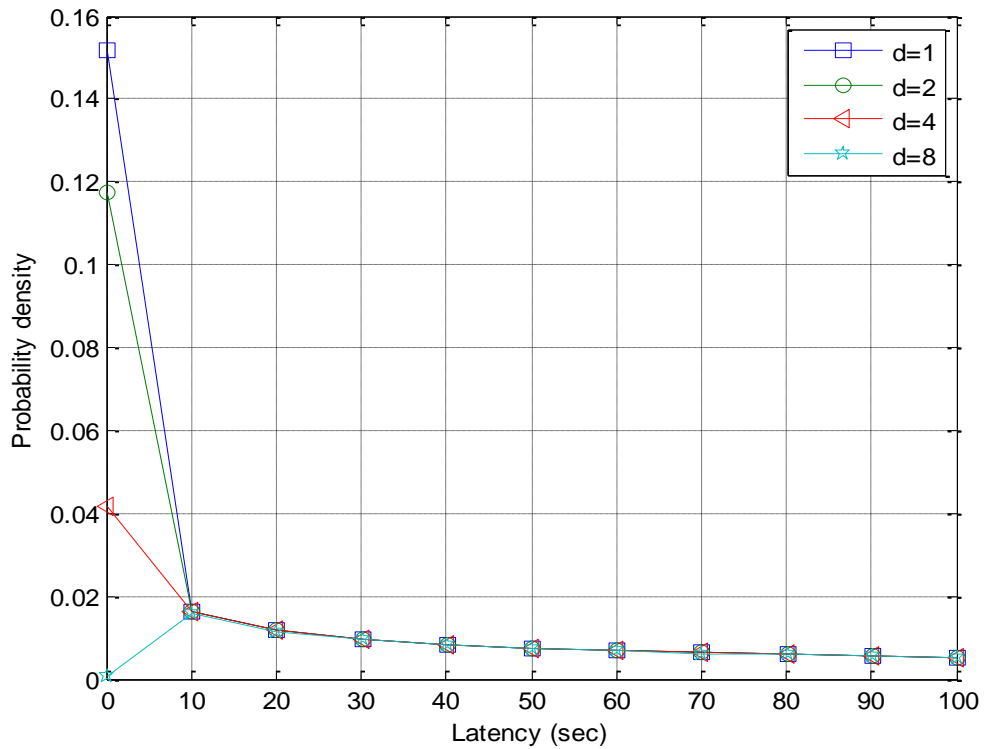

Figure 4.10: The PDF of the latency for blood viscosity at shear rate  $1000s^{-1}$ ,  $\eta=0.31 \times 10^{-2} \left(\frac{kg}{s \cdot m}\right)$ , and  $T=310(K)$  in  $S_{pm} > S_{fluid}$ .



According to the first condition, when the size of the propagating molecules is equal to the size of the molecules of the fluid medium, propagation time will always be more than the second condition ( $S_{pm} > S_{fluid}$ ) for each shear rate of the blood medium. As a result, blood is a more efficient medium for propagation time in  $S_{pm} > S_{fluid}$  at different temperatures.

According to the second condition, ( $S_{pm} > S_{fluid}$ ) during the propagation process, when the temperature of the blood increases, the latency increases accordingly and cause the probability density to decreases for the propagation molecules enabling them to reach to the receiver nanomachine in the blood. For example; the temperature of the blood increases at shear rate  $1000s^{-1}$ , the propagating molecules will then be delayed. Similarly, as the distance between the sender nanomachine and the receiver nanomachine increases, the first hitting time will be more for the propagating molecules. Furthermore, with the increased shear rate of the blood, propagation times differ slightly. The highest probability density of the latency is at shear rate  $1s^{-1}$ .

#### **4.4 PDF of the Latency for Different Blood Shear Rates with Drift**

##### **Velocity**

In this part, we have considered the latency in a blood medium with drift velocity and the distance (d) is a fixed value in our measurements which is equal to  $4(\mu m)$ . In addition, our measured values have been determined by the two conditions:  $S_{pm} = S_{fluid}$  and  $S_{pm} > S_{fluid}$ . First of all, the following figures have been calculated depending on the first condition; ( $S_{pm} = S_{fluid}$ ):

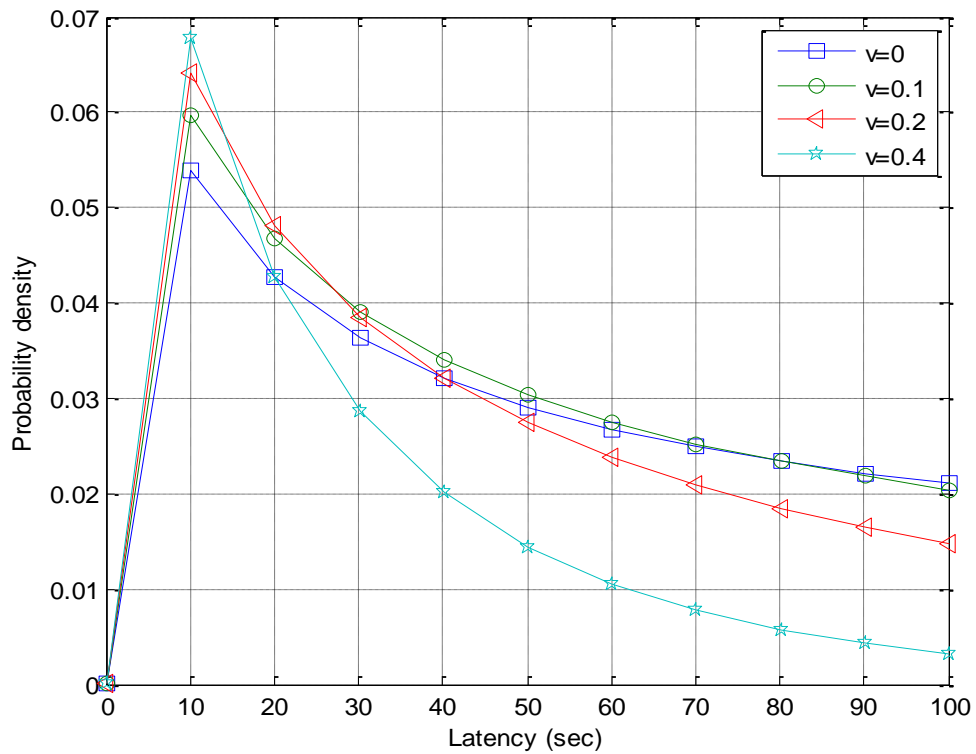

Figure 4.11: The PDF of the latency in a blood medium for different velocity  $v=(0,0.1,0.2,0.4)(\mu\text{m/s})$  and  $d=4(\mu\text{m})$  in  $S_{pm} = S_{fluid}$ ,  $T=277(\text{K})$  at shear rate  $1\text{s}^{-1}$ .

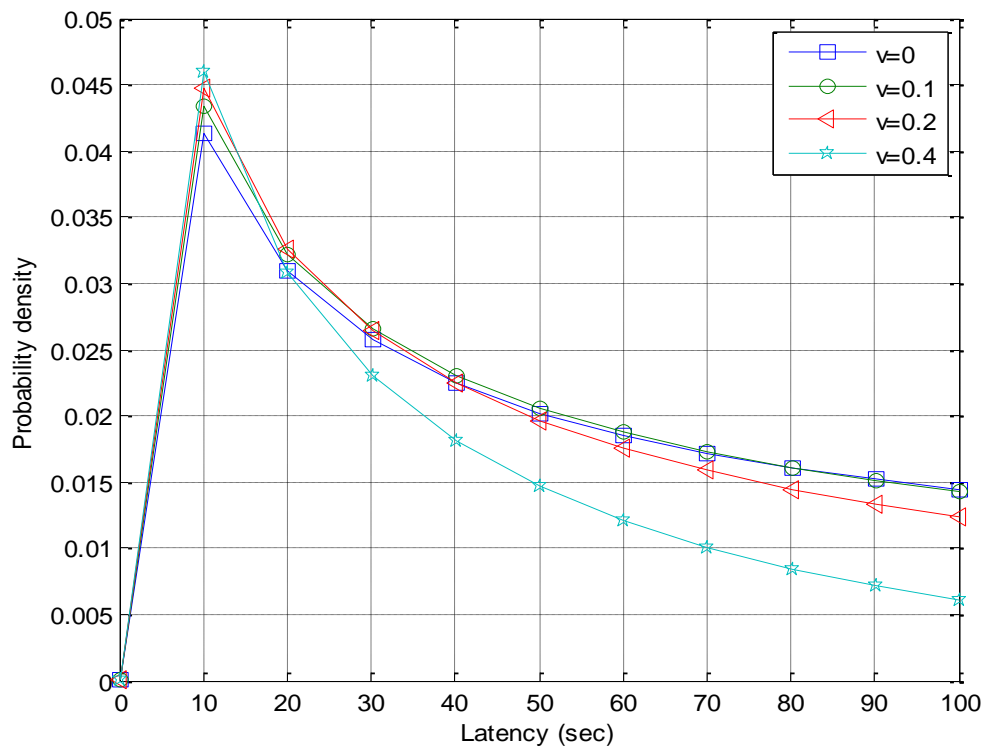

Figure 4.12: The PDF of the latency in a blood medium for different velocity  $v=(0,0.1,0.2,0.4)(\mu\text{m/s})$  and  $d=4(\mu\text{m})$  in  $S_{pm} = S_{fluid}$ ,  $T=310(\text{K})$  at shear rate  $1\text{s}^{-1}$ .

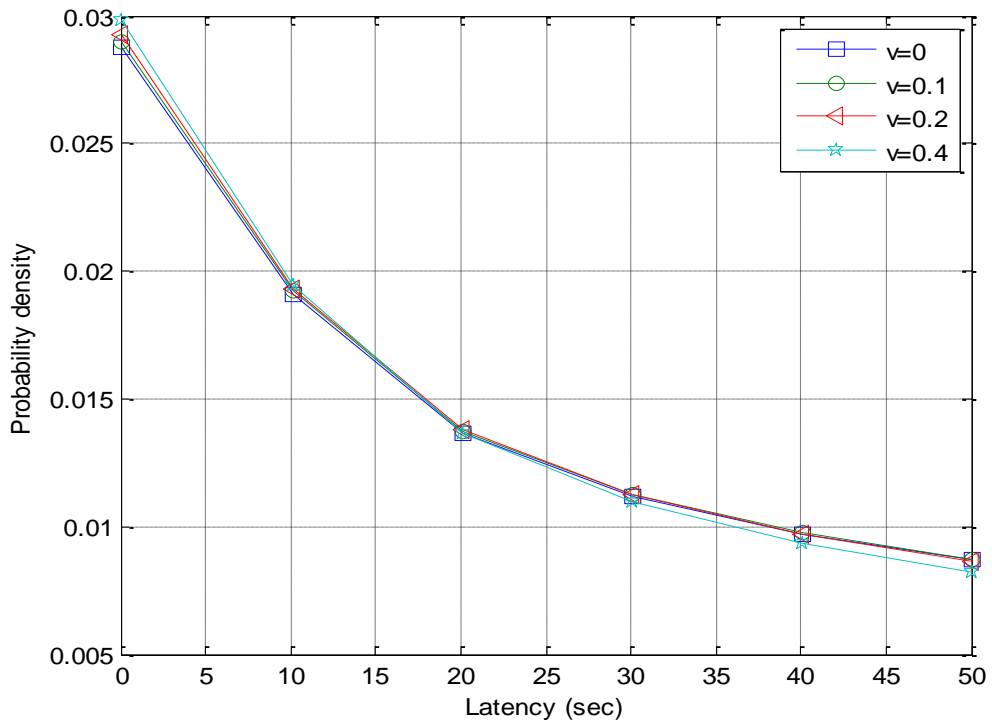

Figure 4.13: The PDF of the latency in a blood medium for different velocity  $v=(0,0.1,0.2,0.4)(\mu\text{m/s})$  and  $d=4(\mu\text{m})$  in  $S_{pm} = S_{fluid}$ ,  $T=277(\text{K})$  at shear rate  $1000\text{s}^{-1}$ .

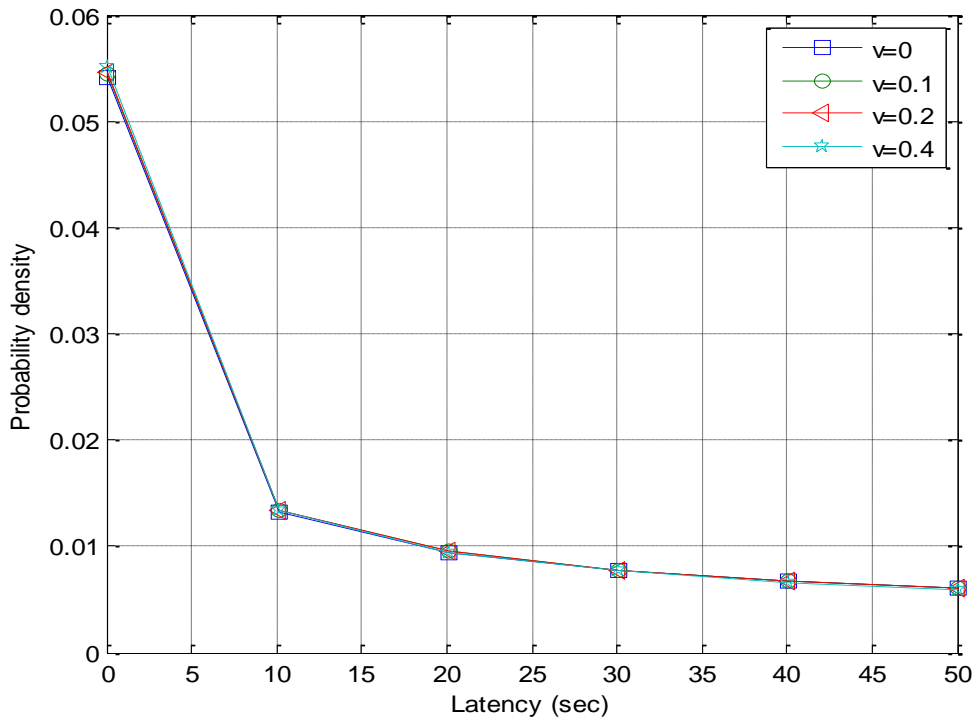

Figure 4.14: The PDF of the latency in a blood medium for different velocity  $v=(0,0.1,0.2,0.4)(\mu\text{m/s})$  and  $d=4(\mu\text{m})$  in  $S_{pm} = S_{fluid}$ ,  $T=310(\text{K})$  at shear rate  $1000\text{s}^{-1}$ .

According to the results, when the drift velocity of the blood increases, the propagation time decreases for the propagating molecules in the same distance. However, the temperature of the blood increases, propagation time also increases during the propagation process. Similarly, when the shear rate of the blood increases, latency of the propagating molecules also increases and the probability density decreases as a result the receiver nanomachine waits for a long time to receive an information molecule. When the shear rate of the blood increases, the differences of latency are very slight. Blood, therefore, becomes an efficient medium at low shear rates in decreased temperatures.

The following figures have been evaluated by taking the second condition;  $S_{pm} > S_{fluid}$  into consideration.

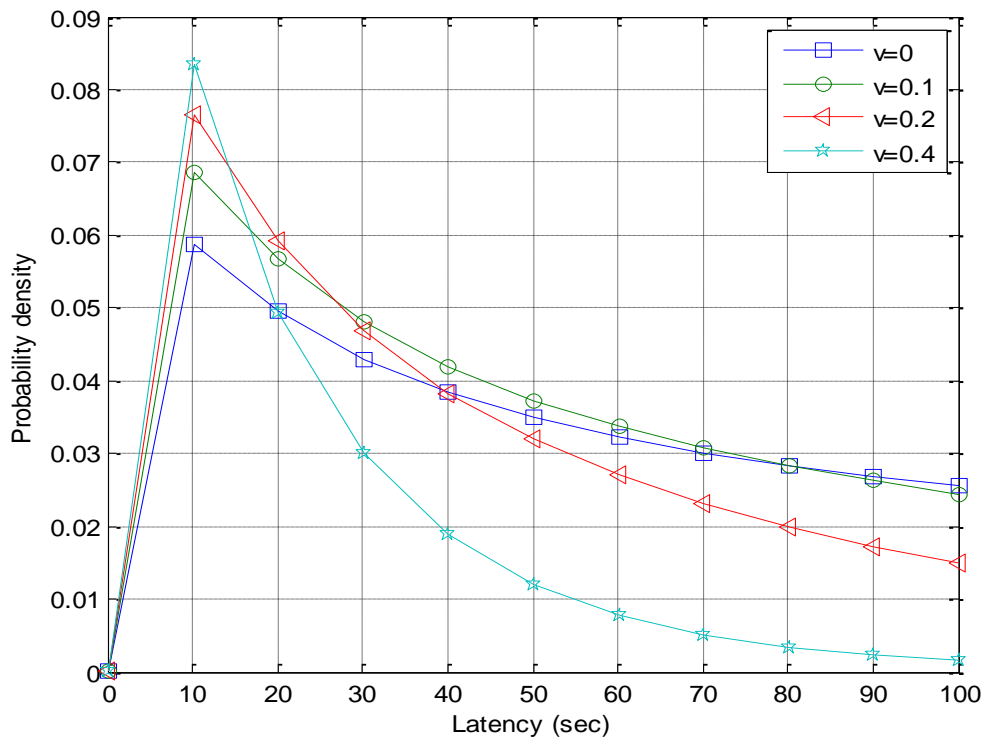

Figure 4.15: The PDF of the latency in a blood medium for different velocity  $v=(0,0.1,0.2,0.4)(\mu\text{m/s})$  and  $d=4(\mu\text{m})$  in  $S_{pm} > S_{fluid}$ ,  $T=277(\text{K})$  at shear rate  $1\text{s}^{-1}$ .

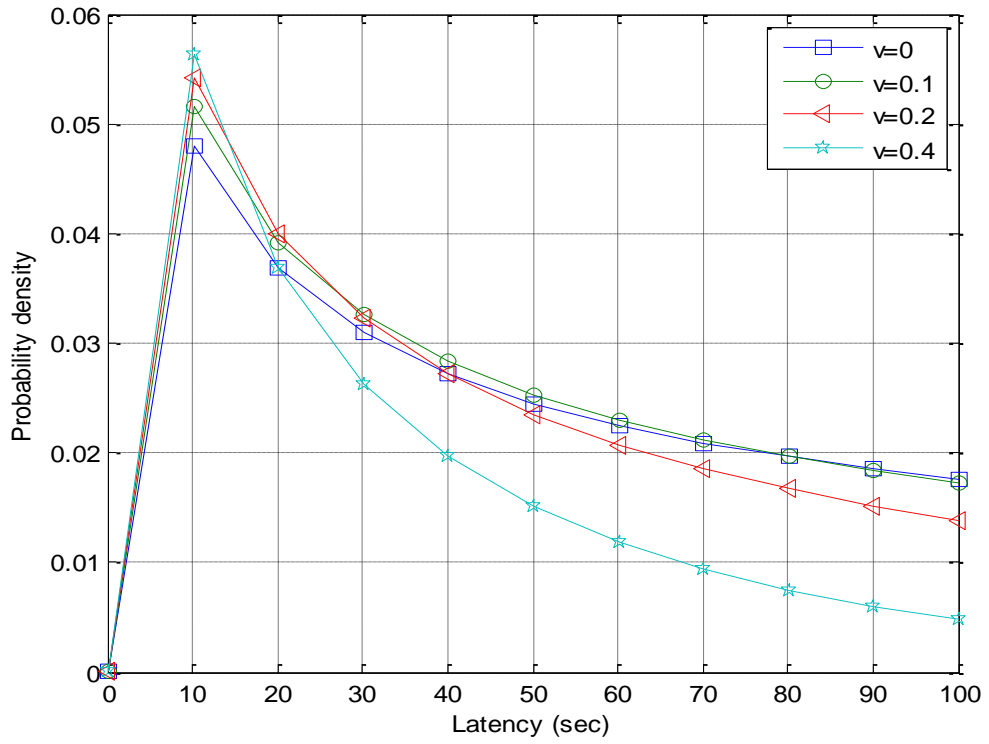

Figure 4.16: The PDF of the latency in a blood medium for different velocity  $v=(0,0.1,0.2,0.4)(\mu\text{m/s})$  and  $d=4(\mu\text{m})$  in  $S_{pm} > S_{fluid}$ ,  $T=310(\text{K})$  at shear rate  $1\text{s}^{-1}$ .

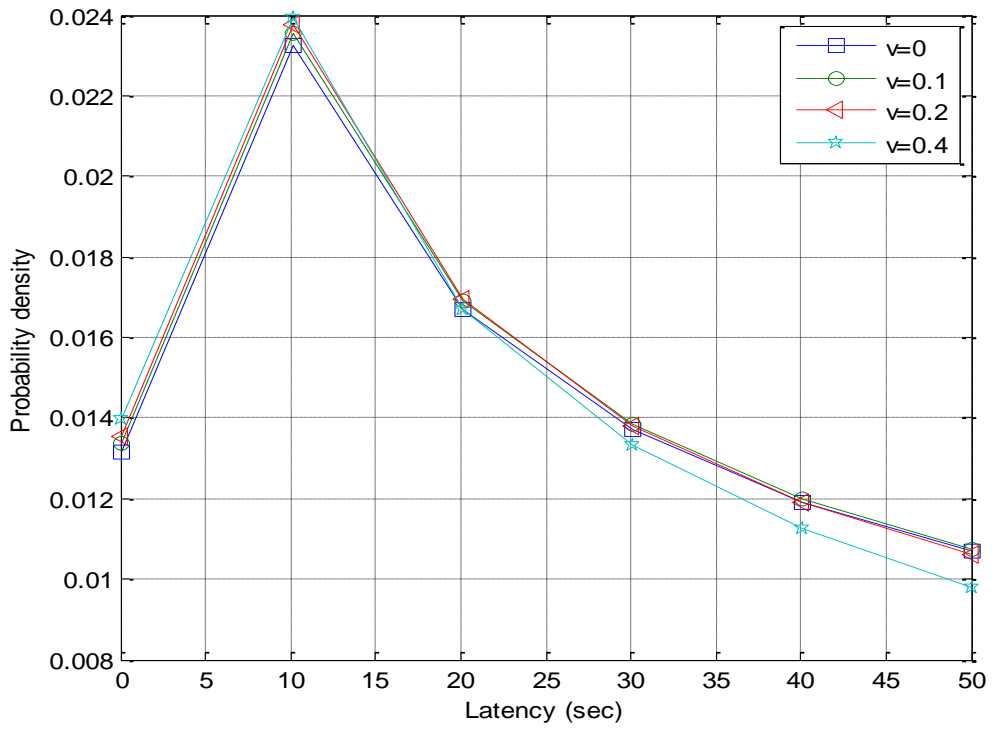

Figure 4.17: The PDF of the latency in a blood medium for different velocity  $v=(0,0.1,0.2,0.4)(\mu\text{m/s})$  and  $d=4(\mu\text{m})$  in  $S_{pm} > S_{fluid}$ ,  $T=277(\text{K})$  at shear rate  $1000\text{s}^{-1}$ .

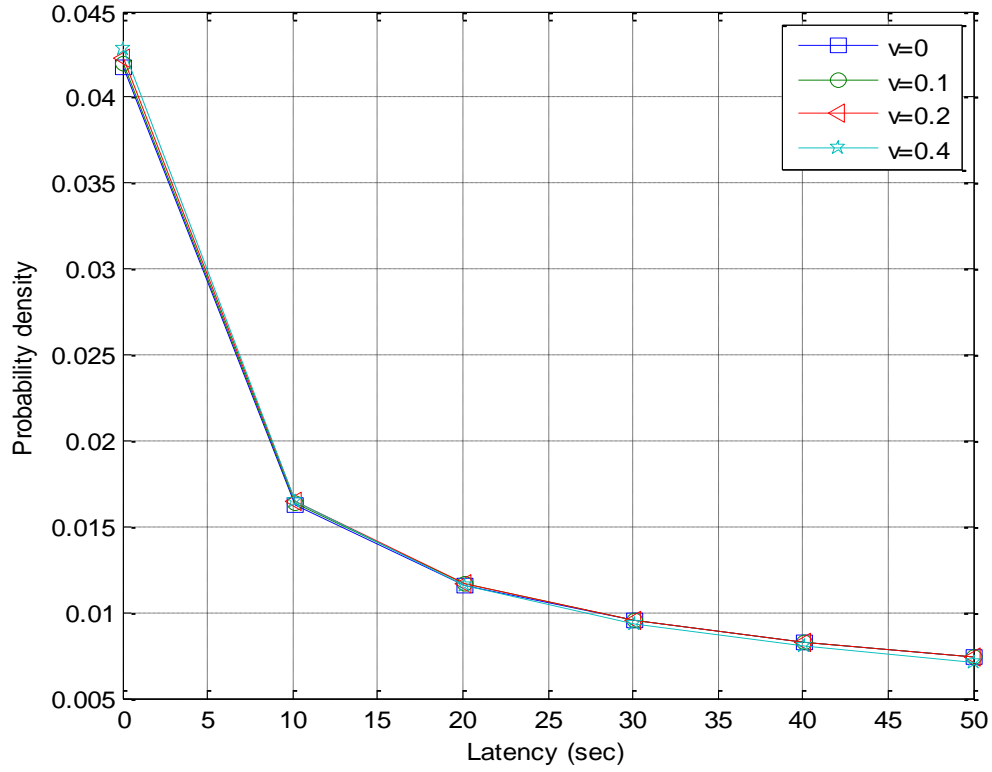

Figure 4.18: The PDF of the latency in a blood medium for different velocity  $v=(0,0.1,0.2,0.4)(\mu\text{m/s})$  and  $d=4(\mu\text{m})$  in  $S_{pm} > S_{fluid}$ ,  $T=310(\text{K})$  at shear rate  $1000s^{-1}$ .

Here, as the velocity of the blood increases, the propagation time decreases for the propagating molecules in blood and when the shear rate of the blood increases, the latency of the propagating molecules also increases. Blood becomes an efficient medium in low temperatures and the shear rate has to be small for low propagation time. The differences in drift velocities are very close to that of each others at the high shear rate;  $1000s^{-1}$ .

According to the results, the  $S_{pm} = S_{fluid}$  in blood, results in a longer propagation time compared to the other condition. In other words, the  $S_{pm} > S_{fluid}$  in blood reduces the first hitting time than that of the other condition; meaning the latency of the propagation molecules will be always less for propagating molecules. The

latency of the propagating molecules goes to the infinity in both conditions. By looking at the results we can conclude that the latency of the blood medium at shear rate  $1000s^{-1}$  will always be higher than that of at shear rate  $1s^{-1}$  for both conditions during the propagation process. When  $S_{pm} > S_{fluid}$  during the propagation process, the blood becomes an efficient medium in low temperatures.

#### 4.5 Comparison of Different Blood Shear Rates

In this part, we compare different shear rates in a blood medium for the PDF of latency. In addition, when  $S_{pm} = S_{fluid}$  during the propagation process in blood, the following figures are used to compare the different blood shear rates.

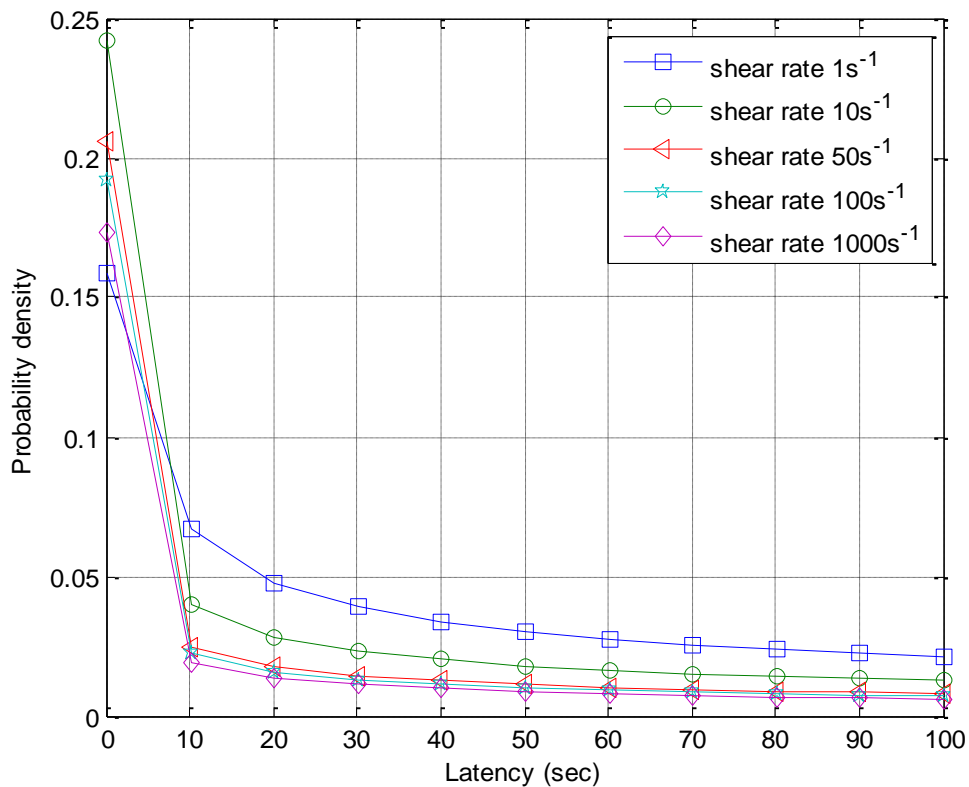

Figure 4.19: The PDF of the latency for blood viscosity at different shear rates in  $d=1(\mu m)$ , and  $T=277(K)$  in  $S_{pm} = S_{fluid}$ .

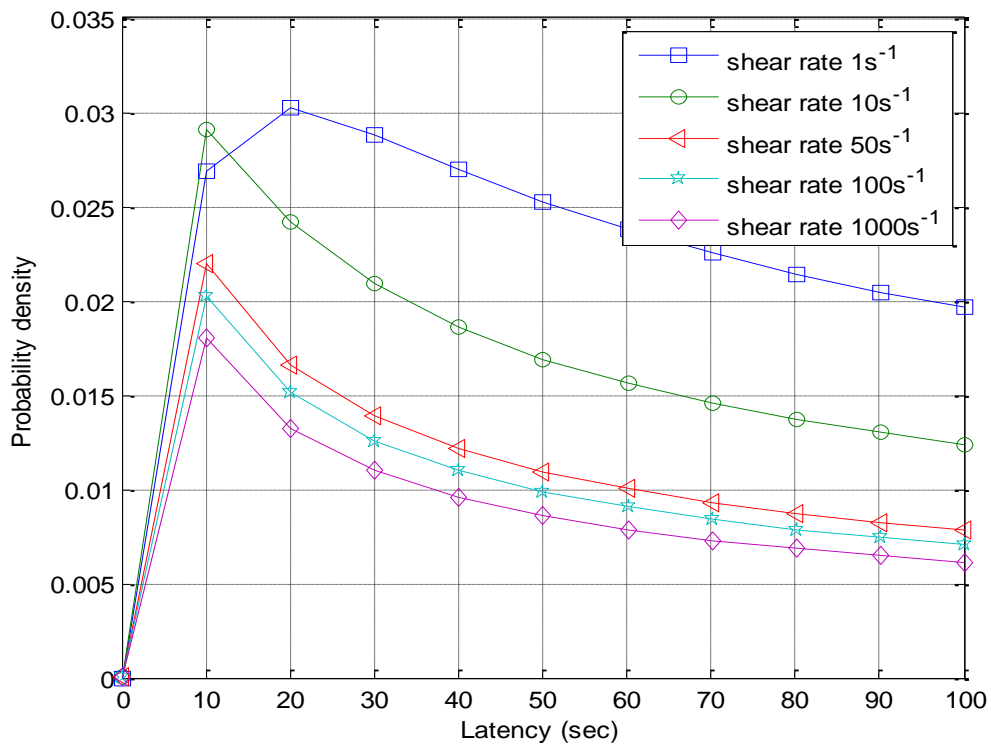

Figure 4.20: The PDF of the latency for blood viscosity at different shear rates in  $d=8(\mu\text{m})$ , and  $T=277(\text{K})$  in  $S_{pm} = S_{fluid}$ .

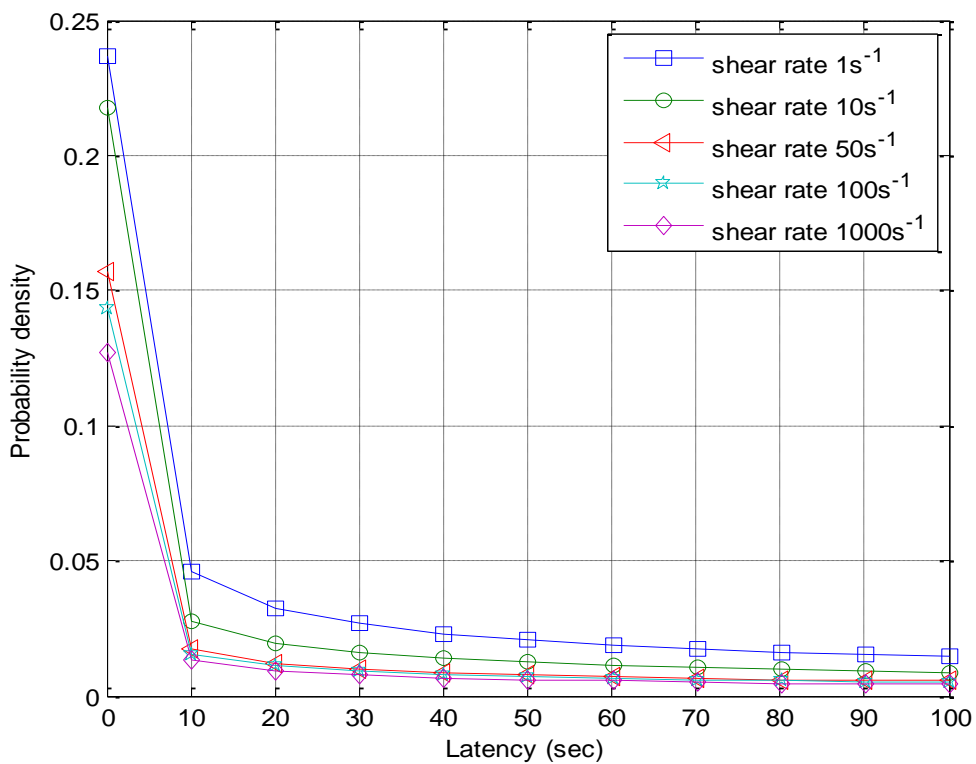

Figure 4.21: The PDF of the latency for blood viscosity at different shear rates in  $d=1(\mu\text{m})$ , and  $T=310(\text{K})$  in  $S_{pm} = S_{fluid}$ .



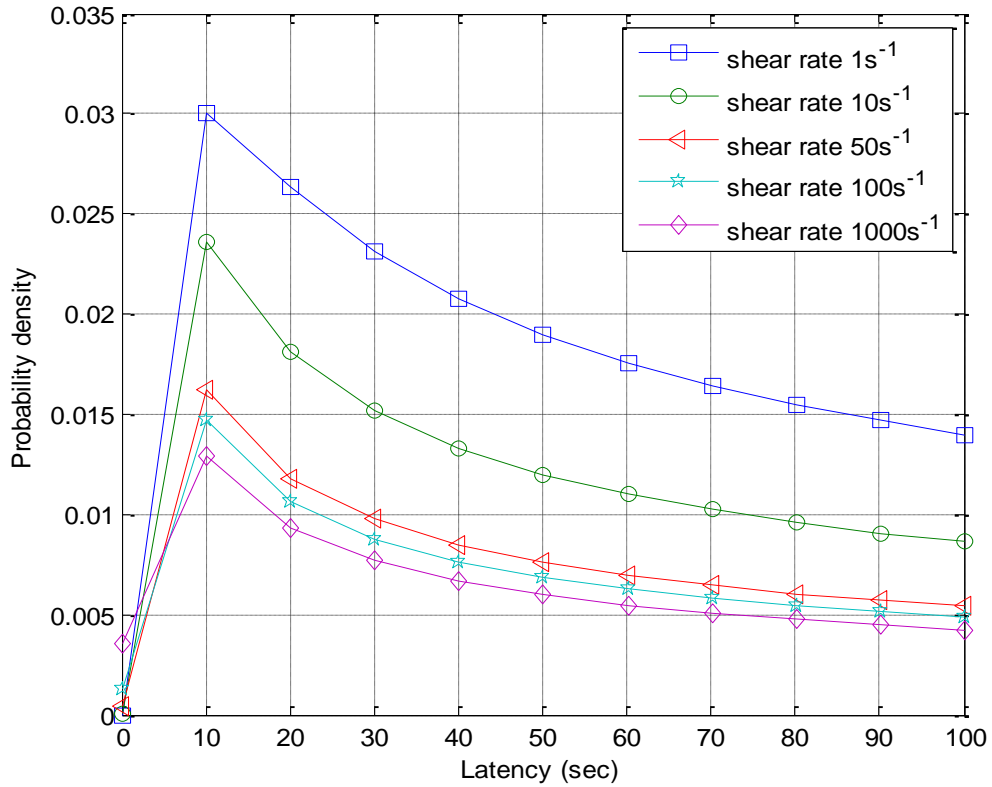

Figure 4.22: The PDF of the latency for blood viscosity at different shear rates in  $d=8(\mu\text{m})$ , and  $T=310(\text{K})$  in  $S_{pm} = S_{fluid}$ .

According to the first condition ( $S_{pm} = S_{fluid}$ ), the propagation time is strongly affected by the distance for each blood shear rate. When the shear rate of blood increases, the probability density decreases for the propagating molecules. When the distance increases between the sender nanomachine and the receiver nanomachine, the latency of the propagating molecules also increases. The blood medium is an efficient medium for long distances. The blood medium has a higher probability in low temperatures at the low shear rates. When the temperature of the blood increases, the latency increases for the propagating molecules for each shear rates.

Later, the following figures are analyzed looking at the second condition;  $S_{pm} > S_{fluid}$ .

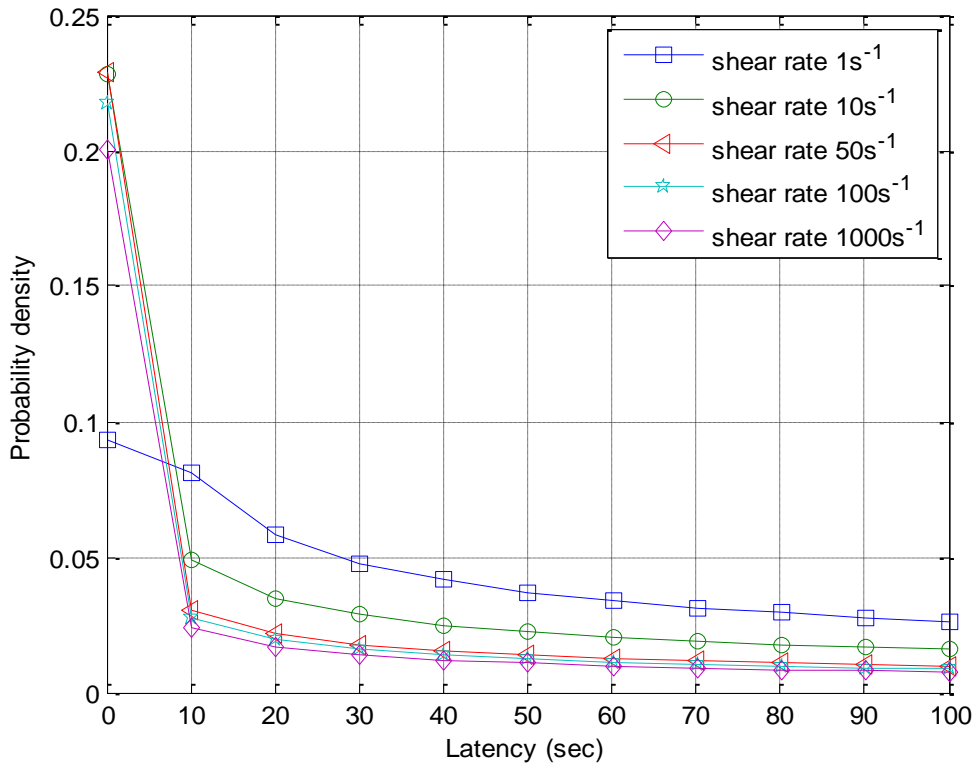

Figure 4.23: The PDF of the latency for blood viscosity at different shear rates in  $d=1(\mu\text{m})$ , and  $T=277(\text{K})$  in  $S_{pm} > S_{fluid}$ .

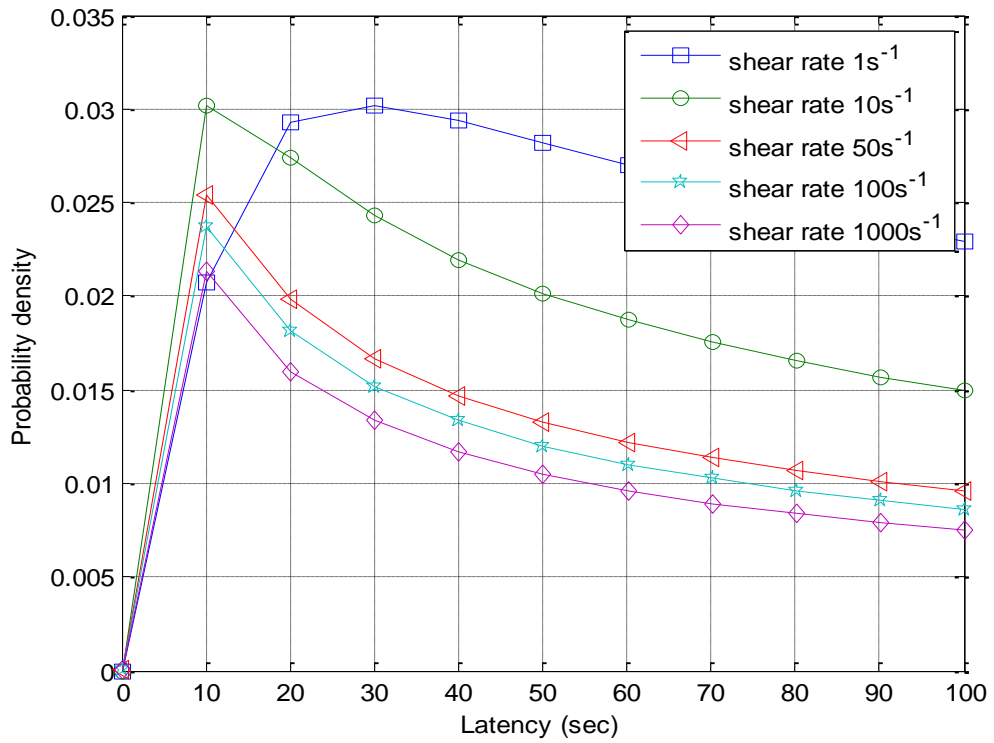

Figure 4.24: The PDF of the latency for blood viscosity at different shear rates in  $d=8(\mu\text{m})$ , and  $T=277(\text{K})$  in  $S_{pm} > S_{fluid}$ .

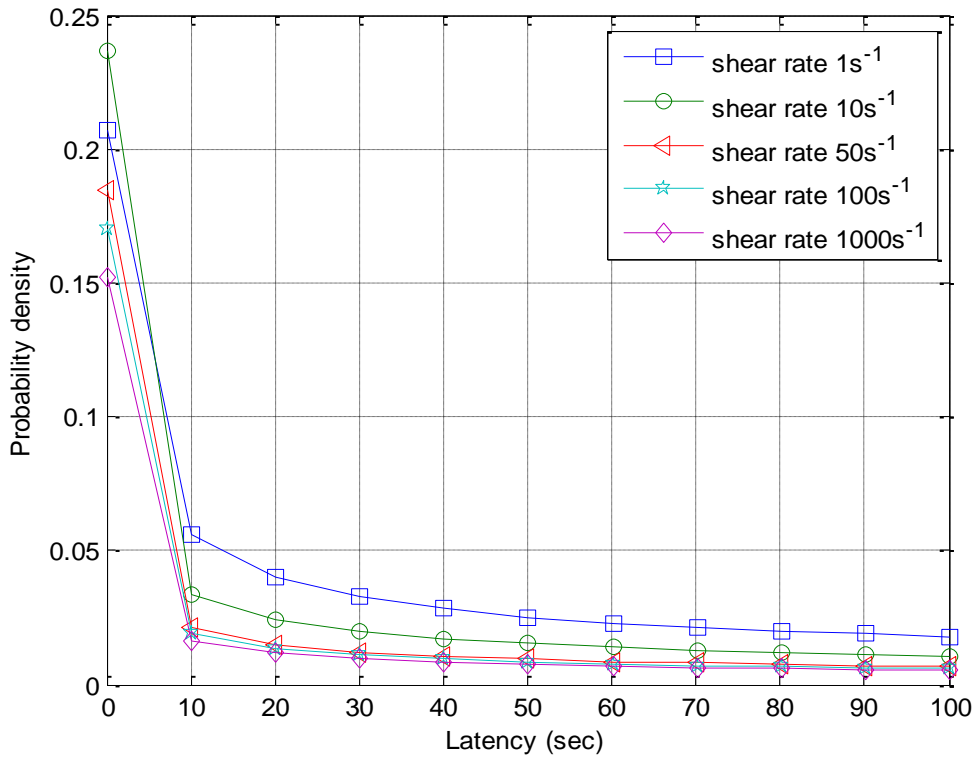

Figure 4.25: The PDF of the latency for blood viscosity at different shear rates in  $d=1(\mu\text{m})$ , and  $T=310(\text{K})$  in  $S_{pm} > S_{fluid}$ .

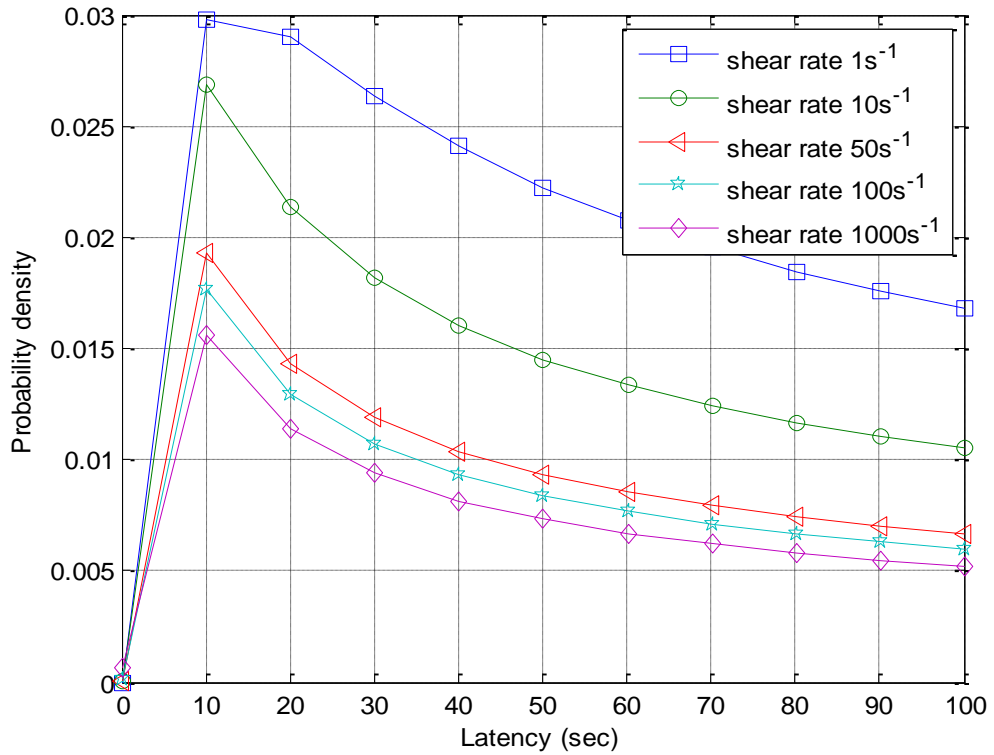

Figure 4.26: The PDF of the latency for blood viscosity at different shear rates in  $d=8(\mu\text{m})$ , and  $T=310(\text{K})$  in  $S_{pm} > S_{fluid}$ .

According to the second condition ( $S_{pm} > S_{fluid}$ ), the probability density of the latency is always more than that of the first condition; ( $S_{pm} = S_{fluid}$ ) at the same temperatures. The latency is strongly affected by the shear rate of the blood medium. On the other hand, low shear rates are more affected than high shear rates for the latency of propagating molecules over long distances in the blood medium. When the shear rate of the blood increases, propagation time is more for the propagating molecules. After the distance between the sender and the receiver nanomachines increases, propagation time is always more for the each shear rate of blood, at the same temperature.

By looking at these results, we can say that when the distance between the sender nanomachine and the receiver nanomachines increases, so does the latency of the propagating molecules for each shear rate. If the temperature of blood increases, the probability density of the propagating molecules decreases. It means that, the first hitting time is delayed more for the propagating molecules in high temperatures of blood. That is to say, the blood medium at shear rate  $1s^{-1}$  has the highest probability value at the first hitting time of the propagating molecules to the receiver nanomachine in each figure. As a result, the latency of the propagating molecules is strongly affected by the distance ( $d$ ) between the sender nanomachine and the receiver nanomachine.

#### **4.6 The PDF of the Latency in a Water Medium**

Here we compare the blood and the water mediums for the propagation model. Our numerical results are based on the condition  $S_{pm} \gg S_{fluid}$  owing to its most widely used condition in molecular communication.

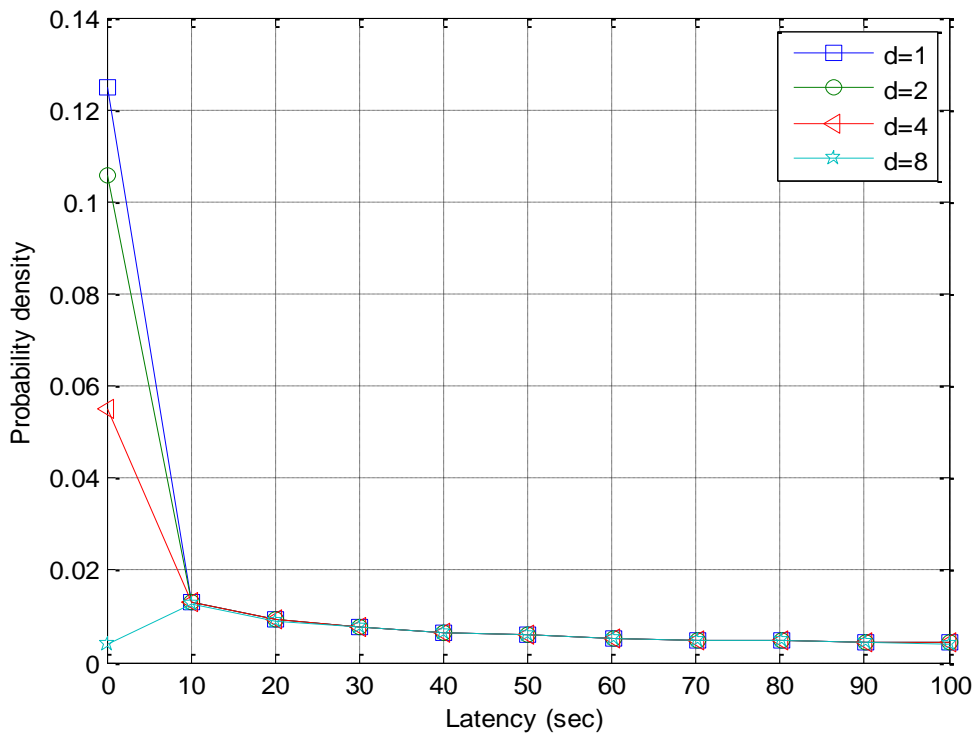

Figure 4.27: The PDF of the latency for water at  $T=273(K)$  and  $\eta=0.001742$  in  $S_{pm} > S_{fluid}$ .

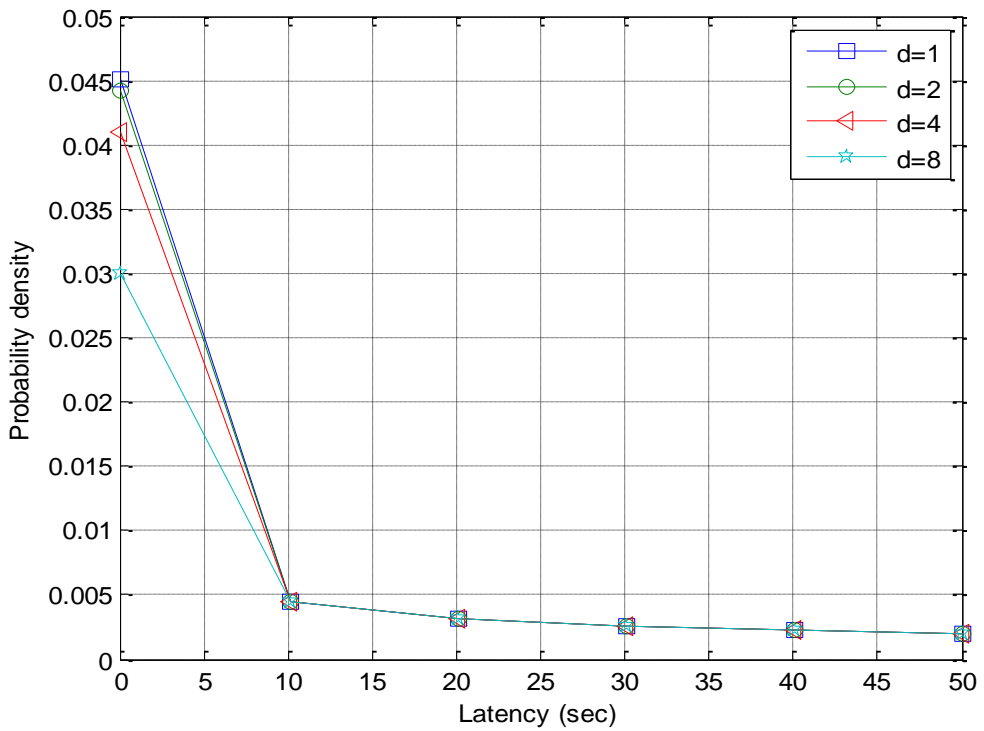

Figure 4.28: The PDF of the latency for water at  $T=373(K)$  and  $\eta=0.0002836$  in  $S_{pm} > S_{fluid}$ .

According to  $S_{pm} > S_{fluid}$  condition, the latency goes to infinity for a long time meaning that the receiver nanomachine waits for a long time before receiving the propagating molecule. When the temperature of the water increases, the probability density decreases for the propagating molecules. The figures illustrate that all probability density results are very close to each other in different temperatures. The distance between the sender and the receiver nanomachines increases, then the probability density stays the same for a long time. When considering the latency in a water medium taking drift velocity into account, the distance (d) is then a fixed value in our measurement which is equal to  $1(\mu\text{m})$ .

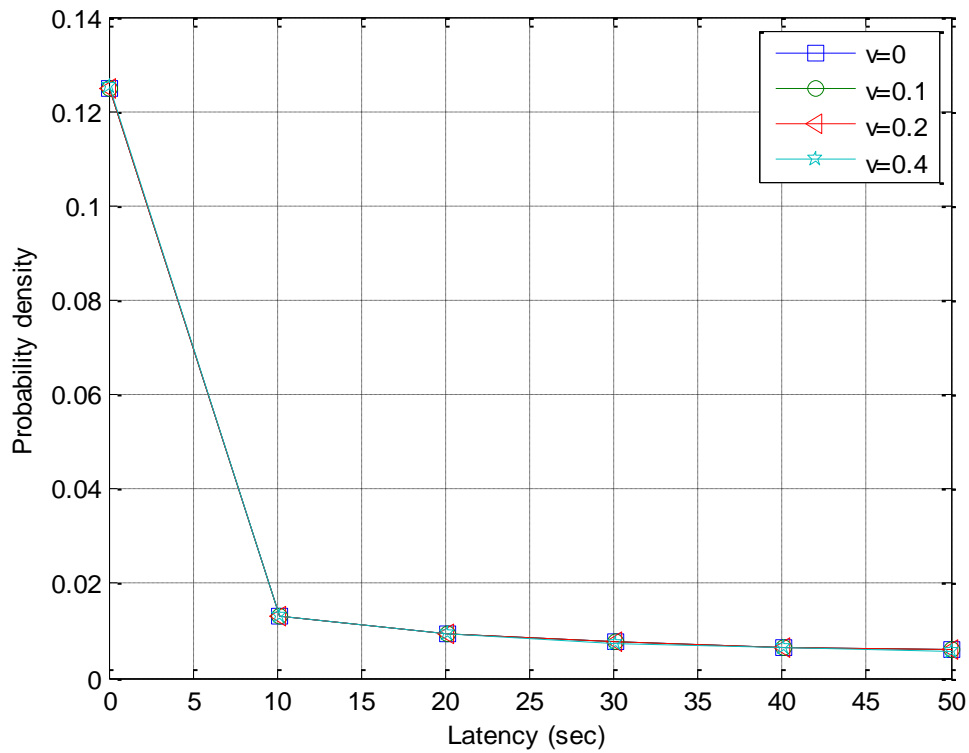

Figure 4.29: The PDF of the latency for water at  $T=273(\text{K})$  for different velocity  $v=\{0,0.1,0.2,0.4\}(\mu\text{m/s})$  and  $d=1(\mu\text{m})$  in  $S_{pm} > S_{fluid}$ .

The figure shows that after the velocity of water increases, all probability density results come very close to each other and there is no difference for the latency of the propagating molecules. We want to determine the PDF of the latency for different

distances with different temperatures based on the  $S_{pm} \gg S_{fluid}$  conditions, the following figures, then, represent the latency of the propagating molecules with different temperatures in a small distance.

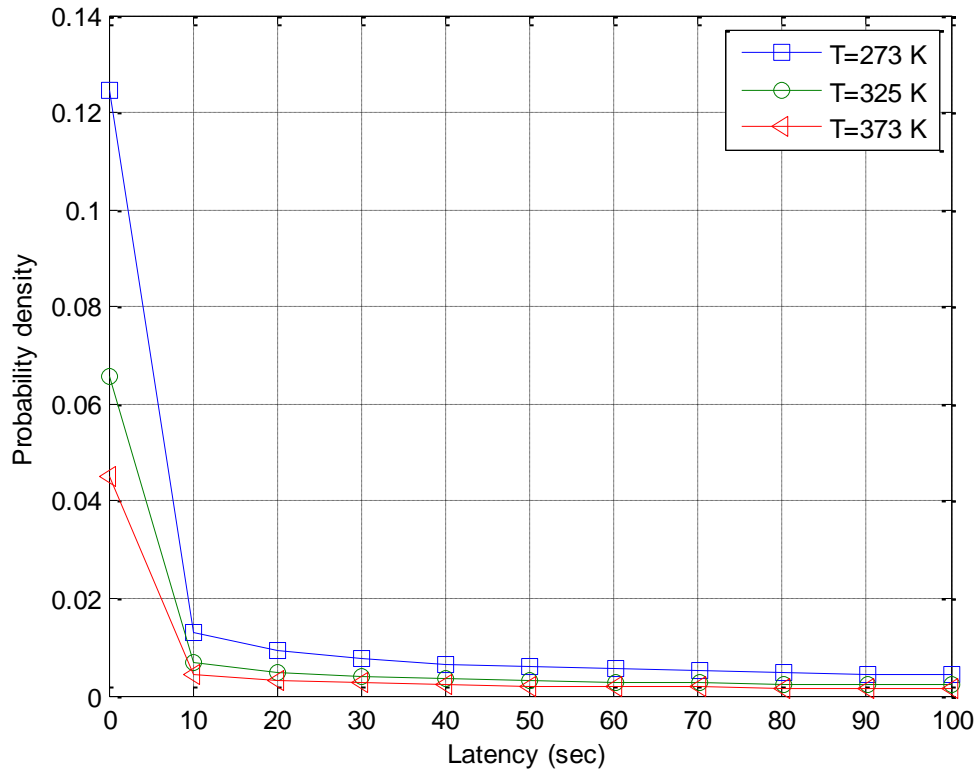

Figure 4.30: The PDF of the latency for water in different temperatures in  $S_{pm} > S_{fluid}$  and  $d=1(\mu\text{m})$ .

In Figure 4.30, when the temperature of the water increases, the probability density for the propagating molecules decreases. The figure illustrates how latency goes to infinity for a long time meaning that the receiver nanomachine waits for a long time before receiving the propagating molecules. The following figures represent the latency under different temperatures for a long distance.

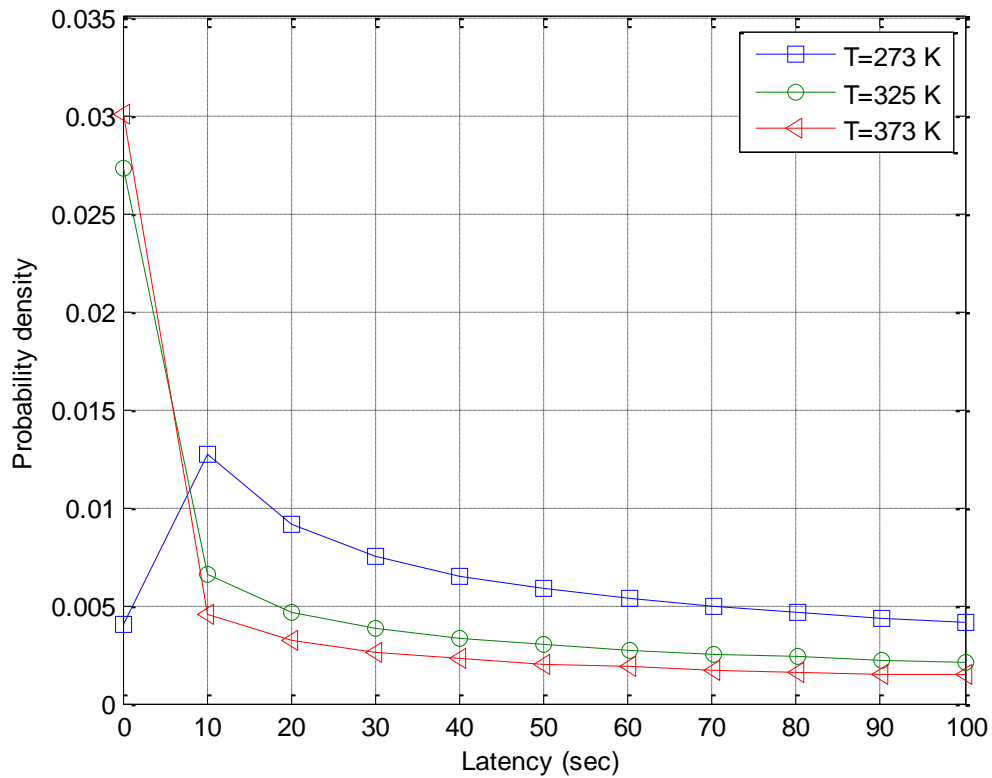

Figure 4.31: The PDF of the latency for water in different temperatures in  $S_{pm} > S_{fluid}$  and  $d=8(\mu\text{m})$ .

The figure shows the increasing temperature of water causing a decrease in the probability density of the propagating molecules. The latency is too much for the propagating molecules.

According to the results, when the distance between the sender and receiver nanomachines increases, the probability density for the propagating molecules decreases. As seen in the figures, when the temperature of the water increases, the probability density decreases for a long duration of time. For the propagating molecules, the numerical results are very close to each other in water medium.



## **Chapter 5**

### **CONCLUSION**

Nano-communication or molecular communication, in other words, the use of molecules to encode and transmit information among nanomachines, is a new communication paradigm. Communication among these nano-devices extends the capabilities and usages of individual devices both in content and range of operation, hence enabling new applications of nanotechnology in the medical, environmental and military fields as well as in consumer and industrial goods. However, it requires providing new theoretical models to design new systems. Biophysics makes use of many theoretical models such as quantum physics [2]. The area of biophysics can be used to generate new theoretical models for molecular communication. Molecular communication needs to provide new applications in every field especially in medical applications. The most important expectation of molecular communication is to provide new solutions for the treatment of cancer in a near future since the molecular communications research is investigating communication for nano scale devices in biological environment. This area of the nano-communication needs to evaluate the biological systems and models and to work hand in hand with the traditional communication models, however. We can say that nano-communication will have a great impact, with high potential capacity, on many different areas in the very near future.

In this thesis, we proposed an analytical model for the propagation process of molecular communication under different diffusion coefficient conditions in blood and water. We then derived a general formula for the PDF of the propagating molecules latency which takes into account the crucial parameters: the distance between the sender and the receiver, radius of the propagating molecules, viscosity, velocity, and temperature of the fluid medium with different shear rates. Based on the performed numerical analysis, the latency of the model is highly affected by the distance ( $d$ ) between the sender and the receiver nanomachines in blood. The drift velocity has a great impact on the probability density of the latency for the insulin molecules in the blood medium. We then demonstrated the latency behavior under different viscosity conditions with different blood shear rates and temperatures in the blood medium. The PDF of the latency for the water is also evaluated.

The main contribution of the thesis is to propose a theoretical propagation model with realistic diffusion coefficient for molecular communication which is based on random walk model. We first formulated the PDF function of the latency with diffusion coefficient parameters in blood and water. We also analyze the comparison of different blood shear rates and temperatures using insulin molecule. Finally, we conclude that the latency is achievable under different viscosity conditions during the propagation process.

Future work will involve further investigation of the PDF of the latency with different kinds of molecules such as glycogen. The objective of the ongoing research on nano communication is still at the theoretical modeling of nanomachines to develop new mechanism based on the area of biophysics [5].

## REFERENCES

- [1] I. F. Akyildiz, F. Brunetti, and C. Blázquez, "Nanonetworks: A new communication paradigm," *Computer Networks*, vol. 52, no. 12, pp. 2260-2279, 2008.
- [2] T. Nakano, M. J. Moore, F. Wei, A. V. Vasilakos, and J. Shuai, "Molecular Communication and Networking: Opportunities and Challenges," *Nanobioscience*, vol. 11, no. 2, pp. 135-148, 2012.
- [3] I. F. Akyildiz, J. M. Jornet, and M. Pierobon, "Propagation Models for Nanocommunication Networks," *Proceedings of the Fourth European Conference on Antennas and Propagation(EuCAP)*, pp. 1-5, 2010.
- [4] T. Nakano, M. Moore, A. Enomoto, and T. Suda, "Molecular Communication Technology as a Biological ICT," *Biological Functions for Information and Communication Technologies*, pp. 49-86, 2011.
- [5] S. Hiyama, Y. Moritani, T. Suda, R. Egashira, R. Enomoto, M. Moore, and T. Nakano, "Molecular Communication," *Nanotechnology Conference*, pp. 391-394, 2005.
- [6] F. Walsh, S. Balasubramaniam, D. Botvich, T. Suda, T. Nakano, S. F. Bush, and M. O. Foghlu, "Hybrid DNA and enzymatic based computation for address encoding, link switching and error correction in molecular communication," *Third International Conference on Nano-Networks and Workshops*, 2008.

- [7] T. Suda, M. Moore, T. Nakano, R. Egashira, and A. Enomoto, "Exploratory research on molecular communication between nanomachines," in *Genetic and Evolutionary Computation Conference (GECCO), Late Breaking Papers*, June 2005.
- [8] H. Goldstein, "The race to the bottom," vol. 42, no. 3, pp. 32-39, 2005.
- [9] M. Meyyappan, J. Li, and A. Casselle, "Nanotechnology: An overview and integration with MEMS," in *Proceedings of the 19th IEEE International Conference on Micro Electro Mechanical Systems*, 2006.
- [10] C. Peterson, "Taking technology to the molecular level," *IEEE Computer* 33, vol. 33, no. 1, pp. 46-53, 2000.
- [11] E. Drexler, C. Peterson, and G. Pergami, "Unbounding the future: The nanotechnology revolution," Foresight Institute, Technical Report, 1991.
- [12] G. Whitesides, "The once and future nanomachine," *Scientific American*, pp. 77-83, 2001.
- [13] J. Smith, The concept of information in biology. *Philos. Sci.* 67(2), 177–194, 2000.
- [14] T. Suda, M. Moore, T. Nakano, R. Egashira, and A. Enomoto, "Exploratory research on molecular communication between nanomachines" in *Genetic and Evolutionary Computation Conference, Late-breaking Papers* (ACM press, New York), 2005.

- [15] Y. Moritani, S. Hiyama, and T. Suda, "Molecular communication among nanomachines using vesicles" in *NSTI Nanotechnology Conference and Trade Show* (NSTI, Cambridge), 2006.
- [16] M. Moore, A. Enomoto, T. Suda, T. Nakano, and Y. Okaie, "Molecular communication: New paradigm for communication among nano-scale biological machines" in *The Handbook of Computer Networks*. Hoboken, NJ: Wiley, vol. 3, pp. 1034–1054, 2007.
- [17] H. C. Berg, *Random Walks in Biology*. Princeton Univ. Press: Princeton University Press, 1993.
- [18] M. Pierobon and I. F. Akyildiz, "A physical channel model for molecular communication in nanonetworks," *IEEE Journal on Selected Areas in Communications*, vol. 28, no. 4, pp. 602-611, 2010.
- [19] S. Kadloor, R. S. Adve, and A. W. Eckford, "Molecular communication using Brownian motion with drift," *IEEE Trans. Nanobioscience*, vol. 11, no. 2, pp. 89–99, Jun. 2012.
- [20] Y. Okaie, T. Nakano, T. Hara, and S. Nishio, "Distributing Nanomachines for Minimizing Mean Residence Time of Molecular Signals in Bionanosensor Networks," *Sensors Journal, IEEE*, vol. 14, no. 1, pp. 218 – 227, Jan. 2014.
- [21] H. J. V. Tyrrell, *Diffusion in Liquids: A Theoretical and Experimental Study* (Monographs in Chemistry), Butterworth-Heinemann, 1984.

- [22] R. A. Freitas, *Nanomedicine, Vol. I: Basic Capabilities*, 1st edition, Landes Bioscience, 1999.
- [23] P. W. Rand, E. Lacombe, H. E. Hunt, and W. H. Austin, "Viscosity of normal human blood under normothermic and hypothermic conditions," *J Appl Physiol*, vol. 19, pp. 117-122, 1964.
- [24] K. R. Kensey and Y. I. Cho, *Physical principles and circulation: hemodynamics*. In: *The Origin of Atherosclerosis: What Really Initiates the Inflammatory Process*. 2nd ed. Summersville, WV: SegMedica, pp. 33-50, 2007.
- [25] S. Shin, S. W. Lee and Y. H. Ku, "Measurements of Blood viscosity using a pressure-scanning slit viscometer," vol. 18, no. 6, pp. 1036-1041, 2004.
- [26] H. J. Lim, Y. J. Lee, J. H. Nam, S. Chung, and S. Shin, "Temperature-dependent threshold shear stress of red blood cell aggregation," *Journal of Biomechanics*, vol. 43, no. 3, pp. 546-550, 2010.
- [27] M. Ş. Kuran, H. B. Yılmaz, T. Tugcu and B. Özerman, "Energy model for communication via diffusion in nanonetworks," *Nano Communication Networks*, vol. 1, no. 2, pp. 86-95, 2010.
- [28] I. Karatzas and S. E. Shreve, *Brownian Motion and Stochastic Calculus*, 2nd ed. New York: Springer, 1991.
- [29] <http://en.wikipedia.org/wiki/Hemorheology>; last accessed February 12, 2014.

[30]<http://ddbonline.ddbst.de/VogelCalculation/VogelCalculationCGI.exe?component=Water>; last accessed February 14, 2014.

## **APPENDICES**



## Appendix A: Water and Blood Viscosity Tables

**Table A.1** Water viscosity values with different temperatures

<b>Temperature (Kelvin)</b>	<b>Viscosity (kg/s.m)</b>
373	0.0002836
369	0.0002959
365	0.0003092
361	0.0003236
357	0.0003393
353	0.0003563
349	0.0003749
345	0.0003952
341	0.0004175
337	0.0004420
333	0.0004691
329	0.0004990
325	0.0005323
321	0.0005694
317	0.0006109
313	0.0006575
309	0.0007101
305	0.0007698
301	0.0008377
297	0.0009156
293	0.0010052
289	0.0011091
285	0.0012303
281	0.0013726
277	0.0015411
273	0.0017421

**Table A.2** Blood viscosity values at shear rate  $1\text{s}^{-1}$  with different temperatures

<b>Temperature (Kelvin)</b>	<b>Viscosity (kg/s.m)</b>
310	0.0365
309	0.03724
308	0.038
307	0.03872
306	0.03952
305	0.04033
304	0.04116
303	0.042
302	0.04272
301	0.04366
300	0.04456
299	0.04547
298	0.0464
297	0.04734
296	0.04831
295	0.0493
294	0.0503
293	0.05132
292	0.05237
291	0.05344
290	0.05454
289	0.05566
288	0.0568
287	0.058
286	0.05916
285	0.06037
284	0.06161
283	0.06287
282	0.06416
281	0.06547
280	0.06681
279	0.06818
278	0.06958
277	0.071

**Table A.3** Blood viscosity values at shear rate  $10\text{s}^{-1}$  with different temperatures

<b>Temperature (Kelvin)</b>	<b>Viscosity (kg/s.m)</b>
310	0.0131
309	0.01336
308	0.01362
307	0.01389
306	0.01416
305	0.01444
304	0.01472
303	0.01501
302	0.01531
301	0.01561
300	0.01592
299	0.01623
298	0.01655
297	0.01688
296	0.01721
295	0.01755
294	0.0179
293	0.01825
292	0.01861
291	0.01898
290	0.01935
289	0.01973
288	0.02012
287	0.02052
286	0.02093
285	0.02134
284	0.02176
283	0.02219
282	0.02263
281	0.02308
280	0.02354
279	0.02401
278	0.02449
277	0.02497

**Table A.4** Blood viscosity values at shear rate  $50\text{s}^{-1}$  with different temperatures

<b>Temperature (Kelvin)</b>	<b>Viscosity (kg/s.m)</b>
310	0.0051
309	0.0052
308	0.0053
307	0.0054
306	0.0055
305	0.00561
304	0.00572
303	0.00583
302	0.00594
301	0.00605
300	0.00617
299	0.0063
298	0.00642
297	0.00654
296	0.00667
295	0.0068
294	0.00693
293	0.00706
292	0.0072
291	0.00734
290	0.00748
289	0.00763
288	0.00778
287	0.00793
286	0.00808
285	0.00824
284	0.0084
283	0.00856
282	0.00873
281	0.0089
280	0.00907
279	0.00925
278	0.00943
277	0.00961

**Table A.5** Blood viscosity values at shear rate  $100\text{s}^{-1}$  with different temperatures

<b>Temperature (Kelvin)</b>	<b>Viscosity (kg/s.m)</b>
310	0.0041
309	0.00418
308	0.00426
307	0.00434
306	0.00442
305	0.0045
304	0.0046
303	0.0047
302	0.0048
301	0.0049
300	0.005
299	0.0051
298	0.0052
297	0.0053
296	0.0054
295	0.0055
294	0.00561
293	0.00572
292	0.00583
291	0.00594
290	0.00605
289	0.00617
288	0.0063
287	0.00642
286	0.00654
285	0.00667
284	0.0068
283	0.00693
282	0.00706
281	0.0072
280	0.00734
279	0.00748
278	0.00763
277	0.00778

**Table A.6** Blood viscosity values at shear rate  $1000\text{s}^{-1}$  with different temperatures

<b>Temperature (Kelvin)</b>	<b>Viscosity (kg/s.m)</b>
310	0.0031
309	0.00316
308	0.00322
307	0.00328
306	0.00334
305	0.0034
304	0.00346
303	0.00353
302	0.0036
301	0.00367
300	0.00374
299	0.00381
298	0.00388
297	0.00395
296	0.00403
295	0.00411
294	0.0042
293	0.00428
292	0.00436
291	0.00444
290	0.00452
289	0.00461
288	0.0047
287	0.0048
286	0.0049
285	0.005
284	0.0051
283	0.0052
282	0.0053
281	0.0054
280	0.0055
279	0.00561
278	0.00572
277	0.00583

## Appendix B: Source Codes For Numerical Results

- The PDF of the Latency in a Blood Medium for Different Distances

$d=\{1,2,4,8\}$ , and  $D=0.1$ :

```
t=0.1:10:100;  
f_t1=1./sqrt(1.256.*(t)).*exp(-1*((1^2)./(0.4.*(t))));  
f_t2=1./sqrt(1.256.*(t)).*exp(-1*((2^2)./(0.4.*(t))));  
f_t3=1./sqrt(1.256.*(t)).*exp(-1*((4^2)./(0.4.*(t))));  
f_t4=1./sqrt(1.256.*(t)).*exp(-1*((8^2)./(0.4.*(t))));  
plot(t,f_t1,t,f_t2,t,f_t3,t,f_t4)
```

- The PDF of the Latency in a Blood Medium with Drift Velocity

$v=\{0,0.1,0.2,0.4\}$  and  $d=4$ :

```
t=0.1:10:110;  
f_t1=1./sqrt(1.256.*(t)).*exp(-1*((4^2)./(0.4.*(t))));  
f_t2=1./sqrt(1.256.*(t)).*exp(-1*(((4-(0.1.*(t))).^2)./(0.4.*(t))));  
f_t3=1./sqrt(1.256.*(t)).*exp(-1*(((4-(0.2.*(t))).^2)./(0.4.*(t))));  
f_t4=1./sqrt(1.256.*(t)).*exp(-1*(((4-(0.4.*(t))).^2)./(0.4.*(t))));  
plot(t,f_t1,t,f_t2,t,f_t3,t,f_t4)
```

- PDF of the Latency in a Blood Medium with Different Shear Rates:

❖ For shear rate  $1s^{-1}$  for  $d=\{1,2,4,8\}$ :

- shear rate  $1s^{-1}$ ,  $T=310$  in  $Spm=Sfluid$ :

```
t=0.1:10:110;  
f_t1=1./sqrt(46.84.*(t)).*exp(-1*((1^2)./(14.92.*(t))));  
f_t2=1./sqrt(46.84.*(t)).*exp(-1*((2^2)./(14.92.*(t))));  
f_t3=1./sqrt(46.84.*(t)).*exp(-1*((4^2)./(14.92.*(t))));  
f_t4=1./sqrt(46.84.*(t)).*exp(-1*((8^2)./(14.92.*(t))));  
plot(t,f_t1,t,f_t2,t,f_t3,t,f_t4)
```

- shear rate  $1s^{-1}$ : T=310 in Spm>Sfluid:

```

t=0.1:10:110;
f_t1=1./sqrt(31.14.*(t)).*exp(-1*((1^2)./(9.92.*(t)));
f_t2=1./sqrt(31.14.*(t)).*exp(-1*((2^2)./(9.92.*(t)));
f_t3=1./sqrt(31.14.*(t)).*exp(-1*((4^2)./(9.92.*(t)));
f_t4=1./sqrt(31.14.*(t)).*exp(-1*((8^2)./(9.92.*(t)));
plot(t,f_t1,t,f_t2,t,f_t3,t,f_t4)

```
- shear rate  $1s^{-1}$ : T=277 in Spm=Sfluid:

```

t=0.1:10:110;
f_t1=1./sqrt(21.54.*(t)).*exp(-1*((1^2)./(6.86.*(t)));
f_t2=1./sqrt(21.54.*(t)).*exp(-1*((2^2)./(6.86.*(t)));
f_t3=1./sqrt(21.54.*(t)).*exp(-1*((4^2)./(6.86.*(t)));
f_t4=1./sqrt(21.54.*(t)).*exp(-1*((8^2)./(6.86.*(t)));
plot(t,f_t1,t,f_t2,t,f_t3,t,f_t4)

```
- shear rate  $1s^{-1}$ : T=277 in Spm>Sfluid:

```

t=0.1:10:110;
f_t1=1./sqrt(14.22.*(t)).*exp(-1*((1^2)./(4.52.*(t)));
f_t2=1./sqrt(14.22.*(t)).*exp(-1*((2^2)./(4.52.*(t)));
f_t3=1./sqrt(14.22.*(t)).*exp(-1*((4^2)./(4.52.*(t)));
f_t4=1./sqrt(14.22.*(t)).*exp(-1*((8^2)./(4.52.*(t)));
plot(t,f_t1,t,f_t2,t,f_t3,t,f_t4)

```



❖ For shear rate  $1000s^{-1}$  for  $d=\{1,2,4,8\}$ :

- shear rate  $1000s^{-1}$ : T=310 in Spm=Sfluid:

t=0.1:10:110;

f\_t1=1./sqrt(552.2.\*(t)).\*exp(-1\*((1^2)./(175.8.\*(t))));

f\_t2=1./sqrt(552.2.\*(t)).\*exp(-1\*((2^2)./(175.8.\*(t))));

f\_t3=1./sqrt(552.2.\*(t)).\*exp(-1\*((4^2)./(175.8.\*(t))));

f\_t4=1./sqrt(552.2.\*(t)).\*exp(-1\*((8^2)./(175.8.\*(t))));

plot(t,f\_t1,t,f\_t2,t,f\_t3,t,f\_t4)

- shear rate  $1000s^{-1}$ : T=310 in Spm>Sfluid:

t=0.1:10:110;

f\_t1=1./sqrt(364.4.\*(t)).\*exp(-1\*((1^2)./(116.\*(t))));

f\_t2=1./sqrt(364.4.\*(t)).\*exp(-1\*((2^2)./(116.\*(t))));

f\_t3=1./sqrt(364.4.\*(t)).\*exp(-1\*((4^2)./(116.\*(t))));

f\_t4=1./sqrt(364.4.\*(t)).\*exp(-1\*((8^2)./(116.\*(t))));

plot(t,f\_t1,t,f\_t2,t,f\_t3,t,f\_t4)

- shear rate  $1000s^{-1}$ : T=277 in Spm=Sfluid:

t=0.1:10:110;

f\_t1=1./sqrt(262.4.\*(t)).\*exp(-1\*((1^2)./(83.5.\*(t))));

f\_t2=1./sqrt(262.4.\*(t)).\*exp(-1\*((2^2)./(83.5.\*(t))));

f\_t3=1./sqrt(262.4.\*(t)).\*exp(-1\*((4^2)./(83.5.\*(t))));

f\_t4=1./sqrt(262.4.\*(t)).\*exp(-1\*((8^2)./(83.5.\*(t))));

plot(t,f\_t1,t,f\_t2,t,f\_t3,t,f\_t4)

- shear rate  $1000s^{-1}$ :  $T=277$  in  $Spm>Sfluid$ :

t=0.1:10:110;

f\_t1=1./sqrt(173.1.\*(t)).\*exp(-1\*((1^2)./(55.1.\*(t))));

f\_t2=1./sqrt(173.1.\*(t)).\*exp(-1\*((2^2)./(55.1.\*(t))));

f\_t3=1./sqrt(173.1.\*(t)).\*exp(-1\*((4^2)./(55.1.\*(t))));

f\_t4=1./sqrt(173.1.\*(t)).\*exp(-1\*((8^2)./(55.1.\*(t))));

plot(t,f\_t1,t,f\_t2,t,f\_t3,t,f\_t4)

➤ PDF of the Latency for Different Blood Shear Rates with Drift Velocity

v={0,0.1,0.2,0.4} and d=4:

❖ For shear rate  $1s^{-1}$ :

- T=310 in  $Spm=Sfluid$ :

t=0.1:10:110;

f\_t1=1./sqrt(46.84.\*(t)).\*exp(-1\*((4^2)./(14.92.\*(t))));

f\_t2=1./sqrt(46.84.\*(t)).\*exp(-1\*(((4-(0.1.\*t)).^2)./(14.92.\*(t))));

f\_t3=1./sqrt(46.84.\*(t)).\*exp(-1\*(((4-(0.2.\*t)).^2)./(14.92.\*(t))));

f\_t4=1./sqrt(46.84.\*(t)).\*exp(-1\*(((4-(0.4.\*t)).^2)./(14.92.\*(t))));

plot(t,f\_t1,t,f\_t2,t,f\_t3,t,f\_t4)

- T=310 in  $Spm>Sfluid$ :

t=0.1:10:110;

f\_t1=1./sqrt(31.14.\*(t)).\*exp(-1\*((4^2)./(9.92.\*(t))));

f\_t2=1./sqrt(31.14.\*(t)).\*exp(-1\*(((4-(0.1.\*t)).^2)./(9.92.\*(t))));

f\_t3=1./sqrt(31.14.\*(t)).\*exp(-1\*(((4-(0.2.\*t)).^2)./(9.92.\*(t))));

f\_t4=1./sqrt(31.14.\*(t)).\*exp(-1\*(((4-(0.4.\*t)).^2)./(9.92.\*(t))));

plot(t,f\_t1,t,f\_t2,t,f\_t3,t,f\_t4)

- T=277 in S<sub>pm</sub>=S<sub>fluid</sub>:

```
t=0.1:10:110;
f_t1=1./sqrt(21.54.*(t)).*exp(-1*((4^2)./(6.86.*(t)));
f_t2=1./sqrt(21.54.*(t)).*exp(-1*(((4-(0.1.*t)).^2)./(6.86.*(t)));
f_t3=1./sqrt(21.54.*(t)).*exp(-1*(((4-(0.2.*t)).^2)./(6.86.*(t)));
f_t4=1./sqrt(21.54.*(t)).*exp(-1*(((4-(0.4.*t)).^2)./(6.86.*(t)));
plot(t,f_t1,t,f_t2,t,f_t3,t,f_t4)
```

- T=277 in S<sub>pm</sub>>S<sub>fluid</sub>:

```
t=0.1:10:110;
f_t1=1./sqrt(14.22.*(t)).*exp(-1*((4^2)./(4.52.*(t)));
f_t2=1./sqrt(14.22.*(t)).*exp(-1*(((4-(0.1.*t)).^2)./(4.52.*(t)));
f_t3=1./sqrt(14.22.*(t)).*exp(-1*(((4-(0.2.*t)).^2)./(4.52.*(t)));
f_t4=1./sqrt(14.22.*(t)).*exp(-1*(((4-(0.4.*t)).^2)./(4.52.*(t)));
plot(t,f_t1,t,f_t2,t,f_t3,t,f_t4)
```

❖ For shear rate 1000s<sup>-1</sup>:

- T=310 in S<sub>pm</sub>=S<sub>fluid</sub>:

```
t=0.1:10:110;
f_t1=1./sqrt(552.2.*(t)).*exp(-1*((4^2)./(175.8.*(t)));
f_t2=1./sqrt(552.2.*(t)).*exp(-1*(((4-(0.1.*t)).^2)./(175.8.*(t)));
f_t3=1./sqrt(552.2.*(t)).*exp(-1*(((4-(0.2.*t)).^2)./(175.8.*(t)));
f_t4=1./sqrt(552.2.*(t)).*exp(-1*(((4-(0.4.*t)).^2)./(175.8.*(t)));
plot(t,f_t1,t,f_t2,t,f_t3,t,f_t4)
```

- T=310 in Spm>Sfluid:

```
t=0.1:10:110;
f_t1=1./sqrt(364.4.*(t)).*exp(-1*((4^2)./(116.*(t)));
f_t2=1./sqrt(364.4.*(t)).*exp(-1*(((4-(0.1.*t)).^2)./(116.*(t)));
f_t3=1./sqrt(364.4.*(t)).*exp(-1*(((4-(0.2.*t)).^2)./(116.*(t)));
f_t4=1./sqrt(364.4.*(t)).*exp(-1*(((4-(0.4.*t)).^2)./(116.*(t)));
plot(t,f_t1,t,f_t2,t,f_t3,t,f_t4)
```

- T=277 in Spm=Sfluid:

```
t=0.1:10:110;
f_t1=1./sqrt(262.4.*(t)).*exp(-1*((4^2)./(83.5.*(t)));
f_t2=1./sqrt(262.4.*(t)).*exp(-1*(((4-(0.1.*t)).^2)./(83.5.*(t)));
f_t3=1./sqrt(262.4.*(t)).*exp(-1*(((4-(0.2.*t)).^2)./(83.5.*(t)));
f_t4=1./sqrt(262.4.*(t)).*exp(-1*(((4-(0.4.*t)).^2)./(83.5.*(t)));
plot(t,f_t1,t,f_t2,t,f_t3,t,f_t4)
```

- T=277 in Spm>Sfluid:

```
t=0.1:10:110;
f_t1=1./sqrt(173.1.*(t)).*exp(-1*((4^2)./(55.1.*(t)));
f_t2=1./sqrt(173.1.*(t)).*exp(-1*(((4-(0.1.*t)).^2)./(55.1.*(t)));
f_t3=1./sqrt(173.1.*(t)).*exp(-1*(((4-(0.2.*t)).^2)./(55.1.*(t)));
f_t4=1./sqrt(173.1.*(t)).*exp(-1*(((4-(0.4.*t)).^2)./(55.1.*(t)));
plot(t,f_t1,t,f_t2,t,f_t3,t,f_t4)
```

➤ Comparison of Different Blood Shear Rates:

- T=310 K in S<sub>pm</sub>=S<sub>fluid</sub> for d=1;

t=0.1:10:110;

f\_t1=1./sqrt(46.84.\*(t)).\*exp(-1\*((1^2)./(14.92.\*(t))));

f\_t2=1./sqrt(130.7.\*(t)).\*exp(-1\*((1^2)./(41.62.\*(t))));

f\_t3=1./sqrt(335.7.\*(t)).\*exp(-1\*((1^2)./(107.\*(t))));

f\_t4=1./sqrt(417.5.\*(t)).\*exp(-1\*((1^2)./(133.\*(t))));

f\_t5=1./sqrt(552.2.\*(t)).\*exp(-1\*((1^2)./(175.8.\*(t))));

plot(t,f\_t1,t,f\_t2,t,f\_t3,t,f\_t4,t,f\_t5)

- T=310 K in S<sub>pm</sub>=S<sub>fluid</sub> for d=8;

t=0.1:10:110;

f\_t1=1./sqrt(46.84.\*(t)).\*exp(-1\*((8^2)./(14.92.\*(t))));

f\_t2=1./sqrt(130.7.\*(t)).\*exp(-1\*((8^2)./(41.62.\*(t))));

f\_t3=1./sqrt(335.7.\*(t)).\*exp(-1\*((8^2)./(107.\*(t))));

f\_t4=1./sqrt(417.5.\*(t)).\*exp(-1\*((8^2)./(133.\*(t))));

f\_t5=1./sqrt(552.2.\*(t)).\*exp(-1\*((8^2)./(175.8.\*(t))));

plot(t,f\_t1,t,f\_t2,t,f\_t3,t,f\_t4,t,f\_t5)

- T=310 K in S<sub>pm</sub>>S<sub>fluid</sub> for d=1;

t=0.1:10:110;

f\_t1=1./sqrt(31.14.\*(t)).\*exp(-1\*((1^2)./(9.92.\*(t))));

f\_t2=1./sqrt(86.26.\*(t)).\*exp(-1\*((1^2)./(27.47.\*(t))));

f\_t3=1./sqrt(221.5.\*(t)).\*exp(-1\*((1^2)./(70.5.\*(t))));

f\_t4=1./sqrt(275.5.\*(t)).\*exp(-1\*((1^2)./(87.7.\*(t))));

f\_t5=1./sqrt(364.4.\*(t)).\*exp(-1\*((1^2)./(116.\*(t))));

plot(t,f\_t1,t,f\_t2,t,f\_t3,t,f\_t4,t,f\_t5)

- T=310 K in Spm>Sfluid for d=8;  
t=0.1:10:110;  
f\_t1=1./sqrt(31.14.\*(t)).\*exp(-1\*((8^2)./(9.92.\*(t)));  
f\_t2=1./sqrt(86.26.\*(t)).\*exp(-1\*((8^2)./(27.47.\*(t)));  
f\_t3=1./sqrt(221.5.\*(t)).\*exp(-1\*((8^2)./(70.5.\*(t)));  
f\_t4=1./sqrt(275.5.\*(t)).\*exp(-1\*((8^2)./(87.7.\*(t)));  
f\_t5=1./sqrt(364.4.\*(t)).\*exp(-1\*((8^2)./(116.\*(t)));  
plot(t,f\_t1,t,f\_t2,t,f\_t3,t,f\_t4,t,f\_t5)
  
- T=277 K in Spm=Sfluid for d=1;  
t=0.1:10:110;  
f\_t1=1./sqrt(21.54.\*(t)).\*exp(-1\*((1^2)./(6.86.\*(t)));  
f\_t2=1./sqrt(61.2.\*(t)).\*exp(-1\*((1^2)./(19.5.\*(t)));  
f\_t3=1./sqrt(159.3.\*(t)).\*exp(-1\*((1^2)./(50.7.\*(t)));  
f\_t4=1./sqrt(196.6.\*(t)).\*exp(-1\*((1^2)./(62.6.\*(t)));  
f\_t5=1./sqrt(262.4.\*(t)).\*exp(-1\*((1^2)./(83.5.\*(t)));  
plot(t,f\_t1,t,f\_t2,t,f\_t3,t,f\_t4,t,f\_t5)
  
- T=277 K in Spm=Sfluid for d=8;  
t=0.1:10:110;  
f\_t1=1./sqrt(21.54.\*(t)).\*exp(-1\*((8^2)./(6.86.\*(t)));  
f\_t2=1./sqrt(61.2.\*(t)).\*exp(-1\*((8^2)./(19.5.\*(t)));  
f\_t3=1./sqrt(159.3.\*(t)).\*exp(-1\*((8^2)./(50.7.\*(t)));  
f\_t4=1./sqrt(196.6.\*(t)).\*exp(-1\*((8^2)./(62.6.\*(t)));  
f\_t5=1./sqrt(262.4.\*(t)).\*exp(-1\*((8^2)./(83.5.\*(t)));  
plot(t,f\_t1,t,f\_t2,t,f\_t3,t,f\_t4,t,f\_t5)

- T=277 K in Spm>Sfluid for d=1;  
t=0.1:10:110;  
f\_t1=1./sqrt(14.36.\*(t)).\*exp(-1\*((1^2)./(4.57.\*(t)));  
f\_t2=1./sqrt(40.3.\*(t)).\*exp(-1\*((1^2)./(12.8.\*(t)));  
f\_t3=1./sqrt(105.\*(t)).\*exp(-1\*((1^2)./(33.4.\*(t)));  
f\_t4=1./sqrt(130.\*(t)).\*exp(-1\*((1^2)./(41.3.\*(t)));  
f\_t5=1./sqrt(173.1.\*(t)).\*exp(-1\*((1^2)./(55.1.\*(t)));  
plot(t,f\_t1,t,f\_t2,t,f\_t3,t,f\_t4,t,f\_t5)
  
- T=277 K in Spm>Sfluid for d=8;  
t=0.1:10:110;  
f\_t1=1./sqrt(14.36.\*(t)).\*exp(-1\*((8^2)./(4.57.\*(t)));  
f\_t2=1./sqrt(40.3.\*(t)).\*exp(-1\*((8^2)./(12.8.\*(t)));  
f\_t3=1./sqrt(105.\*(t)).\*exp(-1\*((8^2)./(33.4.\*(t)));  
f\_t4=1./sqrt(130.\*(t)).\*exp(-1\*((8^2)./(41.3.\*(t)));  
f\_t5=1./sqrt(173.1.\*(t)).\*exp(-1\*((8^2)./(55.1.\*(t)));  
plot(t,f\_t1,t,f\_t2,t,f\_t3,t,f\_t4,t,f\_t5)

➤ The PDF of the Latency in a Water Medium:

- T=273 (K) in Spm>Sfluid for different distances:  
t=0.1:10:110;  
f\_t1=1./sqrt(577.\*(t)).\*exp(-1\*((1^2)./(183.76.\*(t)));  
f\_t2=1./sqrt(577.\*(t)).\*exp(-1\*((2^2)./(183.76.\*(t)));  
f\_t3=1./sqrt(577.\*(t)).\*exp(-1\*((4^2)./(183.76.\*(t)));  
f\_t4=1./sqrt(577.\*(t)).\*exp(-1\*((8^2)./(183.76.\*(t)));  
plot(t,f\_t1,t,f\_t2,t,f\_t3,t,f\_t4)

- T=373 (K) in Spm>Sfluid for different distances:

t=0.1:10:110;

f\_t1=1./sqrt(4842.5.\*(t)).\*exp(-1\*((1^2)./(1542.2.\*(t))));

f\_t2=1./sqrt(4842.5.\*(t)).\*exp(-1\*((2^2)./(1542.2.\*(t))));

f\_t3=1./sqrt(4842.5.\*(t)).\*exp(-1\*((4^2)./(1542.2.\*(t))));

f\_t4=1./sqrt(4842.5.\*(t)).\*exp(-1\*((8^2)./(1542.2.\*(t))));

plot(t,f\_t1,t,f\_t2,t,f\_t3,t,f\_t4)

- T=273 (K), d=1, and Spm>Sfluid for different velocities:

t=0.1:10:110;

f\_t1=1./sqrt(577.\*(t)).\*exp(-1\*((1^2)./(183.76.\*(t))));

f\_t2=1./sqrt(577.\*(t)).\*exp(-1\*(((1-(0.1.\*t)).^2)./(183.76.\*(t))));

f\_t3=1./sqrt(577.\*(t)).\*exp(-1\*(((1-(0.2.\*t)).^2)./(183.76.\*(t))));

f\_t4=1./sqrt(577.\*(t)).\*exp(-1\*(((1-(0.4.\*t)).^2)./(183.76.\*(t))));

plot(t,f\_t1,t,f\_t2,t,f\_t3,t,f\_t4)

- Comparison of Different Temperatures in Spm>Sfluid and d=1(μm):

t=0.1:10:110;

f\_t1=1./sqrt(577.\*(t)).\*exp(-1\*((1^2)./(183.76.\*(t))));

f\_t2=1./sqrt(2248.\*(t)).\*exp(-1\*((1^2)./(716.\*(t))));

f\_t3=1./sqrt(4842.5.\*(t)).\*exp(-1\*((1^2)./(1542.2.\*(t))));

plot(t,f\_t1,t,f\_t2,t,f\_t3)

- Comparison of Different Temperatures in Spm>Sfluid and d=8(μm):

t=0.1:10:110;

f\_t1=1./sqrt(577.\*(t)).\*exp(-1\*((8^2)./(183.76.\*(t))));

f\_t2=1./sqrt(2248.\*(t)).\*exp(-1\*((8^2)./(716.\*(t))));

f\_t3=1./sqrt(4842.5.\*(t)).\*exp(-1\*((8^2)./(1542.2.\*(t))));

plot(t,f\_t1,t,f\_t2,t,f\_t3)