

# **Green Building Concept of Residential Housing in Lebanon**

**Hani El Fawal**

Submitted to the  
Institute of Graduate Studies and Research  
in partial fulfilment of the requirements for the degree of

Master of Science  
in  
Civil Engineering

Eastern Mediterranean University  
February 2015  
Gazimağusa, North Cyprus

Approval of the Institute of Graduate Studies and Research

---

Prof. Dr. Serhan Çiftçiođlu  
Acting Director

I certify that this thesis satisfies the requirements as a thesis for the degree of Master of Science in Civil Engineering.

---

Prof. Dr. Özgür Eren  
Chair, Department of Civil Engineering

We certify that we have read this thesis and that in our opinion it is fully adequate in scope and quality as a thesis for the degree of Master of Science in Civil Engineering.

---

Asst. Prof. Dr. Mürüde Çelikađ  
Supervisor

---

Examining Committee

1. Assoc. Prof. Dr. İbrahim Yitmen

---

2. Asst.Prof. Dr. Tülin Akçaođlu

---

3. Asst. Prof. Dr. Mürüde Çelikađ

---

## ABSTRACT

Recent years has seen a gradual increase of interest in green buildings due to their many advantages and positive effect on the environment, economy and our lifestyle. Hence, for achieving more benefits from green buildings, there is more research into this subject in order to further improve this concept. In addition to incentives provided for building green in developed countries like United States and United Kingdom, with the support of non-government organizations assessments based on green certification programs, such as, BREEAM and LEED has been established. On the other hand, countries like Lebanon are still unable to implement green buildings in an efficient manner. The purpose of this study is to discuss the importance of green building concepts for residential buildings and investigate the situation in Lebanon. For this reason, a survey was conducted targeting the Lebanese general public and professionals for better understanding of their knowledge and awareness regarding green buildings. The residential building Factory 4376 is located near the Lebanese capital city of Beirut. It is the case study that was evaluated by using the BREEAM certification categories and as a result it was promoted to BREEAM "GOOD" classification, ranging from 45% to 55%. The survey results are presented through which the problems affecting the development of green buildings in Lebanon are identified. Thus, it is expected that this study will contribute towards understanding matters relating to sustainable development in general and green residential buildings in particular.

**Keywords:** green building in Lebanon, BREEAM, LEED, green products, Lebanese market.

## ÖZ

Son yıllarda bu binaların çevre, ekonomi ve yaşam tarzımıza etki eden birçok avantaj ve pozitif etkilerinden dolayı yeşil binalara karşı ilgi kademeli olarak artmıştır. Bundan dolayı, yeşil binalardan daha çok faydalanabilmek için bu konuyla ilgili kavramları daha çok geliştirme adına daha çok araştırmalar yapılmaktadır. Amerika Birleşik Devletleri ve İngiltere gibi gelişmiş ülkelerde devletin verdiği teşviklere ilaveten sivil toplum örgütlerinin desteğiyle BREEAM ve LEED gibi yeşil sertifika programları başlatılmıştır. Diğer yandan, Lübnan gibi ülkeler halen yeşil binaları etkin bir şekilde uygulayamamaktadırlar. Bu çalışmanın amacı meskun binalar için yeşil bina konseptinin önemini tartışmak ve Lubnan'daki durumu araştırmaktır. Bu nedenle, Lubnanlı genel halk ve profesyonellerin yeşil binalarla ilgili bilgi ve farkındalığını ölçecek bir anket hazırlanmıştır. Meskun bina Factory 4376 Lubnan'ın baş kenti Beyrut yakınlarındadır. Bu bina örnek olay olarak BREEAM serifika programı kullanılarak değerlendirilmiş ve %45 ile %55 arasında toplanılan puanlarla BREEAM 'İYİ' sınıflandırması almıştır. Anket sonuçları kullanılarak Lubnan'da yeşil bina konseptini etkileyen problemler tespit edildi. Böylece, bu çalışmanın genelde sürdürülebilir kalkınma ve özelde de yeşil meskun binaların daha iyi anlaşılması için katkı koyması beklenmektedir.

**Anahtar Kelimeler:** Lubnan'da yeşil bina, BREEAM, LEED, yeşil ürünler, Lübnan pazarı.

## ACKNOWLEDGMENT

First of all, I owe my deepest appreciation to my supervisor Asst. Prof. Dr. Mürüde Çelikağ, who stood by me since the beginning till the end of this thesis, and I wouldn't be able to complete and understand the process of this dissertation without her supervision and encouragement.

I also would like to thank Assoc. Prof. Dr. Zalihe Nanbantoglu for her support at the beginning of this thesis and guiding me in the seminar where I had a clearer view of the topic.

I am grateful to the whole department of Civil Engineering at Eastern Mediterranean University for not letting me feel that I was away from my country, family and home during the year I spent studying the courses for my master's degree.

Finally, I wouldn't be able to achieve and finish this thesis without the support of my family, especially my father who supported me by all means so that I would complete this year without facing any problem.

# TABLE OF CONTENTS

ABSTRACT .....	iii
ÖZ .....	iv
ACKNOWLEDGMENT .....	v
LIST OF TABLES .....	x
LIST OF FIGURES .....	xi
1 INTRODUCTION .....	1
1.1 General Introduction.....	1
1.2 Objective of Research .....	3
1.3 Outline of Thesis .....	4
2 GREEN BUILDING CONCEPTS.....	5
2.1 Green Roofs.....	6
2.1.1 Introduction.....	6
2.1.2 Energy Saving.....	8
2.1.3 Heat Island Effect Reduction.....	8
2.1.4 Reducing Air Pollution .....	9
2.1.5 Reducing Storm Water Runoff .....	9
2.1.6 Aesthetics.....	9
2.1.7 Extensive versus Intensive.....	9
2.1.8 Green Roof Design and Maintenance.....	10
2.2 Sustainable Drainage .....	11
2.2.1 Introduction.....	11
2.2.2 Sustainable Drainage in Rural Areas .....	11
2.2.3 Sustainable Drainage in Urban Areas.....	12

2.3 Rain and Grey Water .....	13
2.3.1 Rain Water Harvesting .....	14
2.3.2 Grey Water Recycling .....	15
2.4 Sustainable Transportation .....	16
2.4.1 Introduction.....	16
2.4.2 Walking and Cycling .....	17
2.4.2 Public Transportation.....	18
2.4.3 Cutting Distances.....	18
2.5 Cementitious Materials.....	21
2.5.1 Energy Saving and Reduced CO <sub>2</sub> Emissions.....	21
2.5.2 Technical Benefits .....	22
2.5.3 Modern Applications .....	23
2.6 Construction Waste .....	24
2.7 Solar Energy .....	26
2.7.1 Introduction.....	26
2.7.2 Solar Energy Applications .....	28
2.7.3 Solar Energy Economy .....	30
3 GREEN BUILDINGS IN LEBANON.....	31
3.1 Introduction .....	31
3.2 Green Buildings in Lebanon.....	33
3.4 BREEAM Certification .....	36
3.4.1 Introduction.....	36
3.4.2 Features of BREEAM.....	37
3.4.3 The Principles of BREEAM .....	38
3.4.4 The BREEAM Assessment Process .....	38

3.4.5 The Structure of a BREEAM Assessment.....	40
3.4.6 Calculation of Building’s BREEAM Rating .....	40
3.5 Arz Certification.....	42
4 CASE STUDY: FACTORY 4376 RESIDENTIAL BUILDING.....	43
4.1 Introduction .....	43
4.2 Design Overview .....	44
4.3 Management .....	45
4.3.1 Preliminary Design .....	45
4.3.2 Construction Phase .....	46
4.4 Health and Wellbeing.....	47
4.5 Energy and Water Efficiency .....	50
4.5.1 Efficient Equipment.....	50
4.5.2 LED vs. Fluorescent Lighting.....	52
4.5.3 Efficient Systems .....	54
4.5.4 Water Heating Solar Panels .....	56
4.5.5 Thermal Insulation.....	57
4.6 Transportation .....	58
4.7 Materials .....	59
4.8 BREEAM vs. LEED.....	61
4.9 Analysis and Discussions .....	63
5 SURVEY ANALYSIS, RESULTS AND DISCUSSIONS .....	65
5.2 Results and Analysis .....	66
5.2.1 Question 1 .....	66
5.2.2 Question 2.....	66
5.2.3 Question 3.....	67



5.2.4 Question 4.....	67
5.2.5 Question 5.....	68
5.2.6 Question 6.....	68
5.2.7 Question 7.....	69
5.2.8 Question 8-9.....	70
5.2.9 Question 10.....	70
5.2.10 Question 11.....	71
5.2.11 Question 12.....	71
5.2.12 Question 13.....	72
5.2.13 Question 14.....	72
5.2.14 Question 15.....	73
5.2.15 Question 16.....	74
5.2.16 Question 17.....	74
5.2.17 Question 18.....	75
5.2.18 Question 19.....	75
5.3 Discussion of Survey Results.....	76
<b>6 CONCLUSION AND RECOMMENDATIONS.....</b>	<b>77</b>
6.1 Conclusion.....	77
6.2 Recommendations.....	78
6.3 Recommendations for future study:.....	79
<b>REFERENCES.....</b>	<b>80</b>
<b>APPENDICES.....</b>	<b>86</b>
Appendix A: Questionnaires.....	87
Appendix B: Tables of Survey.....	89

## LIST OF TABLES

Table 3.2: Environmental Sections Weighting [41].....	41
Table 3.3: Rating of BREEAM [41] .....	41
Table 4.1: LED vs. Fluorescent - Material Cost .....	53
Table 4.2: LED vs. Fluorescent - Energy Cost .....	53
Table 4.3: Comparison of the weakness and strength of LEED and BREEAM.....	61
Table 4.4: Percentage for each topic by LEED and BREEAM.....	62
Table 4.5: Management Category.....	63
Table 4.6: Transportation Category.....	63
Table 4.7: Health Category.....	64
Table 4.8: Energy and Water Categories.....	64
Table 5.1: Specimen Distribution.....	65

## LIST OF FIGURES

Figure 2.1: Extensive Green Roofs Layers [3] .....	6
Figure 2.2: Extensive Green Roof [5].....	7
Figure 2.3: Intensive Green Roof [6].....	7
Figure 2.4: City Full of Green Roofs [8] .....	9
Figure 2.5: Wet Pond [11].....	12
Figure 2.6: Concrete Blocks Permeable Pavement [9] .....	13
Figure 2.7: Rainwater Harvesting System [13].....	15
Figure 2.8: Sustainable Transportation [16] .....	16
Figure 2.9: Livable Streets [18] .....	17
Figure 3.1: Abandoned Railways in Tripoli-Lebanon [35].....	32
Figure 3.2: Cement Process Plant in Chekka-Lebanon [36].....	33
Figure 3.3: Beirut River Solar Snake [37] .....	34
Figure 3.4: Beirut City Centre [38].....	35
Figure 3.5: Beirut Terraces [38].....	36
Figure 3.6: Assessment Process [41].....	39
Figure 4.1: Factory 4376 Architectural 3-D view [42] .....	43
Figure 4.2: Sustainable Design [43].....	45
Figure 5.1: Question 1-Gender Bar Chart.....	66
Figure 5.2: Question 1-Age Group Bar Chart.....	66
Figure 5.3: Question 2-Gender Pie Chart.....	66
Figure 5.4: Question 2-Education Pie Chart .....	66
Figure 5.5: Question 3-Nationality Bar Chart.....	66
Figure 5.6: Question 3-Age Group Bar Chart.....	66

Figure 5.7: Question 4-Nationality Bar Chart.....	66
Figure 5.8: Question 4-Age Group Bar Chart.....	66
Figure 5.9: Question 5-Gender Bar Chart.....	66
Figure 5.10: Question 5-Age Group Bar Chart.....	66
Figure 5.11: Question 6-Education Pie Chart .....	66
Figure 5.12: Question 7-Gender Bar Chart.....	66
Figure 5.13: Question 7-Age Group Bar Chart.....	66
Figure 5.14: Question 9-Education Bar Chart .....	70
Figure 5.15: Question 9-Age Group Bar Chart.....	70
Figure 5.16: Question 10-Education Bar Chart .....	71
Figure 5.17: Question 10-Age Group Bar Chart.....	71
Figure 5.18: Question 11-Education Bar Chart .....	71
Figure 5.19: Question 11-Status Bar Chart.....	71
Figure 5.20: Question 12-Education Pie Chart .....	72
Figure 5.21: Question 13 Gender Bar Chart .....	72
Figure 5.22: Question 13- Age Group Bar Chart.....	72
Figure 5.23: Question 14-Education Bar Chart .....	73
Figure 5.24: Question 15-Education Bar Chart .....	73
Figure 5.25: Question 15-Status Bar Chart.....	73
Figure 5.26: Question 16-Gender Bar Chart.....	74
Figure 5.27: Question 16-Education Bar Chart .....	74
Figure 5.28: Question 17-Education Pie Chart .....	75
Figure 5.29: Question 18-Education Bar Chart .....	75
Figure 5.30: Question 18-Status Bar Chart.....	75
Figure 5.31: Question 19-Gender Bar Chart.....	76

# Chapter 1

## INTRODUCTION

### 1.1 General Introduction

The pollution of our planet has evolved dramatically since the beginning of the industrial revolution. Nowadays, our earth is suffering from severe problems including deforestation, global warming related to the high CO<sub>2</sub> emissions, toxic waste and depletion of natural resources. The danger levels for these chronic problems are becoming more and more critical as lives of plants and animals and even human beings are threatened or at least negatively affected [1].

As the pollution has reached at a level where the public health and entire world economy and future are at stake, governments and public started to feel the growing dangers. Therefore many initiatives have been taken to avoid further damage to the environment. World political leaders have gathered on many international events to discuss methods and form strategies towards reducing pollution. On the other hand scientists and Non-Governmental Organisations (NGO) have started to raise awareness of public to facilitate the formation and application of innovative solutions to solve the pollution problems.

From the construction point of view, traditional buildings that use reinforced concrete and mortar consisting of cement, sand and water have been causing some damages to the environment. Green areas are constantly being reduced due to the

spreading of mega cities around the world. Buildings alone are responsible for the consumption of one sixth of freshwater and one quarter of wood and energy flow. On the other hand, production of construction materials has a significant effect on the environment. For example the cement production is estimated to be responsible of about 5% of the total manmade CO<sub>2</sub> emissions worldwide.

Sustainable or green buildings can contribute greatly towards solving the above mentioned problems. Green buildings are known to have many benefits like reducing the energy and water consumption, improving air quality and the aesthetics of the building, providing thermal insulation, reducing noise, recycling materials and encouraging wildlife [1].

Sustainable building design should be done in an organised manner. It should respect international codes and requirements in order to be classified as a green building. There are two main green building rating systems in the world which offer official sustainable buildings certifications: LEED (Leadership in Energy & Environmental Design) developed by the U.S. Green Building Council (USGBC) in the United States and BREEAM (Building Research Establishment Environmental Assessment Methodology) developed by the BRE (Building Research Establishment) in the United Kingdom [1].

Many people believe that adopting the concept of green building is very important due to its benefits. Yet when it comes to economy, green buildings may reduce the indirect cost on the inhabitants and the society in general. But one should keep in mind the direct cost too.

The past experience indicates direct costs related to the initial expenses of the green buildings compared to the traditional ones due to the methods and materials used in this type of construction. Therefore, the design of green building should be well prepared and studied before the construction process.

Sustainable buildings have considerable support in develop countries, such as, United States and those in Europe. Governments in these countries and other private organisations support and provide initiatives for design and construction of green buildings. On the other hand, this type of support and initiatives are missing in other countries like Lebanon where companies rely on international loans and face numerous difficulties with regards to green building construction.

## **1.2 Objective of Research**

The objective of this research is to discuss the general conditions of sustainable buildings projects, supporting organizations and availability of materials in the country. This is done through providing different features and concepts of sustainable buildings in general, and the status of such concepts in Lebanon The answers of professional towards designing green buildings, availability of sustainable materials are also investigated and presented.

A case study featuring a 10-storey residential building named “Factory 4376” which is located at the edge of the Lebanese Capital city of Beirut is investigated. The study consists of an initial evaluation of the building based on the BREEAM specifications and it details the conditions affecting the use of such systems, including the political situation in Lebanon.

Also a survey reflecting the public opinion and professionals in Lebanon was conducted. The survey's analysis results along with the findings from case study provide adequate information about the status of green building approach for residential building in Lebanon.

### **1.3 Outline of Thesis**

- Introduction about the green building concepts and objective of the research are given in chapter 1.
- Chapter 2 includes a literature review about sustainability features.
- Chapter 3 gives the methodology of the study.
- Chapter 4 provides the details of the case study on "Factory 4376".
- Chapter 5 delivers the results analysis and discussions of the questionnaire distributed to Lebanese citizens.
- An overall conclusion of this research is given in chapter 6



## **Chapter 2**

### **GREEN BUILDING CONCEPTS**

In order to understand the green building concepts, one must first understand the main purposes of green or sustainable buildings.

A sustainable building is an eco-friendly building meeting many criteria concerning aesthetic appearance, water and energy consumption, improvement of air quality and thermal insulation, reduction of noise, equipped for an efficient drainage and transportation, the use of certain types of nontoxic and sustainable materials, and other applications.

Yet, another aspect of sustainability is the efficiency and the durability which requires a balanced budget for the construction of any project. Therefore, there should always be a certain balance between the expenses and the green features in any project.

This section will discuss the following concepts in green buildings:

- Green Roofs
- Sustainable Drainage
- Rain and Grey Water
- Sustainable Transportation
- Cementitious Materials

- Construction Waste
- Solar Energy

## 2.1 Green Roofs

### 2.1.1 Introduction

Green roofs have many benefits for the environment. They are considered to be an increasingly used sustainable concept especially in large cities. Green roofs replace traditional flat roofs and are mainly made of a root barrier, drainage, filter, growing medium, and a vegetation layer (Figure 2.1) [2].



Figure 2.1: Extensive Green Roofs Layers [3]

Many factors influence the green roof efficiency and cost. Therefore, the designer should conduct a delicate analysis to account for both and choose the best option. Green buildings are mainly divided into intensive and extensive. Also a third type of green roofs exist which is the semi-intensive green roof. While extensive green roofs, as shown in Figure 2.2 require shallow planting medium, intensive green roofs

require a deep medium usually greater than 1 foot and can reach up to 3 feet as shown in Figure 2.3 [4]. Each type has its own characteristics regarding its benefits, disadvantages and cost.



Figure 2.2: Extensive Green Roof [5]



Figure 2.3: Intensive Green Roof [6]

Green roofs are effective in the following features.

### **2.1.2 Energy Saving**

By providing a better thermal insulation compared with the traditional flat roofs, green roofs help reduce the amount of energy needed for both heating and cooling. Note that this benefit is more effective in the case of intensive green roofs [4].

In Lebanon one-third of energy is consumed by house and water heating for residential use. The application of adequate insulation to various parts of a building would lead to a reduction of 12% in energy consumption for heating. In addition, the use of programmable thermostat for boilers instead of conventional one can also save around 20% energy [7].

### **2.1.3 Heat Island Effect Reduction**

The heat island effect is a phenomenon which occurs in dense urban areas where the traditional dark roofs absorb the solar radiation which increases the temperature of the city as shown in Figure 2.4 [2].

Green roofs absorb less heat than normal roofs. Also vegetation goes through a phenomenon called perspiration which is a phenomenon that cools down the air around the plants [2]. Yet in order to be more effective, green roofs should be widely spread in the city.



Figure 2.4: City Full of Green Roofs [8]

#### **2.1.4 Reducing Air Pollution**

This reduction of air pollution is due to the photosynthesis phenomenon which takes carbon dioxide  $\text{CO}_2$  and transforms it into oxygen. On the other hand, reducing the energy demand as discussed earlier shall also have a positive effect by reducing the pollutants coming out of the power plants [4].

#### **2.1.5 Reducing Storm Water Runoff**

The reduction of storm water runoff is done by the absorption of green roof. It shall absorb water until full saturation and the remaining water is placed using an appropriate drainage system through the drainage layer in the green roof [2].

#### **2.1.6 Aesthetics**

Green roofs provide a beautiful and appealing view to the building since they are full of artistic shapes and colors. If used in large quantities, green roofs may change the whole shape of our cities.

#### **2.1.7 Extensive versus Intensive**

As mentioned earlier, intensive green roofs usually have a better capacity than extensive green roofs therefore, they shall provide more benefits. Moreover, the type

of plantation used in intensive green roofs allows the creation of a roof garden which can be a great gathering place for the inhabitants.

On the other hand, the designer should be careful that intensive green roofs are far more expensive, require a lot of maintenance and impose additional structural design requirements due to its heavy weight. This is why the designers only settle for extensive green roofs in many cases depending on the requirements of the project.

In many cases, intensive green roofs cannot be applied on old buildings due to its significant load while extensive green roofs on the other hand may be applied in many of these cases.

#### **2.1.8 Green Roof Design and Maintenance**

Many requirements should be met when designing a green roof. First, the designer should set the goals of his design. Based on his needs, the designer shall choose the type of the green building.

The design should take care of the types of materials and vegetation that can be used, access of the roof, safety measurements during and after construction, drainage system, watering system and structural design.

After construction, green roofs should be under periodic maintenance. Usually green roof materials have a limited durability and they need to be replaced periodically.

## **2.2 Sustainable Drainage**

### **2.2.1 Introduction**

Sustainable drainage systems rely on simple methods that imitate the environment in order to control storm runoffs [9].

This has been causing many problems especially in urban areas where the spreading of impermeable concrete has reduced the land's capacity to absorb the water [10]. Traditional drainage systems like traditional inlets and sewers have failed in many cases to limit the floods caused by storm runoffs [10].

### **2.2.2 Sustainable Drainage in Rural Areas**

The sustainable drainage systems' main objective is to collect and clean the water using the least amount of resources. Those systems are best applicable on surface water runoff which is relatively easy to clean. In this section, the latest and most effective methods regarding the sustainable drainage systems shall be discussed.

In rural areas, spaces are available to create artificial wetlands or ponds. Therefore the runoff water is collected through piping systems and disposed into those wetlands and ponds. These are designed in a way to clean the water by mainly sedimentation and biodegradation [10]. The ponds are usually equipped with an emergency outlet to prevent overflow. By a short period of time usually close to 1 day, the runoff water is disposed through the soil near the pond [10]. Figure 2.5 illustrates how a wet pond works.

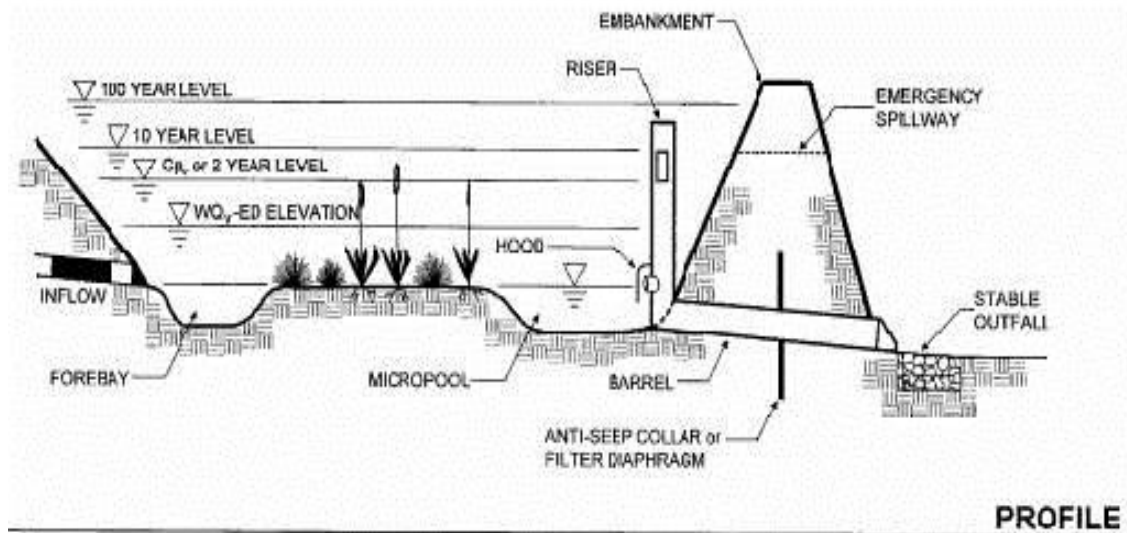

Figure 2.5: Wet Pond [11]

### 2.2.3 Sustainable Drainage in Urban Areas

In urban areas, wet ponds and wetland are not applicable due to the lack of space. The extended urbanization has caused the traditional draining system to fail in many cases. This problem has become critical with time causing a lot of damage and water pollution due to prolonged floods.

The introduction of concrete blocks permeable pavements (CBPP) has provided a great and sustainable solution for this problem [9]. The CBPP (Figure 2.6) allows the surface water runoff to go right through until it reaches the soil level where it dissipates underground. The CBPP are suitable for many applications including sidewalks, roads and parking spaces [9]. One of the major advantages of the CBPP is providing some sort of filtration for the water before it reaches the soil beneath.

CBPP can often be used without any drainage pipes underneath. Yet in some situations, it is mandatory to have a drainage pipes if saturated clay is underneath the pavement.



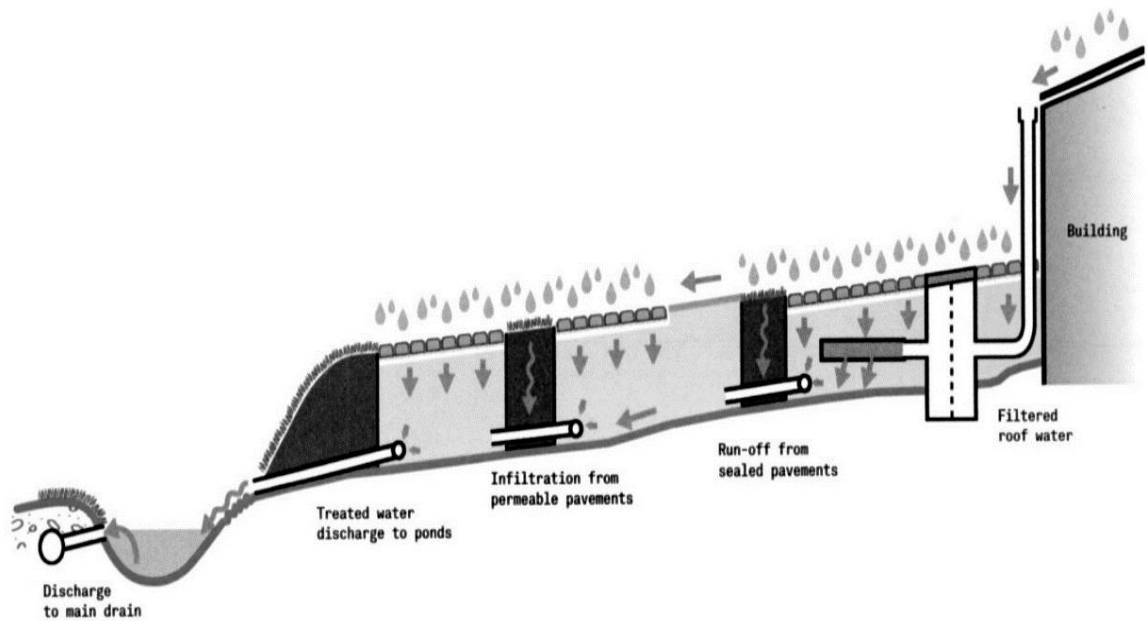

Figure 2.6: Concrete Blocks Permeable Pavement [9]

### 2.3 Rain and Grey Water

In a world of over 7 billion people, our natural resources are under a lot of pressure and are gradually depleted. The water demand problem has become a huge problem in many countries today and is only getting worse with time. Lakes and rivers have been gradually disappearing while underground water has been excessively used in some cases and polluted in other cases. The fresh water per capita may reach a point where our natural resources will not be able to cover the required demands. Not to mention that the depletion of fresh water sources is highly damaging the ecosystem.

Alternative green methods need to be adopted in order to find renewable sources of water. Two of the used concepts in green building are rainwater harvesting and grey water recycling which represent an efficient solution for providing new sources of non-potable water applications with minimum resources required to complete these two operations.

Rain and grey water can be used for the following:

- Toilet flushing which consumes a significant amount of water
- Irrigation which also need a lot of water
- Car wash
- Laundry
- Other applications

Rain and grey water recycling have many benefits:

- Reducing the fresh water bill consumption provided by municipalities.
- Reducing the pressure on the sewerage system [12].
- Reducing the water pollution and preserving natural resources.

### **2.3.1 Rain Water Harvesting**

Instead of putting extra pressure on our drainage structures and treating it like waste water, rain water should be harvested and reused in many applications.

The rain water harvesting is simple (Figure 2.7), rain water is usually collected from rooftops (green or normal roofs), then coarsely filtered before arriving to a storage tank (usually placed below ground) and finally pumped back to be reused in many applications mentioned earlier [12].

A feasibility study should be done to ensure the best efficiency of the installed system. Usually rain water harvesting systems face problems like unpredictability and dry periods throughout the year [12]. Yet the system is still considered to be very useful.

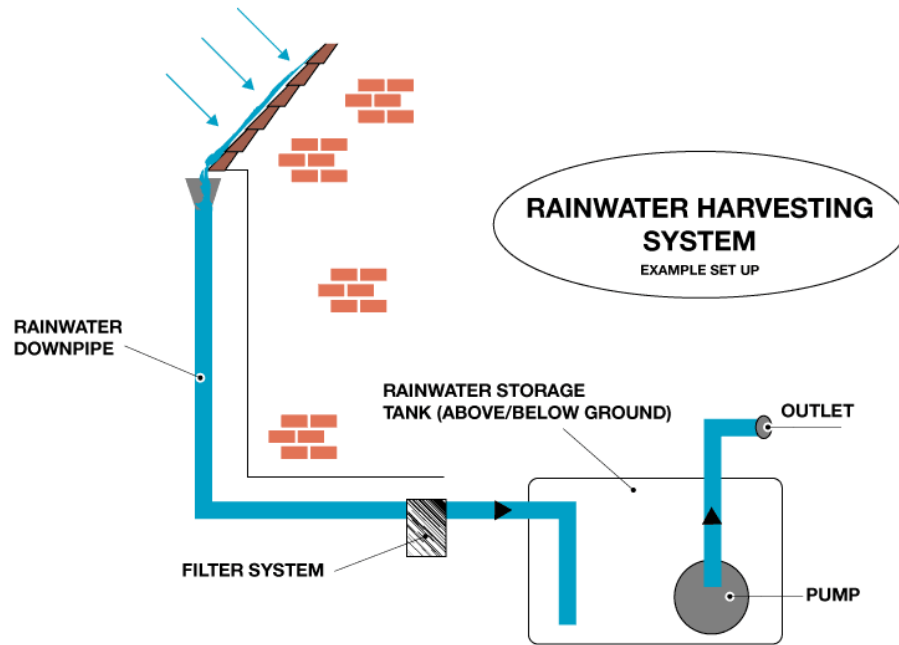

Figure 2.7: Rainwater Harvesting System [13]

Note that the system should take care of overflow by providing an emergency effluent pipe in case of overflow.

### 2.3.2 Grey Water Recycling

Grey water is the water we get after hand washing, dishwashing, laundry and bathing. Green water should be separated from black water which results from contact with human or animal waste [14].

Unlike rainwater which is considered to be fairly clean, grey water must be treated and purified before reusing it. There are many ways to treat grey water. It basically consists of filtering the water, then purifying it against biological or toxic components using agents like chlorine, bromine or UV light [14].

The purification or disinfection process shall be done preferably in a buffer storage tank which temporarily holds the water before it is piped into a main storage tank

which may or may not contain the harvested rain water. Finally, the water is pumped back to be reused.

The grey water system may cost a bit more than rain water harvesting and also requires maintenance, yet grey water quantities are usually continuous and can be predicted unlike rain water.

## **2.4 Sustainable Transportation**

### **2.4.1 Introduction**

The ever growing transportation sector has been increasingly responsible for a significant portion of air pollution, not to mention the indirect damages from the fuel and automobile industries. The transportation sector alone contributes in over 20% of the CO<sub>2</sub> and greenhouse gases emissions in the United States and Europe [15]. For that reason, the adoption of new sustainable transportation concepts is necessary (Figure 2.8).



Figure 2.8: Sustainable Transportation [16]

Sustainable transportation could be achieved by raising the public awareness for the importance of walking, cycling and using public transportation [17]. On the other

hand, infrastructures for sustainable transportation should be available inside and outside the cities.

Also new fuel and vehicle technologies are conducted to create small and fuel efficient vehicles for the private sector. Even though this sector is at no doubt promising, yet until today it is still considered not reliable due to the high cost of the vehicles being manufactured not to mention the availability of special fuel or electricity used to charge electrical and hybrid cars.

#### **2.4.2 Walking and Cycling**

Walking and cycling are very important features for sustainable transportation. They are very important not only to reduce the reliance on vehicles, yet they are also very important for our health and psyche [17]. This is why raising awareness through the media is very important to encourage these two types of transportation. On the other hand, infrastructure should be available in order to encourage these types of transportation. Livable streets are the best way to achieve that goal.



Figure 2.9: Livable Streets [18]

Livable streets [17] include the following features (Figure 2.9):

- Well-proportioned sidewalks and bicycle ways.
- Rich textures and decorations and transparency to increase curiosity.
- Planting trees and providing shading.
- Bicycle parking and benches.
- Diversity of shops and stores to provide all needs.

### **2.4.2 Public Transportation**

Public transportation should be affordable, comfortable, relatively fast and dignifying [17]. It also should include many options and be as frequent as possible [17]. Public transportation includes buses, tramways, subways and trains (Figure 2.10).



Figure 2.10: Tramway-Sustainable Transportation [19]

### **2.4.3 Cutting Distances**

Reducing travel distances is an excellent way to save time and cost and reduce pollution. Cutting distances through bridges is one of the oldest methods used in

efficient transportation. Some massive new bridges, like the Milau Bridge in France (Figure 2.11), are used to cut great distances.



Figure 2.11: Milau Bridge [20]

Another innovative method to reduce distances is conducting an overall analysis of the transportation daily streams in large cities between homes and location of jobs or public buildings (Figure 2.11) [15]. This study can help establish futuristic plans for designing the infrastructure in a way to reduce the required distances needed to reach certain destinations [15]. Such study has been done in Sydney.

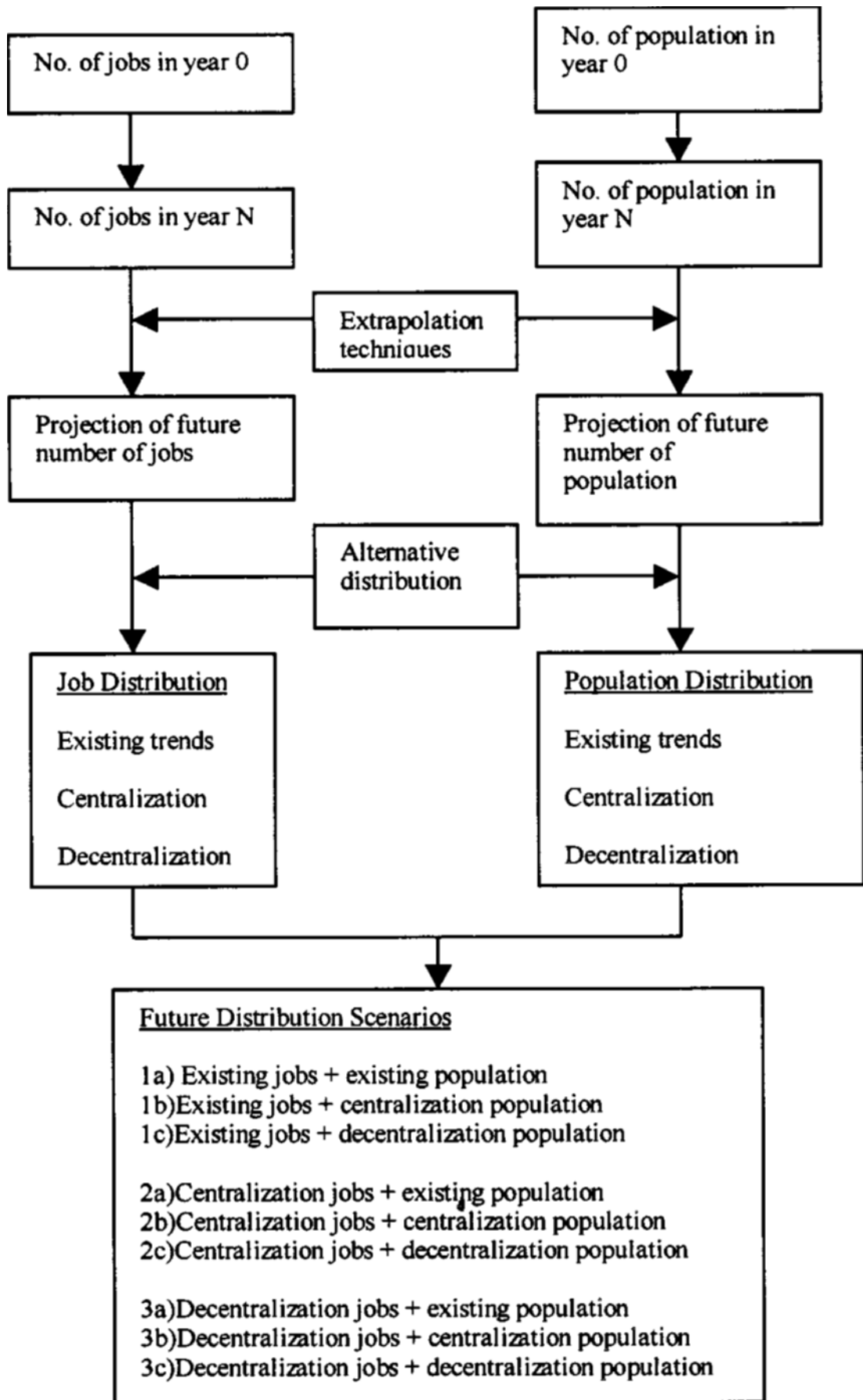

Figure 2.12: Sustainable urban transportation [15]



## **2.5 Cementitious Materials**

Cementitious materials are products which are meant to be added to and sometimes replace the traditional Portland cement. Cementitious materials are known to enhance many of the cements and concrete mix properties [21].

Most cementitious materials are by-products of other industrial processes [21]. Therefore, it is important to know that using these materials in the production of concrete is considered to be a recycling process.

The most commonly used cementitious materials are fly ash which is a bi-product of combustion of pulverized coal, ground granulated blast-furnace slag (GGBS) (Figure 2.14), silica fume and natural pozzolans.

### **2.5.1 Energy Saving and Reduced CO<sub>2</sub> Emissions**

The traditional Portland cement fabrication process (Figure 2.13) results in high CO<sub>2</sub> emissions where the cement industry has been estimated to produce about 5% of those emissions. The industry also consumes a lot of fuel and energy due to the requirement of high temperatures [22].

On the other hand, the use of other cementitious materials has been known to reduce the needed energy and temperatures in the fabrication and also it will significantly reduce the CO<sub>2</sub> emissions [22].

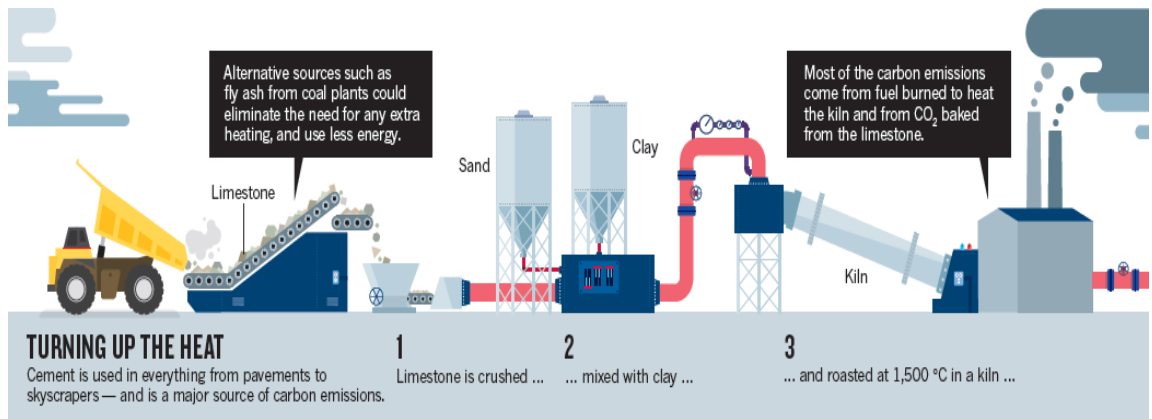

Figure 2.13: Cement Fabrication Process [22]

### 2.5.2 Technical Benefits



Figure 2.14: 50% GGBS used in the cement for the spinnaker tower [23]

Each cementitious material has its own effects on the final product of the cement or on the concrete mix in general. Yet, in general those materials enhance many properties of the concrete.

Fly ash for example has been known to increase the strength, chemical resistance, workability and pumpability of concrete [21]. In parallel, it reduces permeability and absorption of concrete. Also fly ash is used in the production of high strength concrete with compressive strengths reaching 100 MPa [21].

From the green point of view, these materials reduce the required amount of concrete and reinforcing steel needed for building design. Therefore, cementitious materials save more energy and natural resources needed for construction.

### **2.5.3 Modern Applications**

The modern applications of concrete are considered to be revolutionary in terms of green industry. The introduction of chemical admixtures and fibre reinforcement has resulted in the appearance of special types of durable and sustainable concrete products [21]. In some cases, these products may replace other expensive products.

For example, Polymer concrete (Figure 2.15) which is concrete containing polymers is used in the following applications:

- Structural and decorative construction panels.
- Sewer pipes and drainage channels.
- Swimming pools.



Figure 2.15: Application of Polymer Concrete [22]

## 2.6 Construction Waste



Figure 2.16: Construction Waste Disposal [23]

Construction sites produce a lot of construction waste during and after construction (Figure 2.16 and 2.17). During construction, the wasted material is made of wood, tiles, gypsum boards, concrete and other materials. The best way to deal with this

problem is to plan ahead in order to minimize the quantities of wasted construction materials [26].

The design should be optimized for a precise use of material quantities and sections. A continued monitoring through a construction waste plan and progress report should be conducted. Contacts with different specialized companies and organizations should be established to take advantage of any unused material [26].



Figure 2.17: Construction Waste [27]

Yet the main source of waste comes after the demolition of a building. It mainly consists of demolished reinforced concrete. More than 20 million cubic meters of concrete are used each year [26]. So, one can imagine the astonishing amount of waste which is very difficult to deal with. One of the solutions is to recycle the demolished concrete, more specifically, recycle the coarse aggregate which contributes in about 70% of the total concrete volume [26].



Figure 2.18: Recyclable Aggregates [28]

Recycled aggregates as in Figure 2.18 usually have less quality than new aggregates, yet concrete mixes that use these aggregates can still be efficient for many projects [26]. On the other hand, recycling the aggregates save money and material plus it get rids of a large portion of the construction waste. This may help reduce the environmental problems caused by the accumulation of these wastes.

## **2.7 Solar Energy**

### **2.7.1 Introduction**

Solar energy as Figure 2.19 is one of the most important renewable energies available today. This industry has witnessed many fluctuations throughout the history yet it remains a high developing industry overall and is gaining more interest especially since the year 2000 [29].



Figure 2.19: Solar Panels [30]

It represents a promising alternative for energy provided by fossil fuels like coal and oil. The fact that this industry relies on solar radiations to produce energy allows its spreading around the globe and gives it a high potential to become a principal source of energy in the future [29]. Figure 2.20 illustrates the high potential of solar energy production.

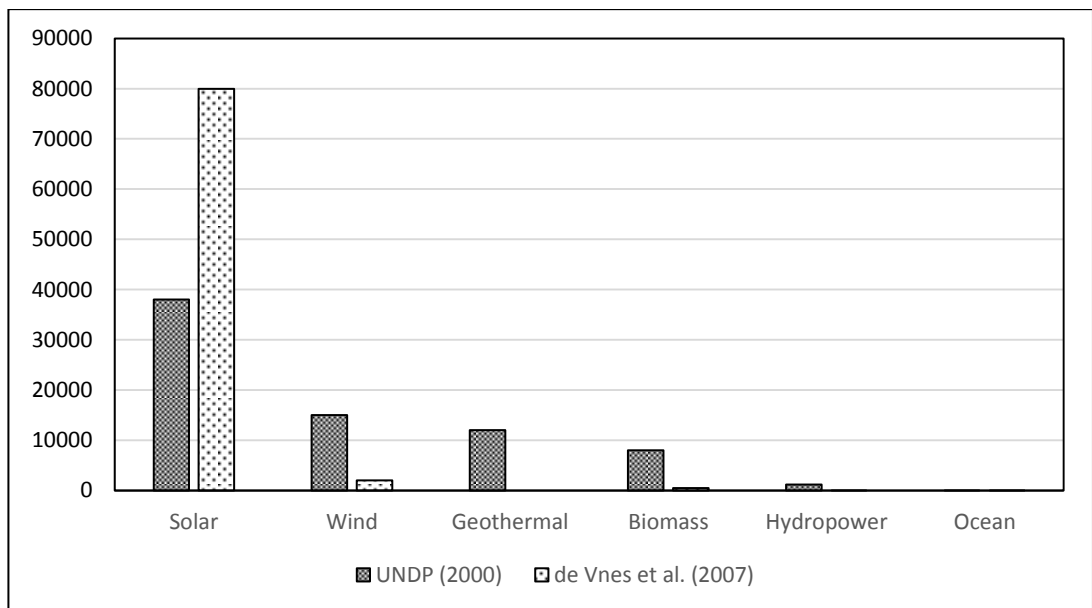

Figure 2.20: High Potential of Solar Energy [29]

### 2.7.2 Solar Energy Applications

Solar energy can be used in different manners. One can simply take advantage of natural lighting coming from the sun's radiations or can collect and convert these radiations into other forms of energy using solar panels [29].

There are two major types of solar panels which are available in the market and can produce electricity. The first one consists of photovoltaic cells which converts solar radiations into electricity (Figure 2.21). Crystalline-based PV cells are widely available in the market today. Thin film-technologies containing different types of semi-conductor materials are also used to fabricate PV cells and they are also currently available in the market [29].

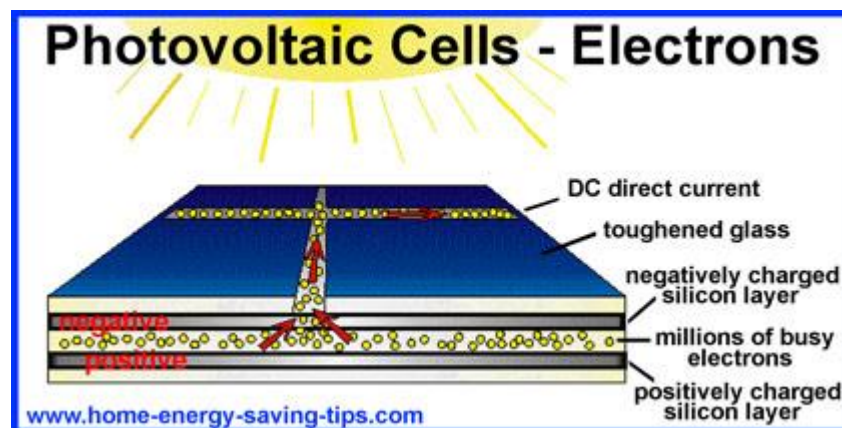

Figure 2.21: Photovoltaic Cells [31]

The second type is the solar thermal panel which harvest solar heat and use the captured heat in different applications. These panels are mostly used for water heating, whether for human consumption, heating systems (hot water in radiators or PVC piping in floors), or cooling systems (hot water driven chillers) [29]. They can also be used to produce electricity. Figure 2.22 illustrates how solar thermal panels can be used to produce electricity.



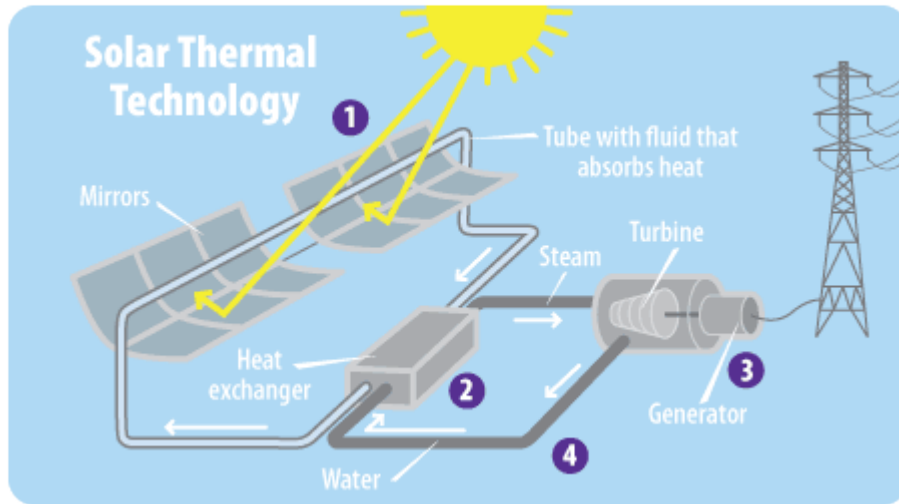

Figure 2.22: Solar Thermal Technology [32]

Thermal solar panels used for other purposes than the production of electricity are called solar collectors. There are many types of solar thermal panels like glazed, unglazed and evacuated tubes panels (Fig. 2.23). Yet the most used type is the evacuated tube panel for its high efficiency especially in hot weather [29].

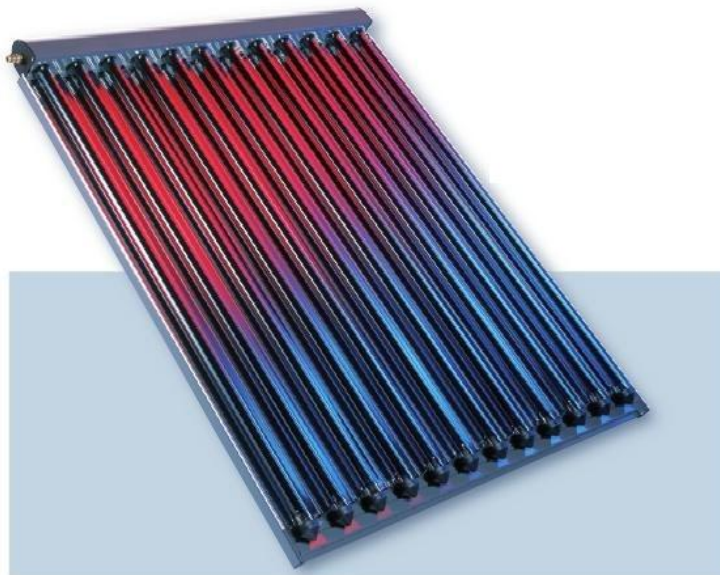

Figure 2.23: Evacuated Tube Solar Panel [30]

While PV solar panels spread widely in Germany (44% of the global PV installations), solar thermal panels are mostly spread in China (85% of the global installations) [29].

### **2.7.3 Solar Energy Economy**

With time, many innovations in the solar panel industry helped to reduce the high cost of energy production. For example, the installation cost of a PV system has decreased from \$16,000/kW in 1992 to about \$6,000/kW in 2008 [29]. Yet, this industry is still not competitive enough with the traditional energy production by fossil fuels such as oil and coal [29].

On the other hand, the main advantage of solar energy is the reduction of greenhouse emissions especially carbon dioxide. Also solar energy is a simple system and can be applied in any region including rural areas [29]. Therefore, this feature shall encourage governmental funding for this industry which can make it more feasible [29].

According to a research carried out by Saint Joseph University in Lebanon, water heating in 70% of the residential buildings depends mostly on the electricity source of power, 25% use diesel and the other sources of power (gas, wood, solar energy) only represents 5%. An identical research conducted at American University of Beirut showed that 60% of houses use electric heaters, 31% use diesel and 9% use the other sources of power [33].

## **Chapter 3**

### **GREEN BUILDINGS IN LEBANON**

#### **3.1 Introduction**

Lebanon is a small country located on the east cost of the Mediterranean Sea. It has witnessed a devastating 15 years of civil war which started in 1975 and ended up in 1990 by an agreement between the Lebanese parties held in Taiif, KSA. Lebanon lost about 144,000 people and suffered from heavy economic losses estimated between 80 and 160 billions of dollars during the civil war [34]. It has never been able to surpass the war's consequences. In fact, the country is currently going through a severe political crisis since the assassination of former PM Rafic Al-Hariri in 2005. This crisis has become far worse since the beginning of the Syrian civil war in 2011 as Lebanon shares more than 80% of his land borders with Syria. As a result, all the sectors in the Lebanese economy have been negatively affected. The infrastructure has also been severely damaged and some of its facilities are still malfunctioning and therefore, needs repair or replacement (Fig 3.1).



Figure 3.1: Abandoned Railways in Tripoli-Lebanon [35]

However, the construction sector remains very important in the Lebanese economy as investments in that sector contributes in about 21% of the national GDP. The construction industry in Lebanon mainly relies on reinforced concrete due to the availability and low cost of concrete in the Lebanese market compared to wood coming from ANKLISS Company located in Tripoli and structural steel distributed by YARED Company which imports steel from outside. The raw materials consisting of: gravel coming from local excavation company located in AMIOUN and DANNIEH, sand and cement from CHEKKA (AL SABAA and HOLCIM companies). The concrete industry in Lebanon is known to have huge success in the last decade, yet without proper planning, it remains a major threat to the environment in this small country (Figure 3.2).



Figure 3.2: Cement Process Plant in Chekka-Lebanon [36]

On the other hand, the bad political situation has affected many other industries in Lebanon. As a result, currently Lebanon imports about 80% of all the materials used inside buildings (excluding concrete).

### **3.2 Green Buildings in Lebanon**

The green industry in Lebanon is still in its early stages. The country's infrastructure needs maintenance and renovation especially when it comes to transportation and infrastructures for waste treatment. The public transportation sector in Lebanon is very weak. The only public transportation sector in existence today is the buses owned partially by private companies. There are no railways, metros or tramways in Lebanon.

In recent years, there are some governmental green projects in Lebanon, yet they only consist of relatively small projects. One of these projects is the Beirut river solar snake which uses solar panels to provide power for about 1000 homes(Figure 3.3).

Also, roads in Lebanon are gradually relying on solar lighting as an alternative to reduce the energy consumption.



Figure 3.3: Beirut River Solar Snake [37]

The government seeks the usage of green energy to cover the 12% of the country's needs for electricity. Also other projects like the rehabilitation of the abandoned national railways and the construction of waste treatment and recycling plants are still on paper.

Even though plans have been made by the government to support the green industry, so far, there are no serious governmental support for green industry in Lebanon, unlike the countries like the United States and countries in the European Union where significant plans and investments have been made to support this industry in its different forms. This may be due to the political and economic crisis in this small country.

On the other hand, many companies and non-governmental organisations in the private sector like the “Lebanon Green Building council” (LGBC) have stepped forward and took initiative to promote and use green products. As a result, green products, such as, solar panels, wind turbines and LED lights have widely spread and used in the Lebanese market.

In addition, many green buildings have been constructed in Lebanon such as the Beirut city centre (Fig. 3.4), Beirut terraces (Fig. 3.5) and many others. Compared to other countries in the region like the UAE, Lebanon is considered to be less involved in the green buildings industry.



Figure 3.4: Beirut City Centre [38]



Figure 3.5: Beirut Terraces [38]

## **3.4 BREEAM Certification**

### **3.4.1 Introduction**

There are many rating systems for green buildings such as LEED and BREEAM. The BREEAM first certification has still not been given to any building in Lebanon where all the certifications so far are based on the LEED rating system. Yet, the green building industry in Lebanon is still young, therefore there might be green buildings relying on BREEAM in the near future.



BREEAM was founded in 1990 by BRE in United Kingdom. It is the method used for rating and certifying sustainable buildings especially in UK.

According to Stuart Barlow in the Guide to BREEAM, the aim of this methodology is to grant:

- A credible, independently assessed sustainability label for buildings [40].
- Recognition of a building's sustainability credentials [40].
- A driver to stimulate demand for sustainable buildings [40].
- Assistance to clients and designers in mitigating life-cycle impacts of buildings [40].

### **3.4.2 Features of BREEAM**

The BREEAM provides the required standards for different schemes. They consist of 5 schemes as the following.

***BREEAM new construction:*** This standard is used in the design of new non-residential buildings in UK to measure the performance of the building [40].

***BREEAM international new construction:*** This standard is used outside the UK for the assessment of sustainability of new residential and non-residential buildings [40].

***BREEM in-use:*** The purpose is reduction of cost and enhancement of environmental performance of the existing buildings. It consists of three parts which are building asset, management and occupying management. The International Sustainability Alliance (ISA) uses widely BREEAM IN-USE [40].

**BREEAM refurbishment:** This standard is used for the design and the assessment of sustainable houses refurbishment projects [40].

**BREEM communities:** This one deals with the construction industry professionals to design successful environmental and economic places for people [40].

### **3.4.3 The Principles of BREEAM**

1. Make certain environmental quality through an available, holistic and fair measure of environmental impacts.
2. Assume a flexible approach, avoiding rigid specification and design solutions.
3. Use top available science as the basis for quantifying and calibrating a cost
4. Useful performance standard for defining environmental quality.
5. Replicate the social and economic benefits of meeting the environmental objectives covered.
6. Supply a common framework of assessment that is modified to meet the local context including regulation, climate and sector.
7. Add construction professionals in the development and operational processes to ensure wide understanding and convenience.
8. Approve third party certification to make certain independence, credibility and consistency of the label.

### **3.4.4 The BREEAM Assessment Process**

The following table shows the proposed schedule and process to be followed in a BREEAM assessment (figure 3.6).

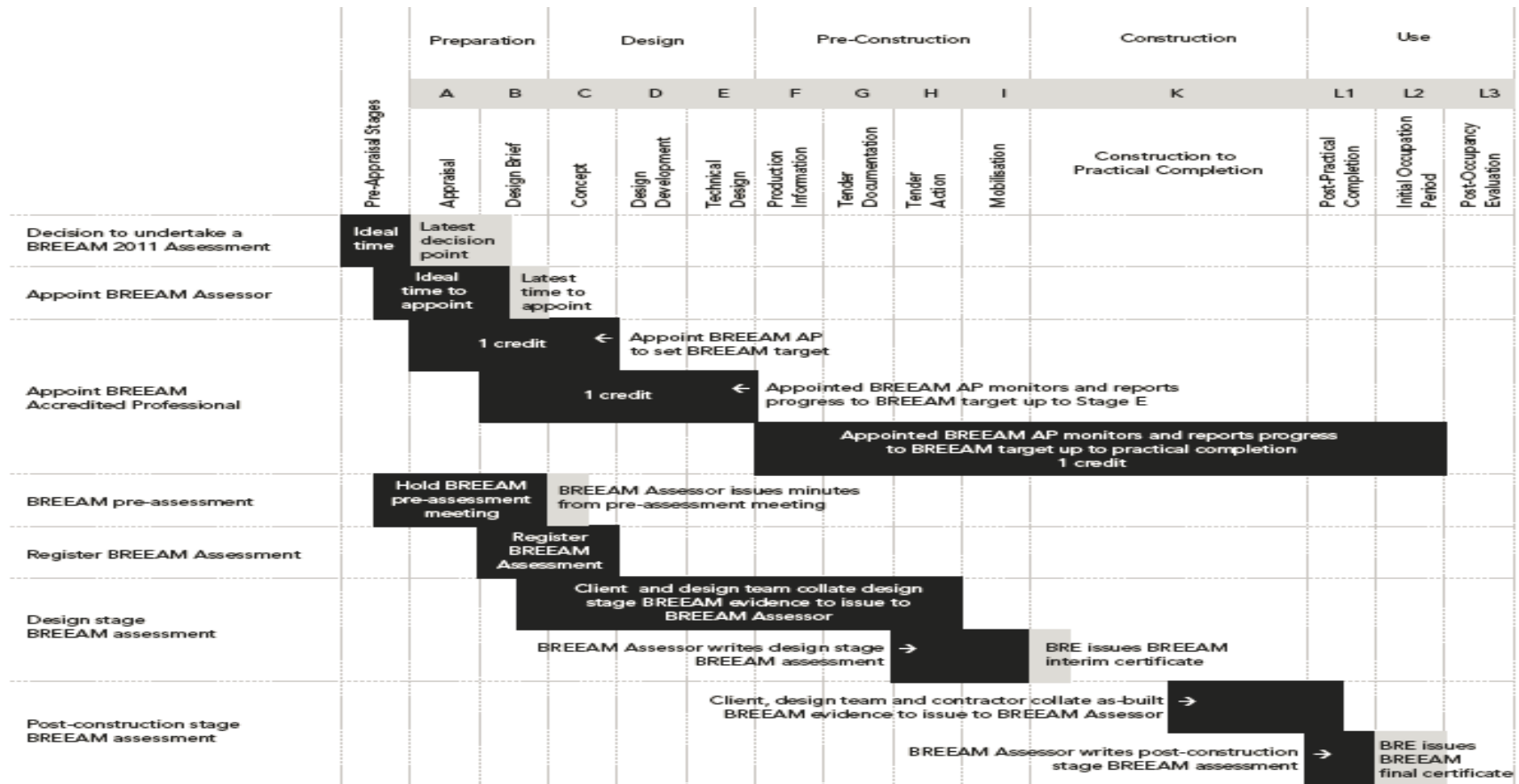

Figure 3.6: Assessment Process [41]

### **3.4.5 The Structure of a BREEAM Assessment**

The BREEAM consists of 9+1 categories:

- Management
- Health and well-being
- Energy
- Transport
- Water
- Materials
- Waste
- Land use and Ecology
- Pollution
- Innovation

### **3.4.6 Calculation of Building's BREEAM Rating**

1. The evaluator must verify the number of credits acquired in each environmental section in accordance with the criteria of each assessment subject.
2. Determine the percentage of credits achieved in each section.
3. Calculate the overall environmental section score in multiplying the percentage of credits achieved in each section by the corresponding section weighting (Table 3.1 and 3.2).

Table 3.1: Environmental Sections Weighting [41]

Environmental Section	Weighting
Management	12%
Health and wellbeing	15%
Energy	19%
Transport	8%
Water	6%
Materials	12.5%
Waste	7.5%
Land Use and Ecology	10%
Pollution	10%
Total	100%
Innovation	10%

Table 3.2: Rating of BREEAM [41]

Classification	Percentage
Unclassified	Less than 30%
Pass	Equal or more than 30% but less than 45%
Good	Equal or more than 45% but less than 55%
Very Good	Equal or more than 55% but less than 70%
Excellent	Equal or more than 70% but less than 85%
Outstanding	Equal or more than 85%

The overall score is calculated by adding section together then compared to the BREEAM rating benchmark levels in order to classify the final score of BREEAM.

In addition extra 1% can be added to the final BREEAM score for each innovation credit achieved.

### **3.5 Arz Certification**

In addition to the international rating systems, Lebanon has come up with its own local rating programme. The Lebanese green building council (LGBC) is a non-governmental organization that aims for the promotion of green buildings in Lebanon. The LGBC has launched a local Lebanese green building certification known as the “Arz certification”. It has its own rating which is designed to measure the sustainable behaviour of any building. The idea is similar to “LEED” and “BREEAM” yet the “Arz certification” is still in its early stages. A comparison between LEED and BREEAM, concerning history, strengths and weaknesses, is presented in chapter 4.

While LEED and BREEAM certifications offer many benefits like funding and special loans, the “Arz certification” is only symbolic so far. There are many trials to improve the programme yet this may take some time to get the necessary resources and funding.

## Chapter 4

### CASE STUDY: FACTORY 4376 RESIDENTIAL BUILDING

#### 4.1 Introduction

The Factory 4376 is a 10-storey luxurious residential building with 44 apartments including duplex apartments and 3 penthouses (Figure 4.1). The building has 3 basements used as parking and storage facilities. It is located on a land of 2200 m<sup>2</sup> and contains a large garden and playing ground in the original design. The project is still in the pre-construction stage.

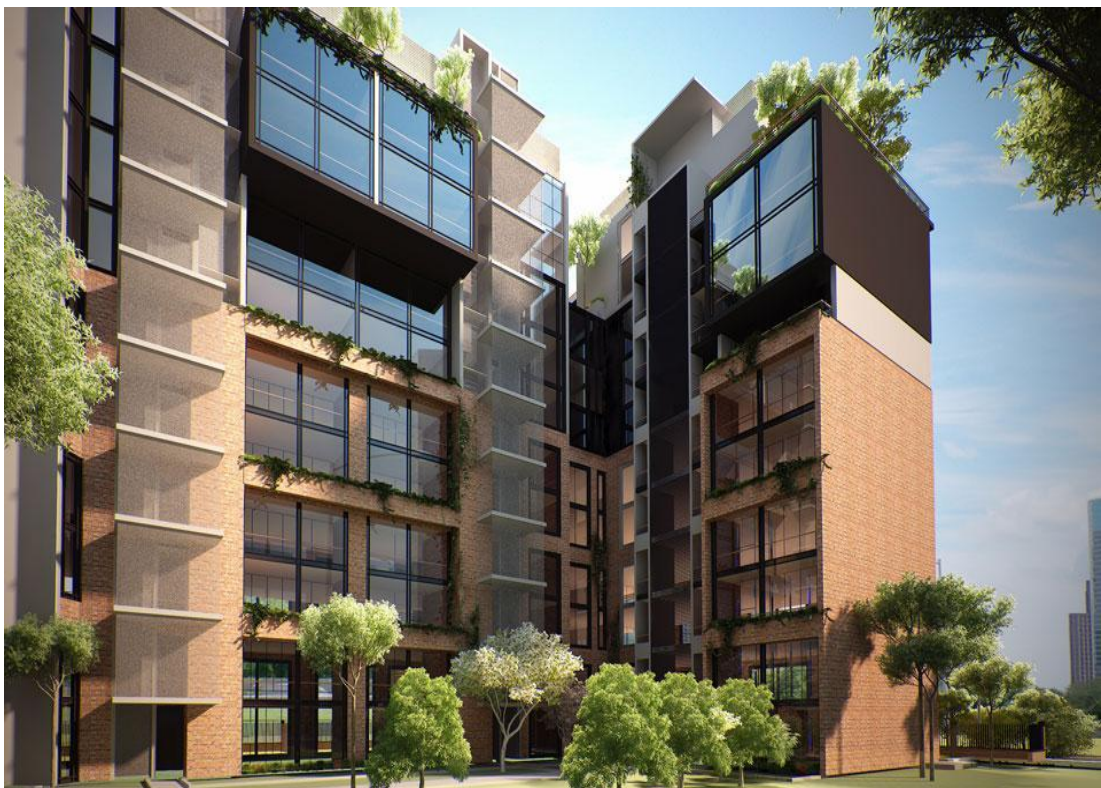

Figure 4.1: Factory 4376 Architectural 3-D view [42]

In this study, a preliminary design aiming for a BREEAM certification shall be conducted. The design shall take into consideration the condition of the Lebanese market and economy related to the green industry. It shall focus on feasible features that can be used in this project. The BREEAM international new construction technique manual shall be used as a reference for the design.

## **4.2 Design Overview**

The BREEAM international new construction manual focuses on every aspect in the building and gives credit in case of adequate and sustainable design. While some features can be fairly taken care of in this project, others are considered to be hard due to many factors including the location of the project, the market and the lack of governmental support for this type of projects.

In other words, this project can focus on BREEAM features like management, health and wellbeing, energy and water. While other features like transport, waste and ecology can be only considered in a basic manner. The reasons shall be discussed in the following sections.

Based on this concept, the project preliminary target is to get a “good” classification by getting 45 to 55 per cent of the total available credits (Table 3.2).



## 4.3 Management

### 4.3.1 Preliminary Design

Project management is one of the most important aspects in any project. Management constitutes 12% in weight of credits offered in a BREEAM certification. Therefore, it should be well taken care off in the FACTORY 4376 project.

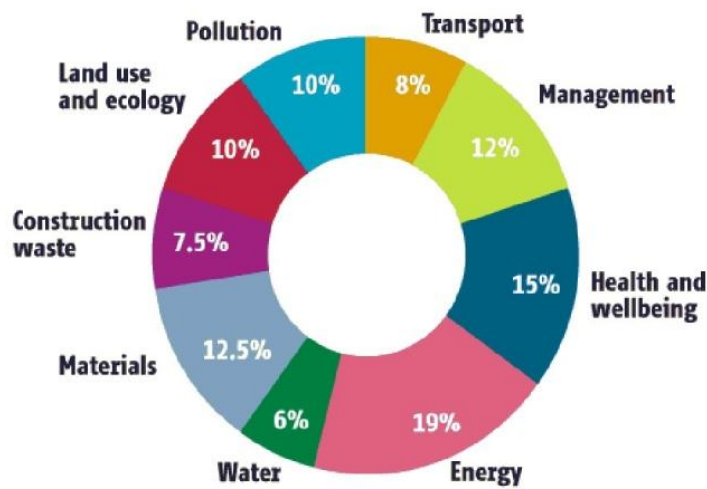

Figure 4.2: Sustainable Design [43]

According to BREEAM, the first step to take is to assign a BREEAM accredited professional who shall be present in the early stages of the project during the preliminary design. The AP (accredited professional) is responsible to demonstrate all the aspects of BREEAM that could be taken into consideration for the project. As mentioned before, this project shall focus on the energy, health and wellbeing and water features next to the management feature. On the other hand, due to the bad conditions of the transportation, waste treatment and recycling infrastructure in Lebanon, the design shall not focus on features like waste and transportation.

This shall provide a good start for the project that can simplify the design and construction phases later on. The AP shall provide reports and evidence that summarize the results. These criteria can be found under Man 01 in BREEAM.

#### **4.3.2 Construction Phase**

The AP has an important role to play during the construction phase of the Factory 3476. He should take care of constant monitoring and organization of the construction site. Responsible construction practices mentioned in Man 02 in BREEAM are required and listed in BREEAM [41]. These practices include safety measurements, clear and safe entrances and exits, appropriate reception areas, announcements of noisy working hours for the neighbors and others.

In addition, monitoring the site's energy and water consumption is mandatory. The electricity consumption shall be measured in "kW.hr" and water consumption in liters or equivalent units [41]. Also all materials coming inside and getting outside the site shall be monitored by providing destinations and distances covered from the main factory to the site or from the site to their final destination [41].

Another aspect of management is the materials life cycle cost monitoring. A full study shall be provided for the life cycle and cost of main materials used on the site. An advanced analysis can be conducted for extra credits [41]. It shall consist of a comparison between different types of materials. For example, cladding can be done using stone cladding or concrete panels. Concrete panels are more feasible than stone cladding due to its lower cost, lighter weight and easy installation with good aesthetic results. For this reason, Factory 3476 shall use concrete cladding rather than stone cladding (Figure 4.3).



Figure 4.3: Concrete Cladding [44]

One last step is to provide the stakeholders or residents with full information about the building and rising awareness about certain environmental practices in order to enhance the general performance of the building[41]. This is mentioned in Man 04b in BREEAM.

#### **4.4 Health and Wellbeing**

In this feature, the BREEAM focuses on aspects like visual, thermal and acoustic comfort for the residents. It also focuses on the inside air and water quality [41]. In addition, BREEAM suggest providing some private spaces and safety measures for the residents [41].

One should know that the BREEAM certification provides computer software for its accredited professionals in order to evaluate any aspect in the building [41]. In this case, only a preliminary design shall be provided excluding any detailed calculations conducted by the software.

The factory 4376 project holds a lot of potential for providing an excellent health and wellbeing (Figure 4.4). Its unique design allows daylight to reach almost all areas inside the dwellings. Also the vegetation inside the building, the large garden in its property and the fair vegetation around it provide an excellent view from most of its sides. In addition, the vegetation shall help purify the air and improve its air quality.



Figure 4.4: Pool Area in Factory 4376 [45]

On the other hand, Factory 4376 is located at the edge of Beirut, which has a nice moderate weather consisting of 4 seasons throughout the year. Well-designed heating and cooling systems along with good insulation shall be provided for maximum thermal comfort. Municipal potable water, grey water and rainwater harvesting and treatment systems shall be used in this project. Therefore, the key for a good water

quality consists of a constant monitoring to the water along with necessary treatment measures if needed (Figure 4.5).



Figure 4.5: Apartment in Factory 4376 [45]

A guard, security cameras and car entrances with an automated system shall be provided to ensure safety for the residents.

Other features concerning health like the low VOC (Volatile Organic Compounds) materials shall be discussed later on.

## 4.5 Energy and Water Efficiency

This topic is also of great importance in this project. Energy and water efficiency shall be achieved using the proper efficient equipment and complete systems that shall reduce the energy consumption in the building.

### 4.5.1 Efficient Equipment

The use of good products in the project can lead to a great reduction in the energy and water consumption. For the lighting, LED lights shall be used instead of ordinary lights (Figure 4.6). These products can be easily found in the Lebanese market with many applications for indoor and outdoor lighting. Although they cost more than ordinary lights, LED lights are more durable and more efficient. Therefore they can reduce the total energy cost of the building. The problem with such products is the direct cost which is usually spent by the contractor rather than the stakeholder, yet they are considered to be very important for energy reduction.



Figure 4.6: LED Lights [46]

In addition, heating solar panels which are widely spread in the Lebanese market shall be used for water heating whether used for heating floors and radiators or for

sanitary use. Factory has a wide roof space that can be used for the installation of these panels. These products are much more appealing for residents in the Lebanese market and are used very often. Therefore, residents may be willing to pay extra money for these products.

Central air conditioning shall be provided for the building. This system shall be a VRF (Variable Refrigerant Flow) system. It is a system known to reduce the energy consumption by regulating the cooling or heating system whether by manual control by the residents or by automatic control based on the indoor temperatures (Figure 4.7).

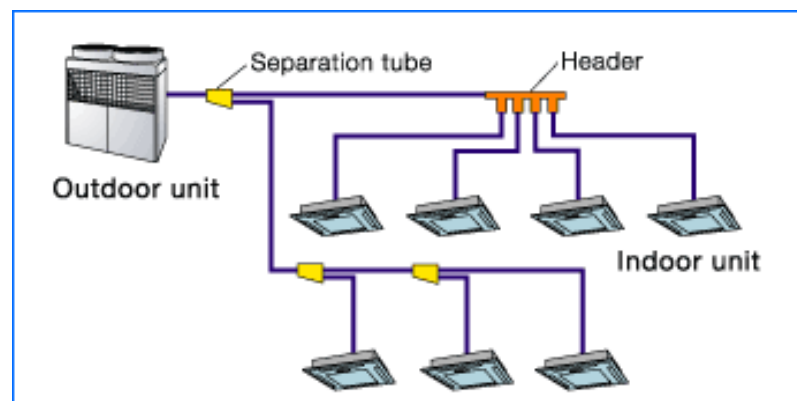

Figure 4.7: VRF System [47]

On the other hand, water efficient products such as advanced double flushing toilets and efficient water faucets are available in the market and shall be used in this building (Figure 4.8).



Figure 4.8: Double Flush Toilets [48]

#### 4.5.2 LED vs. Fluorescent Lighting

In this paragraph a small comparison is done between LED and fluorescent lighting.

Fig 4.9 illustrates the efficiency of different types of light systems.

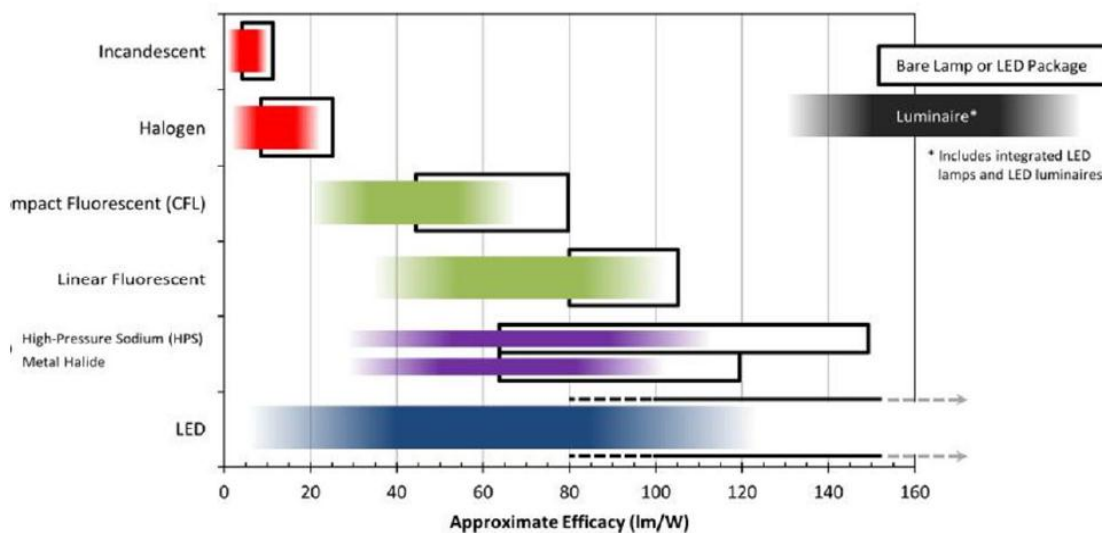

Figure 4.9: Lighting Efficiency [49]

As one can notice, LED lighting is almost twice as efficient as fluorescent lighting.

In other words a 15 W LED bulb can produce the same amount of light compared to a fluorescent light bulb. On the other hand, A LED bulb has a lifetime of almost 20 years while a fluorescent light has a lifetime of about 3 years.



Tables 4.1 and 4.2 compares between the 2 types of lighting based on a cost of 0.133USD/kW.hr charged by the Lebanese government.

Table 4.1: LED vs. Fluorescent - Material Cost

	Life Span (years)	Replacements in 20 years	Cost/Unit (USD)	Total Cost (USD)
Fluorescent	3	7	2.25	15.75
LED	20	1	22	22

Table 4.2: LED vs. Fluorescent - Energy Cost

	Watts	Usage in 20 years (hours)	kW.hours in 20 years (kW.hr)	Cost (USD)
Fluorescent	36	58400	2102	280.25
LED	20	58400	1168	155.7

The total cost in 20 years is 296 USD for fluorescent lighting and 177.7 USD for LED lighting. Therefore, LED lighting is much more feasible on the long term and it consumes less energy.

### 4.5.3 Efficient Systems

As mentioned earlier, solar panels shall be used in order to install a solar water-heating system on the roof. In addition, the roof shall be designed as an extensive green roof (Figure 4.10). Green roofs, as discussed in chapter 2, have many advantages including a good insulation, and rainwater harvesting. These two features in a green roof shall reduce the load for cooling and heating and collect rainwater in order to be used for different application like irrigation. Therefore the roof shall be a combination of a green extensive roof with installed solar panels and an integrated rainwater harvesting system discussed in Chapter 2.



Figure 4.10: Green Roof with solar panels [50]

Along with the rainwater harvesting system, rainwater can be directly collected in the outside garden of the building using barrels (Figure 4.11). Also a grey water

collection and treatment system discussed in Chapter 2 shall be incorporated in the project where the storage tanks can be buried in the garden.



Figure 4.11: Rain Barrels [51]

On the other hand, an insulation system relying on the green roof, double glazed doors and windows with proper shading in the summer in addition to double masonry walls with a Styrofoam medium shall reduce both thermal and acoustic infiltration. This shall reduce the heating and cooling load and provide acoustic and thermal comfort for the residents.

BREEAM also recommends a constant monitoring of the water and electricity consumption of the building. The calculations are made using software provided by BREEAM to their accredited professionals [41].

#### 4.5.4 Water Heating Solar Panels

Studies have shown that in a country like Lebanon where the solar energy is available at most times of the year, using solar panels can reduce the water heating bill by up to 70% [42].

The following is a study showing the efficiency of water heating solar panels in Lebanon. Each apartment uses about 240 Liters of hot water per day. Water heating solar panels with a capacity of 250 Liters are available for a price of 1500USD/panel. This panel is available in the Lebanese market and has a life span of about 20 years.

Software supplied by the U.S. government is used to calculate the water heating bill for the usage of conventional water heaters in (Figure 4.12).

INPUT SECTION	
Input the following data (if any parameter is missing, calculator will set to default value).	
Type of Water Heater	Gas
Average Daily Usage (gallons per day)*	64 gallons
Energy Factor†	0.53
Energy Cost	\$1.1 / therm
Quantity of Water Heaters to be Purchased	1 unit(s)

Figure 4.12: Water Heating Calculator [52]

For each apartment in Factory “4376”, the annual cost per year for water heating using conventional methods is 309 USD. Therefore for 20 years, the cost would be 6,180 USD.

On the other hand, in case of using the water heating solar panel as an additional system for water heating the cost would be reduced by about 70%. Therefore, the total cost for using a double system of conventional and solar heating would be as follows:

$$\text{Total Cost} = 1500\text{USD} + 30\% \times 6,180\text{USD} = 3354\text{USD}$$

Therefore, solar water heating panels are feasible and advisable to use.

#### **4.5.5 Thermal Insulation**

Double masonry walls and double glazed doors and windows are used in this project for a better thermal insulation, and thus it leads to less energy consumption. According to LGBC (Lebanese green building council), glazing alone helps reduce of the total electricity bill for the entire building by around 25% [53]. Yet is it cost-efficient? In Lebanon, the cost of double glazed doors and windows is approximately 200USD/m<sup>2</sup> and 150USD/m<sup>2</sup> for single one. On the other hand, the average electricity bill for an apartment is about 1000USD/year.

In “Factory 4376” each apartment contains approximately 30 m<sup>2</sup> of doors and windows. Thus, the additional cost for the use of double glazed systems is as follows:

$$\text{Double Glazing Cost per apartment} = 200 \times 30 = 6000\text{USD}$$

$$\text{Single Glazing Cost per apartment} = 150 \times 30 = 4500\text{USD}$$

$$\text{Difference in cost} = 6000 - 4,500 = 1,500\text{USD}$$

The total period needed to break even is as follows.

$$\text{Break even period} = \frac{1,500\text{USD}}{25\% \times 1000 \text{ USD}} = 6 \text{ years}$$

Therefore, the double glazing system is efficient. Yet it does reduce the consumption of energy which is beneficial for the environment.

#### **4.6 Transportation**

Transportation in Beirut and its suburbs has a moderate infrastructure and a poor public transportation system. The only public transportation option is the use of buses. Figure 4.13 shows that the “Factory 4376” project is located near two bus stations.

This is considered to be important for the BREEAM assessment as the transportation section takes into account this criterion. According to BREEAM, the building under consideration is required to be close to a public transportation. This can be a bus stop within 650 meters of the building, a railway station, a tram stop or a ferry terminal within 1000 meters of the building[41]. An accessibility index is measured by taking into account the distance from the building to the nearest station and the rate of trips per hour available in that station. For example, a bus station with one service every 15 minutes and 300m from the building entrance will achieve an AI (accessibility index) of 2.26.

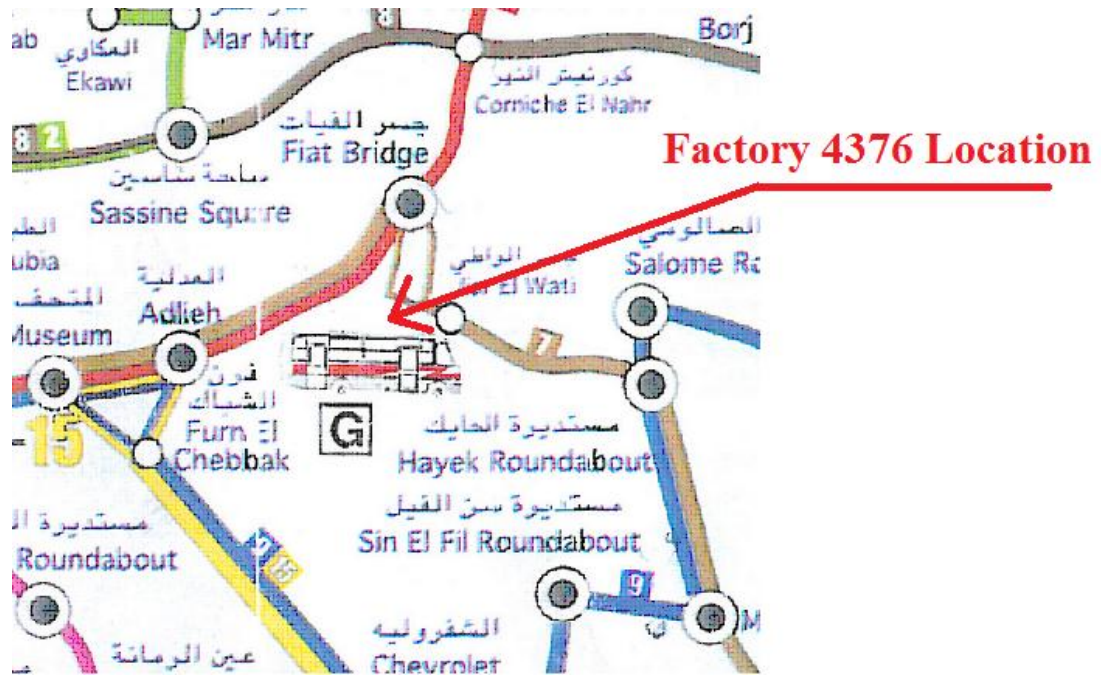

Figure 4.13: Beirut Bus Transportation System [54]

Other criterion that should be taken into consideration in this section includes the encouragement of using an alternative transportation. For example, the manager can launch negotiations with the local authorities in order to improve the cycling network in the designated areas by taking the necessary measures. It is important to have special sidewalks for bicycles including bicycle parking. Also, the availability of different amenities including different shops near the building can be a great replacement for distant malls where residents need to cover a lot of distances to get there. The Factory 4376 is located near a popular market called “Souq al ahad”. Residents can use sustainable transportation options like cycling or even walking to get to this market and buy their necessities.

#### 4.7 Materials

A life cycle impact of a building represents the whole environmental effects in the construction, occupancy and demolition phase of the building [55]. BREEAM focuses on the life cycle impact of products used in the construction. A study on the

materials used during the construction and occupancy phase should be conducted. This study should include all the input available from the product's construction phase at the factory until its disposal or recycling.

Studies have shown that the 80% to 90% of the total residential buildings life cycle impact is at the occupancy phase [55]. Therefore the designer should take into consideration the materials used at this phase. One of the most important materials with the highest impact is paints and coatings.

Thus, there are recommendations for the usage of low-to-zero-VOC latex paint in (Figure 4.14) [56]. These paints can significantly reduce the VOC index of the whole building and should be used in the “Factory 4376” project. They are available in the Lebanese market and are recommended by LGBC (Lebanese Green Buildings Council).



Figure 4.14: Zero VOC latex paint [57]

In addition, all the energy and water efficient materials and systems used in this project shall lower the LCI index of the building.



On the other hand, BREEAM recommends the use of recycled materials in the construction process, specifically the use of recycled aggregates in concrete. Unfortunately, this feature is not available in Lebanon and cannot be applied in this project.

#### **4.8 BREEAM vs. LEED**

LEED which stands to Leadership in Energy and Environmental Design was founded in 1998 by the US Green Building Council (USGBC). This rating system is becoming more known and used worldwide because several countries are following it in order to certify their buildings. Yet, USGBC has declared that 51,700 projects were evaluated worldwide using LEED.

On the other hand, BREEAM which stands for Building Research Establishment Environmental Assessment Method was founded in 1990 by the Building Research Establishment (BRE) in United Kingdom. This rating system is being applicable mostly in UK.

Table 4.3 shows the point of weaknesses and strengths between LEED and BREEAM.

Table 4.3: Comparison of the weakness and strength of LEED and BREEAM

Scheme	Weaknesses	Strengths
BREEAM	<ul style="list-style-type: none"> <li>• Requirements are very exact</li> <li>• Market profile</li> <li>• Weighting system is complex</li> <li>• Cost of compliance</li> </ul>	<ul style="list-style-type: none"> <li>• Independently audited</li> <li>• Assess any building with the bespoke version</li> <li>• Allows comparison and benchmarking of different building</li> </ul>

LEED	<ul style="list-style-type: none"> <li>• Based on US system</li> <li>• No independent audit of the assessment</li> <li>• Intense documentation required</li> <li>• Difficult to assess mixing building function and form</li> </ul>	<ul style="list-style-type: none"> <li>• Availability of various information</li> <li>• No demand for training and assessor</li> <li>• Strong marketing get message through</li> </ul>
------	---	--

Normally it is not correct to compare BREEAM and LEED. Both are used for certifying buildings in the world. Thus, the table 4.4 shows the percentage of focus of LEED and BREEAM in various topics.

Table 4.4: Percentage for each topic by LEED and BREEAM

BREEAM	Percentage	LEED	Percentage
Site selection and ecology	20.5%	Site selection	24.5%
Water	2.5%	Water	5.5%
Energy	33%	Energy	33%
Materials	13.5%	Materials	13.5%
Indoor environmental quality	13%	Indoor environmental quality	14%
Innovation	6.5%	Innovation	6.5%
Facility management	12%	Regional priority	4%

## 4.9 Analysis and Discussions

This case study shows many sustainable options that can be used particularly in this project. One should notice that the “Factory 4376” consists of luxurious apartments which will be sold to a specific type of customers that are willing to pay for a high quality construction. This may cover the additional expenses for all the sustainable features that will be available in the building.

In order to achieve "Good" classification according to BREEAM, the features that should be applied in the preliminary design are summarized in tables 4.5 to 4.8:

Table 4.5: Management Category

<b>Management</b>	<b>Results</b>
Monitoring and organization of the construction site	✓
Safety measurements	✓
Clear and safe entrances and exits	✓
Appropriate reception areas	✓
Announcements of noisy working hours for the neighbors	✓
Materials life cycle cost monitoring	✓

Table 4.6: Transportation Category

<b>Transportation</b>	<b>Results</b>
Bus station	✓
Side walks for bicycles	X
Located near to popular Market	✓
Metro, tramway	X

Table 4.7: Health Category

Health	Results
Vegetation inside and around building	✓
Large garden around the building	✓
Zero VOC latex paint	✓

Table 4.8: Energy and Water Categories

Extensive Green roof	✓
Double Flush Toilets	✓
Rainwater harvesting system	✓
Double masonry walls	✓
Central air conditioning system	✓
Windows with proper shading	✓

On the other hand, these features may be difficult to achieve in most of the buildings in Beirut. Even though many of them are feasible, yet the direct cost is only carried by the contractor while most customers in Lebanon are seeking low prices rather than sustainability. This is due to the lack of awareness for the advantages of green buildings among the Lebanese people and is illustrated in Chapter 5.

## Chapter 5

### SURVEY ANALYSIS, RESULTS AND DISCUSSIONS

#### 5.1 Introduction

In this chapter, the results of the survey shall be analysed and discussed. The aim of this survey is to capture the Lebanese public opinion regarding the concept of green buildings. It will reflect the degree of awareness towards the advantages of sustainable buildings. It will also test the knowledge of the Lebanese people about green buildings and their features in Lebanon. The survey is given in appendix A.

A total of 99 people participated in this survey. The following table shows the distribution of the specimen selected according to age, gender, education including civil and mechanical engineer and architecture and status.

Table 5.1: Specimen Distribution

Age:	22-32 47	33-43 32	44-55 20
Gender:	Male 64	Female 35	
Status:	Single 69	Married 30	
Education:	Educated 83	Non-Educated 16	
Civil engineer	37		
Mechanical engineer	15		
Architect	31		
Nationality:	Lebanese 87	Others 12	

## 5.2 Results and Analysis

### 5.2.1 Question 1

This question tends to recognize which categories of people have heard about Green Buildings. The results in Figures 5.1 and 5.2 show that the majority (81%) know what “Green Building” is and most of them are Males (56%) and especially between the ages of 22-32 (39%). In addition, it is obviously seen that the majority are educated (69%) and single (54%). These results are obtained because the single ones are more interested in searching for new building, and because of their education and age, they are more conscious of it; thus, they are more open to try what is new on offer.

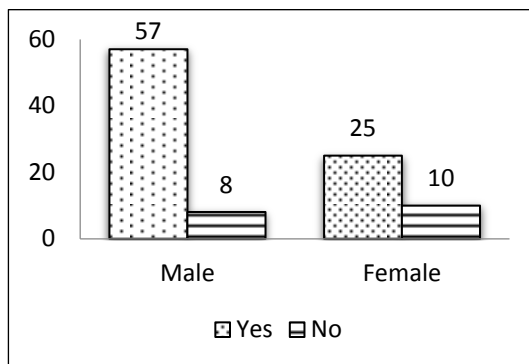

Figure 5.1: Question 1-Gender Bar Chart

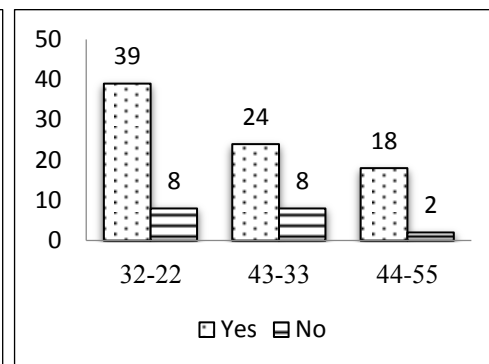

Figure 5.2: Question 1-Age Group

### 5.2.2 Question 2

Question 2 shows that 82% do not heard about ARZ certification in Lebanon. This question proves that ARZ certification is not known well or spread enough among Lebanese people.

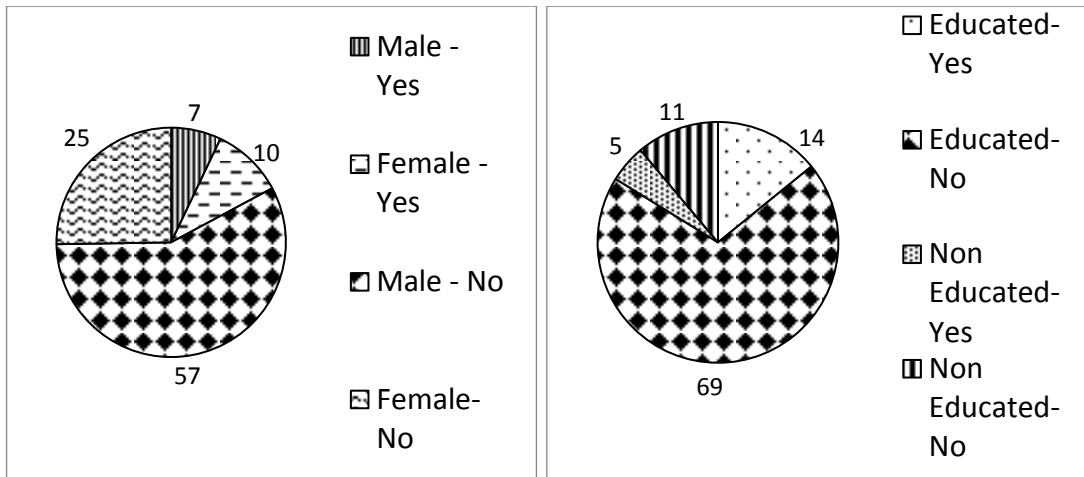

Figure 5.3: Question 2-Gender Pie Chart Figure 5.4: Question 2-Education Pie Chart

### 5.2.3 Question 3

The question indicates that 80% know the difference between traditional and sustainable house. As can be seen, most of them are educated and between the ages of: 22-32 as shown in Figure 5.6. It can be highlighted that most people have an idea about sustainable building from different perspectives. And for the others have a superficial idea.

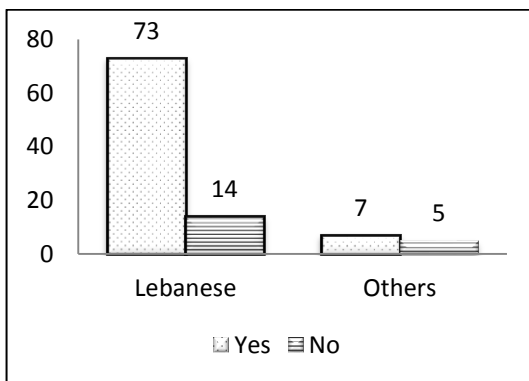

Figure 5.5: Question 3-Nationality Bar Chart

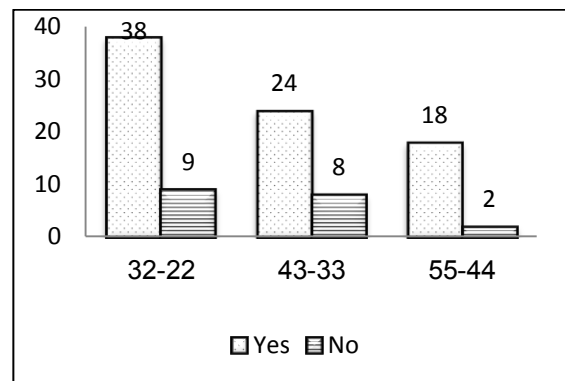

Figure 5.6: Question 3-Age Group Bar Chart

### 5.2.4 Question 4

The results of this question inform that some people (41%) prefer their traditional houses and others (58%) prefer the sustainable ones (Figures 5.7 and 5.8). The

survey shows that younger people have more potential for selecting sustainable houses; however people above the age of 44 are more attached to traditional houses. Similar educated people are more aware of current issues and therefore they also prefer sustainable houses.

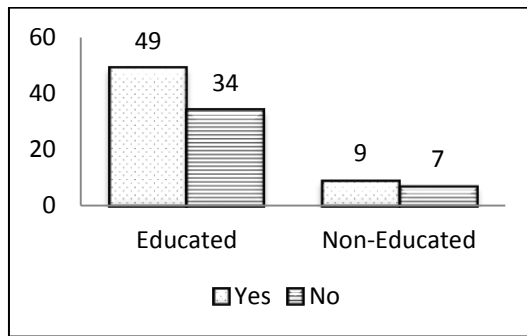

Figure 5.7: Question 4-Nationality Bar Chart

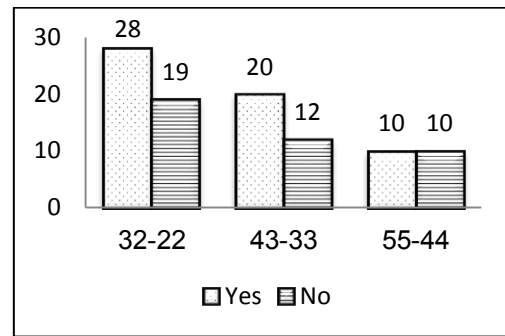

Figure 5.8: Question 4-Age Group Bar Chart

### 5.2.5 Question 5

It is clear that people have economic concerns and that is why they prefer to have greenhouse but do not accept to buy a greenhouse that would cost more than a traditional one.

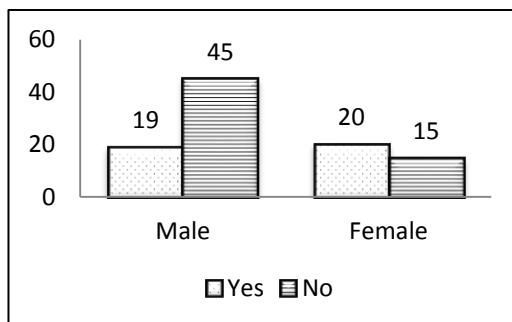

Figure 5.9: Question 5-Gender Bar Chart

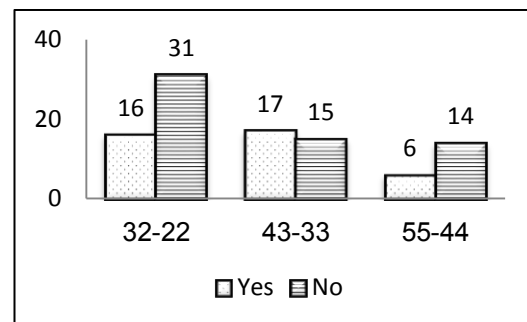

Figure 5.10: Question 5-Age Group Bar Chart

### 5.2.6 Question 6

According to the answers of this question 66% of the people are inclined to build a traditional residential house on their land. Despite of the 33% preference of people



towards sustainable building, majority of the people would like to live in a traditional building. However, it is worth noting that even the educated ones prefer traditional residential houses that assure for a good future for our generation (Figure 5.11).

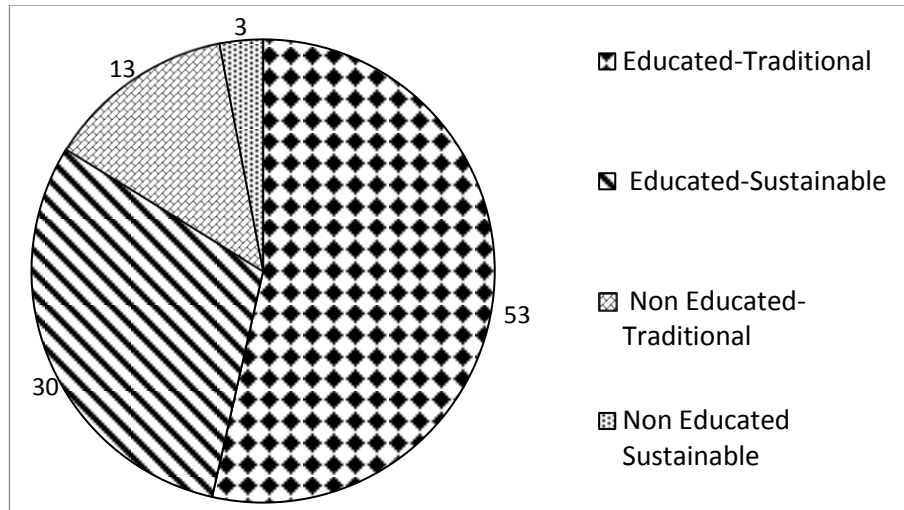

Figure 5.11: Question 6-Education Pie Chart

### 5.2.7 Question 7

This question highlights that 49% of the people that took part in this survey have poor knowledge about sustainable building. Moreover, it also confirms that there is not enough sustainable building in Lebanon.

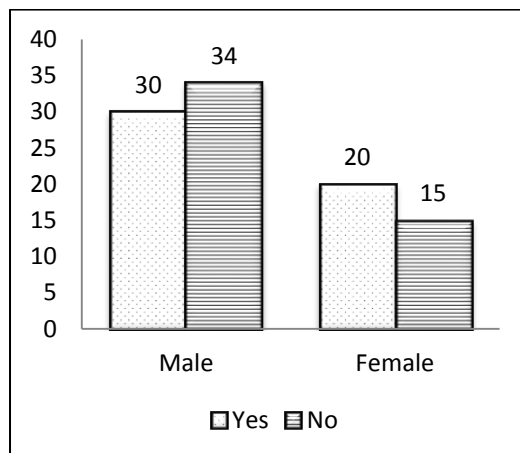

Figure 5.12: Question 7-Gender Bar Chart

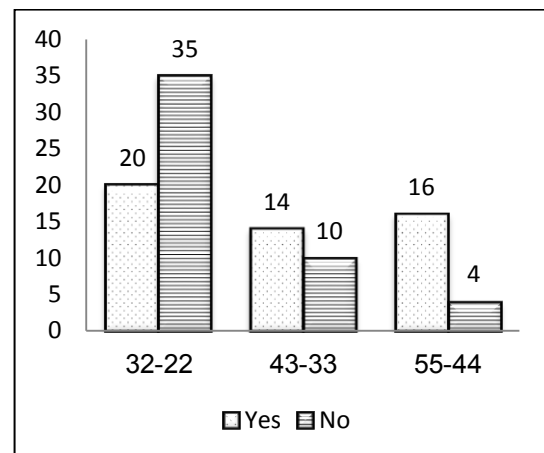

Figure 5.13: Question 7-Age Group Bar Chart

### 5.2.8 Question 8-9

38% consider stone as the construction materials used in Green Buildings and another 38% consider steel as a useful material for green buildings. Nevertheless 23% believes that reinforced concrete is a green building material. This comparison between the three materials made it difficult and confusing for people to choose among them as shown in figures 5.14 and 5.15. That why the results in question 9 nominate Melenio Centre as Green building. In addition people also consider Beirut centre and Marina centre as a Green Building because the results are so close to each other.

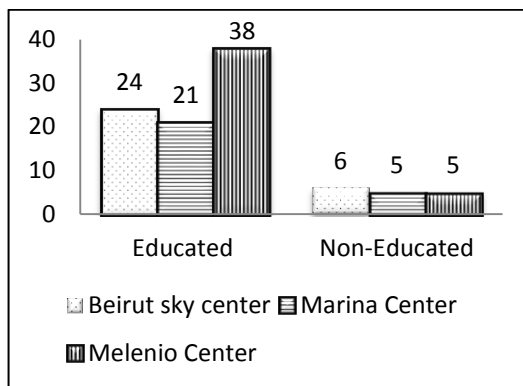

Figure 5.14: Question 9-Education Bar Chart

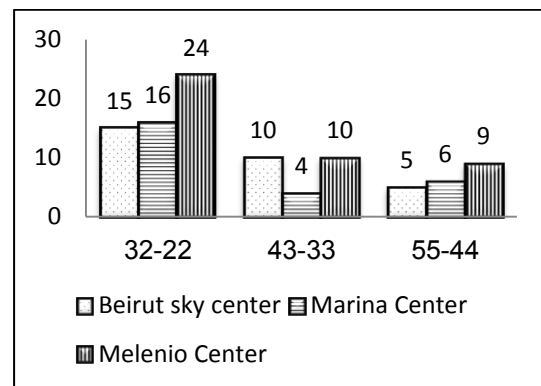

Figure 5.15: Question 9-Age Group Bar Chart

### 5.2.9 Question 10

This question clarifies the cognition of people about the specialty of sustainable house. Most people relate sustainability to the quality of the materials used. Others think that it is related to the environment. However, a small percentage of respondents consider cost is the differentiating factor. It is important to highlight that majority of the people who are educated especially Engineer relate sustainability to materials rather than cost (Figure 5.16).

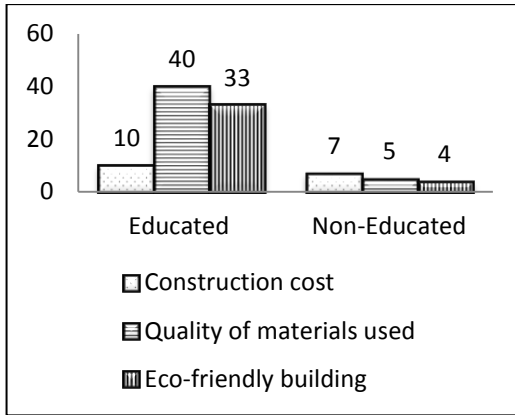

Figure 5.16: Question 10-Education Bar Chart

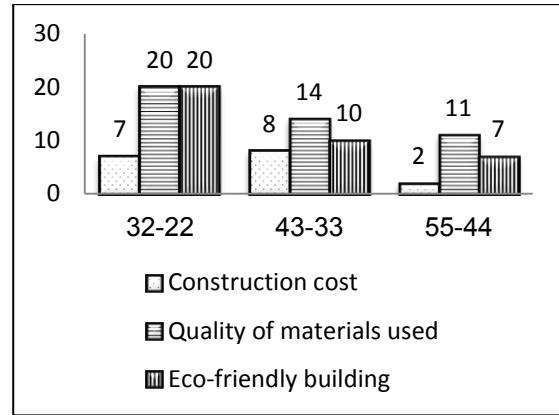

Figure 5.17: Question 10-Age Group Bar Chart

### 5.2.10 Question 11

The answer to this question confirms that 94% of people consider sustainable houses as expensive and they think it costs more than 35% as shown in figures 5.18 and 5.19 when compared to traditional ones.

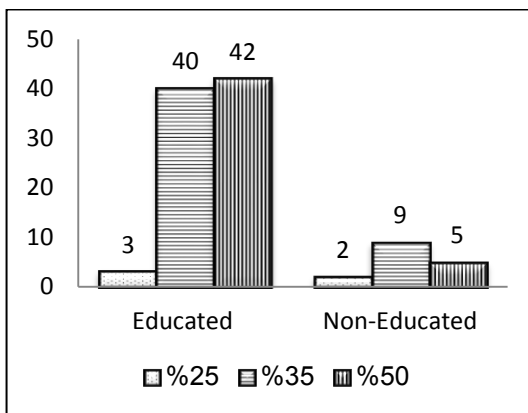

Figure 5.18: Question 11-Education Bar Chart

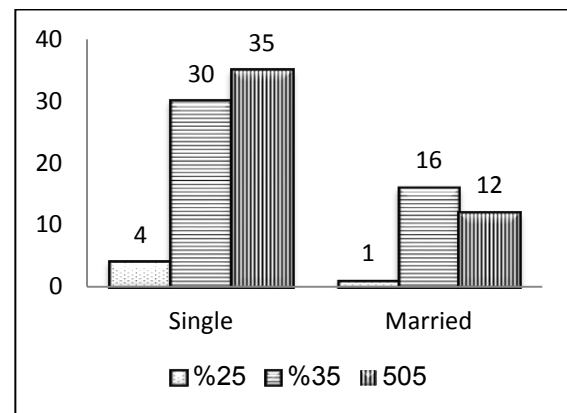

Figure 5.19: Question 11-Status Bar Chart

### 5.2.11 Question 12

The purpose of this question is to identify how much Lebanon's systems and organizations care about buildings. The results are 58 persons said No, however 43 said Yes. Actually there is one named "ARZ" certification founded from LGBC

(Lebanese Green Building Council). It is not well known because government did not support and offer facilities for green building.

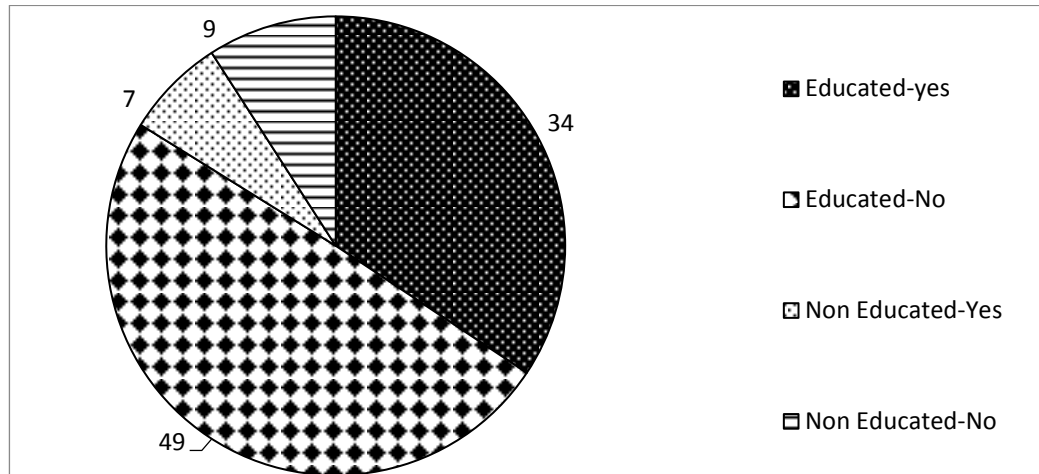

Figure 5.20: Question 12-Education Pie Chart

### 5.2.12 Question 13

According to the previous question and according to this one, 79% approve that Lebanon must provide some regulation to support companies for building sustainable structures.

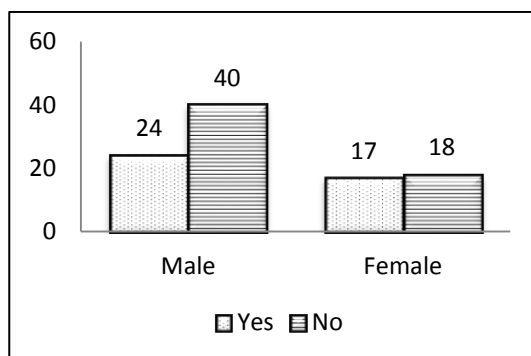

Figure 5.21: Question 13-Gender Bar Chart

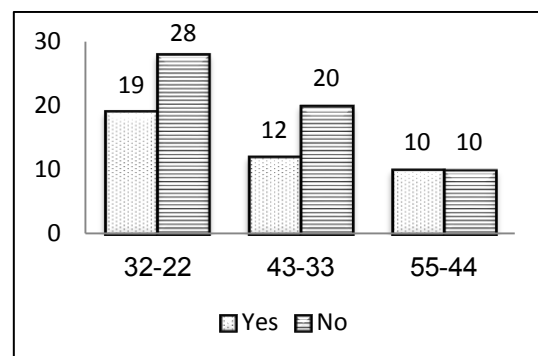

Figure 5.22: Question 13-Age Group Bar Chart

### 5.2.13 Question 14

70% of people consider Energy saving as the most significant for a Green building.

The educated ones are more aware about the energy saving as shown in figure 5.23

especially in Lebanon due to the absent of government electricity, it works just 10/24 hours/day.

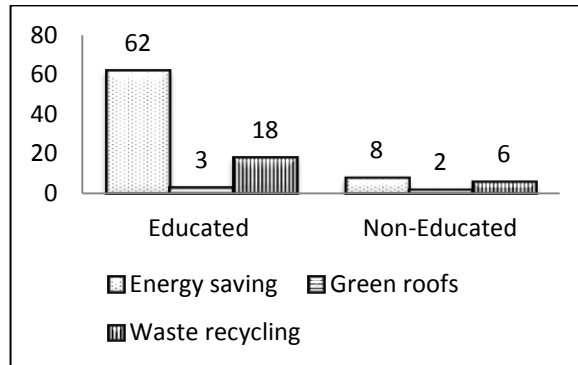

Figure 5.23 Question 14-Education Bar Chart

### 5.2.14 Question 15

Following the previous question, this question also focuses on the importance of the sustainable building toward the environment. By saving energy, sustainable architecture protects the environment at first. Secondly, the sustainable architecture is essential for civilization and its education and evolution (Figure 5.24).

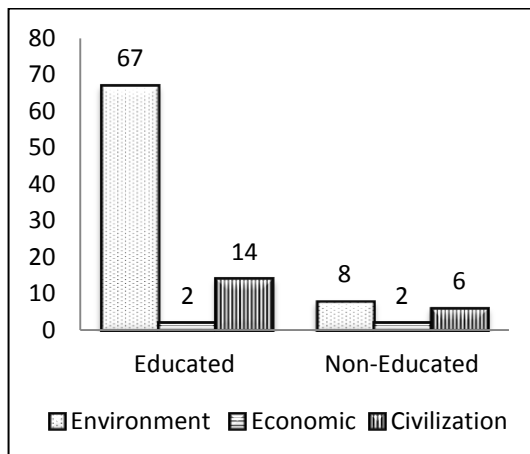

Figure 5.24: Question 15-Education Bar Chart

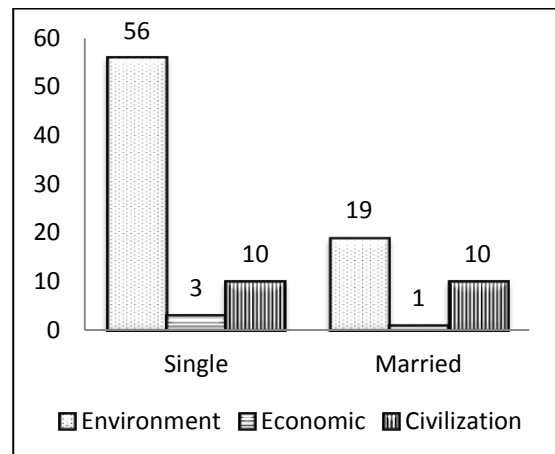

Figure 5.25: Question 15-Status Bar Chart

### 5.2.15 Question 16

Although 41% agree that sustainable housing construction will be developed reasonably fast in Lebanon, 58% disagree and they think this idea will need a long duration to be advanced. These results reveal that Lebanese people are still more attached to the traditional building and more time is required for them to accept a new way of building housing. Even the educated and the young people, as the new generation, they are also more interested in the traditional housing as shown in figure 5.27, however non-educated are not ready for a change of both culturally and economically, when housing is concerned.

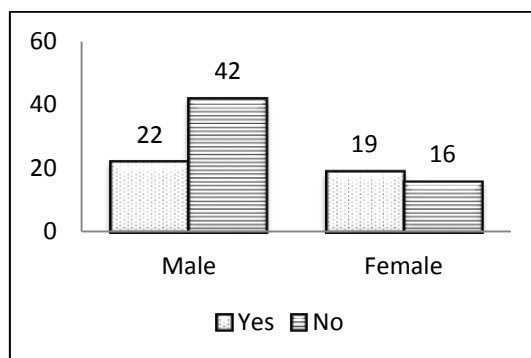

Figure 5.26: Question 16-Gender Bar Chart

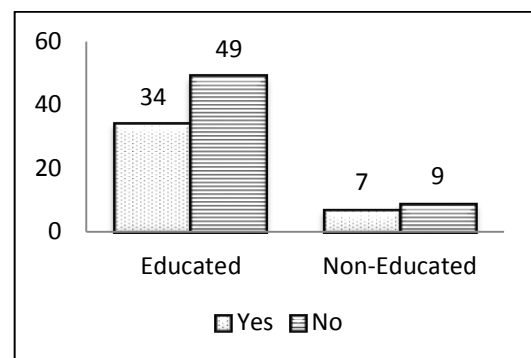

Figure 5.27: Question 16-Education Bar Chart

### 5.2.16 Question 17

The results in figure 5.28 defines that the education of the people is poor in this field. Most of them are not educated or trained enough to handle sustainable projects. Moreover, this deficit of knowledge is not specific to one group but rather it is valid for everyone.

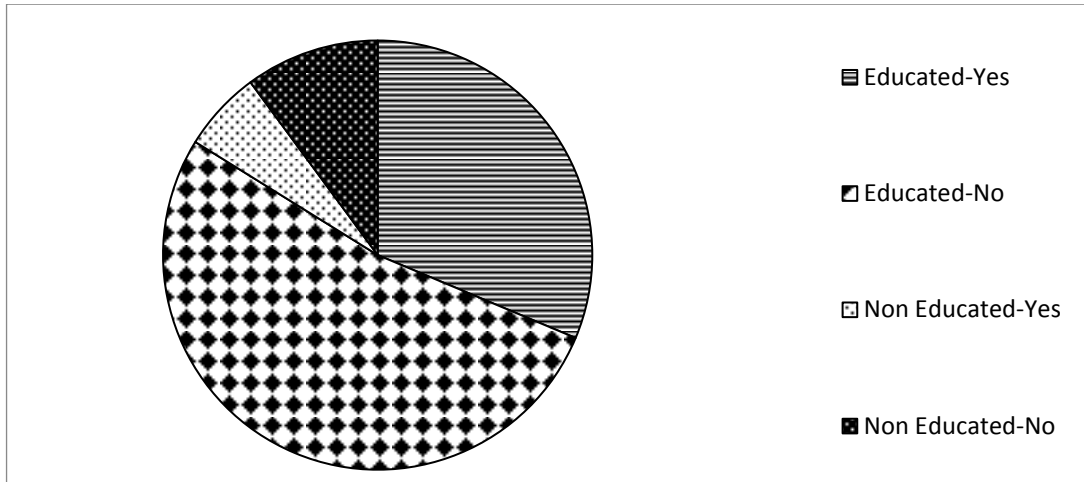

Figure 5.28: Question 17-Education Pie Chart

### 5.2.17 Question 18

The harmonization between the results estimates that people have in their minds some thoughts, interpretations, and theories about sustainable construction but they do not expose it in the right way (referring to the question number 17).

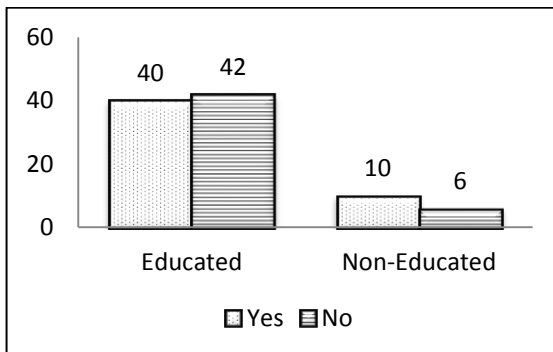

Figure 5.29: Question 18-Education Bar Chart

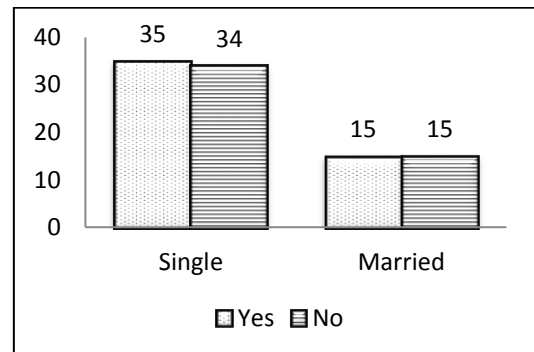

Figure 5.30: Question 18-Status Bar Chart

### 5.2.18 Question 19

The results confirm that since Lebanon is lacking the sustainable construction, there are no stocks of materials for sustainable constructions (Figure 5.31) . Therefore 67% of people answered this question according to their background and culture.

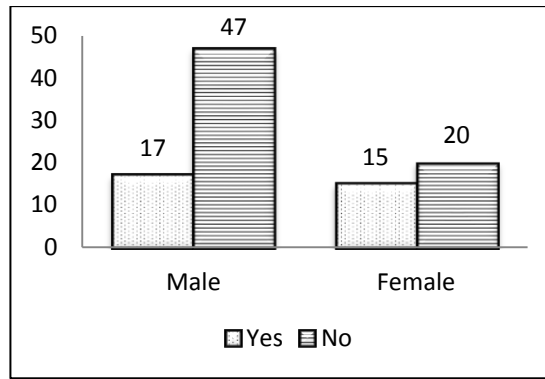

Figure 5.31: Question 19-Gender Bar Chart

### 5.3 Discussion of Survey Results

The survey results show that Green Building is becoming more familiar to Lebanese citizen, especially by the younger age group, 22-32. Moreover, the analysis indicates that Lebanese prefer to construct sustainable residential building rather than traditional one. Even though the respondents do not know about any standard in Lebanon, there is the ARZ certification which is not known by them due to the lack of advertisement. Besides, the results show that Lebanese people are aware of the benefits of Green Building construction and insist that the government must provide some laws and regulations to enhance this matter. Furthermore, the Lebanese government did not support this matter which can be proved by absence of initiatives and regulations to support ARZ certification. On the other hand, the Lebanese investors are using traditional residential construction method in order to gain the maximum profit without taking into consideration any green building feature. Thus, the government, public and citizen should be aware of green building benefits which can promote the Lebanese construction industry to a better position.



## Chapter 6

### CONCLUSION AND RECOMMENDATIONS

#### 6.1 Conclusion

Green buildings are the buildings of future. They hold a lot of potential for improving our way of living and saving the environment. There is no doubt that green buildings save a lot of energy and resources through the solar panels and lighting systems. Yet green buildings have a higher initial cost than traditional buildings. In Lebanon, green buildings are still in their early stages. Thus, it is important to have continuous research to improve the technologies which is not available in Lebanon due to the absence of awareness of the government, investors and public. Hence, the Lebanese Green Building Council is trying to promote green buildings through the “ARZ certification”. However, this certification remains symbolic despite existing plans to get financial support in the future from the government.

The Factory 4376 is currently at an early stage of its construction. It was used as a case study with consideration of BREEAM certification categories. The following are the conclusions from the case study:

- The application of green features has promoted the case study building to achieve a BREEAM "GOOD" classification ranging from 45% to 55%.

- The use of double glazing found to save energy with a 6 years break even period, which is considered as short duration.
- The application of LED lights has reduced the energy consumption and total cost by approximately 45% compared to the Fluorescent lamps.
- The implementation of solar panels for water heating also resulted in a reduction of energy consumption and cost by approximately 50% of the initial system using electric water heaters.

The following are the conclusions from the survey:

- The survey has shown a major lack of knowledge and awareness towards the advantages and features of green buildings.
- The younger age group from 22 to 32 is the group that is most interested in green building concept applications which assure a good future for this matter in Lebanon.
- The absence of conferences and cooperation between governmental and non-governmental organizations resulted in the lack of information of Lebanese people on the ARZ certification rating system..

## **6.2 Recommendations**

True initiatives are needed in order to promote for green buildings in Lebanon. One should keep in mind that key for any true development in this field is raising awareness towards the importance of sustainable construction through the following measures:

- The Lebanese NGOs should take responsibility by organizing conferences that reaches to different sections of the community.

- The government should provide more support through legislations and financial support for all green projects in the country by providing bank loans with lower interest rate.
- The investors willing to apply green building concepts in their project should have facilities, such as, ensuring that they will get the necessary materials and equipment with the best prices.

These measures along with the stimulation of the “ARZ certification program” can be considered as a great start that can put the country on the right track towards a sustainable future. Otherwise green buildings in Lebanon will be limited to those luxurious residential and commercial buildings.

### **6.3 Recommendations for future study:**

The following areas can be considered for further study in future:

- Investigation on construction waste, how it can be managed and recycled
- Pollution due to construction activities and products.
- Collecting data about the facilities and incentives given to investors by the government for their green building concepts.
- Preparing an inventory of green materials and equipment in Lebanese market.

## REFERENCES

- [1] Aguilar, A., Diola, N., & Orozco, C. Environmental Performance Assessment of Residential Green Technologies using Philippine Green Building Rating System. *University of Philippines Diliman*.
- [2] Bianchini, F., & Hewage, K. (2011). How “green” are the green roofs? Lifecycle analysis of green roofs materials. *Building and Environment*, 48, 57-65.
- [3] <http://www.ecohomeresource.com>
- [4] Blackhurst, M., Hendrickson, M., & Matthews, S. (2010). Cost-Effectiveness of Green [7] Roofs. *Journal of Architectural Engineering*, 136-143.
- [5] <http://www.singleply.co.uk>
- [6] <http://www.greenroofs.com>
- [7] Chaaban, F., & Rahman, S. (1998). Baseline energy and electricity consumptions in Lebanon and opportunities for conservation. *Energy Policy*, 26(6), 487-493
- [8] <http://www.architecture-view.com>
- [9] Howe, J. (2006). SUSTAINABLE DRAINAGE. *The Architects' Journal*, , 51-52, 54.

- [10] Scholz, M., (2006). Sustainable Urban Drainage System Model. *Elsevier Science and Technology*.
- [11] <http://water.epa.gov>
- [12] Abu Saleem M., Al-Ulayyan A., Assayed A., Azzam S., Bushnaq S., Hatokay R., Qbailat M., & Maroni R., (2013). On-site rainwater harvesting to achieve household water security among rural and peri-urban communities in Jordan. *Resources, Conservation and Recycling*, 73, 72-77.
- [13] <http://www.rainwindsun.com>
- [14] Morton, J. (2013). Go Green with Greywater. *Buildings*, 107(1), 24.
- [15] Ozener, O.A. (2014). Developing a Collaborative Planning Framework for Sustainable Transportation. Retrieved from <http://dx.doi.org/10.1155/2014/107102>
- [16] <http://olis.uoregon.edu>
- [17] Tumlin, J. (2011). The City of the Future. *John Wiley & Sons*.
- [18] <http://la.streetblog.org>
- [19] <http://www.greenoverdose.com>
- [20] <http://www.freemages.co.uk>

- [21] Lewis, R., Ryle, R., Sear, L., & Wainwright, P. Cementitious Additions. Retrieved from [www.knovel.com](http://www.knovel.com).
- [22] Amato, I. (2013). Concrete Solutions, *Nature*, 494, 301-302
- [23] <http://sk.wikipedia.org>
- [24] <http://www.wonderchem.com>
- [25] <http://www.waste-management-world.com>
- [26] Abu Saleem, M., Al-Ullyan, A., Assayed, A., Azzam, S., Bushnaq, S., Hatokay, Behera, M., Bhattacharyya, S. K., Deoliya, R., Maiti, S., & Minocha, A. K. (2014). Recycled aggregate from C&D waste & its use in concrete: A breakthrough towards sustainability in construction sector: A review. *Construction and Building Materials*, 502-514.
- [27] <http://www.haaretz.com>
- [28] <http://www.agg-net.com>
- [29] Timilsina, G.R., Kurdelashvidi, L., & Narbel, P.A. (2011). Solar energy: Markets, economics and policies. *Renewable and Sustainable Energy Reviews*, 16, 449– 465.
- [30] <http://www.sunpowercorp.co.uk>

- [31] <http://www.home-energy-saving-tips.com>
- [32] <http://www.EPA.gov>
- [33] Makdisi, S., & Sadaka, R. (2003). *The Lebanese Civil War, 1975-1990*. American University of Beirut.
- [34] Chaaban, F., & Rahman, S. (1998). Baseline energy and electricity consumptions in Lebanon and opportunities for conservation. *Energy Policy*, 26(6), 487-493
- [35] <http://www.behance.net>
- [36] <http://www.cement.com>
- [37] <http://www.brsslebanon.com>
- [38] <http://www.beirut.com>
- [39] <http://www.designboom.com>
- [40] Barlow, S. (n.d). Guide to BREEAM.
- [41] BREEAM International New Construction Technical Manual (2014). BRE Global Ltd. Retrieved from <http://www.breeam.org>.
- [42] <http://www.estates.com.lb>

- [43] <http://www.pmarchitects.com>
- [44] <http://www.archiexpo.com>
- [45] <http://www.bear-lb.com>
- [46] <http://www.designingyourperfecthouse.com>
- [47] <http://www.vrf-air-conditioning.co.uk>
- [48] <http://www.treehugger.com>
- [49] LED Lighting (n.d). Lebanon Green Building Council.
- [50] <http://www.greenrooftechnology.com>
- [51] <http://www.planetnatural.com>
- [52] Estimating the cost and energy efficiency of a solar water heater (2012).  
Retrieved from <http://energy.gov/energysaver/articles/estimating-cost-and-energy-efficiency-solar-water-heater>.
- [53] High Performance Glazing (n.d). Lebanon Green Building Council.
- [54] <http://alpsbeirut.wordpress.com>



- [55] Aashish, S., Abhishek, S., Muneesh, S., Venu, S., & Varun (2011). Life cycle assessment of buildings: A review. *Renewable and Sustainable Energy Reviews*
- [56] Paint (n.d). Lebanon Green Building Council.
- [57] <http://www.sico.ca>
- [58] Chaaban, F., & Rahman, S. (1998). Baseline energy and electricity consumptions in Lebanon and opportunities for conservation. *Energy Policy*, 26(6), 487-493.
- [59] Hourri, A. (2006). Solar water heating in Lebanon: Current status and future prospects. *Renewable Energy*, 663-675

## **APPENDICES**

## Appendix A: Questionnaires

**Note:** This survey is being carried out as part of a Master's thesis currently prepared to be submitted to Civil Engineering Department, Eastern Mediterranean University. The results of the survey given in Appendix B will be analysed and reported in the mentioned thesis.

1. Do you know what "Green Building" is?	YES	NO
2. Have you hear about "ARZ certification" in Lebanon?	YES	NO
3. Do you know the differences between traditional and sustainable houses	YES	NO
4. Do you desire to live in a sustainable building rather than a traditional one?	YES	NO
5. Do you afford to buy a green house which may cost more than a traditional house?	YES	NO
6. Do you prefer to construct a traditional or a sustainable residential building on your land?		
7. Do you know any sustainable residential building in Lebanon?	YES	NO
8. Do you recognize what kinds of construction materials are used in "Green Building"? A) Stone B) Steel C) Reinforced concrete		
9. Which one of these building in Lebanon is a "GREEN Building"? A) Beirut Sky centre		

B) Marina Centre C) Melenio Centre		
10. What differentiates a traditional house from sustainable one? A) Construction Cost B) Quality of materials used C) Eco-friendly building		
11. In your opinion what is the percentage difference in cost of a sustainable house compared to a traditional one?  A) 25% B) 35% C) 50%		
12. Do you know if there are standards and nongovernmental organizations that rate buildings in Lebanon?	YES	NO
13. Do you agree that the government must provide some regulations to support and persuade companies to build sustainable buildings rather than traditional ones?	YES	NO
14. Which item is the most significant for a "Green Building"? A) Energy saving B) Green roofs C) Waste recycling	YES	NO
15. Sustainable building is most important for A) Environment B) Economic C) Civilization		
16. Do you think sustainable housing construction will spread in a fast manner in Lebanon?	YES	NO
17. Do you think your employees are knowledgeable and trained to handle sustainable projects?	YES	NO
18. Do you know what construction industry workers at different levels need to know and be able to apply for sustainable construction?	YES	NO
19. Do you think Lebanese construction material suppliers keep stock of materials for sustainable construction?	YES	NO

## Appendix B: Tables of Survey

❖ Questions:	YES	NO
1. Do you know what "Green Building" is?	81	18
❖ Gender:		
○ Male	56	8
○ Female	25	10
❖ Age:		
○ 22-32	39	8
○ 33-43	24	8
○ 44-55	18	2
❖ Education		
○ Educated	69	14
○ Non-Educated	12	4
❖ Status		
○ Single	54	15
○ Married	27	3
❖ Nationality		
○ Lebanese	73	14
○ Others	8	4

❖ Questions:	YES	NO
2 Did you hear about "ARZ certification" in Lebanon?	17	82
❖ Gender:		
○ Male	7	57
○ Female	10	25
❖ Age:		
○ 22-32	8	39
○ 33-43	8	24
○ 44-55	1	19
❖ Education		
○ Educated	14	69
○ Non-Educated	5	11
❖ Status		
○ Single	14	73
○ Married	3	9
❖ Nationality		
○ Lebanese	15	54
○ Others	2	28

❖ Questions:	YES	NO
3. Do you know what the difference between traditional and sustainable house is?	80	19
❖ Gender:		
○ Male	60	4
○ Female	20	15
❖ Age:		
○ 22-32	38	9
○ 33-43	24	8
○ 44-55	18	2
❖ Education		
○ Educated	76	4
○ Non-Educated	4	11
❖ Status		
○ Single	52	17
○ Married	28	2
❖ Nationality		
○ Lebanese	73	14
○ Others	7	5

❖ Questions:	YES	NO
4. Do you desire to live in a sustainable building rather than regular one?	80	19
❖ Gender:		
○ Male	40	24
○ Female	18	17
❖ Age:		
○ 22-32	28	19
○ 33-43	20	12
○ 44-55	10	10
❖ Education		
○ Educated	49	34
○ Non-Educated	9	7
❖ Status		
○ Single	50	19
○ Married	8	22
❖ Nationality		
○ Lebanese	53	34
○ Others	5	7



❖ Questions:	YES	NO
5. Do you afford to buy a greenhouse which cost more than regular houses?	39	60
❖ Gender:		
○ Male	19	45
○ Female	20	15
❖ Age:		
○ 22-32	16	31
○ 33-43	17	15
○ 44-55	6	14
❖ Education		
○ Educated	33	50
○ Non-Educated	6	10
❖ Status		
○ Single	19	50
○ Married	20	10
❖ Nationality		
○ Lebanese	29	58
○ Others	10	2

❖ Questions:	YES	NO
6. Will you prefer to construct on your land: Traditional residential building or sustainable residential building?	66	33
❖ Gender:		
○ Male	49	15
○ Female	17	18
❖ Age:		
○ 22-32	26	21
○ 33-43	24	8
○ 44-55	16	4
❖ Education		
○ Educated	53	30
○ Non-Educated	13	3
❖ Status		
○ Single	44	25
○ Married	22	8
❖ Nationality		
○ Lebanese	59	28
○ Others	7	5

❖ Questions:	YES	NO
7. Do you know any sustainable residential building in Lebanon	50	49
❖ Gender:		
○ Male	30	34
○ Female	20	15
❖ Age:		
○ 22-32	20	35
○ 33-43	14	10
○ 44-55	16	4
❖ Education		
○ Educated	40	43
○ Non-Educated	10	6
❖ Status		
○ Single	35	34
○ Married	15	15
❖ Nationality		
○ Lebanese	44	43
○ Others	6	6

❖ Questions:	Stone	Steel	Reinforced concrete
8. Do you recognize what kinds of construction materials are used in "Green Building"?	38	38	23
❖ Gender:			
○ Male	26	25	13
○ Female	12	13	10
❖ Age:			
○ 22-32	20	24	11
○ 33-43	10	6	8
○ 44-55	8	8	4
❖ Education			
○ Educated	30	33	20
○ Non-Educated	8	5	3
❖ Status			
○ Single	20	29	20
○ Married	18	8	3
❖ Nationality			
○ Lebanese	33	34	20
○ Others	5	4	3

❖ Questions:	Beirut Sky center	Marina center	Melenio Center
9. Which one of these building in Lebanon is a "Green Building"?	30	26	43
❖ Gender:			
○ Male	20	25	19
○ Female	10	11	14
❖ Age:			
○ 22-32	15	16	24
○ 33-43	10	4	10
○ 44-55	5	6	9
❖ Education			
○ Educated	24	21	38
○ Non-Educated	6	5	5
❖ Status			
○ Single	20	18	31
○ Married	10	8	12
❖ Nationality			
○ Lebanese	26	23	38
○ Others	4	3	5

❖ Questions:	Construction Cost	Quality of Materials used	Eco-friendly Building
10. What differentiates traditional house from sustainable one?	17	45	37
❖ Gender:			
○ Male	10	31	23
○ Female	7	14	14
❖ Age:			
○ 22-32	7	20	20
○ 33-43	8	14	10
○ 44-55	2	11	7
❖ Education			
○ Educated	10	40	33
○ Non-Educated	7	5	4
❖ Status			
○ Single	10	34	25
○ Married	7	11	12
❖ Nationality			
○ Lebanese	15	40	32
○ Others	2	5	5

❖ Questions:	25%	35%	50%
11. In your opinion what is the percentage difference in cost of a sustainable house compared to a traditional one?	5	47	47
❖ Gender:			
○ Male	3	30	31
○ Female	2	17	16
❖ Age:			
○ 22-32	0	17	30
○ 33-43	3	19	10
○ 44-55	2	11	7
❖ Education			
○ Educated	3	40	42
○ Non-Educated	2	9	5
❖ Status			
○ Single	4	30	35
○ Married	1	16	12
❖ Nationality			
○ Lebanese	5	40	42
○ Others	0	7	5

❖ Questions:	YES	NO
12..Do you know if there are standards and nongovernmental organizations that rate buildings in Lebanon	41	58
❖ Gender:		
○ Male	24	40
○ Female	17	18
❖ Age:		
○ 22-32	19	28
○ 33-43	12	20
○ 44-55	10	10
❖ Education		
○ Educated	34	49
○ Non-Educated	7	9



❖ Questions:	YES	NO
13. Do you agree that the government must provide some regulations to support and persuade companies to build sustainable buildings rather than traditional ones?	79	20
❖ Gender:		
○ Male	59	5
○ Female	20	15
❖ Age:		
○ 22-32	37	10
○ 33-43	24	8
○ 44-55	18	2
❖ Education		
○ Educated	75	5
○ Non-Educated	4	11

❖ Questions:	Energy saving	Green roofs	Waste recycling
14. Which item is the most significant for a "Green Building", Energy saving or Green roofs or Waste recycling?	70	5	24
❖ Gender:			
○ Male	44	3	17
○ Female	26	2	7
❖ Age:			
○ 22-32	37	0	10
○ 33-43	21	3	8
○ 44-55	12	2	6
❖ Education			
○ Educated	62	3	18
○ Non-Educated	8	2	6

❖ Questions:	Environment	Economic	Civilization
15. Sustainable building is most important for? Environment or Economic or Civilization	75	4	20
❖ Gender:			
○ Male	49	2	13
○ Female	26	2	7
❖ Age:			
○ 22-32	37	0	10
○ 33-43	26	2	4
○ 44-55	12	2	6
❖ Education			
○ Educated	67	2	14
○ Non-Educated	8	2	6
❖ Status			
○ Single	56	3	10
○ Married	19	1	10
❖ Nationality			
○ Lebanese	69	4	15
○ Others	7	0	5

❖ Questions:	YES	NO
16. Do you think sustainable housing construction will spend in a fast manner in Lebanon	41	58
❖ Gender:		
○ Male	22	42
○ Female	19	16
❖ Age:		
○ 22-32	18	29
○ 33-43	13	19
○ 44-55	10	10
❖ Education		
○ Educated	34	49
○ Non-Educated	7	9

❖ Questions:	YES	NO
17. Do you think your employees are knowledgeable and trained to handle sustainable projects?	37	62
❖ Gender:		
○ Male	17	47
○ Female	20	15
❖ Age:		
○ 22-32	14	32
○ 33-43	17	15
○ 44-55	6	14
❖ Education		
○ Educated	31	52
○ Non-Educated	6	10

❖ Questions:	YES	NO
18. Do you know what construction industry workers at different levels need to know and be able to apply for sustainable construction?	50	49
❖ Gender:		
○ Male	30	34
○ Female	20	15
❖ Age:		
○ 22-32	20	35
○ 33-43	14	10
○ 44-55	16	4
❖ Education		
○ Educated	40	43
○ Non-Educated	10	6
❖ Status		
○ Single	35	34
○ Married	15	15
❖ Nationality		
○ Lebanese	44	43
○ Others	6	6

❖ Questions:	YES	NO
19. Do you think Lebanese construction material suppliers keep stock of materials for sustainable construction?	32	67
❖ Gender:		
○ Male	17	47
○ Female	15	20
❖ Age:		
○ 22-32	13	34
○ 33-43	14	18
○ 44-55	5	15