

# **A Systematic Analysis of Formative Design Ideas of Zaha Hadid**

**Ameen Mokhles Youns**

Submitted to the  
Institute of Graduate Studies and Research  
in partial fulfillment of the requirements for the degree of

Master of Science  
in  
Architecture

Eastern Mediterranean University  
July 2017  
Gazimağusa, North Cyprus

Approval of the Institute of Graduate Studies and Research

---

Prof. Dr. Mustafa Tümer  
Director

I certify that this thesis satisfies the requirements as a thesis for the degree of Master of Science in Architecture.

---

Prof. Dr. Naciye Doratli  
Chair, Department of Architecture

We certify that we have read this thesis and that in our opinion it is fully adequate in scope and quality as a thesis for the degree of Master of Science in Architecture.

---

Prof. Dr. Hifsye Pulhan  
Supervisor

---

Examining Committee

1. Prof. Dr. Hifsye Pulhan

2. Assoc. Prof. Dr. Rafooneh M. Sani

3. Asst. Prof. Dr. Badiossadat Hassanpour

## **ABSTRACT**

The iconic architecture has an imperative role in making image of modern urban communities. Looking through Zaha Mohammad Hadid's architectural works, one can see a large variety of iconic buildings regarding their architectural forms and notions to the degree that some doubt shrouds the possibility of specifying the outstanding aspects of her iconic buildings, how Zaha Hadid could produce such iconic architecture, and how her buildings are influential in the field of architecture. Hadid is one of this era's well-known architects who have contributed to conceive the architectural form and space from a new, innovative, and futuristic perspective. The iconicity embodied by Hadid's projects is rooted in contradiction. The paradox between ideas in the formative stages serves to integrate the processes of conceiving and implementing innovative and rational architecture. Despite her great influence in the new generation of architects and architectural students around the world, there is a lack of systematic research on her architectural approaches. In this sense, this study attempts to understand design approaches of Zaha Hadid by analyzing her most well-known projects. The selected individual cases passed through different analytical criterion which are basically design idea generated, form patterns created and the design techniques used, so as to enforcing the iconicity of her works. Through a literature survey, Zaha Hadid's design techniques and form patterns are thoroughly searched in order to provide a theoretical and conceptual framework to the study as well as a base to the analysis of the selected cases. Then formative design ideas are discussed and documented by means of specially developed analytical diagrams. Under this scope, it is can be stated that Hadid often works within the framework of personally-developed design techniques and creates certain form patterns

communicating her formative design ideas. The architectural forms which are generally abstract, fragmented, fluent, layered, interacted with landscape, defying gravity or enchanting with the play of light and masses are the indications of a new way of design thinking and production in the field of Architecture. In fact, this is the architecture that expresses the understanding of Zaha Hadid that never ignores and excludes the changing views, realms and circumstances of the contemporary world.

**Keywords:** Zaha Hadid, Architectural Design, Form Patterns, Design Techniques, Formative Design Ideas.



## ÖZ

İkonik mimari, modern kent toplumlarının imaj oluşumunda gerekli bir role sahiptir. Zaha Muhammed Hadid'in mimari eserlerine bakılacak olursa, benzersiz binalarının olağanüstü yönlerini kuşkusuz belirleme imkânını, mimari formlarına ve kavramlarına ilişkin çok çeşitli ikonik yapılar olduğunu, ve Zaha Hadid'in böylesi bir ikonik mimariyi nasıl üretebildiğini, üretilen yapıların Mimarlık alanında nasıl bu kadar etkili olabildiğini görmek mümkündür. Hadid, mimari formu ve mekanı yenilikçi ve fütüristik bir perspektiften algılamaya katkıda bulunmuş bu çağın en tanınmış mimarlarından biri olmuştur. Hadid projelerinde somutlaşan ikonikliğin temelini çelişkiye dayandırmıştır. Oluşum sürecinde Zaha Hadid'in fikirleri arasındaki paradoks, yenilikçi ve rasyonel mimarisinin tasarlama ve uygulama süreçlerini bütünleştirmesine yaramıştır. Ancak, yeni nesil mimarların gelişiminde ve tüm dünyadaki mimarlık öğrencileri üzerinde bu kadar etkili olmuş olan Zaha Hadid'in mimari yaklaşımları üzerine gerekli ve yeterli sayıda sistematik araştırma yapılmamıştır. Bu bağlamda, mevcut çalışma, Zaha Hadid'in tasarım yaklaşımlarını, en tanınmış mimari eserlerini sistematik bir şekilde inceleyerek anlamayı hedeflemektedir. Seçilmiş olan tekil bina örneklerinin, geliştirilen tasarım düşüncelerine, biçimsel modellerine ve tasarım tekniklerine yönelik yapılan incelemeleri ile, Zaha Hadid binalarının ikonismi değerlendirilmektedir. Çalışmanın kuramsal ve kavramsal çerçevesini çizmek ve sistematik incelemeye bir temel oluşturmak üzere, literatür taraması ile Zaha Hadid'in tasarım teknikleri ve biçimsel modelleri bütünlüklü olarak araştırılmıştır. Daha sonra, Biçimsel Tasarım Fikirleri, seçilmiş olan tekil binalar örnekleri üzerinden, geliştirilmiş olan analitik şemalar kullanılarak, incelenip tartışılmış ve belgelenmişlerdir. Bu kapsamda, Hadid'in kişisel

olarak geliřtirdiđi tasarım teknikleri çerçevesinde çalıřtıđı ve biçimsel tasarım fikirlerinin ifade edildiđi belli biçimsel modeller geliřtirdiđi söylenebilir. Genellikle, soyut, parçalalı, akıřkan, katmanlı, peyzaj ile etkileřmiř, yerçekimine meydan okuyan, ya da ıřık-gölge oyunları ile büyülecı bir hal alan eserleri, Mimarlık alanında, yeni bir tasarım düşüncesinin ve ürününün göstergesi olmuřtur. Aslında sözkonusu olan bu mimari, günümüz dünyasının deđiřen görüř, kořul ve gerçeklerini gözardı etmeyen Zaha Hadid anlayıřının bir yansıması olarak nitelendirilebilir.

**Anahtar Kelimeler:** Zaha Hadid, mimari tasarım, biçimsel modeller, tasarım teknikleri, biçimsel tasarım fikirleri.

# DEDICATION

I dedicate this humble effort:

- To my dear mother and father, whose kindness has kept me,
- To my sisters, brothers, and others who inhabit my heart,
- To the guide of my way, my dear supervisor.

## ACKNOWLEDGMENT

“In the Name of God, Most Gracious and Most Merciful”

First, I would like to extend my sincere gratitude to my thesis Supervisor, Prof. Dr. Hifsiye Pulhan and thank her for understanding, advising and encouraging me throughout the process of writing this thesis, I am indeed grateful.

I wish to express my thanks to my parents, who have encouraged and supported me in all my endeavors, and the other members of my family, my beloved sisters Zeyneb and Huda, also my great brothers and role models in life, Mustafa and Muhammed, thanks from the deepest part of my soul.

To my friends in Cyprus who are now like a second family, I would like to express my gratitude; particularly to my best friends Zanyar Omer, Rawand Amin, Mohammed Siyamand, Zhya Sherwani and other beloved friends in the dormitory for their support and continuous interest in my progress. With all their help, they kept me calm, made me laugh, and gave me the self-confidence to finish the thesis.

I should express many thanks to the faculty members of the architecture Department, especially for Assoc. Prof. Dr. Rafooneh M. Sani and Assist. Prof. Dr. Badiossadat Hassanpour.

*Ameen M. Youns*

# TABLE OF CONTENTS

ABSTRACT .....	iii
ÖZ .....	v
DEDICATION .....	vii
ACKNOWLEDGMENT .....	viii
LIST OF FIGURES .....	xi
LIST OF TABLES .....	xvi
1 INTRODUCTION .....	1
1.1 Problem Statement .....	3
1.2 Aim and Objectives of the Study .....	3
1.3 Limitation of the Study .....	4
1.4 Research Methodology.....	4
2 PROFESSIONAL BACKGROUND AND DESIGN DISCOURSE OF ZAHA HADID .....	6
2.1 The architecture of Zaha Hadid.....	6
2.1.1 Professional Development and Concerns of Zaha Hadid .....	6
2.1.2 Zaha Hadid and Deconstructivism .....	10
2.1.3 Contemporaries and Criticism of Zaha Hadid .....	17
2.1.4 Iconicity and Zaha Hadid Architecture .....	21
2.2 Techniques of Design in Zaha Hadid Architecture.....	26
2.2.1 Abstraction and Fragmentation .....	26
2.2.2 Idea of Ground and Gravity .....	29
2.2.3 Landscaping the Surroundings .....	30
2.2.4 Layering .....	31

2.2.5	Play of Light.....	33
2.2.6	Seamlessness and Fluidity .....	34
2.3	Patterns of Form in Zaha Hadid Architecture .....	35
2.3.1	Suprematist Forms .....	36
2.3.2	Topographic Forms .....	37
2.3.3	Fluid Form.....	38
2.3.4	Organic Form .....	40
2.3.5	Parametric Form.....	42
2.4	Formative design ideas in Zaha Hadid Architecture.....	45
3	ANALYSIS OF ZAHA HADID ARCHITECTURE .....	50
3.1	Method for analysis of Zaha Hadid Architecture.....	50
3.2	Criteria for the selection of Cases .....	52
3.3	Analysis of the selected Buildings .....	55
3.3.1	Heydar Aliyev Cultural Center, Baku, 2012.....	55
3.3.2	Dongdaemun Design Plaza, Seoul, 2013 .....	64
3.3.3	Library and Learning Center, Vienna, 2012 .....	71
3.3.4	Galaxy SoHo, Beijing, 2012 .....	78
3.3.5	Innovation Tower; Jockey Club, Hong Kong, 2014 .....	86
3.3.6	MAXXI Museum of XXI century Arts, Rome, 2009 .....	93
3.3.7	Vitra Fire Station, Weilam Rhein, Germany, 1993.....	102
4	FINDINGS AND DISCUSSION.....	109
5	CONCLUSION.....	126
	REFERENCES.....	129

## LIST OF FIGURES

Figure 1: Structure of the study in this research .....	5
Figure 2: Zaha Mohammad Hadid. Source: <a href="https://www.dezeen.com">https://www.dezeen.com</a> .....	7
Figure 3: The Peak Leisure Club, Zaha Hadid, 1983.....	8
Figure 4: Vitra Fire Station in Weil-am-Rhein, Germany, 1993. ....	9
Figure 5: a) Suprematist project by Yakov Chernikhov featured by anti-gravity and using pure Geometrical forms, in early 1920.....	14
Figure 6: Abstract Painting Presented in 2D pure geometrical forms by Malevich. (Source @ <a href="http://lightinthebox.com">lightinthebox.com</a> ) .....	15
Figure 7: a) Seagram Building, Mies van der Rohe, 1958. b) Falling water, Frank Lloyd Wright, 1935. c) Notre Dame du Haut is a chapel in Ron champ, Le Corbusier, 1954. Source (L. Sklair, 2008).....	24
Figure 8: Mass cantilevering and porosity with the idea of ground and gravity.....	30
Figure 9: Landscaping the roof in Dongdaemun Design Plaza, South Korea, 2013. Source (Source: <a href="https://www.flickr.com">https://www.flickr.com</a> ) .....	31
Figure 10: forming the project in the current urban grid in Maxxi: National Museum, Rome, Italy, 2009. (Source: <a href="http://www.zaha-hadid.com">http://www.zaha-hadid.com</a> ) .....	31
Figure 11: Generating fluid space through layering, Museum for the Royal Collection Madrid, Spain (1999). (Source: Abdullah, 2013) .....	32
Figure 12: Space creation through layering manipulation in Darat King Abdullah Art Cultural Center in Amman, Jordan (2008). (Source: Abdullah, 2013).....	33
Figure 13: a) Overlapping & Interweaving. b) Accumulation. c) Juxtaposition. d) Fragmentation. (Source: Abdullah, 2013).....	34

Figure 14: seamlessness of the surface in Heydar Aliyev Cultural center, Azerbaijan 2007 – 2012 (Source: <a href="http://www.zaha-hadid.com">http://www.zaha-hadid.com</a> ) .....	35
Figure 15: The suprematist form of The Peak in Hong Kong (1982-83). Source: <a href="http://www.zaha-hadid.com">http://www.zaha-hadid.com</a> .....	37
Figure 16: The topographic form of Landesgartenschau 1999 in Weil am, Germany (1996-99) Source: <a href="http://www.zaha-hadid.com">http://www.zaha-hadid.com</a> .....	38
Figure 17: a) The fluid form of High-Speed Train Station etc. b) The fluid form of Guggenheim Museum Taichung in Taichung, Taiwan. (2003) Source: <a href="http://www.zaha-hadid.com">http://www.zaha-hadid.com</a> .....	40
Figure 18: a) The organic form of Maldives Luxury Resort, Munandhua, and Island, Maldives, 2007. Source: The complete Zaha Hadid. B) The organic form of Golf and spa resort, Dubrovnik, Croatia, 2009. Source: <a href="http://www.zaha-hadid.com">http://www.zaha-hadid.com</a> .....	41
Figure 19: The parametric design of Kartal-Pendik master plan in Istanbul, Turkey Source: <a href="http://www.zaha-hadid.com">www.zaha-hadid.com</a> .....	43
Figure 20: Illustration of Form patterns in Zaha Hadid Architecture. Source: Author based on (Abdullah A. 2013) .....	44
Figure 21: Massing in three famous buildings (Clark & Pause, 2005).....	46
Figure 22: The three conditions of conceiving balance; (a) symmetry... Source: Integrated Strategies in Architecture, 2006.....	46
Figure 23: The five types of formal relationship between plan and section or elevation. Sources: Clark & Pause, 2005.....	47
Figure 24: three geometrical types of quadric surface (Tomlow, 1989).....	49
Figure 25: general view which illustrates landscaping techniques in HACC. Source: <a href="http://www.zaha-hadid.com">http://www.zaha-hadid.com</a> .....	56



Figure 26: the seamlessness and fluidity of Heydar Aliyev Cultural Center. Source: <a href="http://www.zaha-hadid.com">http://www.zaha-hadid.com</a> .....	56
Figure 27: South-East elevation of Heydar Aliyev center illustrates the melting techniquev .....	57
Figure 28: views from the interior of HACC shows both techniques Source: <a href="http://www.zaha-hadid.com">http://www.zaha-hadid.com</a> .....	58
Figure 29: layered curved volumes are clad in pristine, white tiles in Heydar Aliyev Museum Source: <a href="http://www.zaha-hadid.com">http://www.zaha-hadid.com</a> .....	58
Figure 30: The integration of pavement and wall in Heydar Aliyev Culture Source: <a href="http://www.zaha-hadid.com">http://www.zaha-hadid.com</a> .....	59
Figure 31: The bird eye view of DDP. Source: <a href="http://www.zaha-hadid.com">http://www.zaha-hadid.com</a> .....	64
Figure 32: details of the plaza illustrated the melting technique. Source: <a href="http://www.zaha-hadid.com">http://www.zaha-hadid.com</a> .....	65
Figure 33: the figure illustrates the landscaping as a design technique. Source: <a href="http://www.zaha-hadid.com">http://www.zaha-hadid.com</a> .....	65
Figure 34: Dongdaemun design plaza, main entrance views, and differences from day and night through play of light technique. Source: <a href="http://www.zaha-hadid.com">http://www.zaha-hadid.com</a> .....	66
Figure 35: views from LLC, the inclination degree in perspective view in which tilted up to 35 degrees. Source: Dezeen .....	71
Figure 36: longitudinal section of LLC illustrates the inclined walls, mass cantilever and multistory atrium. Source <a href="http://www.zaha-hadid.com">http://www.zaha-hadid.com</a> .....	72
Figure 37: Night perspective view of LLC building, Accumulation or Superposition techniques used. Source <a href="http://www.zaha-hadid.com">http://www.zaha-hadid.com</a> .....	72
Figure 38: Interior views of LLC illustrates the relationship between the interior and exterior designs. Source <a href="http://www.zaha-hadid.com">http://www.zaha-hadid.com</a> .....	73

Figure 39: Birds eye view of LLC project. Source <a href="http://www.zaha-hadid.com">http://www.zaha-hadid.com</a> .....	74
Figure 40: night view of galaxy SoHo illustrates the play of masses technique. Source: <a href="http://www.zaha-hadid.com">http://www.zaha-hadid.com</a> .....	78
Figure 41: the layering technique through shifting and moving plateaus. source: <a href="http://www.skyscrapercity.com">http://www.skyscrapercity.com</a> .....	79
Figure 42: a view of Galaxy SoHo shows the fluid connection between the bridge and elliptical forms. Source: <a href="http://zyn-e.blogspot.com.cy/2014/05/">http://zyn-e.blogspot.com.cy/2014/05/</a> .....	80
Figure 43: The inner courtyard and leveling of Galaxy SoHo shows the strong connection between... Source: <a href="http://www.archdaily.com">http://www.archdaily.com</a> .....	81
Figure 44: eye level perspective of JCIT, shows the fluid and seamless details of the project. Source: <a href="http://www.archdaily.com">http://www.archdaily.com</a> .....	86
Figure 45: A render of the covering layer which used as shading design of JCIT Source: <a href="http://www.arch2o.com">http://www.arch2o.com</a> .....	87
Figure 46: A drawings of JCIT illustrates the horizontal fins that stretches alongside the building Source: <a href="https://www.dezeen.com">https://www.dezeen.com</a> .....	87
Figure 47 different views from the interior of the project give the same sense of the exterior of the building Source: <a href="http://www.archdaily.com">http://www.archdaily.com</a> .....	88
Figure 48: Bird eye view of Jockey Club innovation tower Source: <a href="http://worldarchitecture.org">http://worldarchitecture.org</a> .....	89
Figure 49: general view showing the different levels and layering technique in Maxxi Museum project Source: Hadid, 2009.....	94
Figure 50: Maxxi Museum illustrating the deep cantilever used as a technique. Source: <a href="http://www.architecturalrecord.com">http://www.architecturalrecord.com</a> .....	94
Figure 51: a view shows the straight masses changes to curved masses seamlessly Source: <a href="http://www.archdaily.com">http://www.archdaily.com</a> .....	95

Figure 52: generation a flow of masses by play of light technique Source: http://www.archdaily.com.....	96
Figure 53: the interior of Maxxi museum reflects the exterior form of flowing the masses. Source: http://www.archdaily.com .....	96
Figure 54: Birds eye view of Maxxi museum project showing the parallel masses distributed in the site properly. Source: http://www.archdaily.com .....	97
Figure 55: Vitra fire station: the idea of abstraction and fragmentation through collision Source: Zaha 2009 .....	103
Figure 56: illustration of Vitra fire station from the top view Source: author .....	103
Figure 57: Night view of Vitra fire station Source: https://www.architectural- review.com .....	104
Figure 58: the strong relationship between the exterior and interior of Vitra fire station Source: https://deavita.com/ .....	104

## LIST OF TABLES

Table 1: Abstraction and fragmentation Techniques by Hadid. Source: Author by basing on Abdullah (2013).....	28
Table 2: Chosen case studies according to the selection criteria's. Source: by Author .....	53
Table 3: Graphic language developed for analysis of formative ideas. Source: author .....	54
Table 4: Design approaches of Zaha Hadid in term of patterns of form and design techniques.....	118
Table 5: Formative design ideas of Zaha Hadid Architecture .....	119
Table 6: Massing of the selected buildings .....	120
Table 7: Symmetry & Balance in the selected buildings .....	121
Table 8: Relationships of a plan to section in the selected buildings.....	122
Table 9: Geometry in the selected buildings.....	123
Table 10: Repetitive to unique in the selected buildings .....	124
Table 11: Illustration of formative Design ideas in the selected buildings of Zaha Hadid .....	125

# Chapter 1

## INTRODUCTION

Considered to be an existential foothold, examples of iconic architecture are at the forefront in many of the world's cities. These buildings tend to be the physical manifestation of the same particular place characteristics that underscore the creation and design phases in an effort to ensure it radiates the iconicity of its particular location. Buildings which come to be identified with specific places are understood to be iconic buildings and serve to benefit society at large in addition to professionals. The stunning designs used in these buildings, in conjunction with their particular placement and contribution to their surrounding areas emit the energy and life they surpass. Technological advancements, particularly computer programs, have caused a shift in many sectors, including architecture. The human mind has become more imaginative and sophisticated in response to the anarchic mode of thinking dominant in present times by looking to develop more innovative ideas. This shift is reflected in the works of some practicing architects and the architectural students' projects.

Zaha Hadid as one of the most well-known pioneer in deconstructivist and her designs are the concern of this study. Her projects are characterized by fragmentation and abstraction, however, the idea behind her architecture lies in an in-depth study of the exterior form ideas, inspiration, and language which presents notion through design. Hadid's architecture tells the project's story and produces the kind of architecture that Le Corbusier (1928) in *Toward New Architecture* described as real architecture. Zaha

Hadid has made many contributions to architecture practice, theory, and discourse; Born in Iraq, this British architect became the first female winner of the Pritzker prize - comparable to the Nobel Prize - back in the year 2004 in addition to becoming the first female recipient of the RIBA Royal Gold Medal. She is often hailed as the most famous architect ever in contemporary architecture (Giovannini, 1996).

According to her website, Hadid won 140 international prizes including the Scottish Design Award and the American Institute of Architects (UK) Award. She has designed many projects distributed over 44 countries around the world with many of them under construction, such as the Pierres Vives building in France, the Master Plan of One-North in Singapore, and Abu Dhabi Performing Arts Centre in UAE. Some built projects designed by her are the Aquatics center in London which inaugurated in 2012, Maggie's Centre Fife in Scotland (2006), Guangzhou Opera House in China (2009), and Maxxi Art Museum in Italy (2009).

There are a few studies done in regard with Zaha Hadid in Architecture including Master a thesis on *Zaha Hadid form making strategies for design* by AmatalRaof Abdullah in 2013, qualitative study using descriptive, analytical, and exploratory methods which the study emphasizes her strategy of designing architectural form as well as the principles she uses. Besides *Drawn into Space: Zaha Hadid* by Lebbeus Woods in 2008 dealing with the relationship between Hadid's drawing and her architecture. Finally a book on *Zaha Hadid; the complete buildings* which presenting some details of Zaha Hadid's projects including her early projects. Since there is a lack of academic sources on this topic this research covers most of the architectural issues related to Hadid design of the form. The focus is on studying iconic forms of her works which are mostly known for the abnormality of creating the architectural form.

## **1.1 Problem Statement**

Many studies exist which take up the mantle of exploring the work of famous architects, such as: Le Corbusier: an Analysis of Form (1996), Organic Architecture and Frank Lloyd Wright (2006), Form follows function for Meis Van Der Rohe, Frank Lloyd Wright to 1910 (1958), and Precedents in Architecture (2005, 3rd Ed.) and others. However, there is a shortage of written journals, books and articles related to the systematic analysis on Zaha Hadid Architecture. The study of A. Abudullah 2013 is one of the rare studies deals with Zaha Hadids architecture in general. While interest in this particular issue area is significant, it is not reflected in the insufficient literature and level of academic activity. In this sense, the current study is done to give service to those who are interested in architectural design in general and Zaha Hadid design ideas and approaches in particular.

## **1.2 Aim and Objectives of the Study**

The aim of the research is to examine Zaha Hadid pushed boundaries, explore the reasons behind the iconicity of her buildings, radical concepts, and inspiration in order to encourage architects to be more curious and knowledgeable about it. It is believed that, this study is beneficial to architects and students with an interest in Hadid's work and interested in inspiring from her architecture. With this purpose in mind, this thesis studies design ideas mainly represented with fragmentation and abstraction of the form in her works and their inspiration and reveals how Zaha Hadid managed to produce such unique architecture that influences and inculcates the culture of this era through her projects.

Accordingly the main questions are:

- What are the outstanding aspects of Zaha Hadid's building iconicity?
- How could Zaha Hadid produce such an iconic architecture?
- How are Hadid's buildings influential in the field of Architecture?

### **1.3 Limitation of the Study**

Hadid is considered as the most imaginative architect among her colleagues based on the number of projects she has designed, the number of prizes & awards she got and the richness of various concepts and iconic buildings she conducts, Hadid herself is an icon. Besides Hadid is originated from the same cultural geography that the researcher have grown up. The study cover major architectural issues related to the formative design ideas in Zaha Hadid architecture. The focus is on studying the forms of her works in term of design techniques, form patterns and formative ideas. It examines the Hadid way of design as a deconstructivist pioneer in architecture and the technique of her designs to find the iconicity issues that generate such impressive forms. The study is not going to discuss the technological, economic, environmental or structural aspects, it only deals with the generation of the architectural form in Zaha Hadid's projects. In order to study those issues of architectural design, seven well-known, awarded, iconic buildings of Zaha Hadid are selected basing on specific selection criteria's which discussed in the analysis section 3.2 and the names of selected cases are mentioned.

### **1.4 Research Methodology**

To understand design ideas and approaches of Zaha Hadid, a qualitative research is conducted for achieving the objectives of this research. A wide literature survey of Zaha Hadid's professional life and her discourses done to understand the design



techniques and form patterns in her architecture to achieve this goal, *Zaha Hadid form making strategies for design* by AmatalRaof Abdullah in 2013 is an essential source to read and understand design approaches of Zaha Hadid, the categories that are developed by Abdullah on design pattern and techniques are utilized for further understanding of her design approaches and ideas. In this study her design ideas regarding form generation are analyzed and discussed by referring to the study of Clark and Pause, *Presidents in Architecture*, 2005 accordingly a set of analytical diagrams developed by basing on factual drawings of the selected cases. As an attempt to make a clear vision of her design approaches. Zaha Hadid's seven well-known buildings are chosen as case study by setting selection criterias. Under this scope each single case is analysed and documented. They are techniques of design, patterns of form and formative ideas.

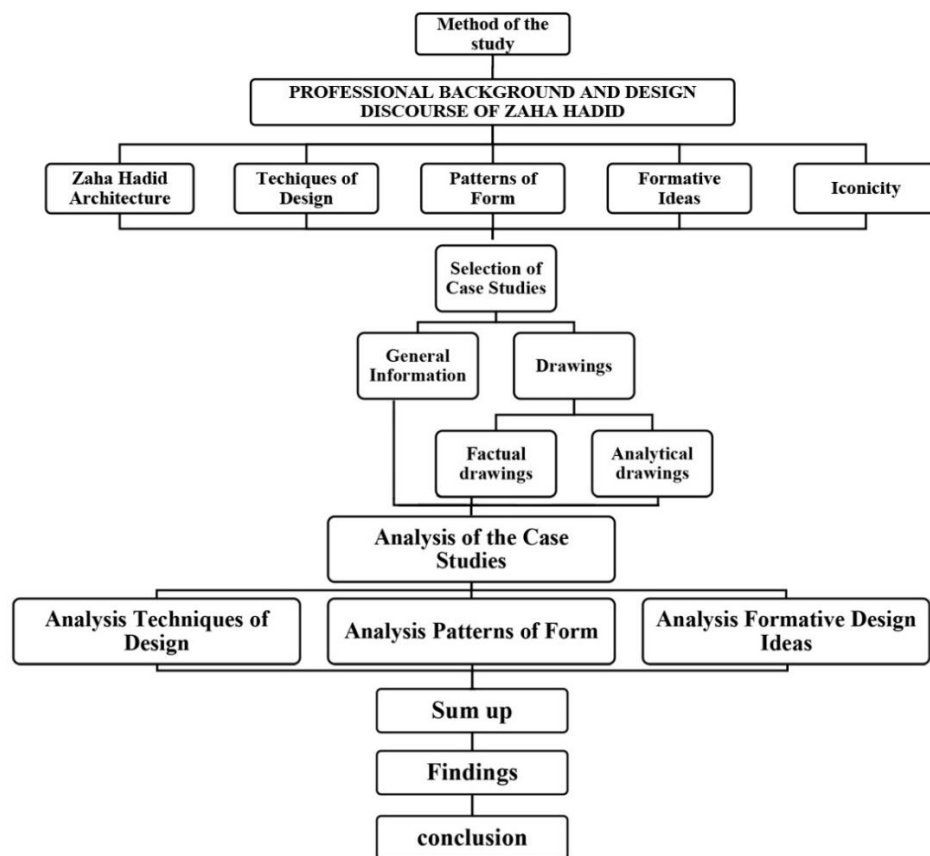

Figure 1: Structure of the study in this research

## **Chapter 2**

### **PROFESSIONAL BACKGROUND AND DESIGN**

#### **DISCOURSE OF ZAHA HADID**

Zaha Hadid's works are in the practice of architectural community continuously inspire re-reading and re-creating, her works are distinguishable. Design discourses distinguishes her own language and techniques from the others and puts an identity. In this chapter the several issues are discussed including Architecture of Zaha Hadid, technique of design in Zaha Hadid Architecture, patterns of form in Zaha Hadid Architecture, finally the formative design ideas in her architectural designs.

#### **2.1 The architecture of Zaha Hadid**

In this chapter, Zaha Hadid's development of professional life also her concerns and beliefs are discussed. In addition her contemporaries and critics are highlighted, also the iconicity issue in parallel with Zaha Hadid Architecture are discussed.

##### **2.1.1 Professional Development and Concerns of Zaha Hadid**

Zaha Mohammad Hadid is now one of the leading figures of the 21st century and she is taken after by energetic era for logical development and masterful creation. She was born in Iraq on October 31<sup>st</sup>, 1950, in one of Baghdad's point of reference Bauhaus-motivated houses (Forrest, 2008). Hadid experienced childhood in a rich Muslim family who accepts and shields popular government. In 1968, she considered arithmetic at the American College in Beirut for a long time where she wound up noticeably intrigued by geometry (Belogolovsky, 2008). In 1972, she relocated to London to enable her study design at the Compositional Affiliation where she got

recognition prize (Hadid, 2006). In 1977, she filled in as a band together with her educators Elia Zenghelis and Rem Koolhaas for three years at OMA (Office for Metropolitan Architecture).



Figure 2: Zaha Mohammad Hadid. Source: <https://www.dezeen.com>

Hadid had earned her architectural diploma in an environment full of differentiation and creation between the years 1972-1977. They offer them an inspiring atmosphere of deconstructing what is usual and producing everything new and extraordinary (Marjanović, 2010). This helps her to take her potential talent out and qualified her to subscript in MOMA for the first exhibition of deconstructivist architecture, which gave her international recognition for the strange design of the Peak in Hong Kong (Figure 3).

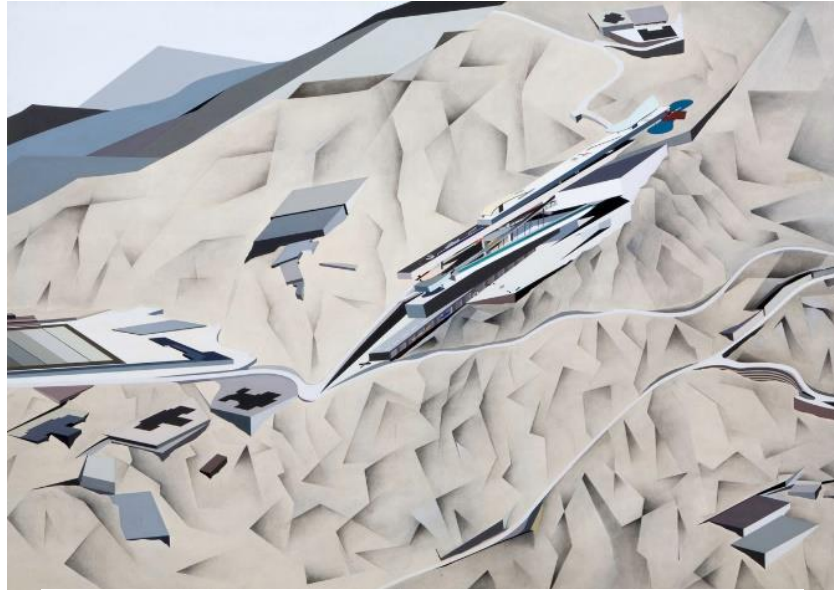

Figure 3: The Peak Leisure Club, Zaha Hadid, 1983.

In 1980, Hadid opened her own practice – Zaha Hadid Architects. After one year, she went to numerous urban areas in China where she found out about conventional design and craftsmanship particularly with respect to space, layering, and imaginative scene (Hadid, 2011). Returning to London, Hadid won the universal rivalry of the pinnacle extends in Hong Kong (1983) in which she got her first worldwide notoriety. She even turns out to be more celebrated through her membership of this venture in Exhibition hall of Current Workmanship, MOMA, in New York (1988). Her venture where portrayed as non-buildable, cloud, and hard to see "most MOMA guests found the new shapes, especially Hadid's puzzling. She displayed her thoughts in impressionistic, conceptual works of art, intended to get over the vibe of her spaces" (Designmuseum, 2007). In this venture, she connected what she had effectively realized in China went with a few methods of suprematist workmanship (Hadid, 2011). However this venture never fabricated and hence, she was depicted as a paper planner (Hadid, 2005). Her initially fabricated venture was the Vitra Fire Station in Weil-am-Rhein, Germany (1993) (figure 4).



Figure 4: Vitra Fire Station in Weil-am-Rhein, Germany, 1993.

Because of her notoriety of inventive thoughts, she was solicited by some from the prestigious colleges around the globe to show her creative ideas in engineering and workmanship, for example, Harvard College's School of Outline, Columbia College, AA in London, and College of Connected Expressions, Vienna. While she got many prizes, the most notable was the Pritzker Prize in 2004, for which she was the first female to receive this honor. Following this monumental occasion, Hadid engaged in many activities, and her works these days are disseminated everywhere throughout the world. Additionally, she has been picked as one of the first and most 100 persuasive identities on the planet by TIME Magazine and was named as the UK's craftsman of Peace by UNESCO (Designboom, 2010).

Through analyzing the works of Zaha Hadid, it could be recognized that her works are rightly placed under Deconstructivism because she has broken main principles in conceiving inherited architecture. In the following sub-chapter the study sheds light on Deconstructivism because Hadid is one of its pioneers.

### **2.1.2 Zaha Hadid and Deconstructivism**

After modernism and because of the fast development of science and technology, architects have the desire to give the real picture of their time and reflect it in their building (Hattenstone, 2010). The period of the mid of 1900s was highlighted by chaos and uncertainty, which appeared in works of some architects such as Coop Himmelblau, Peter Eisenman, Frank Gehry and others as discussed in *The Uncanny and the Architecture of Deconstruction* by Bart Van. However, the first appearance of deconstruction could be traced to 1917, the period of the First World War, when the Russian artist Vladimir Tatlin had drawn a new painting called constructivism that was really abstract and different (Mertins, 2006). According to Mertins, at that time, Russia had signed a protocol to end this war and announced the end of the Tsarist autocracy and beginning of the Soviet Union. Russia tried to recover from the huge damages befalling on it. With the strong desire of setting a new democracy and building the most advanced union in the world, it had launched a vast campaign: revolution in every sector such as science, economy; Art and architecture became aligned with the Russian Revolution's radical politics and served as instruments for the reorganization of life after the overthrow of the tsar. Constructivist architects devised new building types that would be commensurate with the forms of social organization desired in the new Communist state (Mertins, 2006:33).

This development in Russian architecture has influenced the vision of many architects around the world; one of them is Rem Koolhaas, the teacher of Zaha Hadid in Architecture Association in London. As one fan of the Russian constructivism, he taught it to students, encouraging them to produce like architecture by giving them the freedom in designing, expression and they were provided with the best teachers throughout the world.

Deconstructivism aims to destroy all the logicity of what postmodernism calls for, such as the imagery of historical buildings. It was described as the inhumanism architecture that is conceptually based on deconstruction, fragmentation, and extermination (Salama, 2007). Under the supervision of Philip Johnson and Mark Wigley, seven architects that were known for their deconstructivist style were invited to MOMA Exhibition (1988) in New York (Straeten, 1997). They have established a new architectural movement based on limitless and liberated form which its strategy totally reverses modernism's principles of design. The architects were classified into two groups, the first one were those who inspired their ideas from different resources such as Hadid from suprematism, Rem Koolhaas from constructivism and Frank O. Gehry from nature/organic. Generally, these architects conceive architecture as a creative image or sculpture. The second group were the Derridean architects who deconstruct philosophically in text then reflect it in their works like Peter Eisenman, Bernard Tschumi, and Daniel Libeskind (Straeten, 1997). The first group is more reasonable and realistic than the second one; the causes for which are explained later in this section.

Deconstructivism as an architectural style appeared in the late of 1970s characterized by excitement, mystery, and being full of life. It is assumed that the emergence and establishment of this style is the Architectural Association in London where the majority of the deconstructivist architects got their architectural degree (Hadid, 2006). Zaha Hadid is one of this movement pioneers. Her projects characterized by fragmentation and abstraction, however; the idea behind her architecture lies on the in-depth study of the exterior form ideas, inspiration, and language which presents notion through design. Hadid's architecture tells the project's story and produces the

architecture that Le Corbusier (1928) in *Toward New Architecture* described it as a real architecture.

Through analyzing the works of Zaha Hadid, it could be recognized that her works are rightly placed under Deconstructivism because she has broken main principles in conceiving inherited architecture, they are at the same time a prototype of good architecture that considers the needs of the human being as respect to the function and as a shelter that offers privacy and safety. As quoted by Gopnik (2011), Hadid stated that; “I don’t think that architecture is only about shelter, is only about a very simple enclosure. It should be able to excite you, to calm you, to make you think”. She also said; “Buildings should have an impact on the street life and they should draw people to them” (Zaha Hadid, 2010). She believes on Le Corbusier description of architecture “You employ stone, wood, and concrete, and with these materials, you build house and palaces. That is construction. Ingenuity is at work. But suddenly you touch my heart, you do me good. I am happy, and I say: this is beautiful. That is architecture; art enters in” (Ching, 1996: 375).

Zaha Hadid is roughly a new domain in both practice and theory of architecture. People started to be involved in such architecture and carry it out to the world. Since Hadid has much of the time announced that her initial undertakings are motivated from Suprematism (Dezeen, 2010; D'Apuzzo, 2011; Glancey, 2006), what follows is a discussion about its definition and foundation with a focus on the principles of Suprematism.

Suprematism is a Russian art movement founded by the artist Kazimir Malevich in 1915; the paintings here depend on an abstract geometrical method (Mertins, 2006). It



is associated with thoughts of spiritual purity and independence. In such ways of painting, it is somewhat difficult to specify what exactly is being represented because such paintings usually convey the designer's or the artist's inward state in an abstract way as opposed to an evident one (Kauw, 1998). In the Museum of Modern Art, Zaha Hadid's exhibition presented her works in abstract painting, however, Hadid could express her imagination and feeling from the radical and fluid spaces (Mertins, 2006).

As stated in *Generation of Abstract Geometric Art Based on Exact Aesthetics, Gestalt Theory*, Suprematism's roots can be found in the core of late modernist art movements, Expressionism. In the 1860s, Expressionism was the first movement that started to envision a new way of expression in painting – abstract art rather than classical examples that portray things as they are in reality (Kauw, 1998). As a consequence, new trends in art appeared to be more abstract in their expression like Impressionism, Cubism, Futurism, and Suprematism.

Starting as a futurist artist, Malevich converted to establish Suprematism, which he claims has no roots in Cubism and Futurism (Aiello, 2005). The majority of his work was informed by his search for that which is pure and uncontaminated (Bowl, 1976). Malevich's black square on a white canvas was the fire that ignited his Suprematist philosophy. He wrote about it "I have transformed myself in the zero of form, and through zero have reached creation, that is, suprematism, the new painterly realism on-objective Creation" (Bowl, 1976). He regarded the black square as a symbol of perfection and the base of all new forms, whatever they are. Malevich said in describing form in suprematism "forms of Suprematism have nothing in common with the technology of the earth's surface" (Crowther and Wünsche, 2012: 60).

A few Russian architects, like Vladimir Tatlin & Yakov Chernikhov, began applying Suprematism to their architectural projects in the early 1920s (Mertins, 2006). Architects such as these comprised the core of constructivism just as suprematism emerged as a new movement in Russian architecture. They incited a drastic overhaul of the country's architectural scene as it steered towards more iconic and abstraction (Belogolovsky, 2008). Figures 5 show some projects designed by Chernikhov expressing this style.

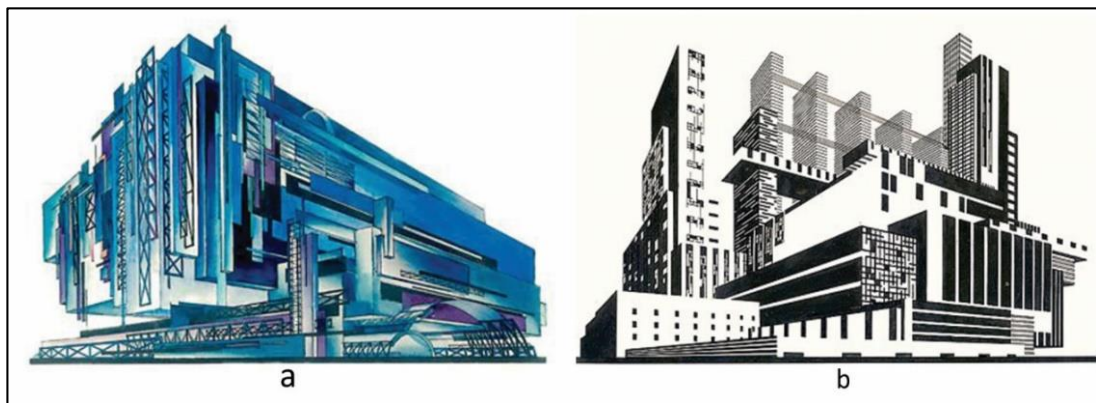

Figure 5: a) Suprematist project by Yakov Chernikhov featured by anti-gravity and using pure Geometrical forms, in early 1920. (Source: ethel-baraona.tumblr.com). b) Constructivist project by Yakov Chernikhov characterized by deriving project form from machine's shape in early 1920. (Source: bartletyear1architecture.blogspot.com)

Malevich, who started as a Fauvist artist then worked in the cubism manner, was searching for the purity of form (Ruddley, 1970). As stated in *Essays on Art, 1915-1933, vol. I and vol. II. Kazimir Severinovich Malevich*, Suprematist art was aimed at creating art that enticed the viewer with an immersive experience just as he tried to interpret it (Figure 6).

Hadid attributed her use of the painting as method of presenting her early designs to the better opportunity afforded by painting rather than drawing in conceiving space.

She also mentioned “the paintings really came because I thought the projections required a degree of distortion and defacement at the time, but eventually it affected the work itself” (Belogolovsky, 2008).



Figure 6: Abstract Painting Presented in 2D pure geometrical forms by Malevich. (Source @ lightinthebox.com)

Hadid is of the strong opinion that architecture has an effective role to play in regards to humans' moods, quality of life, and perception of the world. She posits that architectural pieces are about more than merely hosting the activities for which they were created but should also enhance thought and feelings of calm, as she famously said: “Buildings should keep you dry and feed the soul” (Hadid, 2003). Moreover, she believes that architecture should always leave a lasting impact and attract people to experience (Hattenstone, 2010). Hadid wants her work to both connect with and create a novel landscape to parallel modern cities and the lives of the people in them (Glancey, 2006).

Hadid's disdain for repetitiveness in the general views for the projects causes her to experiment with alternative techniques such as fragmentation and layering in her rejection of conventional architectural practices, which results in uniformity and a lack

of diversity. She described such architecture like mass production of the industrial period (Hattenstone, 2010). She considers her trend as a continuation of modernism's mission in regard to breaking the inherent rules merging that with the learned principles from Suprematism: avant-garde movement in art (Belogolovsky, 2008).

Producing engineering characterized by smoothness and many-sided quality was her desire and was the objective that she anticipated accomplishing in her works (Plan Exhibition hall, 2007). This aspiration has been accomplished effectively by emulating shapes in the rich source; nature and qualified her attempts to be agreeably as a finished piece of the general scene. Hadid considers design as an item that "takes after the innate rationale of cycles of advancement created by social and innovative improvements" (Didero, 2012). She alluded her prosperity to experiencing the obscure place as she stated: "It is not possible to achieve an advance without an element of uncertainty, without an enticing embarkation into the unknown" (Hadid, 2002).

Zaha Hadid has tried to conjoin a design educated by Deleuzoguattarian procedures of smoothing and collapsing to contemporary hypotheses of work administration and working environment association. In doing as such, they have contended, they are seeking after a "dynamic" and "emancipatory" extend. Their contention for this suggestion rests upon the claim that the "multifaceted nature" of their formal procedures agrees with that of the social reality into which these are anticipated, and that the hypothetical assets of their 'vanguard' engineering adequately compare with those utilized inside contemporary hierarchical models. Demonstrative of this position, Hadid commented in her Pritzker Prize acknowledgment discourse of 2004.

It is my belief that the complexities and diversity characteristic of modern life cannot be confined to the simplistic platonic forms allowed for by the classical canon, just as the contemporary style provides insufficient means of articulation. Current times present layered and more complex social programs than were characteristic of early modernity. It is for this reason that the enlargement of the compositional repertoire designers and urbanists alike use in dealing with the increased complexity require particular attention. This, including efforts to express and organize a variety of dynamic processes within a tectonic and spatial construct (Hadid, 2009).

Despite of being a leading figure of 21<sup>st</sup> century Zaha Hadid Architecture has been criticized widely by many architects and theorists in the following section, the critics and contemporaries of Zaha Hadid is highlighted.

### **2.1.3 Contemporaries and Criticism of Zaha Hadid**

Many architects and theorists have criticized Zaha for her abnormal architectural designs and confusing structures, her architecture was criticized as being aggressive, intractable and bitter. They are called over budget, expensive and not economic projects, Gigantic in scale and not considering the contextual features. The Guardian newspaper's renowned British architecture critic Rowan Moore profiled Zaha Hadid and her work so far. Unimpressed by Hadid's techniques, his profile is essentially a delineation of the plethora of challenges that would be faced by clients and building users alike in a building designed by Hadid. The article's moderate title – "Zaha Hadid: A Visionary Whose Ideas Don't Always Make Sense" – fails to accurately capture the message contained within. In failing to offer a distinction between Hadid's architectural style and the constituting genre, Moore appears unaware of the fact that his critique constitutes a critique of modern architecture as a whole (Moore, 2015).

Following his description of the numerous shortcomings he describes as characteristic of Hadid's designs (as well as others in her firm), Moore paints a picture of Hadid's years of isolation where she was not as sought out because she is an Iraqi, a woman, her personality, or even the outlandishness embodied in her work. Regardless, her fortune has turned and she now enjoys the luxury of innumerable opportunities. Moore wrote:

At some point in the last decade Hadid and her office could have used their new-found fame and status in one of two ways. They could have addressed their weak spot, which is the high degree of difficulty that it requires to realize their works, in such ways that they really might transform the everyday experiences of living in cities. Or they could have set about creating ever more elaborate and disconnected icons. Which, unfortunately, is what they chose to do (Moore, 2015).

As discussed previously, Deconstructivism aims to destroy the logicity of what postmodernism calls for, such as the imagery of historical buildings. It was described as inhuman architecture that is conceptually based on deconstruction, fragmentation, and extermination (Salama, 2007). This kind of architecture has been criticized by numerous architects who have made many complaints about it, especially those who are interested in reviving the traditional vernacular architecture. An example of such criticism comes from Salingaro and Masden who described it as "architecture of appearances" and said:

"Detached from the world of lived experience, architecture as image reveals itself as nothing more than a fashionable commodity. As such, it is

subject to the rules of constant change characteristic of the fashion marketplace. This type of architecture cannot respect the physiological needs of human beings. Looking around us verifies that these recent architectural practices have effectively erased the design and building traditions of the past, and with them the vital web of urban culture in society” (Salingaros and Masden, 2007:49).

In spite of an extensive campaign against such architecture, it has become the most supreme, popular, and attractive option for most people. Moreover, it becomes a measurable sign of the luxury and advancement for the countries acting as incubators for such projects. Deconstructivist projects have taken their place in the world and have a good reputation because of their extraordinary trend and inventiveness.

Writing in *The Spectator*, the architecture critic Stephen Bayley stated that Zaha Hadid “has added much to the formal language of global architecture, but not to its good sense”. For this reason, he is of the opinion that architecture would fair much better in her absence. In support of this claim, he provides evidence from a number of her more popular projects, such as the 2012 Olympics Aquatics Centre, London, and the 2022 World Cup Stadium, Qatar, both of which have been critiqued for their lavish costs as well as their futuristic, elaborate designs. According to Bayley “[s]he became the champion of an architecture that was more about personal ‘vision’ than public utility”.

Modern architecture has often been criticized for disregarding context and often resulting in expensive buildings that do little in the way of fulfilling their intended functions despite how visually captivating they are. Many consider Hadid to be the embodiment of this kind of architecture. Bayley observes that “Critics mumbled that

she had no sense of context or locality...preferring to crash land photogenic concepts whose function was not to serve her client's needs, but to advertise herself as a 'global architect'."

This position however, is hardly universal as her career continues to soar and Hadid, who has been said to be "the most famous female architect in the world", continues to receive numerous high-profile commissions. Bayley observes that while her designs may have revolted a number of people, others have been impressed by them; "Her reputation was boosted by a clique of fawning admirers who saw in her uncompromising angles and, later, zoomorphic blobs a fearless repudiation of stuffy tradition."

However, in 2012, when Hadid's design won the competition for the 2020 Tokyo Olympic stadium, the critics were extremely, and vocally, displeased. A company of Japanese architects launched a movement that eventually forced Japanese Prime Minister, Shinzo Abe, to cancel the project and start over with a new design. The Japanese opposition included Pritzker Prize winner Fumihiko Maki, who held a symposium in opposition of the project, and architect Arata Isozaki, who described that stadium as "a turtle waiting for Japan to sink so that it can swim away". Maki's symposium resulted in an 80,000 signature petition—almost equal to the number of proposed seats in the stadium—that demanded either a revision or cancellation of the project. Some opposed the stadium's mammoth 70-metre height in a 20-metre height limit low-rise district. The stadium was designed as a "monstrosity completely out of scale with the surrounding mixed-residential environs."



Michael Hanson of the guardian recently spoke on the topic. He noted that while such public ridicule of a starchitect's grandiose project is unusual, he did enjoy the Tokyo stadium being compared to "a hairdryer, a spacecraft, a footbath, a rusting tank, a stranded turtle and a child's potty". There is no doubt that Bayley would also agree as he opined that "global architects such as Hadid do not want to respect their client or his site, but to venerate themselves."

Creating architecture characterized by fluidity and complexity was her ambition and the goal that she is looking forward to achieving in her works. Hadid believes architecture to be a product that "follows the inherent logic of cycles of innovation generated by social and technological developments". Zaha Hadid has sought to conjoin an architecture informed by the Deleuzoguattarian processes of smoothing and folding to contemporary theories of labor management and workplace organization. Full of rebel, mysterious thoughts, a rejection of the norm, and a strong will to succeed, Zaha Mohammad Hadid is now considered as a new architectural 'school' in the 21st century followed by a generation eager for scientific innovation and artistic creation.

Many famous architects was inspired by Zaha Hadid's projects and designs, Patrik Schumacher as the most famous name after Hadid is considered as a complimentary architect of Zaha Hadid Architecture, besides many other names to be mentioned such as Charles Walker, Tariq Khayyat, Sara Klomps, Paola Cattarin, some of them still working in Zaha Hadid architects.

#### **2.1.4 Iconicity and Zaha Hadid Architecture**

The iconicity in Zaha Hadid Architecture can be denoted obviously in her projects as they are a masterpiece that establishes a benchmark to be emulated by others, a design

that sets a new trend regarding functions/features, quality, and style, a design whose popularity remains unmitigated by the passage of time, an innovative design, in regard to its manufacturing and technology, They are also designs that inspires other designers.

In an effort to offer some clarification on the concept of iconic buildings, Jencks (2006) suggests that “an iconic building is created to make a splash, to make money, and the normal criteria for valuation do not apply”. He goes further to argue that such a building needs to uniquely impress upon observers either through its peculiar physical characteristics or its placement. It is noteworthy that icons are not erected solely for the purpose of financial gain, they are also intended to serve as landmarks and thus attract attention. The majority of iconic buildings tend to enjoy a relatively equal level of popularity, usually facilitated by the media attention they garner, causing them to draw notice to the city.

A building needs to incorporate a number of ‘integrated features’ in order to be considered iconic. These ‘features’ refer to the building’s peculiar design, overwhelming representation, and particular message, common to all buildings in different forms and configurations. The characteristics of iconic buildings are peculiarly related to humanity and specific locations; these characteristics form the basis for this thesis. And so, for present purposes, we take iconic architecture to refer to a variety of ideas. According to Cleo Broda, iconic architecture may be defined as any revolutionary large-scale structure that resonates with the public. So, it is possible to infer that the building must be considerably imposing, stand out, and have been designed by a reputable architect. Architecture therefore, is a tool that helps to

represent buildings' appearance and the development of the areas in which they have been erected. (Yvonne, 2009).

A building's appearance might be accepted in society in the absence of the aforementioned specific integrated features. Norberg-Schulz stated that "As an intermediary object the work of architecture does not describe the world, rather it unifies some of its aspects in a new meaningful whole." (Schulz, 1968). The properties of iconic buildings, as posited by Cleo Broda, can be found in the majority of the world's most iconic structures, such as Dubai's Burj Al-Arab. Iconic buildings are important for the development of an image for the modern city (King, 2008).

Published as *Cattermoleda Architectural Excellence*, Jencks' 500 iconic buildings introduced architecture as a visual phenomenon, which represents the twenty-first century's level of engineering and human imagination (Cattermole, 2008). In the same vein, Koeing (2000), while providing an overview of the most iconic buildings, described Los Angeles, USA as an iconic city based on the peculiarity and iconicity of its buildings. According to Sklair (2008), iconic architecture comes in either one of two forms.

Iconic buildings of the first kind tend to be memorable in addition to holding some special meaning for the designing architect himself. Such representative buildings are relatively common in contemporary time. For examples to discuss, Wright without Fallingwater, Corbu without Rochamp, Mies without the Seagram Building are meaningless. In the second form, the buildings are seen as status symbols for the relevant architect(s) and location in addition to their elevated aesthetic value. Here, Sklair directs his attention to the questions of when, where and for whom these

buildings are iconic in arguing that whether or not the building is local or global/whether or not it serves the community at large or the architect is also important (L. Sklair, 2008).

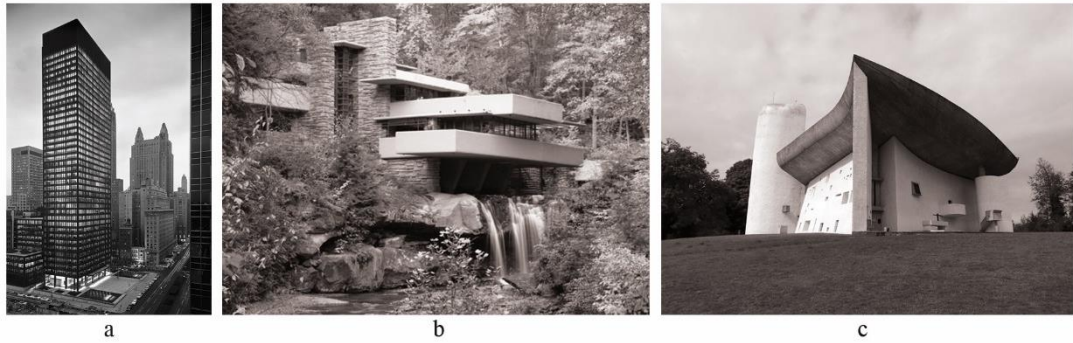

Figure 7: a) Seagram Building, Mies van der Rohe, 1958. b) Falling water, Frank Lloyd Wright, 1935. c) Notre Dame du Haut is a chapel in Ron champ, Le Corbusier, 1954. Source (L. Sklair, 2008).

Recognition of the fact that architecture is free from location and increases the value of its surrounding area necessitates an exploration of the relationship between identity, globalization, and architecture. King (2008) argues that in contemporary society, architecture is at a crossroads between identity and globalization. Consequently, architecture's role in the creation of a global identity remains important regardless of controversy. While this has little salience in the case of local architecture, similarities shared by structures erected in different city centers are increasingly making these cities appear similar. And so, erecting structures designed by internationally acclaimed architects serves to mitigate this trend towards quasi-uniformity and establish icons. As beacons of their cities, these iconic buildings are popularised by various media including cinema, television, internet, and press. Jencks (2007) argues that such buildings are gaining increased popularity and tend to have a power dimension to them.

Iconic designs are typically novel and set new benchmarks in the field. They are groundbreaking; as such, they serve as a template for emulation by other manufacturers and designers. Such designs tend to supersede the passage of time as they retain their iconicity even centuries later. Determining whether or not a design is iconic can be done on the basis of the following criteria (V. Ryan, 2010):

- A masterpiece that establishes a benchmark to be emulated by others.
- A design that sets a new trend regarding functions/features, quality, or style.
- A design whose popularity remains unmitigated by the passage of time.
- An innovative design, in regard to its manufacturing and technology.
- A design that inspires other designers.

To summarize, iconic designs can be separated into two categories based on their inspiration points – it can have a relationship with the culture of a nation or it can have an iconic design in a global era consisting different type of features like technology & material usage or sustainability. Iconic design principles are:

- A new international style, unique design, high standards of aesthetic distinction, technology, material usage, sustainability
- Culture, national identity, vernacular design, traditions of design.

As the sign of Iconicity, Hadid's buildings set benchmarks for other architects to follow; they are groundbreaking, innovative designs in terms of their technology and manufacturing; they set new trends and standards in terms of quality, function, and style; they transcend temporal limitations and have remained admired overtime; they place in history and contribute to the history and practice of Architecture. In the

following parts of the study, how Zaha Hadid's works are innovative, ground-breaking and setting a new design trends will be highlighted by considering the qualities in design techniques , patterns of form and formative ideas.

## **2.2 Techniques of Design in Zaha Hadid Architecture**

Known to push the boundaries of space, design, and conventional architecture, Hadid tends to create her own rules, which result from the combination of rationalism and her experience. As had been mentioned earlier, because she is a committed student of architecture, nature, art, and the elements of effective surroundings, Hadid has been known to explicate their aesthetic qualities and attractive characteristic, and apply them in her projects. This yearning helps Hadid to obtain some primary skills she diligently developed into her signature techniques. In general, Zaha Hadid used six different techniques of design which are defined by Amatal Raouf Abdullah (2013), the techniques are Abstraction and Fragmentation, Idea of ground and gravity, Landscaping the surroundings, Layering, Play of light and seamlessness and fluidity. Also some sub techniques which are: imitating the form of the project in the design of the interior space, use of distorted addition and subtraction technique accompanied with strong justified notion are used (Abdullah A. 2013).

### **2.2.1 Abstraction and Fragmentation**

Abstraction and Fragmentation are Hadid's first techniques in her creation of deconstructivist architecture. As stated by her "my discovery of abstract as a principle of research and discovery of space" (D'Apuzzo, 2011). Abstraction entails a deconstruction of the conventional illustration of a thing and transposing it into abstraction so as to depict it in geometric shapes and volumes, and alter its organization through aggregation or overlapping. Hadid describes applying the process of fragmentation as thus: "Break the block, make it porous" then it appears

“organizational patterns which imply a new geometry” (Meades, 2008). To make architecture abstract is to portion, tend, and dismantle it into parts which led to creating porous and new geometrical building characterized by multiple perspectives masses. The use of suprematism, as a principle of abstraction, instills architecture with elements of deconstruction, thus resulting in Hadid’s iconic architectural print. It is also to break free from applying architectural laws, which could lead to the production of uniform architecture, or as Hadid put it, industrial mass production (Hattenstone, 2010).

She learned the roots of abstraction from the Suprematism movement, which has been developed by her to establish the Hadid deconstructive style of architectural presentations. She considered abstraction “as a heuristic principle to research and invent a new kind of space” (Hadid, 2011; Greenway, 2011). She also refers the success of her early works to these two techniques (Designboom, 2007).

As one of the pioneers in Deconstructivist Architecture, Hadid applies fragmentation as the main principle used in almost all of her early projects. Learning abstraction from Kazimir Malevich, whose suprematist canvases used geometric and abstract forms, she considered fragmentation and abstraction as tools of discovering space, the principles of research, and a way to unbound invention (Michaud, 2011; Greenway, 2011). Hadid suggests that abstraction allows her to explore the manner in which lines intersect and her work has been influenced by a desire to replicate the manner in which a line is altered and distorted when you try to trail it in a building as it transverses both light and shadow (Michaud, 2011). One example of that is Italy’s Maxxi: National Museum of XXI Century Art in Rome. In effect Hadid applies different ways of abstraction and fragmentation in her various projects. They are mainly collision,

explosion, shattering, fragmentation, abstraction, distortion and deformation, folding, twisting, erosion, melting, throwing, which are summarized in (Table 1).

Table 1: Abstraction and fragmentation Techniques by Hadid. Source: Author by basing on Abdullah (2013)

<b>Collision</b>	<ul style="list-style-type: none"> <li>• It is known when a collision happens between two things, the damage and devastation will affect one or both causing thereby a deformation in the general appearance of them.</li> </ul>
<b>Explosion</b>	<ul style="list-style-type: none"> <li>• Naturally, when explosion happens, it starts from focal point to radially causing damages everywhere around.</li> </ul>
<b>Shattering</b>	<ul style="list-style-type: none"> <li>• Smashing thing usually resulted in breaking it down into scattered fractions.</li> </ul>
<b>Fragmentation</b>	<ul style="list-style-type: none"> <li>• The fragmentation notion of the peak project was a result of presenting the geology of the site in a suprematist manner which was in a mountain</li> </ul>
<b>Abstraction</b>	<ul style="list-style-type: none"> <li>• Hadid applies abstraction in her works by designing in a novel way has not yet been conceived or imagined.</li> </ul>
<b>Distortion and Deformation</b>	<ul style="list-style-type: none"> <li>• Such a technique could be done by drawing in a perspective way. Hadid in majority of her early projects used to conceive the building in a perspective of three points and deal with this distortion of diminutions in the real structure of the project.</li> </ul>
<b>Folding</b>	<ul style="list-style-type: none"> <li>• Form is an extension of the ground folded to form project's walls and ceiling</li> </ul>
<b>Twisting</b>	<ul style="list-style-type: none"> <li>• By twisting the forms in several direction to enhance the important parts of the buildings</li> </ul>
<b>Erosion</b>	<ul style="list-style-type: none"> <li>• By making designs porous giving the sense of continuation between inside and outside the building and defying gravity</li> </ul>
<b>Melting</b>	<ul style="list-style-type: none"> <li>• Is to regenerate the site and integrate it as much as possible with the surroundings</li> </ul>
<b>Throwing</b>	<ul style="list-style-type: none"> <li>• By throwing convention to the winds, nearly changed the way space is perceived</li> </ul>



### **2.2.2 Idea of Ground and Gravity**

Arguably the most famous architect who uses the method of defying the ground, issues regarding the ground are of the utmost importance in Hadid's projects. She experiments with the conventional static nature of the ground floor, floor suspension without supporting beams/pillars, and porousness to enable certain components function individually. Therefore, her works could impose themselves more assertively on the urban condition (Hadid, 1998). Regarding the idea of the ground, Hadid usually tries to defy gravity in her designs. The use of this technique was the reason of her being recognized as an architect who designs the unbuildable. Generally, in her works, she does not deal with right-angles; she instead uses tilted columns and fluid surfaces characterized by motion, power, and energy. Her justification for this practice was: "There are 360 degrees, so why to stick to one?" (Zaha Hadid, 2011).

According to Hadid, fixed concepts regarding the ground were to blame for the trend amongst modernist architects towards the creation of similar architecture (Hattenstone, 2003). She on the other hand, acquired the practice of defying gravity from Suprematism. Kazimir wrote, "We can only perceive space when we break free from the earth, when the point of support disappears" (Bedell, 2003).

This understanding has immensely influenced Hadid's conception of architecture as defying the law of gravity and breaking free from the ground is characteristic of most of her works. She studied the active liberation and usage of the ground from Mies van der Rohe, particularly his Barcelona Pavilion project where he raised the ceiling using finite sections of separated walls (Hadid, 1998). Due to her commitment to "the continuation of the unfinished project of modernism," she is consistently generating many ways to represent this technique. The following are the applicable ways of

breaking free from the ground through Hadid's designs. Also, it includes the ways used to liberate the ground and let some parts of the building operate individually: Mass Cantilever, Ground Extension, Carve the ground, Inclined Columns, Multi-Grid, Deep Emanation for Some Masses, Cantilevering, Inclined Mass from the Inside Out, Making the building porous, Mass Manipulation, Liberate the ground (Figure 8).



Figure 8: Mass cantilevering and porosity with the idea of ground and gravity

### 2.2.3 Landscaping the Surroundings

Despite the variety of materials and form in Hadid's projects, the compatibility of her structures with their immediate environment has often been called into question. A concern, which Hadid neutralizes with her intense research into the environment and site of any prospective project. Similarly, the chosen landscaping for the project is intended to complement the urban image of the surrounding area rather than function in isolation. Hadid is known for her constant attempts at harmonizing the project with the relevant environmental context through the consideration of all possible factors, including the landscape and topography, and adapting them to seamlessly blend with the site landscape (Colegio, 2012). From the onset of the design process, she attempts to link elements of the project to the particular context and the context to the project so as to ensure coordination between the two.

Hadid developed this method based on Chinese landscaping and architecture and applied it to her architecture. In describing such experience, she said that she admired “the way Chinese gardens manipulate and integrate intensive elements of nature; and the way the traditional architecture is embedded within the great theater of natural landscapes” (Platt, 2012). Using this method affects both the general form and orientation of the building.

Landscaping techniques is done through different application which are: elevating the ground floor or part of it, vanishing, topographing the project, using one color of the building, the pavement of the project, line formation, transparency in the ground floor, landscaping the roof, gardening interior spaces, wall extension, forming the project according to current urban grid, designing the building in parallel with land’s shape, melting the building to meet the ground (figure 9, 10).



Figure 10: forming the project in the current urban grid in Maxxi: National Museum, Rome, Italy, 2009. (Source: <http://www.zaha-hadid.com>)



Figure 9: Landscaping the roof in Dongdaemun Design Plaza, South Korea, 2013. Source (Source: <https://www.flickr.com>)

#### 2.2.4 Layering

This method allows Hadid to generate fascinating spaces and voids in line with her architectural space expectations. With the aim of creating complex, fluid spaces, Hadid

tries to achieve this by applying layering technique (Belogol ovsky, 2008). This technique allows for the creation of amazing fluid interior spaces by manipulating the interior wall borders especially the main foyer of the building. A large fluid foyer is understood to be Hadid's most striking impression in most of her larger projects and is taken to be the primary consideration in socializing the project (Futagawa, 2010). A good example of this way is Museum for the Royal Collection in Madrid which its design was "inspired by the morphology of erosion" (Hadid, 2009). It is the first project designed by Hadid with regard to apply layering technique to generate fluid space. Figure 11 shows the bold manipulation through the ground of building floors resulted in generating amazing interior fluid foyer.

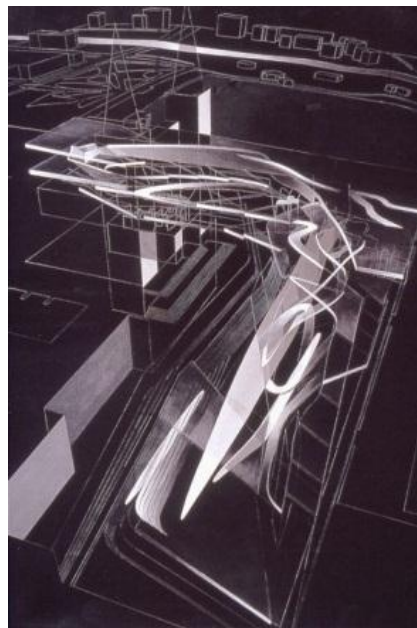

Figure 11: Generating fluid space through layering, Museum for the Royal Collection Madrid, Spain (1999). (Source: Abdullah, 2013)

In painting, layering involves the application of more than one coat of paint to provide depth. However, for present purposes, the term is understood to mean dealing with building floors are separate levels, or layers; to pay minimal attention to the lower floor

grid. It is like what Zaha stated in her article in the China Daily USA Newspaper “I believe the complexities and dynamism of contemporary life cannot be cast into the simple orthogonal grids and blocks of the 20th Century architecture of Henry Ford's era” (Hadid, 2011). Layering therefore, involves altering the positions of the floors, in regards to superposition, with a result similar to the vibrant firm of the Peak project in mind (Figure 12).

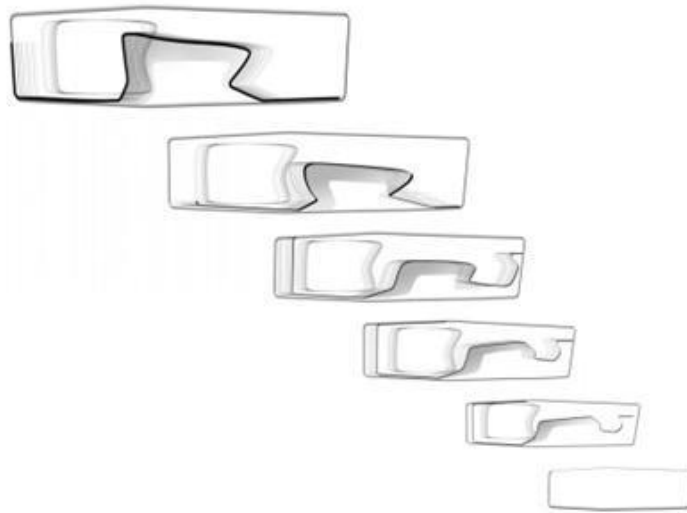

Figure 12: Space creation through layering manipulation in Darat King Abdullah Art Cultural Center in Amman, Jordan (2008). (Source: Abdullah, 2013)

### **2.2.5 Play of Light**

Play of masses, within the element of sunshine, is one procedure frequently utilized by Hadid whereby the shadow component adds movement and vivacity to the height. Play of masses can be accomplished by utilizing clasping, sinuosity, expulsion, fracture, deliberation, and making the building permeable. She remarked that "On the off chance that you consider changes in the play of light on a working before it was fabricated, you can differ the shading and feel of cement by sunshine alone" (Glancey, 2006).

Hadid enlivened this strategy from her contemplation of nature; she knows the reason why individuals are drawn to mountains; it is the result of the straightforward wandering in the mountains and the light variable which cooperate to depict a delightful view (Hattenstone, 2003). Covering and intertwining, Gathering, Juxtaposition and Fracture are the primary play of light utilized methods by Hadid in her ventures (Figure 13).

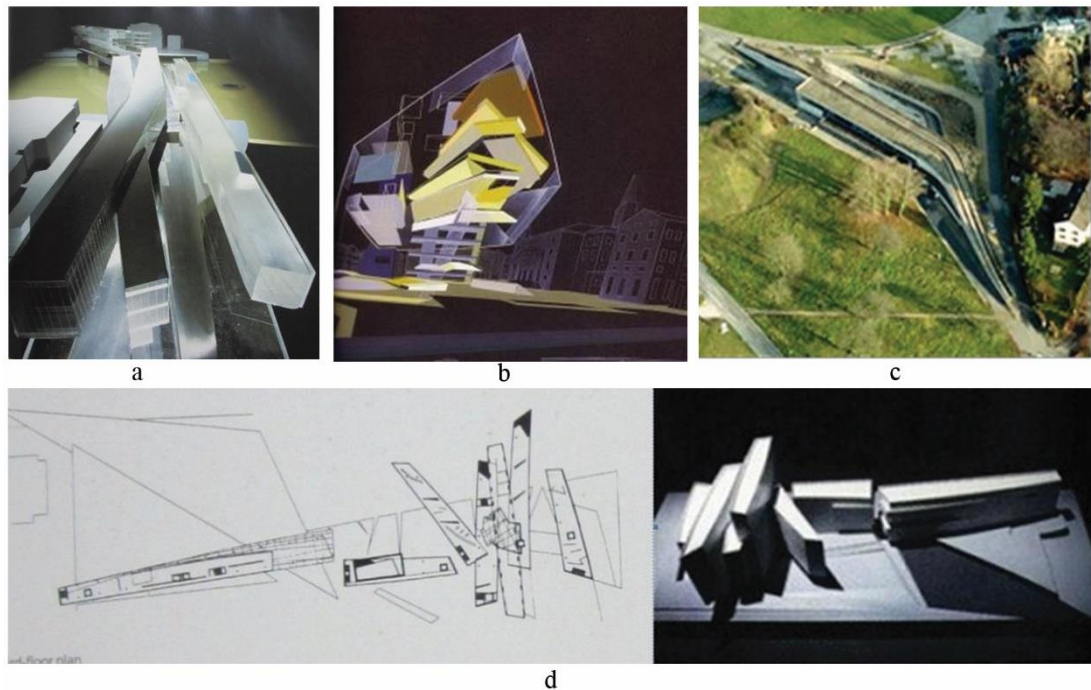

Figure 13: a) Overlapping & Interweaving. b) Accumulation. c) Juxtaposition. d) Fragmentation. (Source: Abdullah, 2013)

### 2.2.6 Seamlessness and Fluidity

The final technique entails the use of seamlessness throughout the project. In addition to fluidity, they are a prevalent characteristic shared by the majority of Hadid's work, particularly the most recent ones, where they are easily recognized. She got inspiration for this technique from the seamless pattern of the Sumerian village's landscape in Iraq, in which the sand, reeds, and water, combine to create a spectacular view (Glancey, 2006). Concrete is the best material for realizing the desired seamless



curvature and Hadid has been known to avoid L-shaped 90-degree corners while curving the surfaces to give the appearance of a continuously fluid space and sometimes even inclining The surface inward or outward; this depends however, on the architect’s aesthetic sense. The technique of curving surfaces is learned from “the intricacy and beauty of natural forms” (Pulse, 2011). Moreover, it offers more convertible and visible surfaces through which natural light can enter the building. The use of fluid spaces in her buildings makes those inside them unconsciously want to move around (self-movement), thus negating the need for signage or even an introductory guide (Abdullah, A. 2013) (Figure 14).

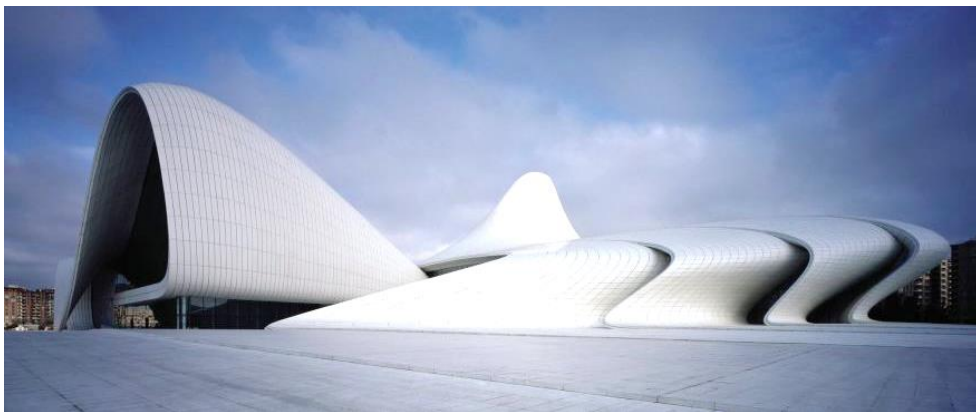

Figure 14: seamlessness of the surface in Heydar Aliyev Cultural center, Azerbaijan 2007 – 2012. Source: <http://www.zaha-hadid.com>

### **2.3 Patterns of Form in Zaha Hadid Architecture**

Going through Zaha Mohammad Hadid’s architectural works, one could see a large variety of forms and notions to the degree that some doubt the possibility of classifying them within specific categories. Generally, Hadid often works within the framework of five patterns in regard of projects’ form notion and the prevailing features of projects’ exterior configuration. Chronologically arranged, Hadid’s architectural form patterns are suprematist, topographic, fluid, organic, and parametric form. (Abdullah,

A. 2013) This part demonstrates the features of these prevailing patterns which arranged chronologically according to their appearance.

### **2.3.1 Suprematist Forms**

Her deconstructivist style developed from Suprematism; however, it is injected with ideas of fragmentation and deconstruction. Suprematism style also includes the very few early projects, the forms of which have some constructivist features. Constructivism is architectural movement originally inspired from Suprematism (Cooke, 1995).

Suprematism has some principles that could be recognized and identified through painting. One of these principles is utilizing analogous forms to offer harmony feature through painting. This feature is found in many of Hadid's early projects; however, she used to draw deformed rectangles; a perspective of three points such as Zollh of 3 Media Park in Germany (1989-93).

Something which is also perceptible in suprematist painting is the existence of supremacy for some shapes, with the purpose of attracting the attention of spectators to the artist's intention. Examples of such patterns are Malevich's Tektonic, the London and Irish Prime Minister's Residence, Ireland and almost of her works from 1976 until the mid of the 1990s. Another important feature in Suprematism is the notion of anti-gravity; flight. Therefore, projects whose main form notions are based on defying gravity, abstraction, and fragmentation which are the major design strategies of Hadid, are categorized under the Suprematist pattern (Figure 15).



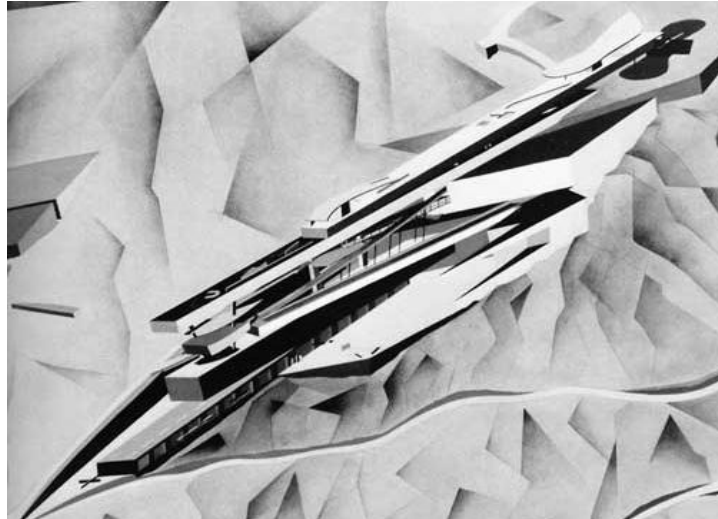

Figure 15: The supratist form of The Peak in Hong Kong (1982-83). Source: <http://www.zaha-hadid.com>

### 2.3.2 Topographic Forms

Topography which is a broad term used to describe changes in the earth's surface, had been the issue of Hadid's design. She stated that the ideas for this pattern always come from the same source (NewYooxer, 2010). It is characterized by drawing inspiration from the features of the Earth's surface shapes. It is a translation of land contours with consideration of site inclinations and their directions. An architect can derive many ideas existing in the natural diversity of the Earth's topographic forms, for instance, ridges, dunes, floodplains, moraines, penneplains, cliffs, and plateaus. She thoughts that God has innovatively created this diversity in nature for human beings to enjoy, contemplate, and draw inspiration from it.

There are numbers of important projects produced by Hadid whose form notions were inspired by topographic forms. The UK's Glasgow Riverside Museum of Transport serves as the perfect illustration. Inspiration for the museum's form notion came from the movement of desert sand dunes in conjunction with a slight detour inspired by its exclusivity as a metaphoric representation of the transmission link between Glasgow

and Clyde. Other examples are Landesgartenschau 1999, Germany and the E.ON Energy Research Center, the notions for which are inspired from the existing contours of the site with the intention of creating a harmony with the surrounding landscape (Figure 16).



Figure 16: The topographic form of Landesgartenschau 1999 in Weil am, Germany (1996-99) Source: <http://www.zaha-hadid.com>

### 2.3.3 Fluid Form

It is also called Kinetic Architecture or Water Architecture because of the symbolic similarity in the dynamic qualities. Smoothness, outflow, shapelessness, amorphousness and continuous seamlessness are some features of this pattern. It is also considered as multipurpose architecture (Methanoia, 2010). It can be employed as desired because its interior design is changeable. Although the fluid form is a permanent feature of most of Hadid's recent works and even includes other patterns such as organic and parametric designs, fluid form is categorized based on the form concept generated by Hadid's fluid sketches. She said: "My architecture takes the fluid dynamism of the sketching hand" (NewYooxer, 2010).

The fluid pattern is neither based on simulating organic things nor generating form by the feature of malleability in the parametric design system. Fluid architecture is

relatively common in the majority of Hadid's work, particularly in terms of fluid space. Hadid mentioned that, "Fluid form is a part of my architectural prints today, and space. The connection is in deconstruction and fragmentation" (D'Apuzzo, 2011).

She notably started working with this prototype in the mid-1980s, especially as it relates to furniture and interior design (such as 24 Cathcart Road in London). She has repeatedly touted her goal of fashioning a fluid space reflecting the speed of technological advancement in all of life's sectors "From my first days at the AA, I explored the concepts of fragmentation, abstraction, and explosion. . . , but my ambition was always to create fluid space" (Hadid, 2011; Greenway, 2011).

Hadid was inspired for this form by the fluid and kinetic lines of Arabic calligraphy which combine all the features mentioned under this pattern; Doris Bitter (2006) has studied this in *Inside Arabic Calligraphy from Alef to Zaha: an Artist's View*. One of Hadid's strengths is her well-curved lines, which are characterized by fading. Rem Koolhaas attributed her mastery in producing fluid lines to her Arabic descent as they are renowned for creating nice calligraphy (Hadid, 2006).

Hadid's fluid designs are characterized by smooth, seamless, and watery external surfaces, which are convenient for sight. She also uses fading techniques in this pattern, thus earning the projects a nice withdrawal for a scene from earth to sky. Fluid architecture also has the capacity to provide a clearer view of the immediate neighborhood and also permits more light than in cubic designs (Figure 17).

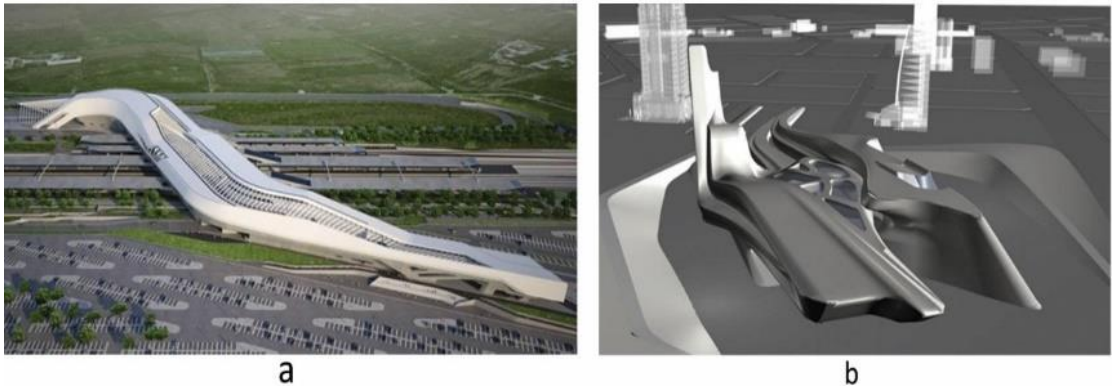

Figure 17: a) The fluid form of High-Speed Train Station Napoli Afragola in Naples, Italy (2004-14) Source: *The complete Zaha Hadid*. b) The fluid form of Guggenheim Museum Taichung in Taichung, Taiwan. (2003) Source: <http://www.zaha-hadid.com>

### 2.3.4 Organic Form

Organic architecture represents a living tradition. This controversial architectural form has always been hard to define. It was never really a style, but rather an approach. Organic architecture is rooted in life itself, nature, and all of its forms. Pearson states that the vernacular architecture of the aboriginal times was inherently organic as it was rooted in natural structures and forms, and was built using local materials (Pearson, 2001). Through history, there have been many styles, theories, and ideas based on the nature of the organic form and its principles. So, if we understand organic architecture as architecture inspired by nature, we can with caution say that it existed all through history in different emerging shapes. Louis Sullivan opined that buildings ought to “naturally follow suit in that their forms follow their functions, regardless that buildings are not in themselves organic things” (Cruz 2012, p. 28). Buildings are not born, do not grow or reproduce – they are made. Wright was one of the first to use the term ‘organic architecture’. In his earlier works, and nature as inseparable. This reminds us of on-going contemporary discourses regarding green or ecological architecture. The concept of organic architecture posited by Frank Lloyd Wright evolved from a group of architectural principles regarding the way of living.

‘Organic pattern’ is the term used for projects in which the form notion is rooted in simulating any creature or thing in nature. Some forms of Hadid’s work are inspired by phenomena in nature, such as animals and plants; sometimes it they try to emulate tiny details down to the level of cells. Recently, she has shown an interest in biological morphology (such as in the Abu Dhabi Performing Arts Centre in UAE). Most organic forms have asymmetrically curved surfaces, which motivated her decision to avoid corners and orthogonal walls in her work.

As known, everything in nature was created perfectly to adjust to its environment; Hadid’s way of designing organic forms is drawn from this observation. She always takes inspiration for the project form from the site and then she tries hard to adapt it to the context of the vital relationships “trying to draw out features from the context so that in the end there is a sense of “embeddedness,” and “fitness” into the context” (Belogolovsky, 2008). When Hadid decides to be inspired for her form notion by nature, she works on the principle of embeddedness, which involves using the latest technological solutions in order to meet all the requirements of successful architecture (Figure 18).

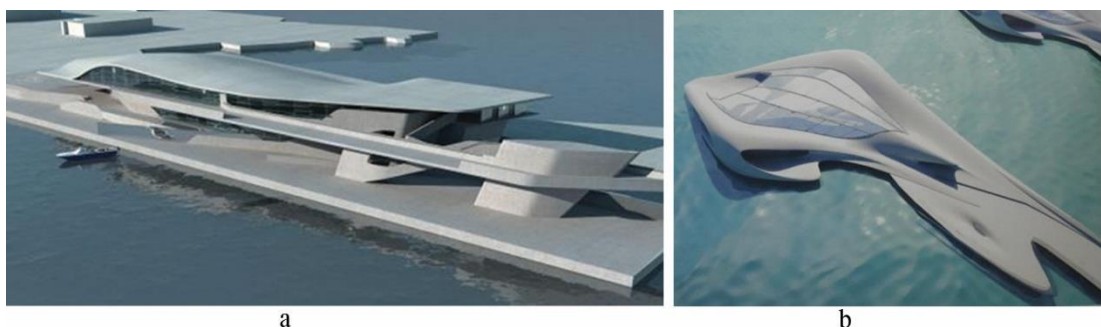

Figure 18: a) The organic form of Maldives Luxury Resort, Munandhua, and Island, Maldives, 2007. Source: *The complete Zaha Hadid*. B) The organic form of Golf and spa resort, Dubrovnik, Croatia, 2009. Source: <http://www.zaha-hadid.com>

### 2.3.5 Parametric Form

Zaha Hadid's Architects are interested in the techniques of digital animation as they encourage them to get involved and intensely deal with advanced parametric design systems. Their effective roles extend to include becoming one of the most advanced groups in developing such systems to meet their expectations and optimum goals. The parametric form is a relatively novel style in urban design and architecture. As stated in *Parametricism – A New Global Style for Architecture and Urban Design*, the early emergence of Parametricism could be traced back to the mid-1990s in digital animation techniques. This style has been advocated by Zaha Hadid's architects, particularly Patrick Schumacher, who is a lecturer at the Architectural Association in London, the main activist in establishing such trends, and Zaha's partner architect in many of her designs, especially the recent ones (Schumacher, 2009).

Schumacher (2008) opined that as a mature style, Parametricism is poised to become the leading architectural style of the century, second only to modernism. He went further to suggest that Deconstructivism, minimalism, and postmodernism were nothing more than periods of transition that aimed to fill the gap left by modernism (Schumacher, 2008; Futagawa, 2010).

This architectural style is based on innovative design research programs which develop gradually and parallel with the advanced progress occurring in the computational sector. These programs: MEL-Script, parametric modeling, and Rhino Script give variable and different innovative forms that could be enhanced by the aesthetical sense of the architect or designer (Leach, 2009). Forms generated by these programs are the result of morphing and dynamic change, which are reminiscent of those used in science fiction films. These programs have the ability to ingeniously connect the design of the

interior spaces with the exterior form and even within a large domain, such as the form of landscape and urban planning to portray them as one system. A good example of that is the Kartal-Pendik master plan in Istanbul, Turkey, 2006 (Figure 19).

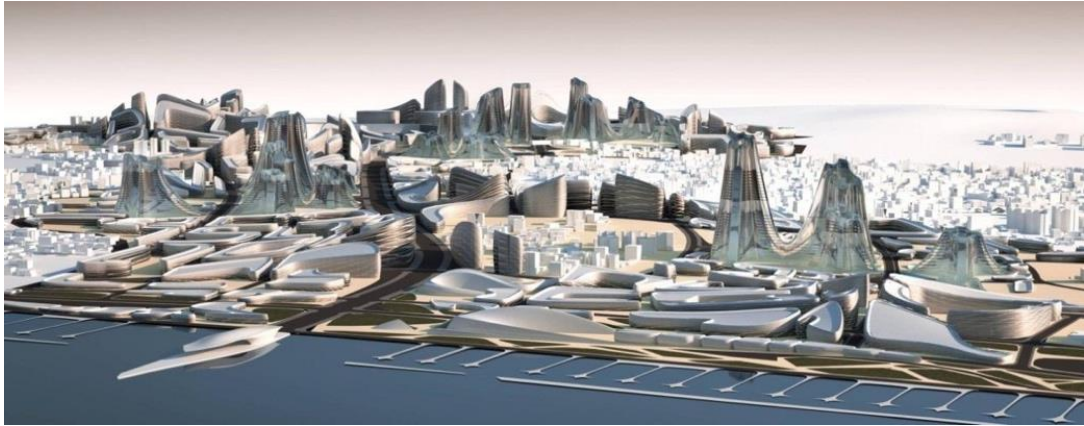

Figure 19: The parametric design of Kartal-Pendik master plan in Istanbul, Turkey  
Source: [www.zaha-hadid.com](http://www.zaha-hadid.com)

The form in this program could be manipulated to get various numbers of new forms because of the malleability feature of the form afforded by the program until the desired result is attained (Futagawa, 2010). The form-finding process is a process by which exterior forms fit interior structures (Yuan and Yi, 2012). As this system enhances the number of new imaginary forms, it prevents the designer to work within specific areas; Schumacher called these areas taboos. Taboos are paths that might trap the architect and make him revert to old styles. These taboos work with pure geometric forms, using simple repetition, and finally offer juxtaposition of unrelated forms (Schumacher, 2008).

The parametric design system is designed based on a set of quantitative data connected with qualitative data. Therefore, any changes in the quantitative data will translate into a modification in the form and drawing. Moreover, this system offers an optimal feature that is rare in other systems; it is the use of scientific experiments, which



provide the system with strong, carefully studied solutions and facilitate many things for the designer.

To sum up, Hadid’s architectural forms and techniques are characterized by a defiance of the rules, pushing limitations, and building what was hitherto unbuildable. As a result, her buildings nowadays are considered one of the most attractive architectural styles in the world, such as the Heydar Aliyev Culture Centre in Azerbaijan and Guangzhou Opera House and Galaxy SoHo in China. Her architecture attracts people and media, and is considered to be an indicator of the strength of the country’s economy incubated such projects such as China. From this point of view this research clarifies Hadid’s architecture and the underlying reasons for its iconicity. Finally the patterns of form in Zaha Hadid Architecture are five main patterns which are Suprematist Pattern, Topography Pattern, Organic Pattern, Fluid Pattern and parametric pattern. Each of them have specific characteristics that can be pointed in the buildings obviously as illustrated in (figure 20).

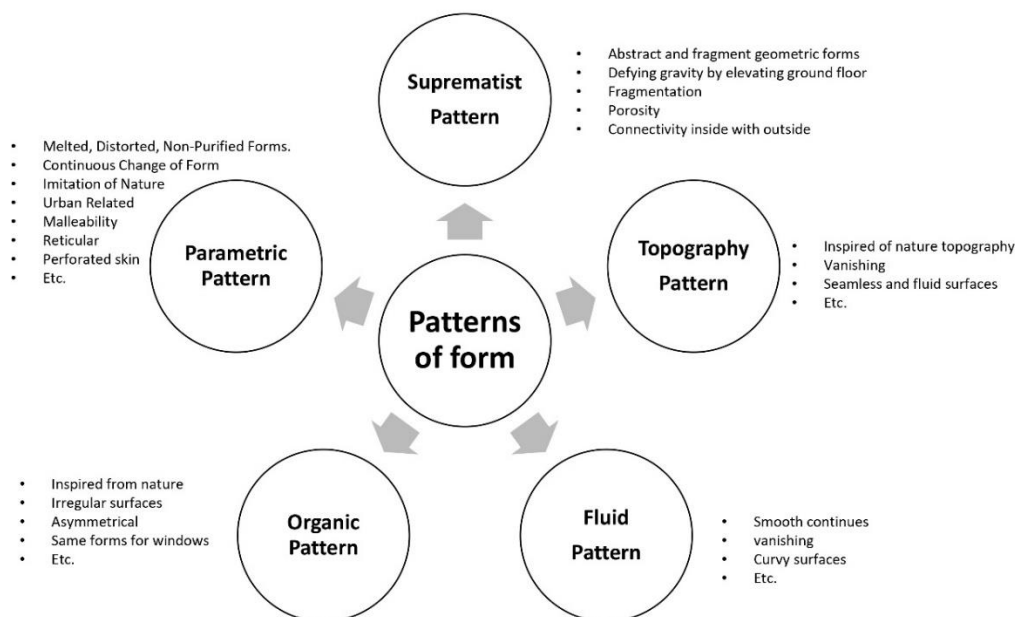

Figure 20: Illustration of Form patterns in Zaha Hadid Architecture. Source: Author based on (Abdullah A. 2013)



## 2.4 Formative design ideas in Zaha Hadid Architecture

Zaha Hadid has special concerns on the development of certain formal languages in her designs. This is why it's important to conceive those formal characteristics in order to have a comprehensive understanding of Zaha Hadid Architecture so as to formulate her formative design ideas. Some parameters are borrowed from the study of Clark and Pause, 2005 and are to be interpreted in the following lines.

**Massing** is arguably the most common 3D building configuration and enjoys perceptual supremacy. Going beyond building elevation and silhouette, it refers to the building's total perceptual image. Although it occasionally parallels, approximates, or even embodies the building elevation, understanding it solely in this manner offers a severely limited understanding. To illustrate, just as the fenestration may not affect perceptions of the building's volume in regards to its elevation, the building's silhouette might also be overly general and fail to represent the distinctiveness of its form (Clark & Pause, 2005). Massing, seen as a consequence of designing, can result from decisions made about issues other than the three-dimensional configuration, viewed as a design idea, Massing may be considered relative to concepts of context, collections, and patterns of units, single and multiple masses, and primary and secondary elements. It may potentially be used in architecture to define and pronounce outside spaces, delineate entrances, lay emphasis, accommodate sites, and express articulation (Figure 21). As an architect, and in an act of deconstruction, Zaha Hadid altered her planes, massing, spatial envelopes, and other expectations in a playful rebellion.

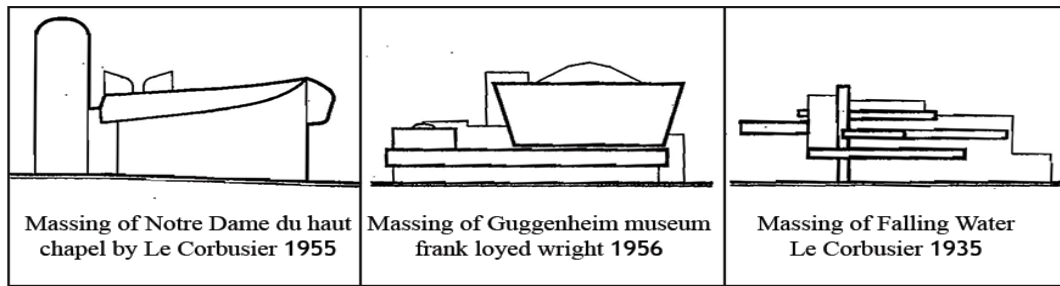

Figure 21: Massing in three famous buildings (Clark & Pause, 2005)

**Balance and symmetry** have been in use since the beginning of architecture. As a fundamental issue of composition, formal and spatial components are used to attain balance – a condition of either conceptual or perceptual equilibrium – in architecture. Symmetry occurs when the first half of the form or façade is the same as the second. Duality is similar to symmetry; while duality is the term used to describe balance happening between two equal separated forms, symmetry is used to describe the perfect similarity between two halves of one form (Zunde and Bougdah, 2006). Asymmetry is another condition in which the balance and equilibrium could be evaluated only by sight. Figure 22 is a depiction for the three cases of balance; the first one is a typical symmetry in architecture which the right side of the form is exactly the same in the left while the second and third drawings are consecutively the duality and asymmetry balance cases (Clark & Pause, 2005).

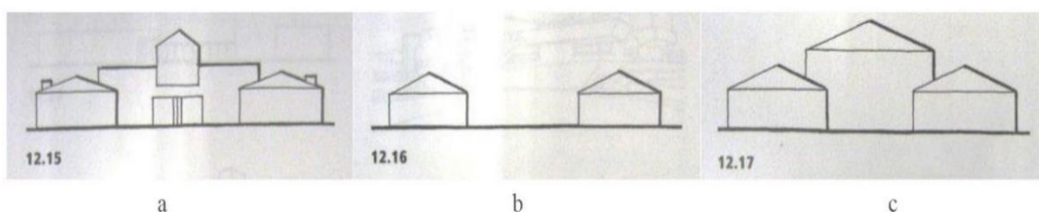

Figure 22: The three conditions of conceiving balance; (a) symmetry, (b) duality, and (c) Asymmetry. Source: *Integrated Strategies in Architecture, 2006*

**Relationship between Plan and Section / Elevation** could be helpful if an architect uses it as an identifiable correlation between the horizontal and vertical configurations. Therefore, whatever a kind of configuration is used in one should affect the other regardless of which is designed first. Clark & Pause have addressed five kinds of interactive, formative relationships, which are: firstly, an equal relationship between them; whatever configurative line or form is used in the plan, it also used typically in the section or elevation and vice versa. Secondly, one to the one-half relationship is the configuration which is embedded 100 percent in one and 50 percent in the other. Thirdly, an analogous relationship occurs when the configurative line is similarly found in both of them. Fourthly, a proportional relationship is the one existing when one configurative form is embedded in the other with some difference in the formal proportions. Finally, there is the inverse occurrence of relationships that happens when the configuration of one is connected to some opposite condition in the other (Clark and Pause) (Figure 23).

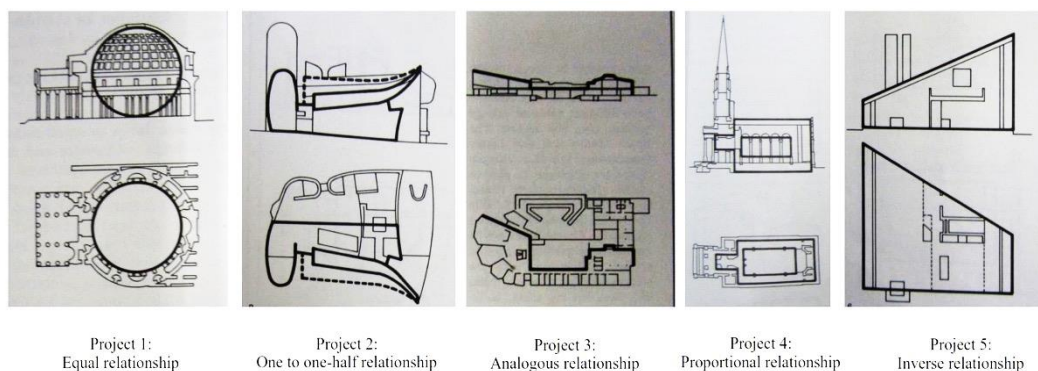

Figure 23: The five types of formal relationship between plan and section or elevation. Sources: Clark & Pause, 2005

**Repetitive to unique:** Elevation, plan, and section are conventional in simulations of buildings' vertical and horizontal configurations. Similar to other design ideas considered in this study, other considerations may affect the relationship between the

plan configuration and vertical information. The building plan is considered to determine its form as it organizes building activities and may also serve to determine the outcomes of a number of decisions, such as the size of passages. Regardless, the building's section and elevation are taken to relate more closely to perception as they share similarities with a frontal encounter with the building. The use of either plan or section however, assumes a volumetric understanding that a line in either has a third dimension. The interdependence and reciprocity between both drives design decision-making and doubles as a design strategy. Decisions regarding the elevation, plan, or section, influence other design considerations such as similarity, equality, proportion, and difference. It is likely for the plan to relate to the section or elevation on a number of scales: a room, a part, or the whole building (Clark & Pause, 2005).

**Geometry** embodies the tenets of both plane and solid geometry in determining the built form. In this context, grids are understood to result from repeating basic geometries by combination, multiplication, combination, and manipulation. It has been employed as a tool of design from the onset of architecture itself and is probably the single characteristic common to all buildings. It can be used in a wide variety of formal and spatial levels, either in the form of basic geometric shapes, different language forms, complex forms generated via geometric manipulation, or proportion systems. The realm of geometry as an architectural form generator is a relative one of measurement and quantification (Clark & Pause, 2005).

In the buildings of Zaha Hadid, mostly complex geometries are used. So, it's difficult to analyze her buildings as simple geometric forms, as an attempt for ease the analysis procedure leads to the introduction of a complex geometric surface. In geometry, a quadric surface with no center of symmetry and only one symmetrical axis I known as

a paraboloid. The word "paraboloid" is a derivative of parabola - a conic section with the same property of symmetry. The five sections, which can be cut alternatively through a (double) cone object are, in descending order: a hyperbola, a parabola, an ellipse (including a circle), a (double) line, and a point. Each of these can be generated simply by altering the degree of inclination of the section plane. If one extends these two-dimensional forms by translation or rotation, three-dimensional shapes occur like an ellipsoid (including sphere), (one- or two-shell) hyperboloid, paraboloid, hyperbolic paraboloid, conoid, helicoid (Figure 24). In some early projects Antoni Gaudí (1852-1926) used such geometric shapes in its elementary forms, Zaha intended to develop such complex geometric shapes and used them widely in her projects, as it's clearly noticed in Serpentine Sackler Gallery in Lodon, Regium Waterfront in Reggio Calabria, Italy and London Aquatics Centre (KIZILTEPE, 2015).

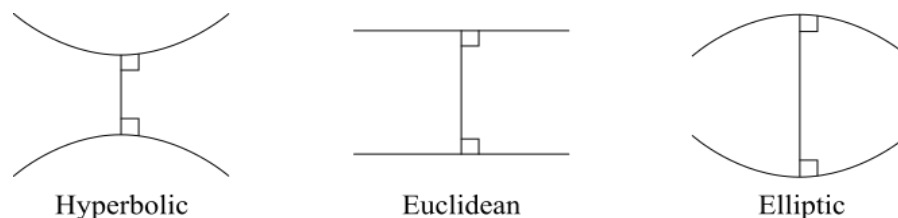

Figure 24: three geometrical types of quadric surface (Tomlow, 1989)

## **Chapter 3**

### **ANALYSIS OF ZAHA HADID ARCHITECTURE**

#### **3.1 Method for analysis of Zaha Hadid Architecture**

In this section, seven of Zaha Hadid's works are analysed and documented with the three main issues derived from the literature review to be analyzed are: techniques in design, form pattern, and the formative ideas that make them iconic. Each building is analysed both on the techniques used in the cases and the attendant form pattern. The cases are recorded on two adjacent pages: the first page which is named as factual drawings documents the building with name, date, size, and location as well as drawings of the site plan, floor plans, elevations, and sections; illustrated on the other pages is a series of five analytical diagrams. A major concern of the analysis is to investigate the formative ideas in her buildings. To satisfy this concern, five issues of formative ideas were selected from the widest range of characteristics, also the essential elements shared by all buildings and relationship between the elements. Each issue is first explored in isolation, then in relation to the other issues. This information is studied to discern reinforcement and to identify the dominant underlying idea. Meanwhile, formative design ideas including Massing, Balance, Plan to section/elevation relationship, Repetitive to unique, and Geometry came together with the design technique and form pattern to attain the objective of the research.

**Design techniques:** As mentioned earlier in section 2.1, as an ardent observer of nature, architecture, and art, Hadid tends to seek out their aesthetic sources and the characteristics that give them their appeal so as to apply them in her work. Her zeal has helped her to acquire certain skills which she has diligently developed into her personal technique. Hadid's architectural style defies established norms, defies limitation, and results in that previously considered to be impossible. As a result according to many people, her buildings nowadays are considered as one of the most attractive architectural styles in the world. In this part the techniques which are mainly fragmentation and abstraction, layering, seamlessness and fluidity, play of light, and landscaping the surroundings, are to be indicated in the selected buildings.

**Patterns of form:** Based on the prevailing characteristics of building and Hadid's description of the notion, some patterns have been identified. It has been noticed that she frequently works within five dominant patterns. They could be appraised and identified based on the prominent features of the projects, which are categorized under different well-known form configurations not in architecture but the other domains of life like nature. Hadid's patterns in designing form are Suprematist, topographic, fluid, organic, and parametric forms. What follows demonstrates the features of these prevailing patterns, which are arranged chronologically according to their appearance.

**Formative ideas:** In the third stage of analysis the buildings are reinterpreted with the developed graphic language for further understanding of formative design ideas by referring to five issues which are : geometry, balance and symmetry, massing, repetitive to unique, and the relationship between plan and section/elevations. Therefore the certain principles selected from the study of Clark and Pause in *Principles in Architecture*, these are the principles highly related with formal analysis

of buildings this is why they have selected for this study. For further understanding and representation of formal design ideas, a certain graphic language is developed (table 3) for analytical diagram.

**Iconicity:** This part is a brief conclusion for each case by considering formative ideas, form pattern and techniques, while highlighting the most important principles of iconicity in every case is the main goal for this section in an attempt to attain the objective of the research.

### **3.2 Criteria for the Selection of Cases**

Zaha Hadid designed numerous buildings and objects. According to her official website Zaha Hadid architects, she designed more than 900 buildings, 80 of them are completed. In this study a very limited selection is to be used for highlighting the basic techniques and patterns of form and generic design ideas of her which might be felt in other numerous buildings of her or the one inspired from. (Table 2)

The criteria for selecting the cases are:

















- The most innovative buildings according to its time.
- The building from different design stages of her career.
- The awarded buildings.
- The buildings purely symbolize the pattern

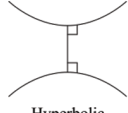
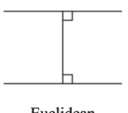
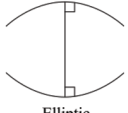

Table 2: Chosen case studies according to the selection criteria's. Source: by Author

CASE S	PROJECT NAME	Year	Function	Location	Awards
CASE 01	<b>Heydar Aliyev Cultural Center</b>	2012	Cultural Center	Azerbaijan	Architizer A+ Award Design of the year 2014
CASE 02	<b>Dongdaemun Design Plaza</b>	2014	Plaza	South Korea	SEGD merit award
CASE 03	<b>Library and learning center of Economics Vienna</b>	2013	Library	Vienna	RIBA Award European Union
CASE 04	<b>Galaxy SoHo</b>	2012	Office, retail and entertainment complex	SoHo, Beijing, China	Arch. Society of China CASC silver award Best public space award CIDA RIBA international award RIBA Lubetkin prize shortlisted
CASE 05	<b>Innovation Tower; Jockey Club</b>	2014	University	Hong Kong	CTBUH 2014 Best tall buildings Award finalist Structural excellence award HK, Commendation of Merit 2014
CASE 06	<b>MAXXI Museum</b>	2009	Museum	Rome, Italy	Innovation and design award, Conde Nast 2010 RIBA Award (European Union) 2010 RIBA Stirling Prize Maxxi Museum 2010 WAF World business of the year 2010
CASE 07	<b>Vitra fire station</b>	1993	Fire station	Rhein, Germany	The project that made Hadid famous

Table 3: Graphic language developed for analysis of formative ideas. Source: author

<p>  MAJOR MASSING   SECONDARY MASSING         </p> <p style="text-align: right;">MASSING</p>	<p>  SYMMETRY   OVERALL BALANCE   LOCAL BALANCE   DUALITY         </p> <p style="text-align: right;">SYMMETRY &amp; BALANCE</p>
<p>  RELATED CONFIGURATION   REMINDER OF THE BUILDING         </p> <p style="text-align: right;">PLAN - SECTION/ELEVATION RELATIOSHIP</p>	
<p>  HYPERBOLIC   EUCLIDEAN   ELLIPTIC         </p> <p>  SQUARE     RECTANGLE         </p> <p style="text-align: center;">           QUADRIC SURFACE:   Hyperbolic     Euclidean     Elliptic         </p> <p style="text-align: right;">GEOMETRY</p>	
<p>  UNIQUE   REPETITIVE   REMINDER OF THE BUILDING         </p> <p style="text-align: right;">REPETITIVE TO UNIQUE</p>	

### **3.3 Analysis of the Selected Buildings**

In this section, seven of Zaha Hadid's works are analyzed and documented for understanding form patterns, design techniques formative ideas and iconicity. The buildings are Heydar Aliyev Cultural Center in Baku -2012, Dongdaemun Design Plaza in Seoul- 2013, Library and Learning Center of Economics Vienna - 2012, Galaxy SoHo in Beijing - 2012, Innovation Tower; Jockey Club in Hong Kong - 2013, MAXXI Museum of XXI century Arts in Rome - 2009, Vritra fire station in Germany -1993

#### **3.3.1 Heydar Aliyev Cultural Center, Baku, 2012**

The Heydar Aliyev Centre is Azerbaijan's first cultural center. Construction on the center began in 2007 and was completed on the 10<sup>th</sup> of May, 2012, just in time for celebrations of the 89<sup>th</sup> anniversary of the late national leader's death in Baku. Considered one of the world's foremost architectural pieces, the center quickly became a signature landmark of modern Baku. The Centre is not only Azerbaijan's first Cultural Center but, with its 56,000 m<sup>2</sup>, it is also the largest center of its kind in the Caucasus and Middle-Asian region.

##### **3.3.1.1 Design Techniques in Heydar Aliyev Cultural Center**

**Landscaping the Surroundings:** Landscaping the Surroundings is a paramount technique Zaha Hadid strikingly employed in HACC. Playing with the topography, extending wall, vanishing, elevating the ground floor and use of single color in the building are the basic landscaping techniques. Hadid achieved to integrate HACC into the already existing urban environment. By making it a complementary part of the site. Its embedded and melted within the context by taking into account various articulated relationships between the building and environment through a harmonic attitude. The articulated lines comes from the building vanishes toward the outside

as if the building comes out from the land (Figure 25).



Figure 25: general view which illustrates landscaping techniques in HACC. Source: <http://www.zaha-hadid.com>

**Seamlessness and Fluidity in the Heydar Aliyev Cultural Center:** The steel curves creates an extraordinary formation out of 90 degree corners in HACC, the curving surfaces gives the sense of continues fluid space. In effect the fluid spaces let the people to move from one place to another unconsciously. The inclined surfaces toward inside and outside creates sudden shocks and surprises for the visitors. The exposed surfaces permit the light to enter the building (Figure 26).

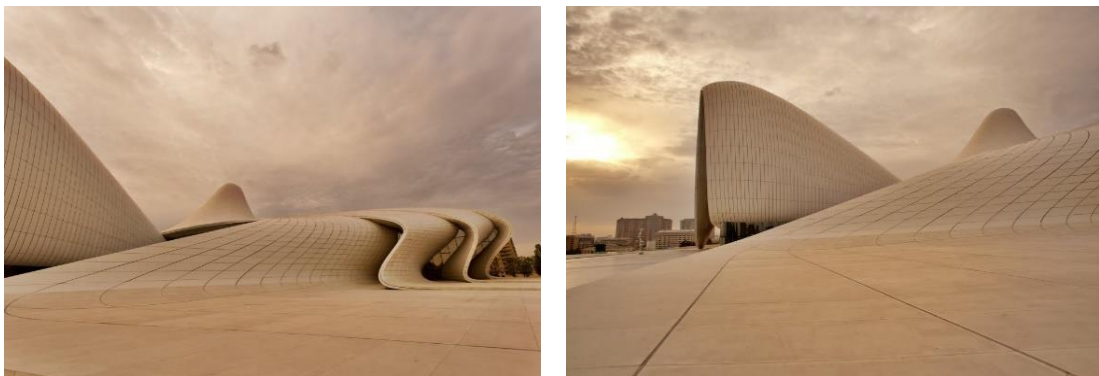

Figure 26: the seamlessness and fluidity of Heydar Aliyev Cultural Center. Source: <http://www.zaha-hadid.com>

**Abstraction and fragmentation in Heydar Aliyev Cultural Center:** The volumes and geometrical forms are organized by aggregation. The forms are fragmented and porous. Which are all made an organizational pattern implying a new geometry. Changed and bended lines for creating effects light and shadows on form and spaces. The Melting technique, as an abstraction used in the project, emerges through the rises of gradually building from zero with smooth curves and form the building shape (Figure 27).

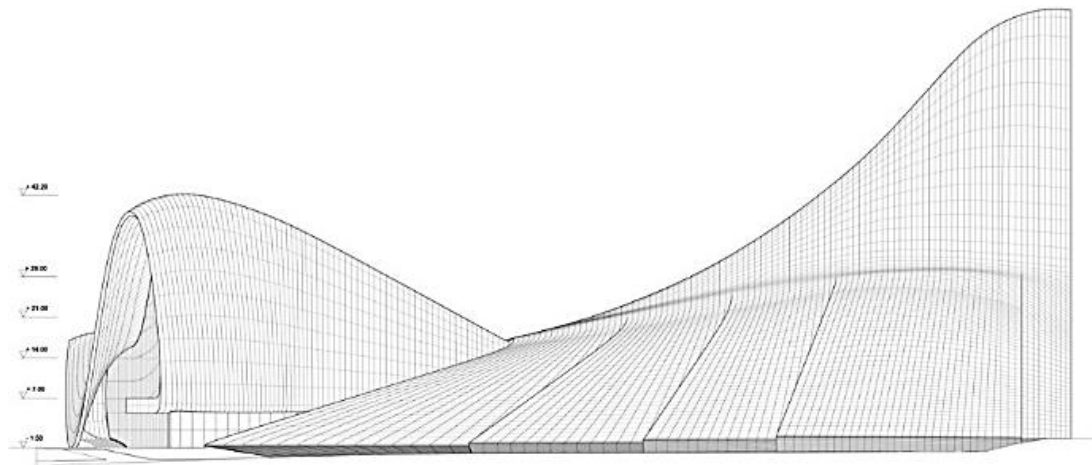

Figure 27: South-East elevation of Heydar Aliyev center illustrates the melting technique

**Play of light & masses in Heydar Aliyev Cultural Center:** Hadid considered strongly the impact of light in interior space of HACC as well as manners and elevations. Accordingly, she develops certain techniques by considering 3 dimensionality of form and surfaces fir enforcing dramatically spatial qualities. The lighting reacts to the ever-changing 3D geometry and enforces to highlight the building's sculptural quality. State-of-the-art lighting discretely incorporated into the building fabric and creates spatial alternative on both forms and spaces of HACC. The strip lines of the exterior of the lavish lobby that doubles as a meeting point for all the

primary spaces, provides indirect lighting, and models the skin. The strip of masses are manipulated and organized in building juxtaposition. The auditorium, as a full timber structure, is one of the areas where lighting has its biggest impact on the drama of the space. Light emanating out of the overlapping timber fins accentuates the texture of the timber to create a tantalizing spatial experience (Figure 28).

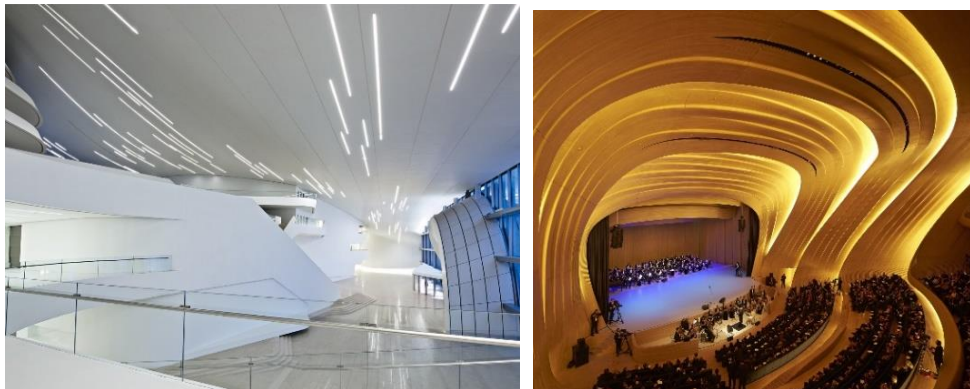

Figure 28: views from the interior of HACC shows both techniques Source: <http://www.zaha-hadid.com>

**Layering** in Heydar Aliyev Cultural Center: layering technique enables Hadid to create amazing voids and spaces and complex fluid surfaces. Amazing fluid interior spaces are manipulated with the interior wall borders. Especially the volumes of the main foyer are clad and pristine in white tiles. Layering technique enabled Hadid to make a great connection between inside and outside of the buildings.



Figure 29: layered curved volumes are clad in pristine, white tiles in Heydar Aliyev Museum Source: <http://www.zaha-hadid.com>

### 3.3.1.2 Form Pattern in Heydar Aliyev Museum

The Heydar Aliyev Cultural Center is categorised under the Topography pattern of form. The notion of its form is by withdrawing landscape of the site into four topographically formed slices, which are merged horizontally to fold again composing the sculpture form of the building (Figure 30). The exterior form is inspired by the natural landscape formation (Site Topography), besides it fades into the earth, giving a sense of affiliation to the site on which it was built.

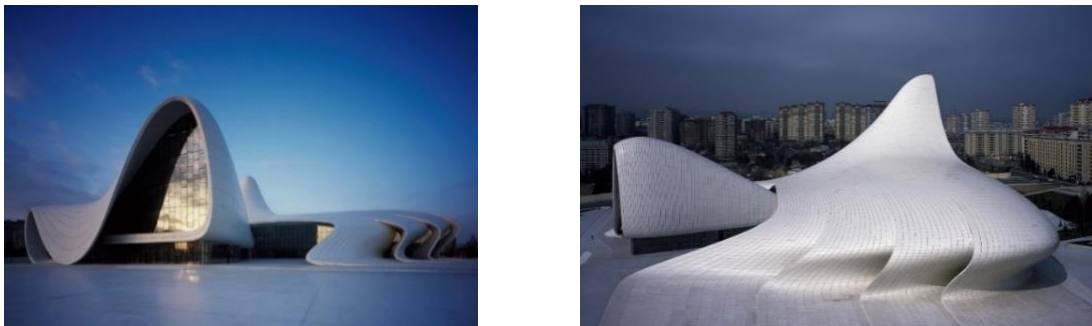

Figure 30: The integration of pavement and wall in Heydar Aliyev Culture Source: <http://www.zaha-hadid.com>

### 3.3.1.3 Formative Ideas in Heydar Aliyev Museum

**Massing:** The integration of the pavement and building walls in the Heydar Aliyev Cultural Center gives a distinctive silhouette. In this project, Hadid attempts to play with one mass, which is the ground by applying the techniques of ground and gravity which explained in section 2.2, to come out with such iconic design.

**Symmetry and Balance:** In the Heydar Aliyev Cultural Center, asymmetrical balance occurs in both the upper part and the lower part, however, there is a local balance between the left side and the related parts as illustrated in the analysis sheets.

**Relationships between plan and elevation** in the Heydar Aliyev Cultural Center: an identifiable correlation between the horizontal and vertical configuration of the cultural center are noticeable. The two realms are influenced from each other and created a dynamism both plan (space) and elevation. The type of relationship between plan and elevation in HACC is defined as analogue as the lines traced in plan resemble of the ones in section.

**Geometry** in Heydar Aliyev Cultural Center: Heydar Aliyev Cultural Center rises from the landscape and folds along a single, continuous surface to form the building revolutionary geometric form incorporated with the parametric design concerns. The Stirling fluctuated surfaces is perceptible and identifiable both with the hyperbolic and elliptical components as show in analytical drawings of HAAC.

**Repetitive to unique** in the Heydar Aliyev Cultural Center: the one unique fluctuated surface in HACC is having certain repetitive components contributing to the formal qualities of the building. This formative idea of project allows some parts of the building to become distinctive among the other repetitive. The repetitive and the unique elements occur in HACC at the number of varied sizes and levels such as the dominant museum entrance lobby and other repetitive.

In regard to all above comments, iconicity in the HACC could be illustrated through several faces as it became an icon for Baku city as people even go to see building more often than the exhibitions inside it. The unique image of the building comes from its formal design with curves reflects the topography of the site, and utilizes variety of innovative design techniques and construction technology. The boundary between the ground and the building itself, is blurred with the continuous curved steel segments.



As one of the more complex structures ever to have been attempted, the multi-directional roof also forms the building's stairs, walls, and ceilings. Being the first building in such a style easily makes it memorable in the minds of those who see it. The innovative design of the Heydar Aliyev Center building has made it a defining landmark of modern Baku due to its remember able image. Also, the unique style is made possible by technology such as computer simulations of the structure of the building, which made it possible to do things that were previously deemed impossible.



### HAYDAR ALEIVE MUSEUM

BAKU, AZERBAIJAN  
SIZE: 56,000 M2  
YEAR: 2010-2012

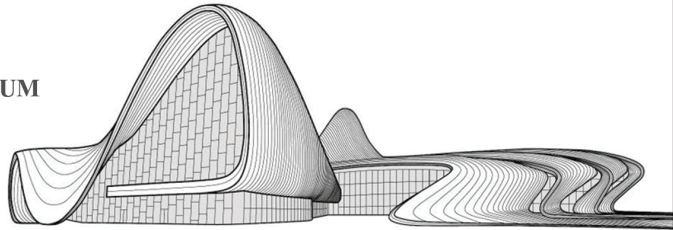

PERSPECTIVE

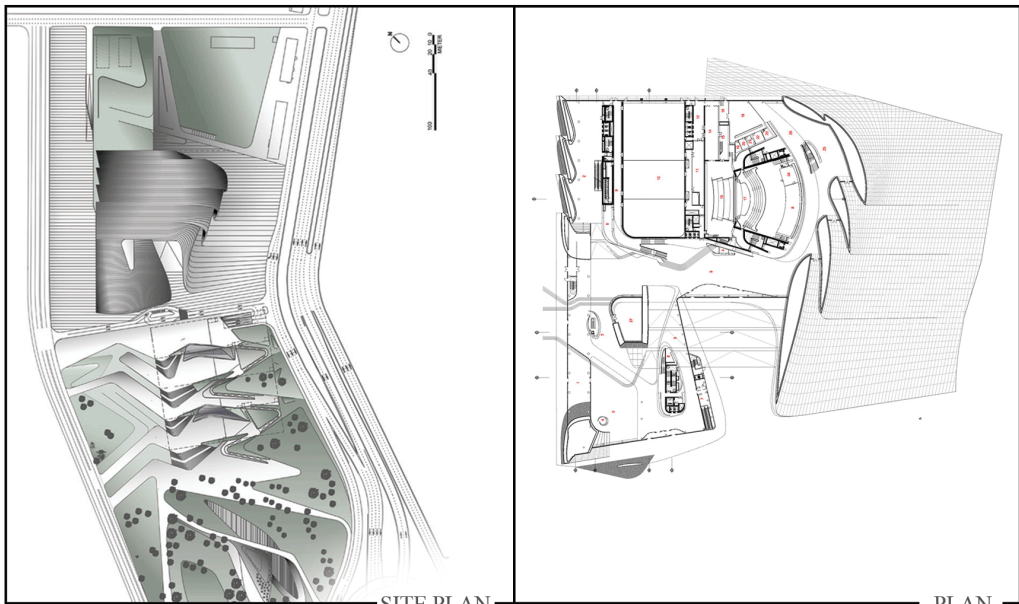

SITE PLAN

PLAN

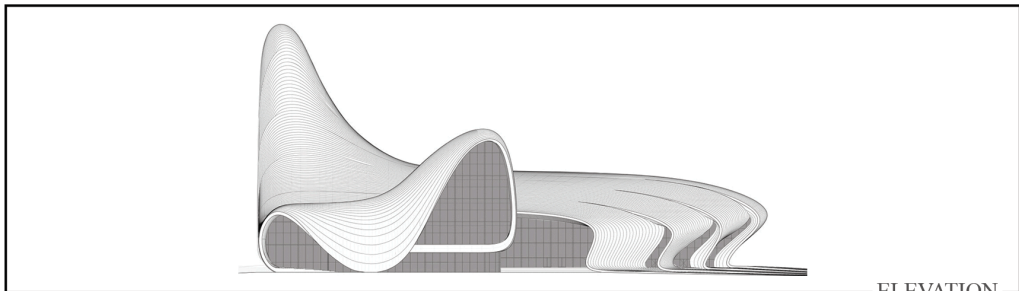

ELEVATION

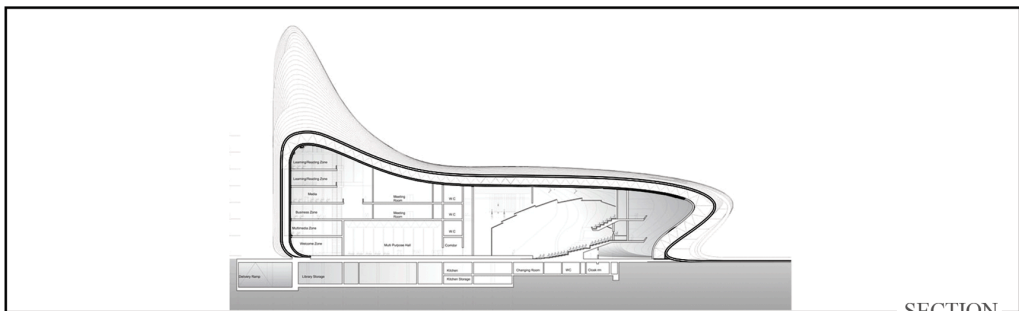

SECTION



**HAYDAR ALEIVE CULTURAL CENTER**

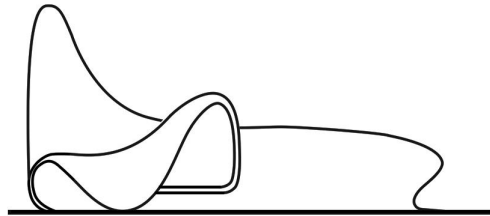

—MASSING

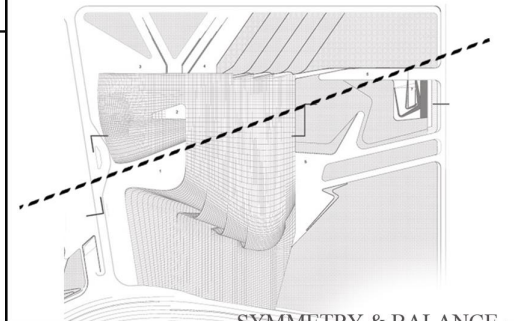

—SYMMETRY & BALANCE

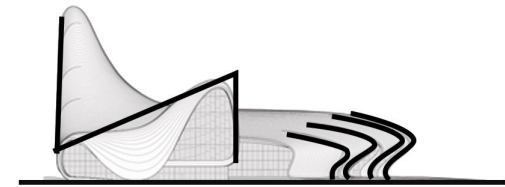
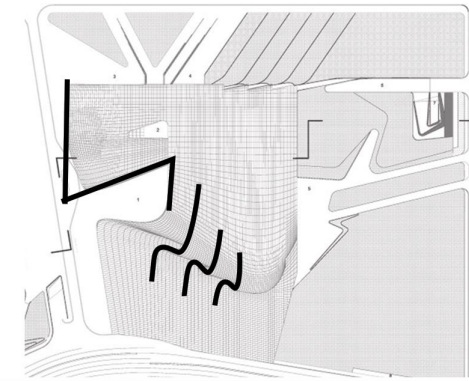

—PLAN - SECTION/ELEVATION RELATIOSHIP

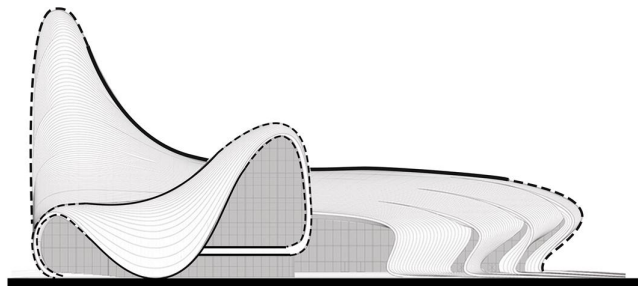

—GEOMETRY

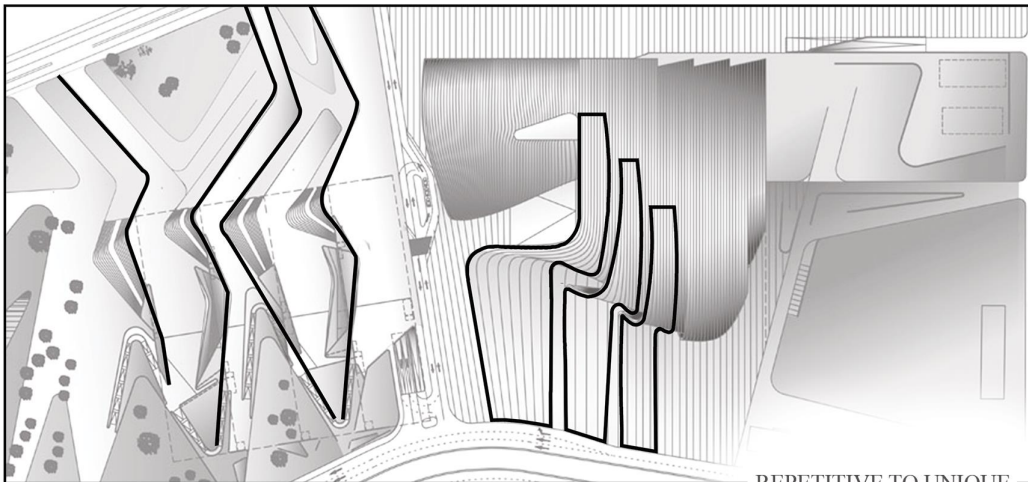

—REPETITIVE TO UNIQUE

### 3.3.2 Dongdaemun Design Plaza, Seoul, 2013

The Dongdaemun Design Plaza, located in Seoul, South Korea, is a cultural center. It comprises a range of public spaces, including a conference hall, art exhibition halls, exhibition hall/design museum, media center, seminar rooms, design labs, designers lounge, and 24-hour design market. The construction of the building was completed in 2013. DDP was the first Korean public project in which 3D Building Information Modelling (BIM) and other digital construction tools were used (Figure 31).



Figure 31: The bird eye view of DDP. Source: <http://www.zaha-hadid.com>

#### 3.3.2.1 Design Techniques in Dongdaemun Design Plaza

**Seamlessness and Fluidity:** The design seamlessly incorporates the plaza and park as one landscape element, obscuring the line between nature and architecture, and converting Seoul into a greener city by folding into the dining and shopping spaces below (Figure 32).



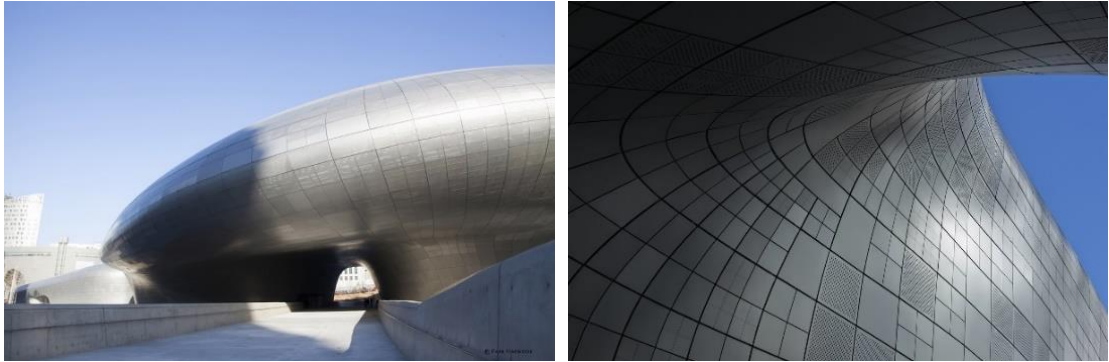

Figure 32: details of the plaza illustrated the melting technique. Source: <http://www.zaha-hadid.com>

**Landscaping the Surroundings:** The Dongdaemun History & Culture Park is downtown Seoul's most recent park. The park alludes to the previous use of the area by the Joseon dynasty as a training ground for its military. The park is particularly distinctive as it extends onto the roof of the DDP (Figure 33).



Figure 33: the figure illustrates the landscaping as a design technique. Source: <http://www.zaha-hadid.com>

**Abstraction and fragmentation:** As discussed in Table 1, this technique could be implemented in several ways; here, the Melting technique as an abstraction is used in the project to regenerate the site and integrate it as much as possible with the surrounding (Figure 34).

**Play of light:** Over forty-thousand micro-perforated aluminum panels were used to clad the DDP building. These panels use their varying curvatures and dimensions to fashion decorative patterns whose texture is inspired by Korean culture. The building's appearance changes significantly between day - when it appears 'solid and metallic' - and night - when the light passing through the micro-holes in the facade somewhat 'dematerialize' it (Figure 34).

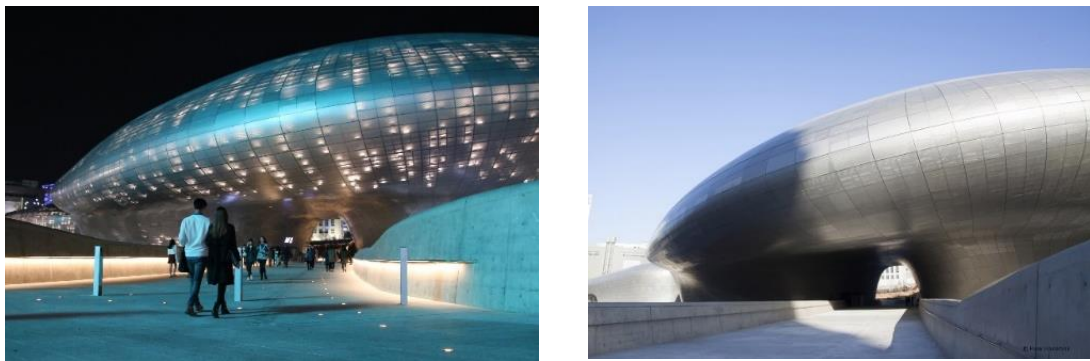

Figure 34: Dongdaemun design plaza, main entrance views, and differences from day and night through play of light technique. Source: <http://www.zaha-hadid.com>

### 3.3.2.2 Form Pattern in Dongdaemun Design Plaza

The design of the Dongdaemun Design Plaza is a mix of parametric pattern with pure organic pattern. The parametric building information modelling (BIM) computer program in conjunction with the computation of design processes allow the building's design to be continually altered based on the client's wishes while accounting for construction and engineering requirements. The process of parametric modeling, in addition to improving workflow efficiency also enabled the architect make cognizant decisions in a limited amount of time which no doubt contributes to the plaza's success overtime.

### **3.3.2.3 Formative Ideas in Dongdaemun Design Plaza**

**Massing** in DDP is achieved using the technique in parametric design, which help to achieve a complex design with simple masses, the building's surface is covered withover forty-thousand micro-perforated aluminum panels of varying curvatures and dimensions. The whole building is formed by three seamlessly connected masses in which rumps are used for transition between the zones and a one huge rump driver's the visitors to the landscaped roof.

**Symmetry and Balance:** In DDP, there are no symmetric parts or equal unities, meanwhile the asymmetrical balance, also called the visual balance, occurs by manipulating area and masses respectively.

**Relationships of a plan to section:** In DDP, there is an identifiable correlation between plan and elevation as illustrated in the analysis part, and this type of relationship, which occurred in the DDP, is categorized as a proportional relationship.

**Geometry:** The plaza's numerous curves are illustrative of Hadid's signature flowing style. The building's façade, which also doubles as its roof, is comprised of about forty-five thousand panels with different curvature degrees and sizes. Furthermore, the geometry of the building is highly complex as its structure is a mixture of steel and concrete; quadric surfaces, including hyperbolic and elliptic as a geometric solution, were used in this project.

**Repetitive to unique** in DDP can be noticed in two different levels: the first one is the huge variety of different dimensions of perforated aluminum panels which are repeated to form the seamless surface; the second is the distinctive landscaping parts which

grow spontaneously to cover the roof of the DDP in different sizes as illustrated in the analysis.

In regard to all above comments, the plaza's design was, to a large extent, based on parametric design and advanced BIM modelling, which helped to sustain the original design objectives over the course of construction. In addition to improving workflow, the parametric modelling process also aided the decision-making processes over the temporally limited construction period thus ensuring the plaza's continuity. Both the form of the plaza and that of the park depend on the ancient wall, which seamlessly incorporates both while simultaneously obscuring the line between nature and architecture and improving Seoul's image as a green city. Lastly, the Dongdaemun History and Culture Park is the newest and most iconic park in South Korea.





**DONGDAEMUN DESIGN PLAZA**

SEOUL, SOUTH KOREA  
SIZE: 65,000 M2  
YEAR: 2007-2013

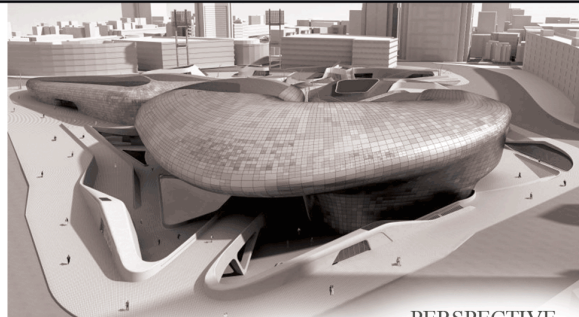

PERSPECTIVE

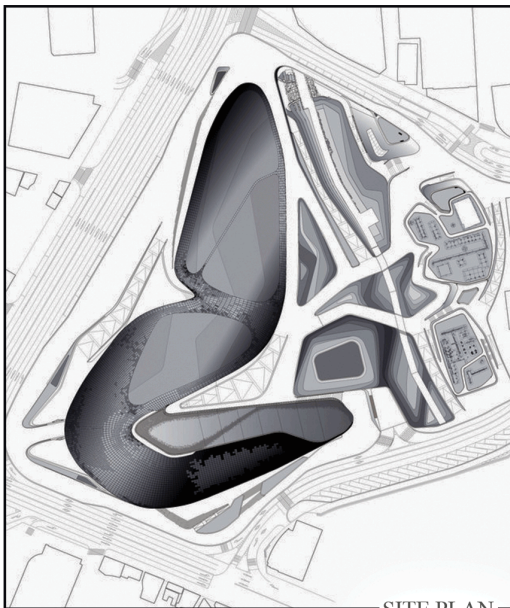

SITE PLAN

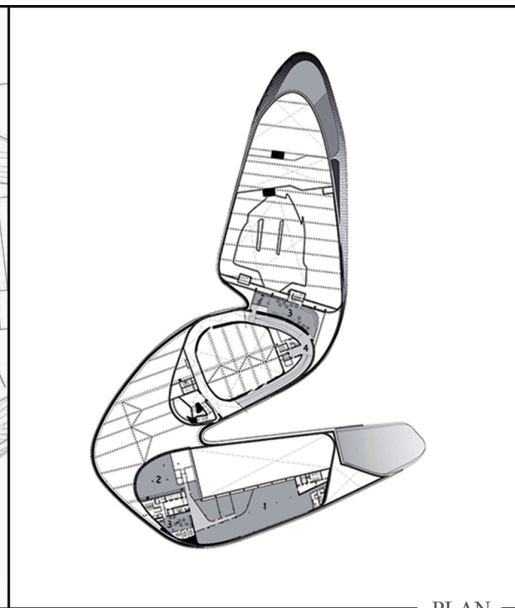

PLAN

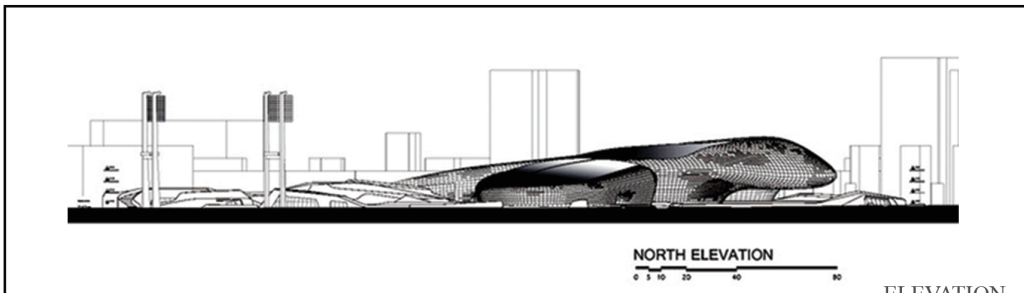

NORTH ELEVATION  
0 10 20 40 80

ELEVATION

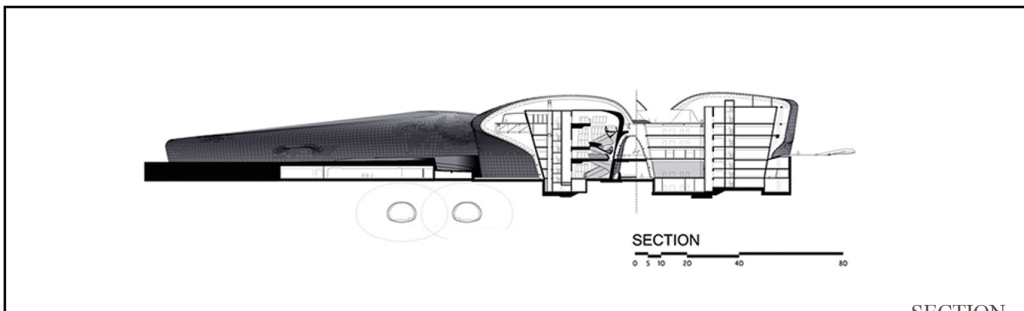

SECTION  
0 10 20 40 80

SECTION

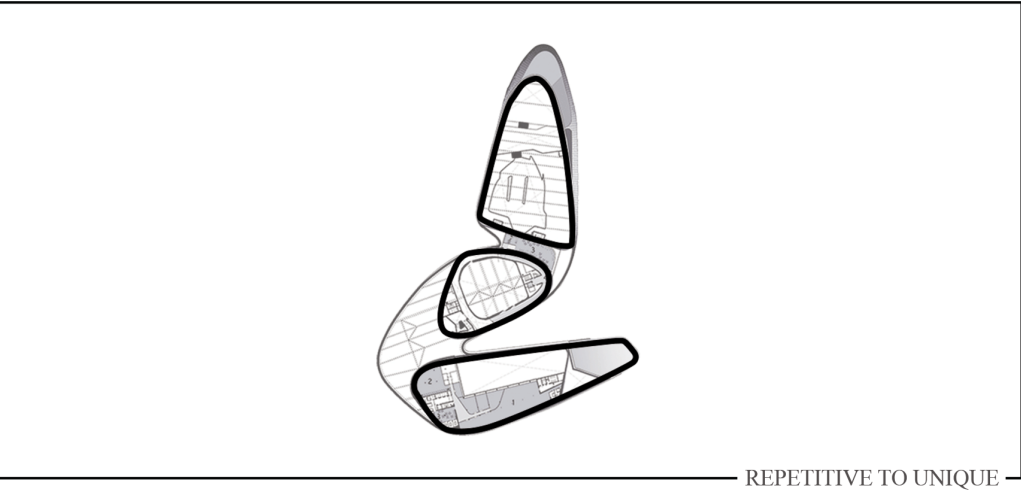
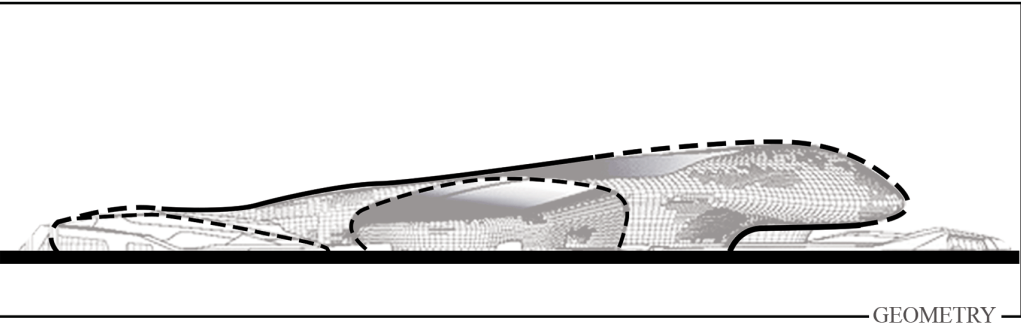
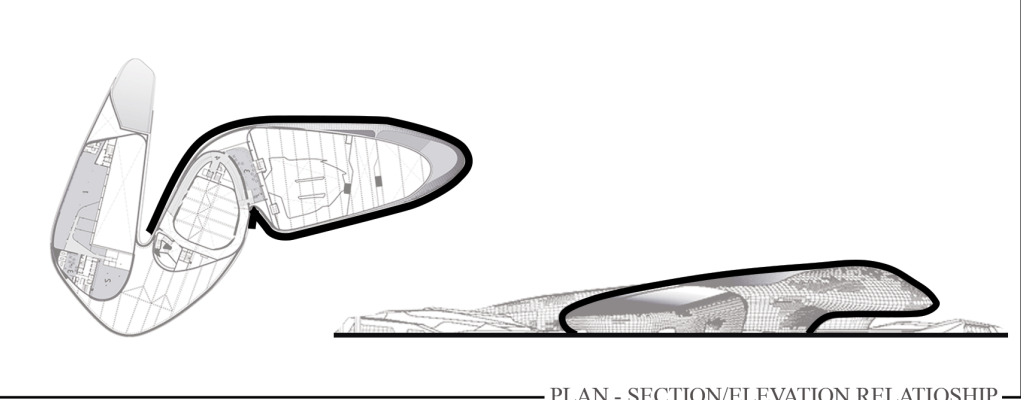
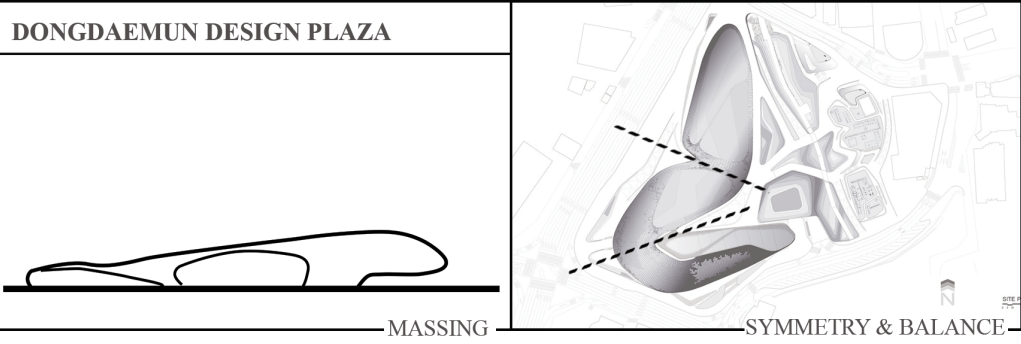

### 3.3.3 Library and Learning Center, Vienna, 2012

One of seven buildings that comprise the Vienna University of Economics and Business' (Wirtschaftsuniversität Wien) new campus is the Library and Learning Center, which has a 25,800 capacity (1,800 staff and 24,000 students). The construction took almost 4 years and was completed in 2012.

#### 3.3.3.1 Design Techniques in Library and Learning Center

**Defying gravity:** Using ideas of ground and gravity technique through the inclination of masses and columns besides the mass cantilever that represents the main part of the building; a number of the façades are tilted up at a 35 degree angle as shown in the (figure 35).



Figure 35: views from LLC, the inclination degree in perspective view in which tilted up to 35 degrees. Source: Dezeen

**Abstraction and fragmentation:** The volume of the building is directed outwards of the site in a sequence of polyhedral, the forward inclination of which is intended to signify aerodynamics. In contrast to the strait exterior, the glazed public spaces curve through the building's solid mass. Organic-looking forms help institute a sense of movement within the multistory lobby. Similar to the landscape of an ocean, the curvilinear walls, which are perforated by walkways and unconventional ribbon

windows for a reef-like effect, appear to have been smoothed by erosion. Deep structural ribs in the glazing undulate away from the walls while the appearance of an organic environment is bolstered by stratified floor plates (Figure 36).

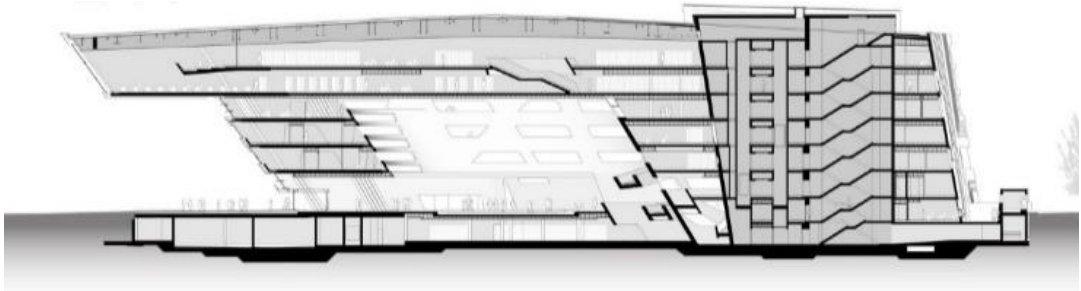

Figure 36: longitudinal section of LLC illustrates the inclined walls, mass cantilever and multistory atrium. Source <http://www.zaha-hadid.com>

**Play of light:** One of Hadid's most frequently used techniques is the play of masses under the factor of daylight whereby motion and life are added to the elevation by a shadow element. The play on masses in the LLC was achieved through the buckling of different surfaces, which could be generally obtained by Accumulation or Superposition (Figure 37).



Figure 37: Night perspective view of LLC building, Accumulation or Superposition techniques used. Source <http://www.zaha-hadid.com>



**Reflecting Project's Form in the Interior Design of Space:** The LLC's interior follows the outside circulation of the master-plan where the various levels of building are mapped out. The building's straight exterior lines begin to separate as they move inwards and begin to become more fluid and curvilinear as they produce the center's principal public plaza in the form of a freely-formed interior canyon (Figure 38).



Figure 38: Interior views of LLC illustrates the relationship between the interior and exterior designs. Source <http://www.zaha-hadid.com>

### 3.3.3.2 Form Pattern in Library and Learning Center

The LLC emerges from the new campus as a polygonal block. Its design is essentially cupid and is characterized by both inclined and straight edges. The straight lines on the outside begin to separate as they proceed to the interior; they become more fluid and result in a free-form canyon that is also the central public plaza. The center's other facilities are accommodated by one volume that splits into 2 intertwined ribbons to create an enclosed gathering space. The building was developed sloped urban block. The distinct external edges stand in contrast to the interior edges, which appear to be joined together. Two panes – one white and one dark – make up the facades, some of which tilt up at a 35degree angle. This setup distinguishes both primary spaces from the exterior and facilitates orientation. The LLC project is theorized under the Suprematist Pattern (Figure 39).



Figure 39: Birds eye view of LLC project. Source <http://www.zaha-hadid.com>

### 3.3.3.3 Formative Ideas in Library and Learning Center

**Massing:** The Library and Learning Centre is represented as a developed urban block with inclined walls. It stands as a polygonal block which has sloped masses and columns 35 degrees from the center of the university, which makes it an iconic building on the campus.

**Symmetry and Balance:** attaining an outstanding asymmetrically balanced form using simple polygonal masses was the aim of this project. This is attained using the gravity technique by mass cantilevering the main part, as illustrated in the drawings. Despite the occurrence of simple repetition of layering issues in the elevation but it's totally asymmetrical shape.

**Relationships of a plan to section / elevation:** It can be denoted that the plan of the LLC is separated into three different masses, this separation was represented by L shaped streams that divided the building accordingly, meanwhile the same separation is being repeated on a different scale and inclination in the elevation where once again, the separation parts are L shaped transparent units. This type of relationship, which occurred in DDP, is categorized as an analogue relationship.

**Geometry:** The new Library and Learning Centre emerges from the heart of the university campus as a polygonal block. Its interior is guided by the the masterplan, which delimits all of the building's different levels. The straight lines adorning the exterior begin to curve as they progress inwards and produce an interior canyon, the plaza's primary public space, in addition to creating the bridges and corridors that facilitate movement between the building's different levels.

**Repetitive to unique** in the LLC can be noticed from the distinctive elevation in which the unique repetition of L shaped voids represent the transparent glass showing the levels of the building, the masses and voids came together as one unit to show an outstanding view for the project as shown in the analysis diagrams.

In regard to all above comments, it is possible to see the building's lopsided cantilevered roof from a distance as the domineering glass fronted monitor faces Prater Park. Zaha Hadid's creation of a dynamic form to house the Library and Learning Center for Austria's University of Economics and Business in Vienna is a conclusive testimonial to the importance of an academic library.



**LIBRARY AND LEARNING CENTRE  
IN VIENNA**

VIENNA, AUSTRIA  
SIZE: 28,000 M<sup>2</sup>  
YEAR: 2008-2012

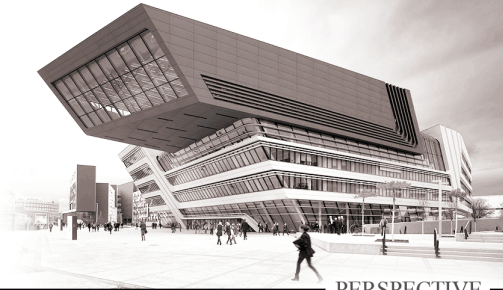

PERSPECTIVE

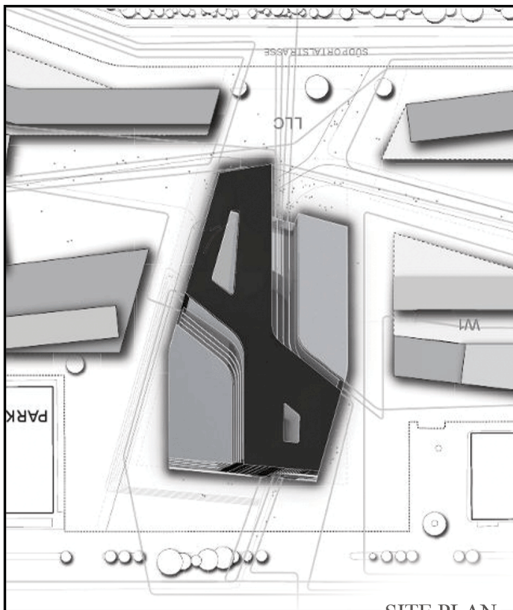

SITE PLAN

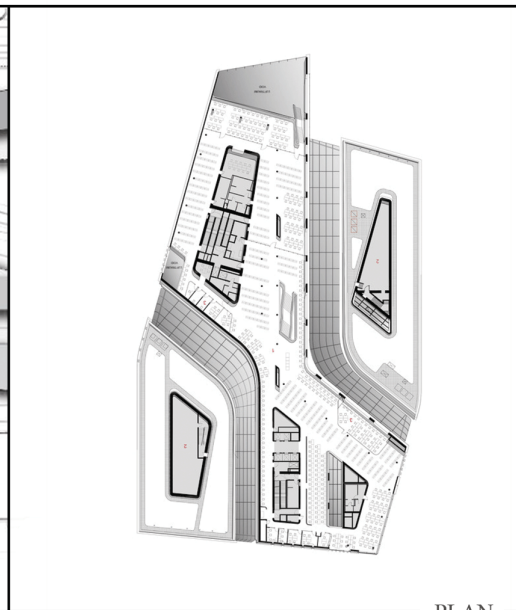

PLAN

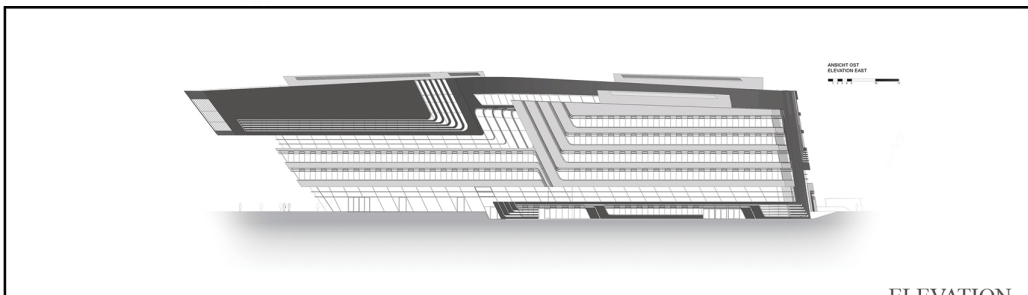

ELEVATION

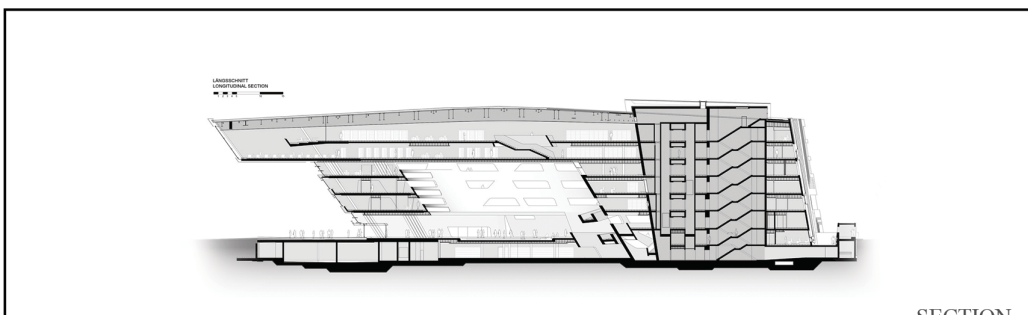

SECTION



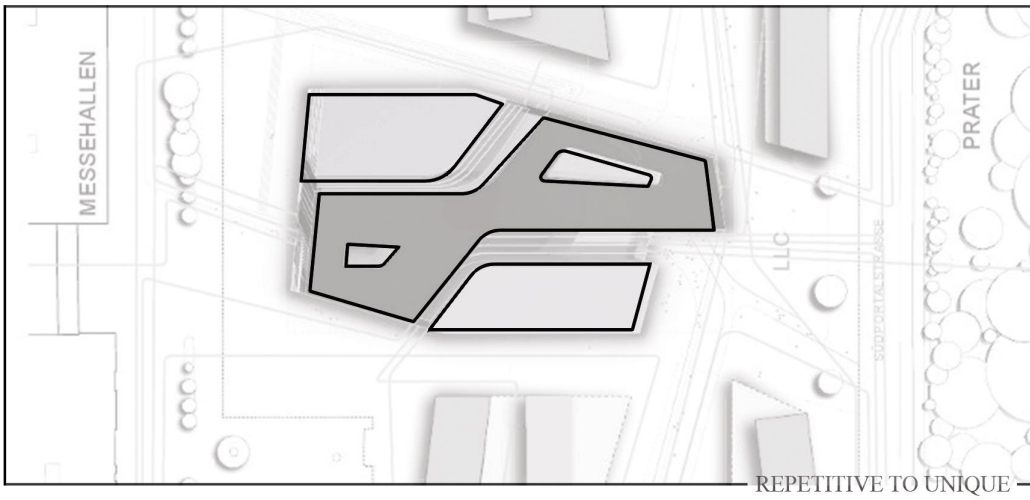
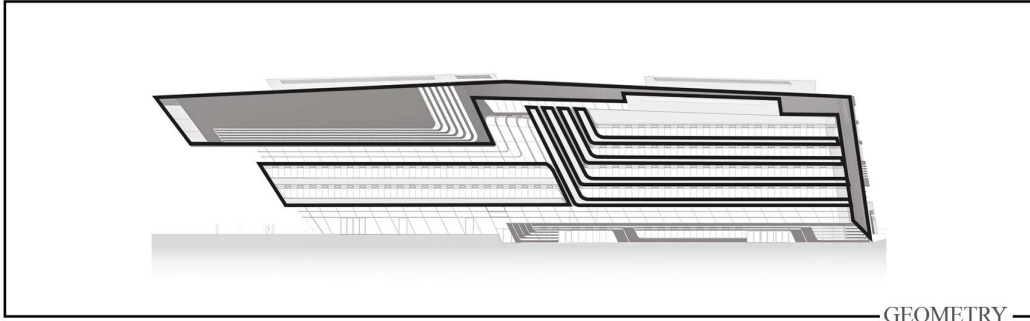
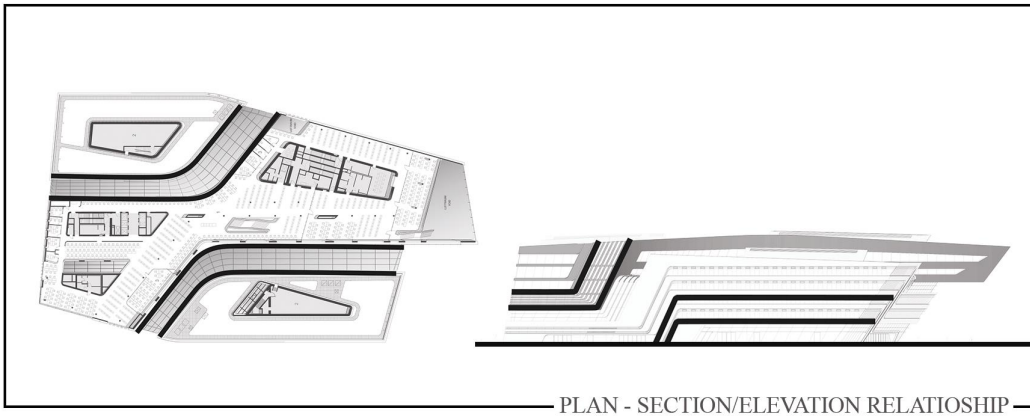
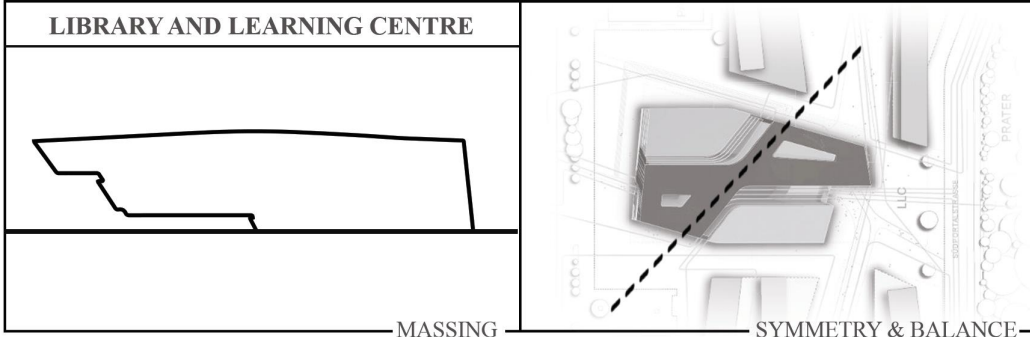

### 3.3.4 Galaxy SoHo, Beijing, 2012

Located in the center of Beijing for SOHO China, the Galaxy SOHO project was completed in 2012 and is almost 332,000m<sup>2</sup> of retail, entertainment, and office complexes. Drawing inspiration from Beijing itself, the center has become a vital part of the city. Galaxy SOHO won the RIBA Award in 2013, and was also one of three projects nominated for the 2014's RIBA Lubetkin Prize.

#### 3.3.4.1 Design Techniques in Galaxy SoHo

**Play of masses:** As previously discussed, buckling, sinuosity, extrusion, abstraction, fragmentation, and making the building porous can all be used to achieve play of masses. In Galaxy SOHO, both buckling and making the building porous were used for terms of playing with the light (Figure 40).



Figure 40: night view of galaxy SoHo illustrates the play of masses technique. Source: <http://www.zaha-hadid.com>

**Layering** allows Hadid create spectacular spaces and voids to meet her expectations of an architectural space. In Galaxy SOHO, the kaleidoscopic plateaus move multiple

levels into view of each other to create an immersive experience with the stimulating environment. The architecture of the building unfolds above and below into layers moving in different directions with a degree of multilevel curve-linearity (Figure 41).



Figure 41: the layering technique through shifting and moving plateaus.

Source: <http://www.skyscrapercity.com>

**Seamlessness and fluidity:** The architects created a series of public spaces to engage with the city directly and reinvent the conventional urban fabric and patterns of living as a nature-inspired seamless urban landscape. The volumes generate a panoramic view lacking any sudden transitions or corners that interrupt its fluidity by adapting to one another in all directions. They cooperate to produce a seemingly continuous mutually-adapting fluid movement between each of the building (Figure 42, 43).



Figure 42: a view of Galaxy SoHo shows the fluid connection between the bridge and elliptical forms. Source: <http://zyn-e.blogspot.com.cy/2014/05/>

Zaha Hadid also considered local characteristics of architecture in Galaxy SoHo and used a concept of design fashioning the interior world reminiscent of a Chinese courtyard. Besides blurring the lines between exterior and interior in Galaxy SOHO, it also reflects the exterior form to the interior and vice versa.

#### **3.3.4.2 Form Pattern in Galaxy SoHo**

The form pattern of this building complex is created in a synthetic digital space and it is a spectacular example of parametric design. The form is inspired by cultivable terraces typical of the Chinese mountainous landscape and the context of the city. Discussing the project, Zaha Hadid said: “The design responds to the varied contextual relationships and dynamic conditions of Beijing. We have created a variety of public spaces that directly engage with the city, reinterpreting the traditional urban fabric and contemporary living patterns into a seamless urban landscape inspired by nature”. The architecture of the building comprises 5 flowing volumes linked to one another by stretched bridges. Each of the volumes adapts to the others in all directions which serves to enhance the panoramic dimension of the overall architecture in the absence of corner to disrupt the structure’s fluidity (Figure 43).



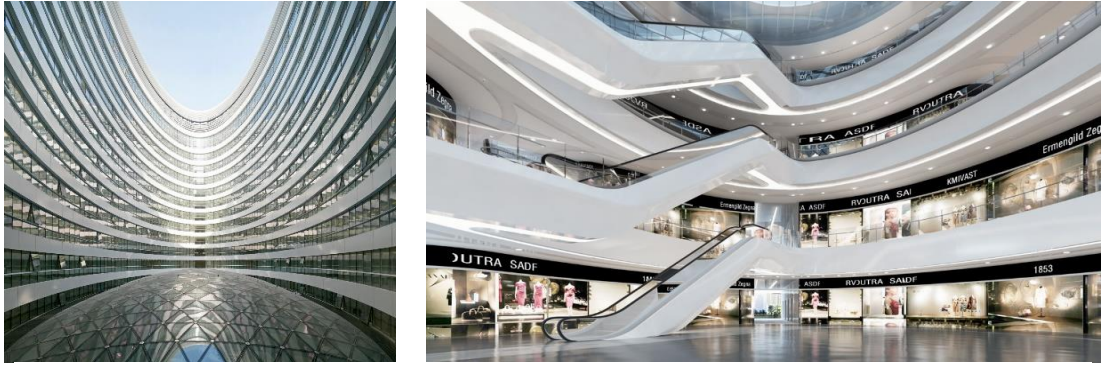

Figure 43: The inner courtyard and leveling of Galaxy SoHo shows the strong connection between interior and exterior design. Source: <http://www.archdaily.com>

### 3.3.4.3 Formative Ideas in Galaxy SoHo

**Massing** in Galaxy SoHo is a composition of several continuous volumes joined via stretched bridges. The volumes acclimate to one another regardless of direction, thus resulting in a panoramic piece that lacks any abrupt transitions that break its compositional fluidity.

**Symmetry and Balance:** In Galaxy SoHo, there are five different oval shaped masses which are connected by bridges, there is an overall balance between the projects masses with a semi occurrence of symmetric parts in individual buildings or equal units but in general, the masses are totally asymmetric.

**Relationships of a plan to section:** the plan of Galaxy SoHo entails differently sized elliptic shapes connected with bridges giving a seamlessness continuous shape. The elevation is a representation of a semi-elliptic shape with the occurrence of bridges intersected with the shapes in a fluid motion. So, the analogue relationship can be identified in the comparison between both plan and section.

**Geometry:** in Galaxy SoHo project quadric surfaces are used for designing overall buildings. Quadric surfaces including both hyperbolic and elliptic as a geometric solution used in this project. In the illustration part the dashed lines represent the elliptical edges and the bold lines represent the hyperbolic edges.

**Repetitive to unique:** the repetition of elliptic-shaped masses within the inner courtyards in different sizes and dimensions in the site plan, besides the repetition of the layers in each elliptic mass, gave the project an outstanding and unique form. Also, the elliptical masses were connected to each other on some levels, whenever the elliptical masses come together with the bridge in a fluid connection, it shows the originality of the design.

In regard to all above comments, one of the design concepts of the project aimed to replicate the interior of a Chinese courtyard. Regardless, the design is extremely modern. It involves the use of malleable volumes as opposed to inflexible blocks and the space between them. These volumes fuse, coalesce, connect, and pull apart via numerous stretched bridges so as to allow for fluid movement and synchronized adaptation.

Inspiration for the other design concept was drawn from the ancient terraced Chinese rice fields. With a basis in nature, parametric design entails an amalgamation of the natural landscape and modern digital technology. The different flowing plateaus represent mountain-based rice field, connect the volumes, and contribute to the urban landscape.

It is a 360-degree piece of architecture without any corners and disruptions, just seamless evolution. The Galaxy SOHO obscures the lines between the interior and exterior, form and function, beauty and curiosity, and entices the visitor to its seemingly extraterrestrial experience. Lying between the buildings' sweeping overhead curves and busied by numerous bridges, the canyon is the central open air space and location of most activities.



## GALAXY SOHO

BEIJING, CHINA  
SIZE: 332,857 M<sup>2</sup>  
YEAR: 2009-2012



PERSPECTIVE



SITE PLAN

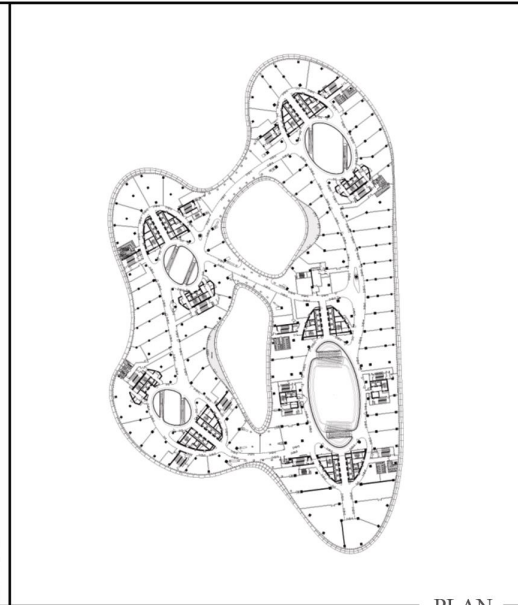

PLAN

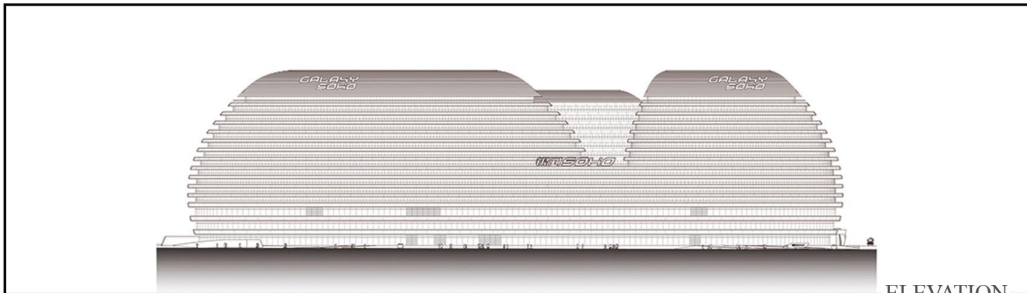

ELEVATION

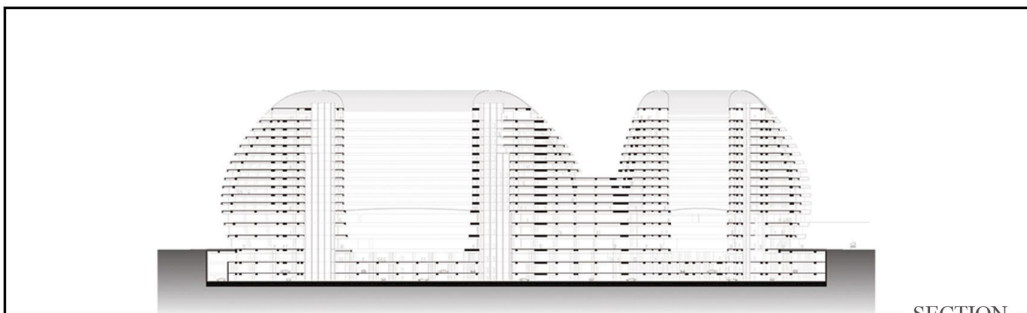

SECTION





**GALAXY SOHO**

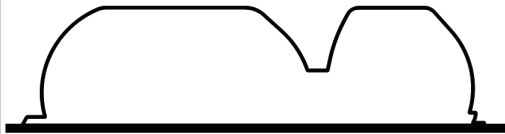

— MASSING

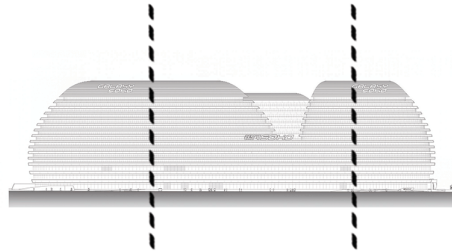

— SYMMETRY & BALANCE

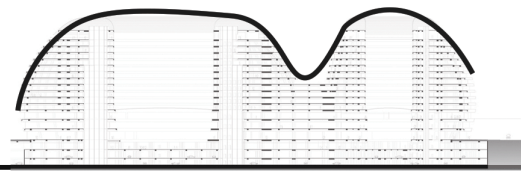
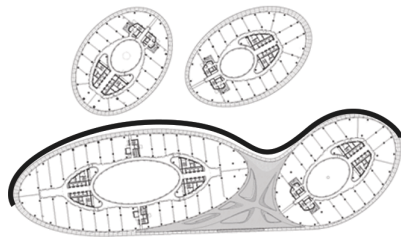

— PLAN - SECTION/ELEVATION RELATIOSHIP

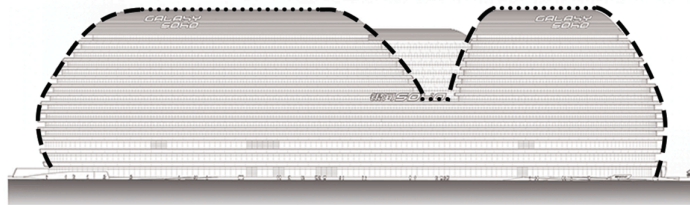
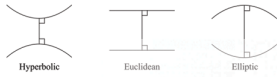

— GEOMETRY

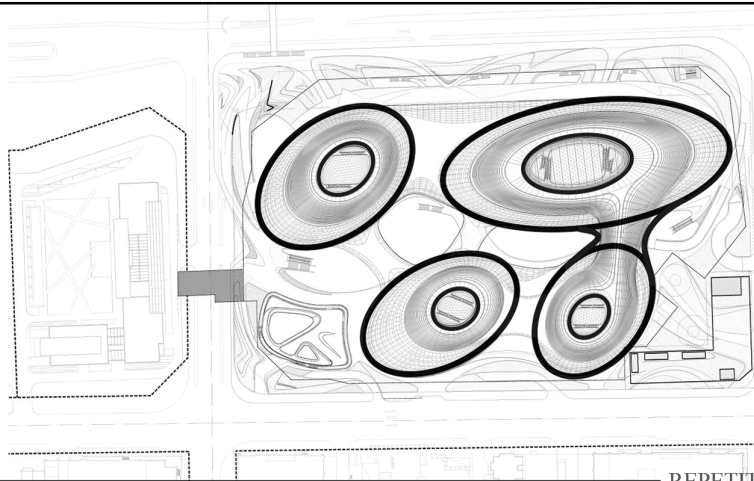

— REPETITIVE TO UNIQUE

### 3.3.5 Innovation Tower; Jockey Club, Hong Kong, 2014

Housing the Jockey Club Design Institute for Social Innovation and the Hong Kong Polytechnic University (PolyU) School of Design, the Jockey Club Innovation Tower (JCIT) is a 15000 m<sup>2</sup> fifteen-story structure that holds over 1,800 staff and students. The tower is comprised of various innovation and design education facilities including labs and workshops, design studios, multi-functional classrooms, exhibition areas, a communal lounge, and lecture theatre. The construction finished in mid-2013 and the building won the RIBA award for international excellence in 2014.

#### 3.3.5.1 Design Techniques in Innovation Tower; Jockey Club

Several design techniques were used in JCIT and the following are the main techniques used in designing the project:

**Seamlessness and fluidity:** The fluid character is generated through the smooth curved corners and fluid fins through the floor levels, which dissolves the rigidity of the tower into a seamless iconic piece. This fluid external and internal design creates a new image for the campus (Figure 44).



Figure 44: eye level perspective of JCIT, shows the fluid and seamless details of the project. Source: <http://www.archdaily.com>

**Layering** technique in JCIT is purely denoted from the impressive exterior curved 3D façade claddings, which gives a distinctive view from the outside, meanwhile this layer incorporated energy efficient features (Figure 45).



Figure 45: A render of the covering layer which used as shading design of JCIT Source: <http://www.arch2o.com>

### **Using Distorted Addition Technique accompanied with Strong Justified Notion**

A series of external vertical and horizontal fins around the entire building, set at irregular intervals and at less than story heights, confuse the understanding of scale, making the building appear as a homogenous form and taller than it is. Its presence is impressive and it occupies the challenging site extremely well (Figure 46).



Figure 46: A drawings of JCIT illustrates the horizontal fins that stretches alongside the building Source: <https://www.dezeen.com>

**Reflecting Project's Form in the Interior:** Simple for the most part, the interior finishing consists mostly of painted floor finishing and plaster board surfaces. The choice of finishing is easy to maintain and is also fitting for a design school, largely reflecting the exterior form. The building is predominately glazed, giving wonderful views across the city (figure 47).

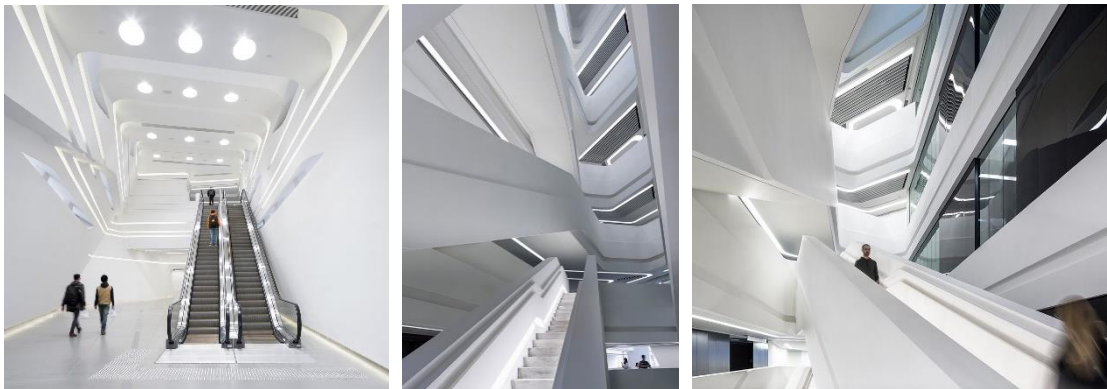

Figure 47: Different views from the interior of the project give the same sense of the exterior of the building Source: <http://www.archdaily.com>

### 3.3.5.2 Form Pattern in Innovation Tower; Jockey Club

The JCIT falls within the suprematism pattern. The building design concept involves an abandonment of conventional practices to give the tower/podium a fluid composition. The courtyards inside and outside are used as informal meeting places to supplement the rather big exhibition forums, recreational facilities, theatre, and studios. A strong and beautiful sculptural base, made from in-situ reinforced concrete, mediates between the ground and the upper glazed stories of the tower forming a plinth over two levels, which deals with a series of complex edge conditions providing opportunities for external terraces around the building (Figure 48).





Figure 48: Bird eye view of Jockey Club innovation tower Source: <http://worldarchitecture.org>

### 3.3.5.3 Formative Ideas in Innovation Tower; Jockey Club

**Massing** in JCIT is represented by two merged polygonal, which are inclined towards the outside area and risen above the Earth level by 73 meters, and a series of external vertical and horizontal fins around the entire building, which are designed individually to make it a distinctive design and an icon for the campus.

**Symmetry and Balance:** In the site plan of JCIT, a semi-symmetrical shape can be noticed in the two main towers, meanwhile, including the other parts of the tower, it became totally asymmetrical with a great occurrence of balance in both sit and elevation.

**Relationships of a plan to section:** In JCIT there is an identifiable correlation between plan and section as shown by bold lines in the analysis part, and this type of relationship, which occurred in JCIT could be categorized as an analogue relationship.

Regarding the **Repetitive to unique** in JCIT, a number of external horizontal and vertical fins around the entire building, set at irregular intervals and at less than story

heights, confuse the understanding of scale, making the building appear as a homogenous form and taller than it is. Repeating such fins on different scales and positions gives the building a unique style as shown in the illustrations below.

**Geometry:** The Jockey Club Innovation Tower rises as two polygonal pieces of blocks from the side of the university campus. The main forms are polygon-shaped and the detailed fins of the elevation are derived from quadric surfaces that are drawn Euclidean to each other as shown in the illustrations below.

In regard to all above comments, with a unique building geometry, Zaha Hadid Architects' design intended for the curved 3D façade by investigating several alternative cladding materials including fiber reinforced plastic, tensile fabric, and aluminum. A unique three dimensional metal cladding is selected. A multiple layer of paneling allows the top layer of cladding to have open joints, while a hidden lower layer provides functional weatherproofing and drainage functions. Three dimensional drafting and Building Information Modelling (BIM) were used to resolve the evolving geometry of the JCIT. Arup performed the role of structural and building services engineer to help materialize the design by Zaha Hadid Architects. BIM was integral to the design and construction of this three-dimension irregularly-shaped building; enabling clash-analysis with building elements and services, providing an efficient mode of communication between the architectural, structural, building services, and facade engineers. The design of the Innovation Tower transforms the classic tower typology into a seamless structure. The design unapologetically tries to present a notion of the future while simultaneously remaining reminiscent of the institution's history.



**INNOVATION TOWER; JOCKEY CLUB**

HONG KONG, HUNG HOM  
SIZE: 15,000 M<sup>2</sup>  
YEAR: 2007-2014



PERSPECTIVE

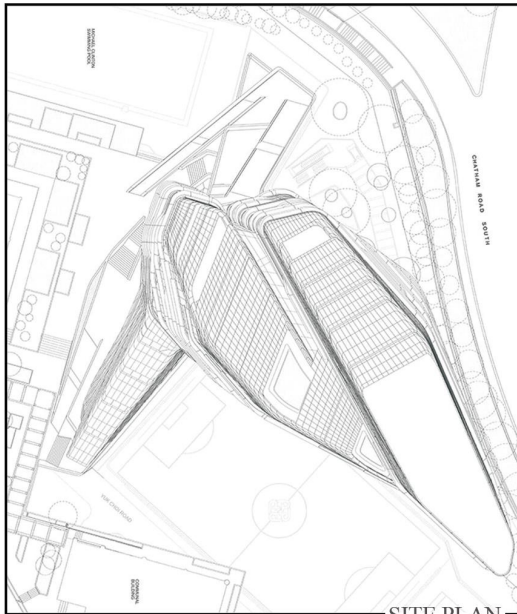

SITE PLAN

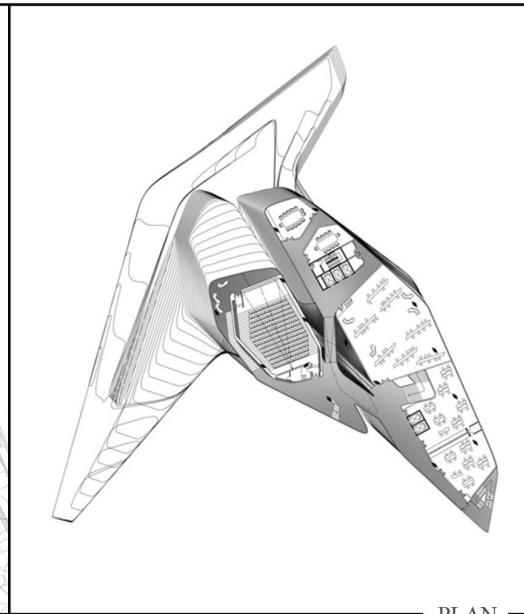

PLAN

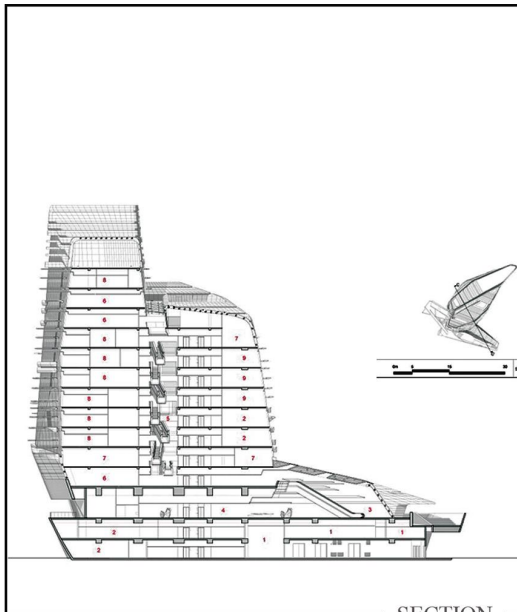

SECTION

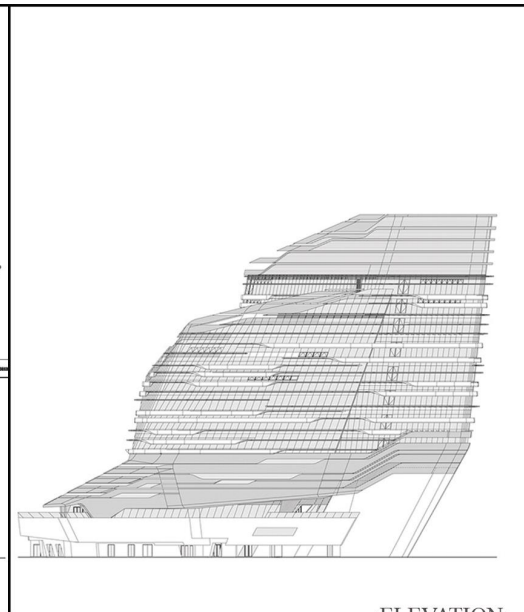

ELEVATION



**INNOVATION TOWER; JOCKEY CLUB**

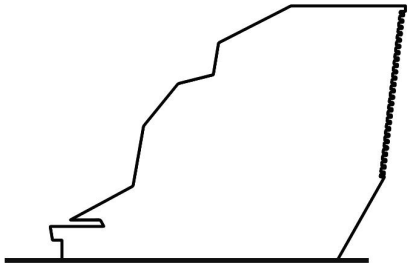

— MASSING —

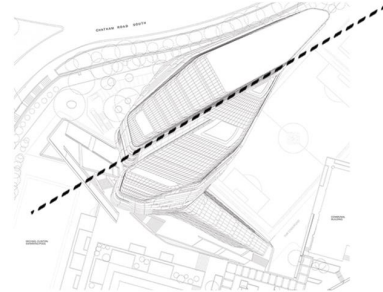

— SYMMETRY & BALANCE —

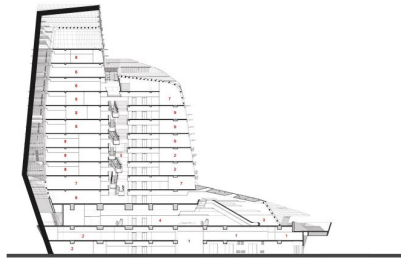
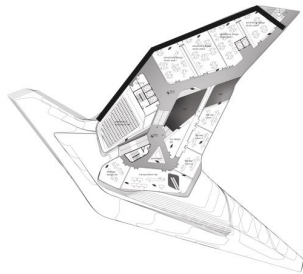

— PLAN - SECTION/ELEVATION RELATIOSHIP —

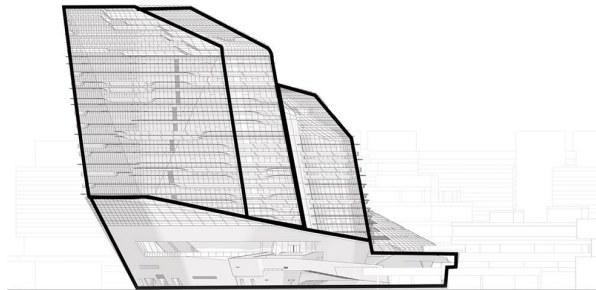

— GEOMETRY —

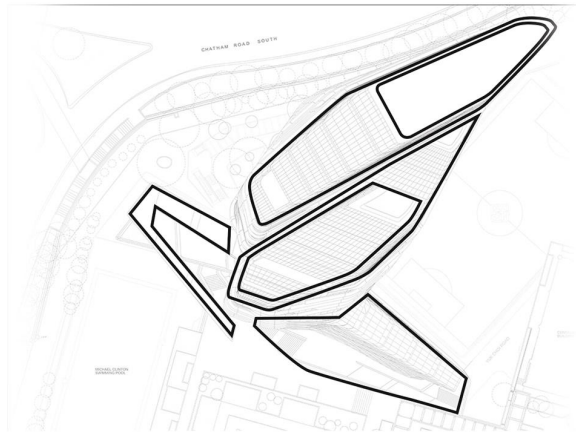

— REPETITIVE TO UNIQUE —



### **3.3.6 MAXXI Museum of XXI century Arts, Rome, 2009**

Zaha Hadid Architects received the mandate to design the MAXXI museum after winning a competition in Roma, Italy in 1998. The museum lies in the city's north in the same low-rise neighborhood as the local barracks. As a relatively new institution, the art collection for the museum is still being compiled. Construction on the site was considerably hampered by a cessation of funding from the Italian government back in 2006/7 although it never completely stopped.

#### **3.3.6.1 Design Techniques in MAXXI Museum**

**Abstraction and fragmentation:** the clear separation of rectangular masses playing beside each other without interrupting the horizontal flow of the building in regards to the surroundings represent pure abstraction and fragmentation in the Maxxi museum. By breaking down the blocks and making them porous through this technique, Zaha added a new geometrical pattern.

**Idea of ground and gravity:** In this project, Hadid ignored the laws of gravity in her design of extended blocks for a deep stand-alone cantilever that is difficult to erect. The Maxxi National Museum in Rome is often used as an example in certain cases because it shows many ideas related to the architectural form of Hadid. An exaggerated cantilever is used to express the technique of ground and gravity (Figure 49).



Figure 49: general view showing the different levels and layering technique in Maxxi Museum project Source: Hadid, 2009

**Layering:** While walls may not always be grounded, the play of walls functions on three main planes, implying that a number of walls function as far-reaching cantilevers or even as long spanning beams. Another set of walls slants downwards, leading to the interior terracing gallery. Elongated, deep beams are the result of the broad openings permitted by the walls. A series of ribs operate in the general laminar flow between the walls and lay emphasis on the gallery spaces' directionality. The layering and intersection of the lines correlates strongly with the vertical connections that allow for movement between levels. Oblique, vertical elements are found at said intersections (Figure 50).

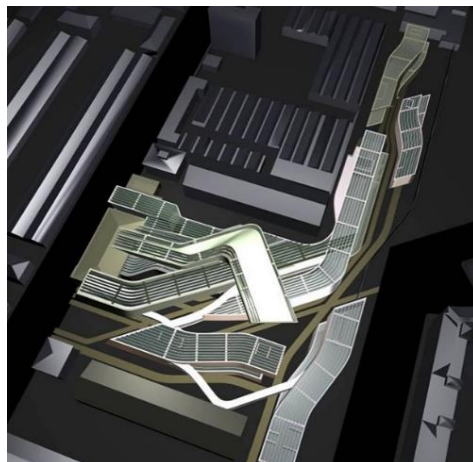

Figure 50: Maxxi Museum illustrating the deep cantilever used as a technique. Source: <http://www.architecturalrecord.com>

**Seamlessness and Fluidity:** The lines used in MAXXI permit the slow process of transforming the resulting field qualities as straight zones morph into curved zones and zones with laminar flow change to zones of intersection and layering. Each of these different qualities is accompanied by a distinct functional implication. In reality, the expectations of the design project have been realized as the structure can be described as a fluid series of spaces that seamlessly switches between relatively simple even flowing zones to multi-layered multi-directional zones (Figure 51).



Figure 51: a view shows the straight masses changes to curved masses seamlessly  
Source: <http://www.archdaily.com>

**Play of light:** This has to do with figuring out what to do with the play of light technique by manipulating building masses. Hadid uses this technique to avoid using cladding and paint for project façade and make it exciting with building materials e.g. concrete, such as the play of masses in Maxxi: National Museum of XXI Century Art in Rome, Italy. The natural light that penetrates through to the gallery spaces is filtered through the ribbed structure of the glass roofs. The design establishes a link between the ribs, walls, and beams, as architectural elements, which join the remaining linear elements, including the staircases, ramps, and even the flow of the museum's audience (Figure 52).



Figure 52: generation a flaw of masses by play of light technique  
Source: <http://www.archdaily.com>

**Reflecting Project's Form in the Interior Design of Space:** The interior and exterior spaces result from the play of parallel walls bolstered by the intersecting wall trajectories. The building's interior presents visitors with number of fascinating views and openings all over the structure. In addition to the use of solid walls to protect its contents, it simultaneously entices visitors to enter the ground floor through its glazed surfaces, which widely reflects the exterior design (Figure 53).

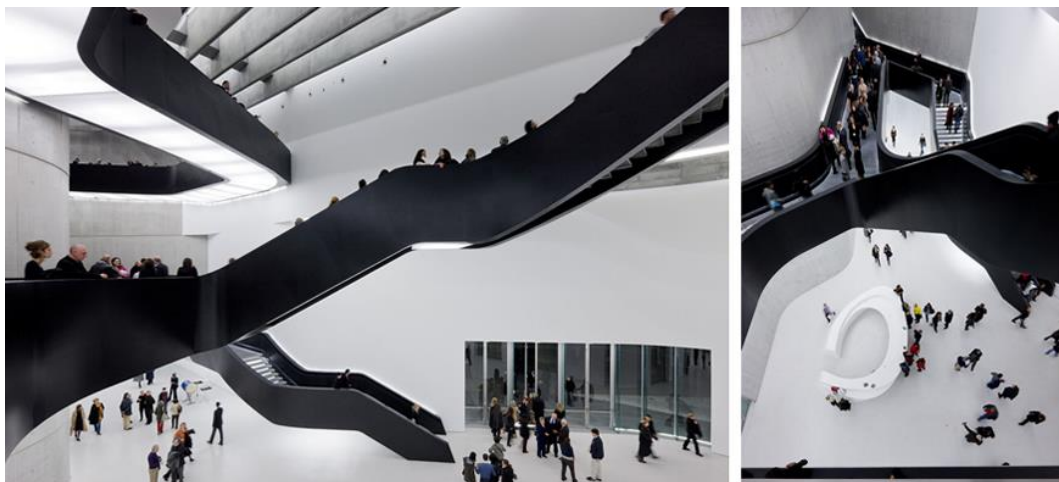

Figure 53: the interior of Maxxi museum reflects the exterior form of flowing the masses. Source: <http://www.archdaily.com>

### 3.3.6.2 Form Pattern in MAXXI Museum

MAXXI Museum is categorized under Suprematist Pattern of form. The museum's form is a sequence of sinuous concrete tunnels interwoven on three levels. The tunnels on the 2<sup>nd</sup> and 3<sup>rd</sup> floors have steel ribs and glass lids; they hold a number of galleries which the museum's curators can easily repurpose.

While the building design is in typical Zaha Hadid fashion, it does draw some inspiration from the surrounding barracks and brick sheds. The primary volume is a 150m-high windy extrusion made from concrete. The intersections of the extrusions result in atria and dramatic voids. Although parallel for the most part, the spacing between the walls changes as a result of the curves that facilitate the change of direction. These curves are also used as an excuse to intersect the walls while maintaining the parallel flow, confluence, and tangential branching. The interior and exterior spaces are the product of the manipulation of the parallel walls in conjunction with intersecting wall trajectories and branching (Figure 54).



Figure 54: Birds eye view of Maxxi museum project showing the parallel masses distributed in the site properly. Source: <http://www.archdaily.com>



### **3.3.6.3 Formative Ideas in MAXXI Museum**

**Massing:** from the analysis of the Maxxi Museum, the massing element can be recognized by the dominance of parallel horizontal masses stretched through the site that turn into an L shape with smooth corners. As shown in the illustration, several horizontal masses flow through the site, intersecting one other by the differentiations in their height level. There are no openings in the side view of the horizontal masses which give strength to the shape of the building.

**Symmetry and Balance:** Balance in most parts of the Maxxi museum is achieved properly without the occurrence of symmetrical parts. So the building could be categorized under asymmetrical balance. Meanwhile, playing with gravity makes the building disturb the overall balance of masses by making a deep cantilever on one side of the project.

**Relationships of a plan to section / elevation:** A proportional relationship exists between the horizontal masses with some inclination to the sides appearing in comparing both plan and section as represented by bold lines in the illustration.

**Geometry:** The design is based, first, on the geometry of the surrounding urban context. The two grid-directions that conflux at the site form part of the project-site. The resulting 51-degree bend is facilitated by curves. The second basis for the design is found in the imposition of a formalism as string as it is rigorous. The formalism includes a series of bending, branching, intersecting, and bundled parallel lines in addition to the exterior continuities in the relevant urban context. The geometrical form of the MAXXI Museum of XXI Century Arts consists of a string of concrete tunnels that intertwine on three levels, and have steel ribs and glass lids on the second and

third floors. Parabolic surfaces, including Euclidean, are used mainly for design purposes in this project.

**Repetitive to unique** by repeating a number of different scaled and rotated concrete tunnels which flow alongside the site and result in a unique mass cantilever on a side of the building.

In regard to all above comments, even upon completion, the museum still maintains its theoretical dimension in that it is a testament to the feasibility of the architectural manifesto propounded by Parametricism. The design of the MAXXXI is about more than simply building a museum. The complexity characteristic of its volumes, different intersections in the levels, variations, and the curving walls all come together to offer visitors a unique experience that they may come into via a variety of entrances and passages. The different spaces within the museum combine to form a series of galleries lit by an impressive light-filtering roof system. The bifurcation, flow, and confluence of the architectural elements account for the existing structures that were integrated into the museum and relate to the various directions of the urban context. The project therefore, is internally constituted as field as opposed to as an object externally, thus representing the immersive, porous field condition of the MAXXI in its entirety.



**MAXXI:  
MUSEUM OF XXI CENTURY ARTS**

ROME, ITALY  
SIZE: 30,000 M<sup>2</sup>  
YEAR: 1998-2009

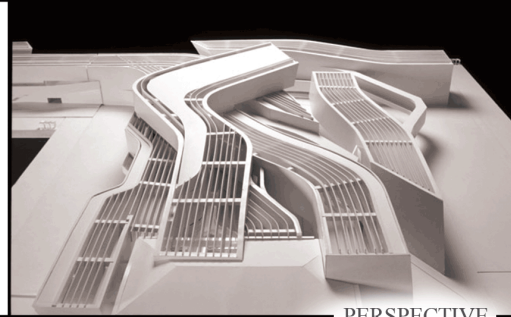

PERSPECTIVE

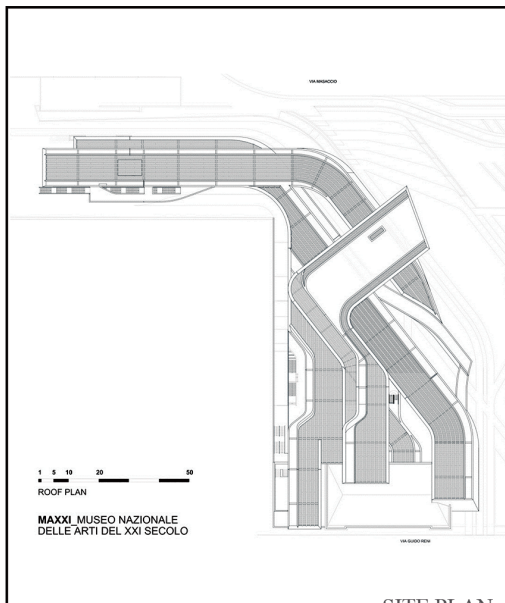

SITE PLAN

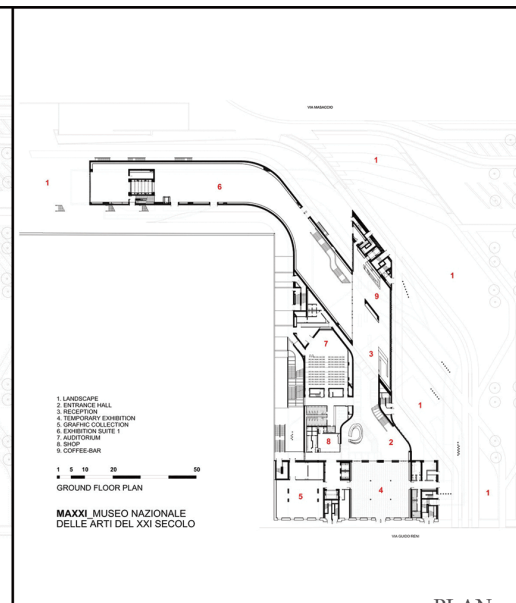

PLAN

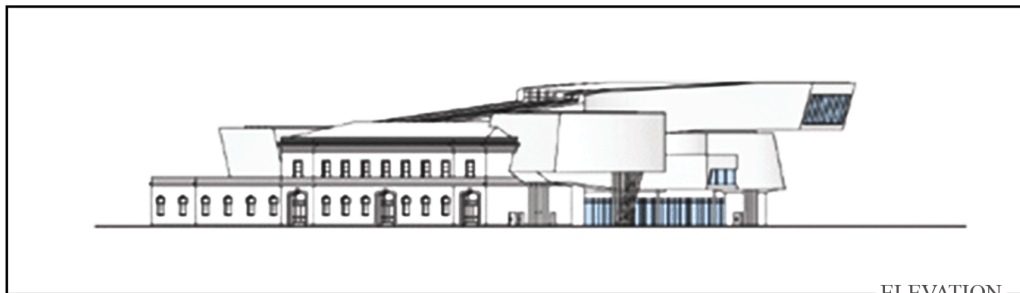

ELEVATION

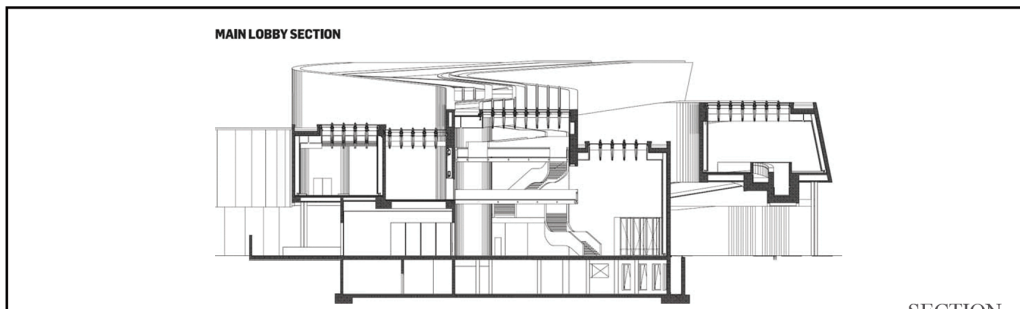

SECTION





**MAXXI:  
MUSEUM OF XXI CENTURY ARTS**



— MASSING —

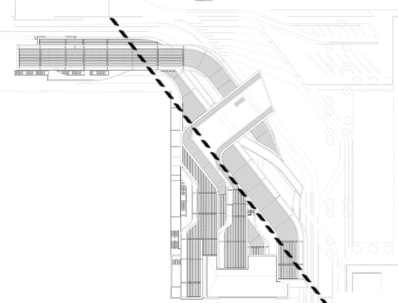

— SYMMETRY & BALANCE —

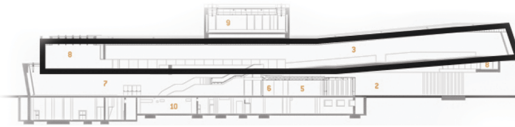
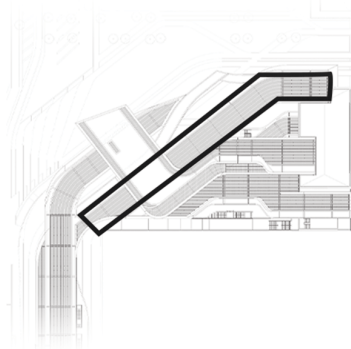

— PLAN - SECTION/ELEVATION RELATIONSHIP —



— GEOMETRY —

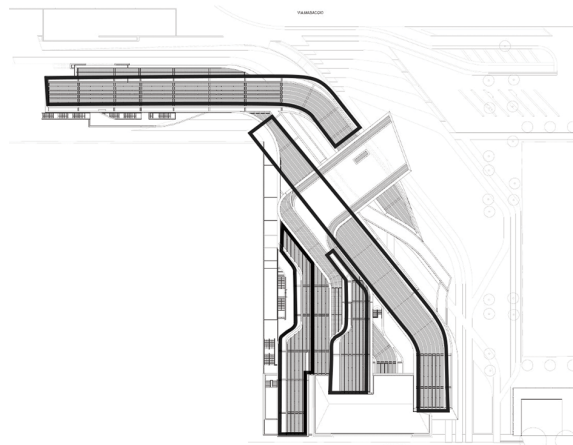

— REPETITIVE TO UNIQUE —

### **3.3.7 Vitra Fire Station, Weilam Rhein, Germany, 1993**

Zaha Hadid's first built project was the Vitra Fire Station. Originally used as a fire station, it has since been repurposed as showroom for Vitra's permanent chair collection following a redrawing of district fire-lines. The fire station was designed for a similarly-named factory in Weilam Rhein, Germany in 1990-1993, one of Hadid's first projects.

#### **3.3.7.1 Design Techniques in Vitra Fire Station**

**Abstraction and fragmentation:** It is known that when a collision occurs between two things, the damage and devastation will affect one or both thereby causing a deformation in their general appearance. That is what Hadid tries to illustrate in the notion of Vitra Fire station (1990). The exploded plan is complemented by a section that similarly departs from the rectilinear norm. The doors in the building jump due to the sloping walls. The floor also appears to be sloping due to the gentle rise of the longest sill. Splays give false perspective just as the parapets and roof terrace converge in the direction of a supposed explosion. The project was initially designed with the aim of avoiding it getting lost amongst the other ships that make up the factory. Identity and rhythm were also given to the complex's main street by the elements (Figure 55).

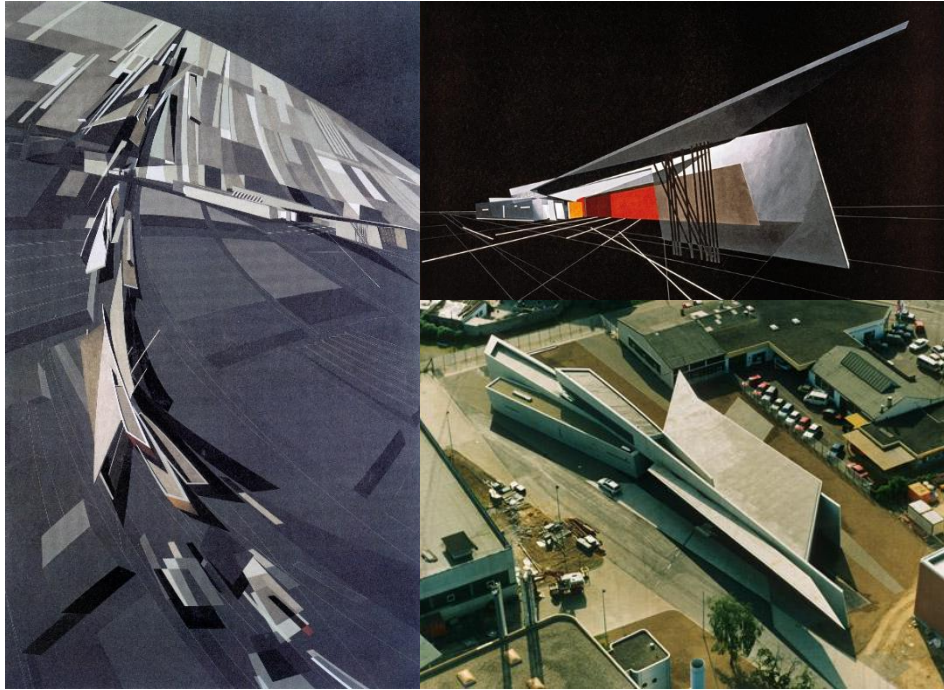

Figure 55: Vitra fire station: the idea of abstraction and fragmentation through collision. Source: Zaha 2009

**Layering:** This project emphasized by elongating the problem to a narrow, lengthy building. The building's form is comprised of a series of overlapping, layered walls. A number of different elements then inhabit the resulting interstitial area. Light is permitted into the building and views are created by the fracture or folding of the walls which follows the particular programmatic elements within (Figure 56).

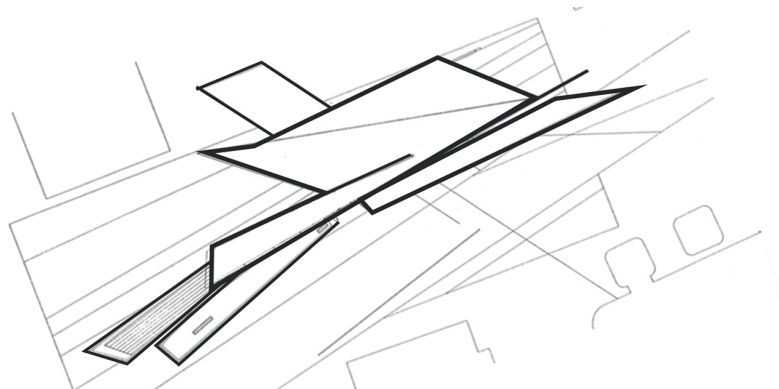

Figure 56: illustration of Vitra fire station from the top view Source: author

**Play of light:** In the Vitra fire station, embedded in the floor and ceiling are continuous slots of fluorescent strips that provide lighting. These slots are often placed in such a way that they illuminate a wall, thus transforming it to a glowing plane as shown in (Figure 57).



Figure 57: Night view of Vitra fire station  
Source: <https://www.architectural-review.com>

**Reflecting Project's Form in the Interior:** Visual simplification is noticeable in both the exterior and interior of the Vitra fire station. This noticeable simplification is present in every one of the building's aspects, from the interior lighting treatment up to the frameless glazing. The light that manages to infiltrate the building is relatively straight lines (Figure 58).



Figure 58: the strong relationship between the exterior and interior of Vitra fire station. Source: <https://deavita.com/>

### **3.3.7.2 Form Pattern in Vitra Fire Station**

The fire station is composed of planes of concrete that tilt, bend, a break depending on the dynamic conceptual energies connecting the architecture and landscape. The concrete planes and shards create a narrow horizontal profile as they slide past each other. While one plane is projected out of the garage bay, the intersection of others intensifies feelings of instability. Stuck in a state of restlessness, the planes have a certain non-transparent quality that limits external visibility, except at locations here the walls separate from the building. Hadid's work relates to the theoretical language of Deconstructivism that she used her paintings to develop as a conceptual intermediary for form and spatial relationships. The form notion is resulting from the collision between two main organizing geometries in the site: the street and factory complex. The Vitra fire station is categorized under the suprematist style.

### **3.3.7.3 Formative Ideas in Vitra Fire Station**

**Massing:** from the analysis of the Vitra Fire station, the massing issue is represented by building using mixture of rectangular planes made from concrete that tilt, bend, and breaks as specified by the abstract forces that connect architecture and landscape. There are few openings in the front and back views except for the entrance openings in the horizontal masses, which give strength to the shape of the building.

**Symmetry and Balance:** A clear absence of symmetrical shapes with a strong balance in each part and overall the station occurs. To enhance the entrance, a huge elongated cantilever with sharp angles, which distorts the balance issue, is used to show the buildings reaction for emergence cases. Thus, the building can be categorized under the asymmetrical balance status.

**Relationships of a plan to section / elevation:** An equal relationship between the semi-sloped rectangular masses occurs with some inclination to the sides appearing in comparing both plan and section as illustrated by the bold line.

**Geometry:** The form notion is resulting from a collision between the two main organizing geometries in the site: the street and factory complex. The geometrical shapes used in the Vitra fire station could be simplified in a series of rectangles and triangles intersecting each other in showing the effects of the deconstructivist style of the building, which has Euclidean geometry specifications.

**Repetitive to unique:** no single shape used in the Vitra fire station completely matches any of the other shapes, meanwhile most of the shapes represent simple geometric shapes repeated with different proportions and angle inclinations.

In regard to all above comments, the building is representative of alertness and an ability to spontaneously rise to action as it resembles frozen movement. Hadid's earliest attempt at materializing her conceptual drawings in the form of functional spaces can be seen in the intersecting planes that delineate the street that cuts through the complex.



### VITRA FIRE STATION

WEIL AM RHEIN, GERMANY  
SIZE: 852 M<sup>2</sup>  
YEAR: 1990-1993



PERSPECTIVE

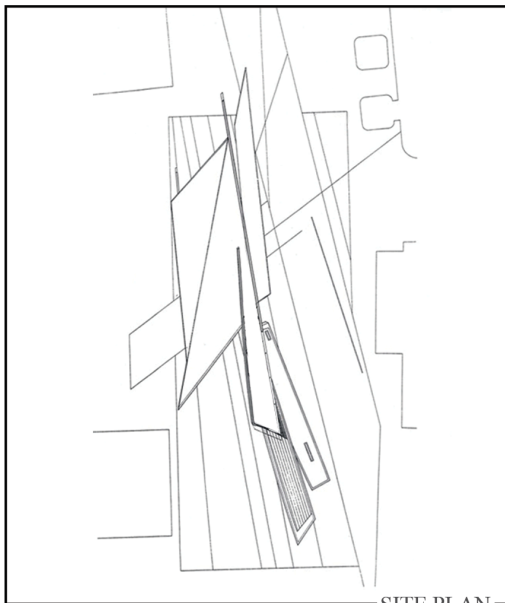

SITE PLAN

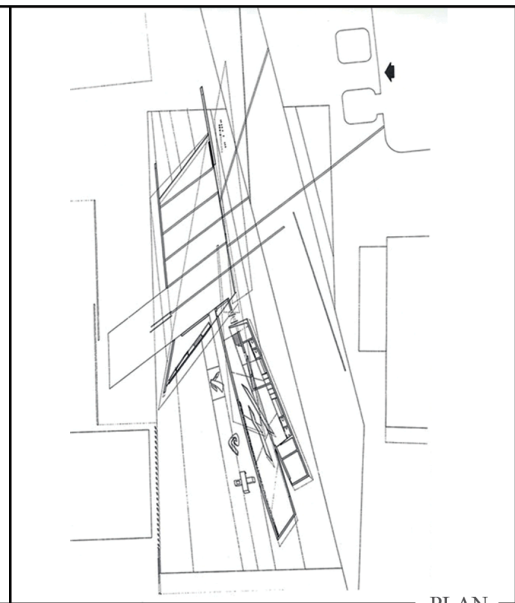

PLAN

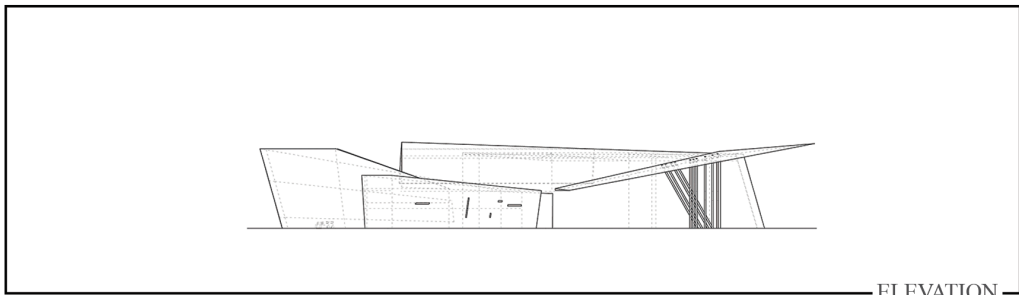

ELEVATION

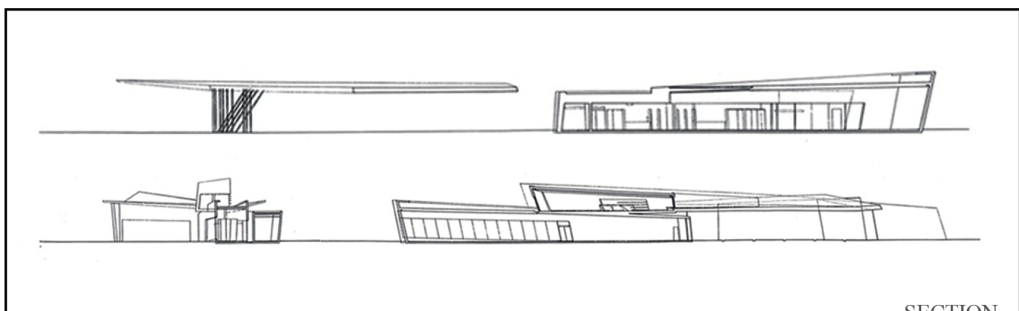

SECTION



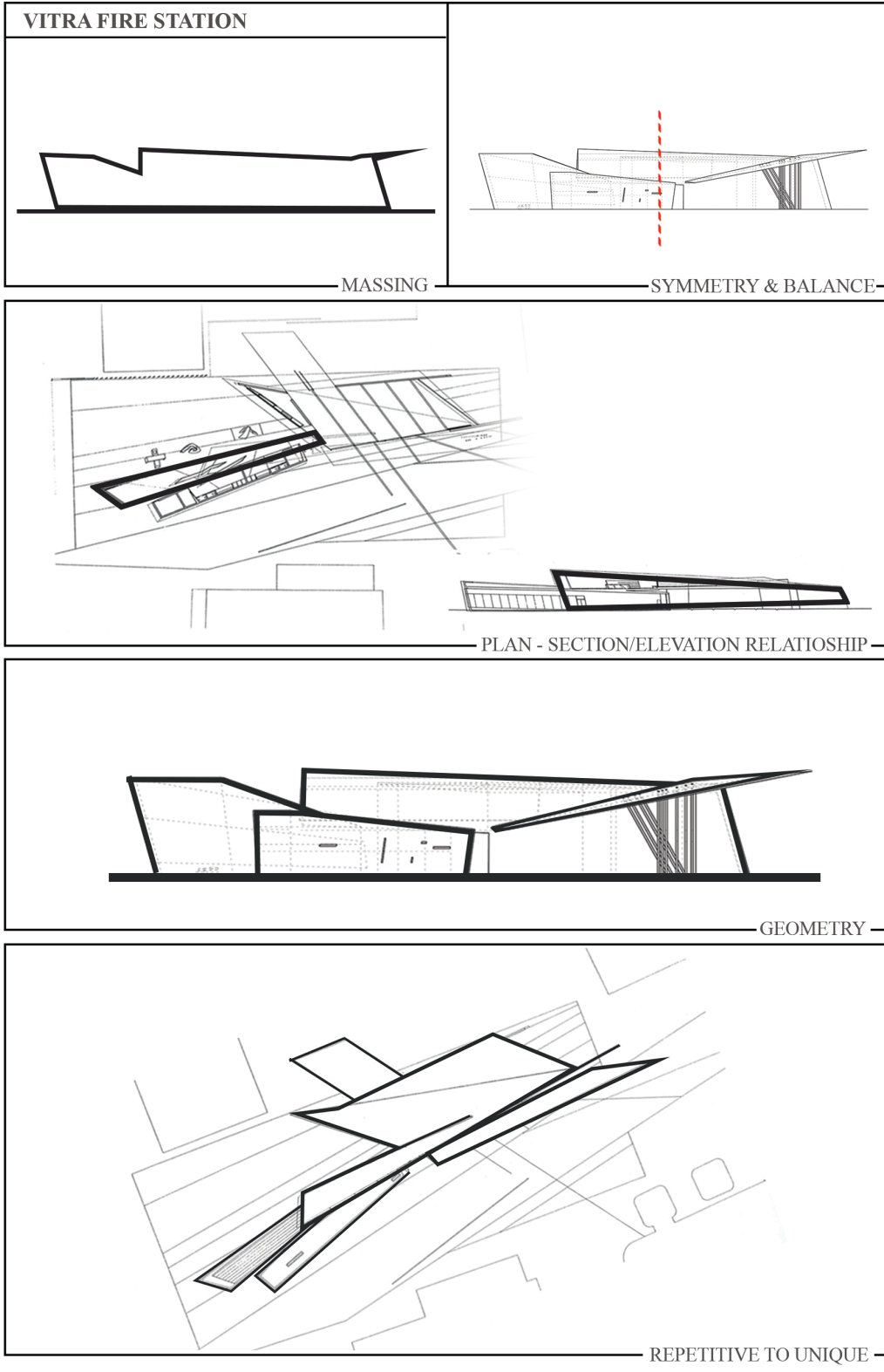



## Chapter 4

### FINDINGS AND DISCUSSION

This study is conducted in order to find answers to three questions posed by many professionals who appreciate Hadid's design; that is, what are the outstanding aspects of Zaha Hadid's buildings iconicity? How could Zaha Hadid produce such iconic architecture? Getting the answers to these questions demands a comprehensive understanding of the various aspects of Hadid's architectural form that are represented in the objectives of this study; they are formative ideas, form patterns, form techniques, and the iconicity features. In the following lines, key findings are discussed and represented by means of certain sets of drawings.

**Techniques of Design in Zaha Hadid Architecture:** Hadid is famous for pushing the boundaries of design, space, and architectural conventions. She generates her own radical design rules that are the result of a mixture of rationalism and her wealth of experience in design. As an ardent student of architecture, nature, art, and efficient surroundings, she investigates the sources of their aesthetic qualities and the factors that make them attractive and uses them in her projects. This eagerness in searching helps Hadid obtain some primary skills she has diligently developed into her own techniques.

The design techniques developed by Hadid herself are identified, as are the various sources from which she drew her inspiration. The individual techniques each have

various applications in different projects. It is important to recollect that using such techniques could result in producing architecture similar to Hadid's. The techniques are: abstraction and fragmentation, defying gravity, seamlessness and fluidity, landscaping the project, layering, and play of light. As illustrated in the table 4, each individual building embodied some of Zaha Hadid's numerable design techniques; meanwhile, the abstraction and fragmentation technique was widely used in the analyzed cases in which it had been developed by Zaha Hadid and used in her own way, followed by the seamlessness and fluidity technique, which enjoyed second most common use. The use of a variety of techniques in a single project enhanced the quality of her buildings.

**Patterns of Form in Zaha Hadid Architecture:** It is well known how Hadid's projects are characterized by variety and differentiation. She has conducted a large number of projects, each of which has its own special form and unique philosophical concept. However, over the course of this study, it has been noticed that there have been incidences of word repetition in interviews and articles written about Hadid and also some features in the exterior form. According to the literature survey, Hadid uses five main patterns of form (discussed in chapter two) which are: Suprematist pattern, Topography Pattern, Fluid Pattern, Organic Pattern, and Parametric pattern.

From the analysis of Zaha Hadid's seven projects in terms of form pattern, it is noticed that most cases involved the use of the Suprematist pattern effect – Vitra Fire Station, Maxxi Museum, Innovation Tower, and Library and Learning center totally represent the Suprematist pattern. Besides her most recent works – the Galaxy SoHo and Dongdaemun Design Plaza, the parametric pattern is mostly used. Additionally, the topography pattern was used for the Heydar Aliyev Museum, which is the most iconic

Project by Zaha Hadid. In some cases, there is the existence of more than one pattern being used and can thus be termed mixed form. One such example is the occurrence of both Fluid and Parametric pattern in the Dongdaemun Design Plaza.

**Formative Ideas in Zaha Hadid Architecture:** Through the analysis of seven buildings by Zaha Hadid in terms of different issues concerning formal design, several issues have been found to inform her formative design ideas, which are mentioned below:

### **1) Massing in Zaha Hadid's Architecture:**

According to the analysis of Zaha's buildings as shown in the table below, different massing techniques were used for generating the form. As shown in the illustrations of both the Heydar Aliyev Museum and Dongdaemun Design Plaza in the table 6, Zaha used the ground plane as a tool to generate the overall mass by playing with the geographical aspects of the site and changing the masses to integrate them with the topography of the site, which gives a great sense of affiliation of the masses to the ground in the elevation. In the Library and Learning Center, and Innovation Tower Jockey Club projects, the masses stand as polygonal inclined blocks with different degrees that represent the defying gravity technique with the intense use of vertical and horizontal fins around the entire building that enhance the quality of the masses. In both the Maxxi Museum Of 21<sup>st</sup> Century Arts and Vitra Fire Station, the masses are located horizontally. In the Maxxi Museum, the masses lie parallel to each other then intersect in different levels of the building while in the Vitra Fire Station they are a series of intersected rectilinear shapes form the mass of the building, which totally represent the abstraction and fragmentation technique, which is exceedingly noticeable in Zaha's architecture. In the Galaxy SoHo Project, the masses are composed of several

continuous, flowing volumes that are linked using stretched bridges; they are a series of Complex forms passed through the distortion technique (Table 6).

## **2) Symmetry and balance in Zaha Hadid Architecture:**

As one of the formative design issues, the symmetry and balance of the seven selected projects by Zaha Hadid have been analyzed and presented in table 7. The symmetry principle is rarely used by Hadid in her projects, while the balance is still in existence. Based on the site plans and elevations of the seven case studies, a general equilibrium exists in the configuration through the unified forms. This is highlighted in the illustrations below through bolded dot lines. The formation of the projects is asymmetrical; however, they show the effect of total rest and stability. This formative issue is applied in most designs regardless of chosen patterns. In studying the architectural form of Hadid, it is observed that she ignores using some principles that used to be essential in generating typical architecture. This is the underlying cause for classifying her as a deconstructivist architect. She breaks down the main principles of conceiving usual buildings with symmetry, idea of the motionless, and stable ground.

## **3) Relationship between plan and section/elevations:**

A proportional relationship of plan and section or elevations can be observed in the Heydar Aliyev Museum, Dongdaemun Design Plaza, and Galaxy SoHo in which the configurative line in both plan and section of the cases is similarly found. Meanwhile, the Library and learning Center, Innovation Tower, and Maxxi Museum are all categorized under an 'Analogue Relationship' in which the upper half outline of the plan in the illustrations is approximately similar to the configuration line of the section with a small difference in between them. Besides, an equal relationship occurs in

between the plan and section of the Vitra Fire Station due to the large percentage of similarity between them (Table8).

#### **4) Geometry in Zaha Hadid Architecture:**

Zaha Hadid uses fascinated geometry in her architecture. Her geometry goes beyond the simple use of geometrical shapes as she attempts to use more complex geometrical shapes including quadric surfaces. In the Heydar Aliyev Museum, Dongdaemun Design Plaza, and Galaxy SoHo, Zaha masterly mixed Hyperbolic and Elliptic geometrical shapes to come out with a unique form,. In the rest, suprematist formed cases, for which Zaha Hadid designed a wide range of Euclidean geometry, mixing with sharp angled geometries are used. In some of the cases, such Innovation Tower the sharp-angled intersections were smoothen under the technique of seamlessness and fluidity, which is one of the most important techniques used in Zaha Hadid's Architecture. To conclude, Hadid masterly used different geometric factors such as hyperbolic geometry and elliptic geometry in her work and this is one of the reasons why her works is differentiated from others. Consequently, it is easy to build a symbolic analogy between Hadid's bulks, Euclidean, and non-Euclidean geometry (Table 9).

#### **5) Repetitive to unique in Zaha Hadid Architecture:**

A simple repetition, Iconicity is the common issue in the seven cases by Zaha Hadid that have been analyzed. In both the Heydar Aliyev Cultural Center and Dongdaemun Design Plaza, the unique style of the building comes from its formal design by curves and reflecting the topography of the site. Repeating a different sized and shaped forms in both of the projects which give an impressive overall form as illustrated in the table 10. Besides, in some cases, the distinctive repetition came from the elevation of the

buildings with different sizes; this kind occurred in both the Library & Learning Center and the Innovation Tower. In Galaxy SoHo, there was the repetition of four elliptic shaped masses within the inner courtyards in different sizes and dimensions in the site plan; however, the repetition of the layers in each elliptic mass gave the project an outstanding and iconic form. In the Maxxi Museum the iconicity comes from repeating a number of different scaled and rotated concrete tunnels which flow alongside the site and result in a remarkable mass cantilever in the side of the building. Finally, in the Vitra Fire Station, every single shape used doesn't match the other shapes totally; meanwhile most of the shapes represent simple geometric shapes repeated with different proportions and angle inclination (Table 10).

**In regard to all above findings, it might be concluded that,** the iconicity of Hadid's projects can be attributed to one simple reason: contradiction. There is a paradox inherent to the techniques used to create rational, yet innovative, architecture. Hadid uses her personal techniques to create unprecedented pieces of architecture. These techniques are a cross between logic and liberation; harmony and strangeness; also irrational and rational. The techniques used to liberate form from existing constraints are abstraction and fragmentation; layering; defying gravity; and play of light. Conversely, landscaping, fluidity, and seamlessness help bring logic back to the form and cause it to be friendly, real, and harmonic. Ignoring certain form principles and using others is also another factor in generating interesting forms e.g. ignoring symmetry and considering balance and asymmetry.

The first objective of the research is answering the question of what are the outstanding aspects of Zaha Hadid's building's iconicity. The outstanding aspects behind Zaha Hadid's building iconicity are the result of pushing the boundaries of space and design

through a variety of design techniques that she uses in her designs, which are: abstraction and fragmentation, defying gravity, seamlessness and fluidity, landscaping the project, play of light, and layering.

Hadid's techniques are rooted in various cultures and domain; this has given her work its peculiar international appeal. Abstraction for example, was adapted from her study of mathematics while Chinese architecture, Russian suprematism, and the work of Mies van der Rohe provide inspiration for her defiance of gravity. Additionally, seamlessness and fluidity were gotten from her observance of organic things in nature and Arabic calligraphy while Chinese landscaping and art inspired her landscaping, layering, and play of light. Evidently, Hadid's special architectural style draws on a variety of sources.

The second objective, similarly, is to uncover just how Zaha Hadid could produce such an iconic architecture? It is well known how Hadid's projects are characterized by variety and differentiation. She has completed a large number of works, each work with its own special form and its unique philosophical concept. However, through conducting this study, it has been noticed the different patterns of form that she uses in her designs and developed it continuously as discussed in section 2.2 produces such an iconic architecture. Hadid produced that iconic architecture by using five main patterns of form, the patterns are: Suprematist pattern, Topography Pattern, Fluid Pattern, Organic Pattern, and parametric pattern. In regards to Form patterns in Zaha Hadid's architecture, the projects under the first pattern, suprematism, are characterized by the use of analogous fundamental geometric forms and defying gravity, while the topographic pattern includes all projects whose form notions are inspired by the natural land formations, such as dunes and contours lines. The organic

pattern comprises projects where the configuration is a simulation of natural creatures like sea animals. Projects' forms generated by the facilities available through parametric design system are categorized under parametric pattern. Finally, the fluid pattern, not under any of the mentioned patterns, is generated by the fluid dynamism of her hand sketching characterized by the seamlessness and outflowing features of water and Arabic calligraphy.

The third objective is answering: How are Hadid's buildings influential in the field of Architecture? What makes Hadid's works influential in architectural field is her desire to catch up with the latest technological advances and everything new qualified her to be a global architect and this could be comprehended through observing the sequence emergence of her patterns. She was a pioneer architect in Deconstructivism in the 1980s and lately Zaha Hadid Architect office has launched the latest architectural program; parametric design system. Parametricism is suggested to be the epochal architectural style of the 21st century. Moreover, what make the works of Hadid iconic is her use of contradiction in form principles as well as her chosen techniques. The techniques used are a mix of rational and irrational; liberation and logic; and strangeness and harmony, while some of form principles have been used and the others were ignored. The origins of these techniques were adapted from different domains, cultures, and countries that radically developed to produce new kind of architecture. This inferred the familiarity of Hadid architecture at the international level.

The sequence steps for Hadid's design infer that she deals with the architectural work as a piece of art which pleases the viewers and simultaneously meets the requirements of successful architecture; the architecture which not only offers a shelter but also stimulates human's mind to meditate, react and motivate him to invent. Her view of



architecture from this perspective qualified her to establish a new kind of building style accompanied by strong theoretical concepts. Her sequential successes in competitions have influenced her colleagues in a way makes them taking the same path of design and this results in the current giant developments in this sector. She even has reformulated the meaning of architecture through her works. In other words, Hadid gives architecture its true colorful picture and has left her mark in this sector.

Hadid masterly uses different geometric factors such as hyperbolic geometry and elliptic geometry on her works and this is one of the reasons why her works are differentiated from others. Thus, a symbolic analogy between Hadid's bulks, Euclidean, and non-Euclidean geometry can be easily be built. Ignoring certain form principles and using others is also another factor in generating interesting forms, such as ignoring symmetry and considering balance and asymmetry.

Table 4: Design approaches of Zaha Hadid in term of patterns of form and design techniques





CASES	PROJECT NAME	YEAR	FUNCTIONS	PERSPECTIVE	PATERN OF FORM	DESIGN TECHNIQUE	ICONICITY
CASE 01	<b>Heydar Aliyev Museum</b>	2010 2012	Includes: <ul style="list-style-type: none"> <li>• Conferences</li> <li>• 3 Auditoriums</li> <li>• library</li> <li>• Museum</li> </ul>		Topographic Form	<ul style="list-style-type: none"> <li>• Landscaping the Surrounding Context</li> <li>• Seamlessness and Fluidity</li> <li>• Reflecting the Form of the Project in the Space's Interior Design</li> <li>• Abstraction and fragmentation</li> </ul>	The seamless exclusive style of the building comes from its formal design by curves and reflecting the site topography, also using this variety of innovative design techniques. The iconic structure gained through tasking with assembling more than 9 acres of multi-directional curved steel segments. The roof was used to form the building's walls, ceilings, and stairs resulting it being one of the world's most complex structures ever.
CASE 02	<b>Dongdaemun Design Plaza</b>	2007 2013	<ul style="list-style-type: none"> <li>• exhibition halls</li> <li>• conference hall</li> <li>• design museum</li> <li>• design labs</li> <li>• media center,</li> <li>• seminar rooms,</li> <li>• designers lounge</li> </ul>		Parametric and Fluid	<ul style="list-style-type: none"> <li>• Seamlessness and Fluidity</li> <li>• Landscaping the Surroundings</li> <li>• Abstraction and fragmentation</li> <li>• Play of light</li> </ul>	The Plaza's design was based, to a large extent, on groundbreaking BIM modeling and parametric design. Construction of the DDP's exterior was particularly problematic as the cladding system required the assembly of 40,000 differently sized panels with different curvatures. The park is truly iconic as it seamlessly spreads onto the rooftop of the plaza. All of these make DDP an iconic building.
CASE 03	<b>Library and learning center</b>	2008 2012	Includes: <ul style="list-style-type: none"> <li>• Main Library</li> <li>• Auditorium</li> <li>• Study Rooms</li> </ul>		Suprematist	<ul style="list-style-type: none"> <li>• Defying gravity</li> <li>• Abstraction and fragmentation</li> <li>• Play of light</li> <li>• Reflecting the Form of the Project in the Space's Interior Design</li> </ul>	It is possible to see the irregular, cantilevered roof of the building afar, as well as the protruding glass-fronted monitor. The building's linear exterior lines separate as they move inward, becoming curvilinear and fluid. The iconic form created by Zaha Hadid for new LLC for Vienna's University of Economics and Business is a conclusive testimony to the function of a modern library.
CASE 04	<b>Galaxy SoHo</b>	2009 2012	Includes: <ul style="list-style-type: none"> <li>• Retail</li> <li>• Offices</li> <li>• entertainment complex</li> </ul>		Parametric	<ul style="list-style-type: none"> <li>• Play of light</li> <li>• Layering</li> <li>• Seamlessness and fluidity</li> <li>• Reflecting the Form of the Project in the Space's Interior Design</li> </ul>	One of the conceptual design aims of the project is to internally replicate a Chinese courtyard with 21 century design by Integrating Parametric technique in the design. The other draws inspiration from the terraced rice fields of ancient China. Meanwhile, it is a corner-less 360-degree architectural world.
CASE 05	<b>Innovation Tower; Jockey Club</b>	2007 2014	<ul style="list-style-type: none"> <li>• design studios</li> <li>• labs &amp; workshops, exhibition areas</li> <li>• multi-functional classrooms</li> <li>• lecture theatre</li> <li>• communal lounge</li> </ul>		Suprematist	<ul style="list-style-type: none"> <li>• Seamlessness and fluidity</li> <li>• Layering</li> <li>• Using Distorted Addition Technique accompanied with Strong Justified Notion</li> <li>• Reflecting Project's Form in the Interior Design of Space</li> </ul>	With a unique building geometry also an exceptional three dimensional metal cladding selection. The integration of BIM into the design and construction of this three dimensionally irregular-shaped building resolved the evolving geometry of Jockey Club Innovation Tower. The design brazenly tries to provide a vision of future possibilities while reflecting the institution's history.
Case 06	<b>Maxxi Museum of XXI century Arts</b>	1998 2009	<ul style="list-style-type: none"> <li>• Museum</li> <li>• Auditorium</li> <li>• 5 Exhibitions Suits</li> </ul>		Suprematist	<ul style="list-style-type: none"> <li>• Fragmentation and Abstraction</li> <li>• Ideas of Gravity and Ground</li> <li>• Layering</li> <li>• Seamlessness and Fluidity</li> <li>• Play of light</li> <li>• Reflecting the Form of the Project in the Space's Interior Design</li> </ul>	Forming the Project According to the Current Urban Grids Deep cantilever without support that cannot be constructed easily Overlapping and interweaving.
Case 07	<b>Vitra Fire Station</b>	1990 1993	Includes: <ul style="list-style-type: none"> <li>• Fire Station</li> <li>• Bicycle shed</li> <li>• Boundary walls for factory's land</li> </ul>		Suprematist	<ul style="list-style-type: none"> <li>• Abstraction and fragmentation</li> <li>• Layering</li> <li>• Play of light</li> <li>• Reflecting the Form of the Project in the Space's Interior Design</li> </ul>	The building in its entirety signifies frozen movement, it expresses the tension of constant alertness and ability to spring to action upon a moment's notice.

Table 5: Formative Design Ideas of Zaha Hadid Architecture

CASES	PROJECT NAME- YEAR	PERSPECTIVE	FORMATIVE IDEAS			
			MASSING	BALANCE AND SYMMETRY	RELATIONSHIP BETWEEN PLAN AND SECTION	GEOMETRY
CASE 01	<b>Heydar Aliyev Museum, 2012</b>		Zaha attempt to play with one mass which is the ground an applying the topography pattern principles so as to come out with such flowing mass.	Asymmetrical balance	Analogue relationship	Quadric surfaces including: • Hyperbolic • Elliptic
CASE 02	<b>Dongdaemun Design Plaza, 2013</b>		Massing is a representative of techniques in parametric design, which helps to gain a complex design by a simple masses.	Asymmetrical balance	Proportional relationship	Quadric surfaces including: • Hyperbolic • Elliptic
CASE 03	<b>Library and learning center, 2012</b>		The building stands as a polygonal block with is inclined masses and columns with 35 degree from the center of the university. Complex rectangular forms passed through fragmentation technique.	Asymmetrical balance	Analogue relationship	Quadric surfaces including: Euclidean
CASE 04	<b>Galaxy SoHo, 2012</b>		It is composed of a number of uninterrupted flowing volumes linked together by stretched bridges. Complex forms passed through distortion technique.	Asymmetrical balance	Proportional relationship	Quadric surfaces including: • Hyperbolic • Elliptic
CASE 05	<b>Innovation Tower; Jockey Club, 2014</b>		It's a represent of two merged polygonal which inclined to toward outside and rises by 73 meters above the earth level and a series of external vertical and horizontal fins around the entire building enhancing the quality of the masses.	Asymmetrical balance	Analogue relationship	Quadric surfaces including: • Euclidean • Semi elliptic
Case 06	<b>Maxxi Museum of XXI century Arts, 2009</b>		Maxxi Museum massing issue can be denoted through dominance of parallel horizontal masses stretched through the site and turns into L shape with smooth corners.	Asymmetrical balance	Analogue relationship	Quadric surfaces including: • Euclidean • Semi elliptic
Case 07	<b>Vitra Fire Station, 1993</b>		A mixture of rectangular concrete planes that tilt, bend, and breaks as specified by the abstract forces linking architecture and landscape.	Asymmetrical balance	Analogue relationship	Sharp angle triangular shapes with polygonal shapes



Table 6: Massing of the selected buildings







CASES	PROJECT NAME	MASSING ILLUSTRATIONS	ANALYSIS
CASE 01	Heydar Aliyev Museum, 2012		Zaha attempt to play with one mass which is the ground an applying the topography pattern principles so as to come out with such flowing mass.
CASE 02	Dongdaemun Design Plaza, 2013		Massing is a representative of techniques in parametric design, which helps to gain a complex design by a simple masses. Also the clear use of topography pattern techniques in it.
CASE 03	Library and learning center, 2012		The building stands as a polygonal block with is inclined masses and columns with 35 degree from the center of the university. Complex rectangular forms passed through fragmentation technique.
CASE 04	Galaxy SoHo, 2012		It's a composition of several distinct uninterrupted volumes joined by stretched bridges, Complex forms passed through distortion technique.
CASE 05	Innovation Tower; Jockey Club, 2014		It's a represent of two merged polygonal which inclined to toward outside and rises by 73 meters above the earth level and a series of external vertical and horizontal fins around the entire building enhancing the quality of the masses.
Case 06	Maxxi Museum of XXI century Arts, 2009		Maxxi Museum massing issue can be denoted through dominance of parallel horizontal masses stretched through the site and turns into L shape with smooth corners.
Case 07	Vitra Fire Station, 1993		A mixture of rectangular concrete planes that tilt, bend, and break as specified by the dynamic conceptual forces that connect architecture and landscape.

Table 7: Symmetry & Balance in the selected buildings

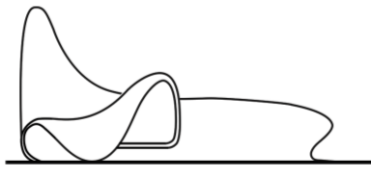

CASES	PROJECT NAME	SYMMETRY AND BALANCE ILLUSTRATIONS	ANALYSIS
CASE 01	Heydar Aliyev Museum, 2012		Asymmetrical balance
CASE 02	Dongdaemun Design Plaza, 2013		Asymmetrical balance
CASE 03	Library and learning center, 2012		Asymmetrical balance
CASE 04	Galaxy SoHo, 2012		Asymmetrical balance
CASE 05	Innovation Tower; Jockey Club, 2014		Asymmetrical balance
Case 06	Maxxi Museum of XXI century Arts, 2009		Asymmetrical balance
Case 07	Vitra Fire Station, 1993		Asymmetrical balance

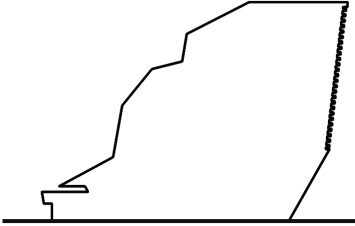
Table 8: Relationships of a plan to section in the selected buildings

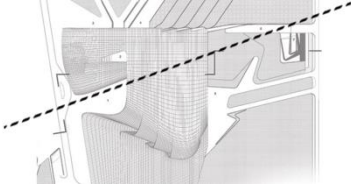

CASES	PROJECT NAME	RELATIONSHIPS OF A PLAN TO SECTION ILLUSTRATIONS	ANALYSIS
CASE 01	Heydar Aliyev Museum, 2012		Proportional relationship
CASE 02	Dongdaemun Design Plaza, 2013		Proportional relationship
CASE 03	Library and learning center, 2012		Analogue relationship
CASE 04	Galaxy SoHo, 2012		Proportional relationship
CASE 05	Innovation Tower; Jockey Club, 2014		Analogue relationship
Case 06	Maxxi Museum of XXI century Arts, 2009		Analogue relationship
Case 07	Vitra Fire Station, 1993		Equal relationship

Table 9: Geometry in the selected buildings

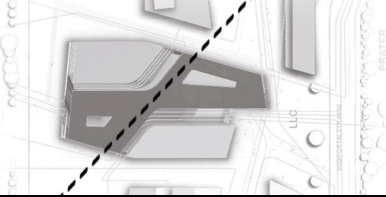
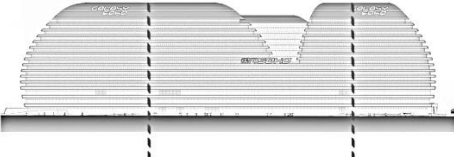
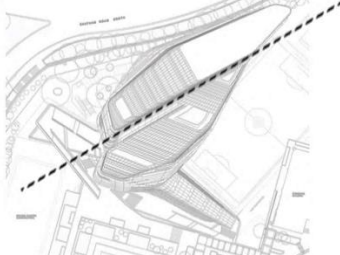
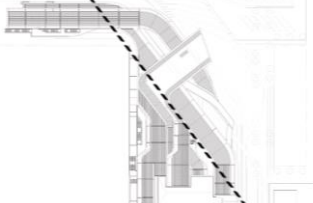
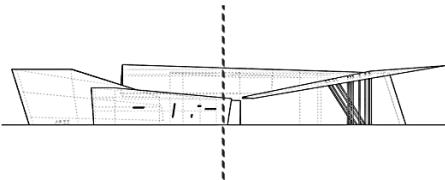

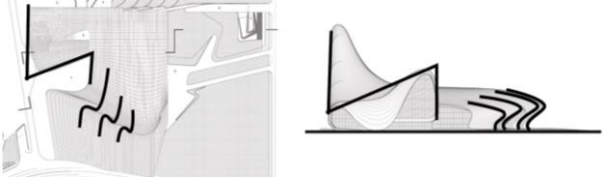
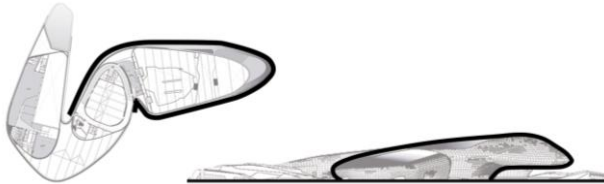
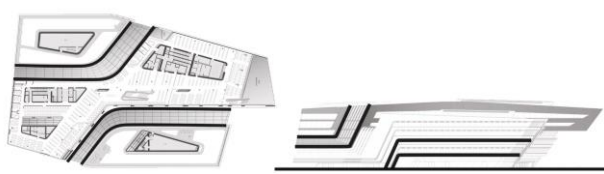
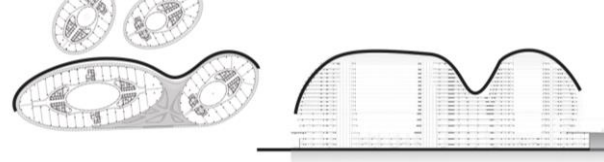
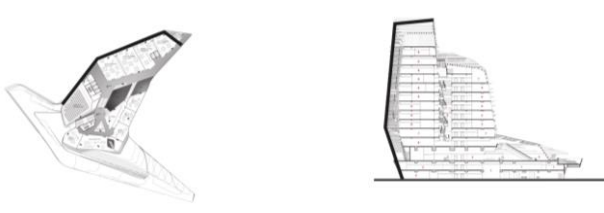

CASES	PROJECT NAME	GEOMETRY ILLUSTRATIONS	ANALYSIS
CASE 01	Heydar Aliyev Museum, 2012		Quadric surfaces including: <ul style="list-style-type: none"> <li>• Hyperbolic</li> <li>• Elliptic</li> </ul>
CASE 02	Dongdaemun Design Plaza, 2013		Quadric surfaces including: <ul style="list-style-type: none"> <li>• Hyperbolic</li> <li>• Elliptic</li> </ul>
CASE 03	Library and learning center, 2012		Quadric surfaces including: <ul style="list-style-type: none"> <li>• Euclidean</li> </ul>
CASE 04	Galaxy SoHo, 2012		Quadric surfaces including: <ul style="list-style-type: none"> <li>• Hyperbolic</li> <li>• Elliptic</li> </ul>
CASE 05	Innovation Tower; Jockey Club, 2014		Quadric surfaces including: <ul style="list-style-type: none"> <li>• Euclidean</li> <li>• Semi elliptic</li> </ul>
Case 06	Maxxi Museum of XXI century Arts, 2009		Quadric surfaces including: <ul style="list-style-type: none"> <li>• Euclidean</li> <li>• Semi elliptic</li> </ul>
Case 07	Vitra Fire Station, 1993		Sharp angle triangular shapes with polygonal shapes

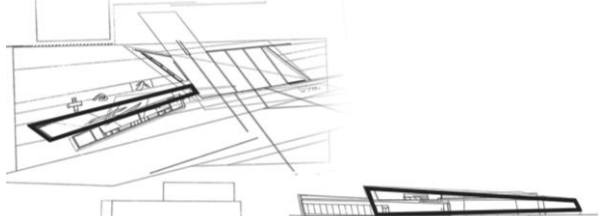
Table 10: Repetitive to unique in the selected buildings



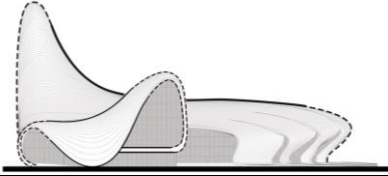

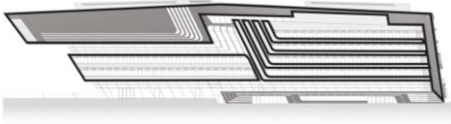
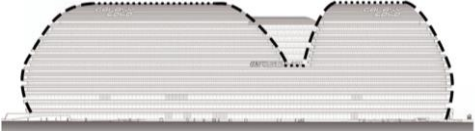
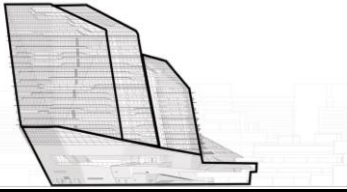

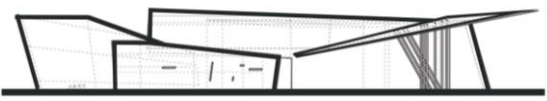



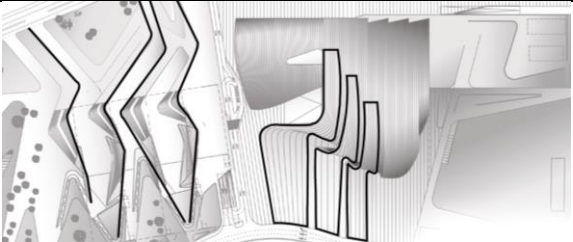
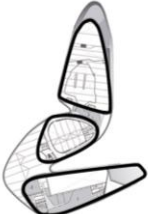
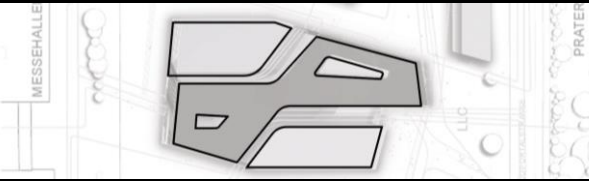
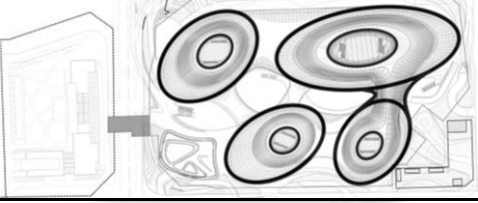
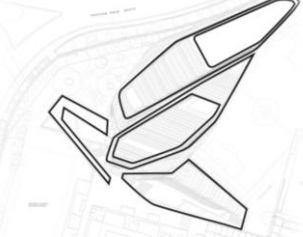
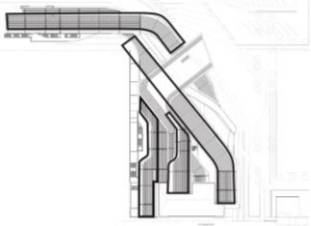
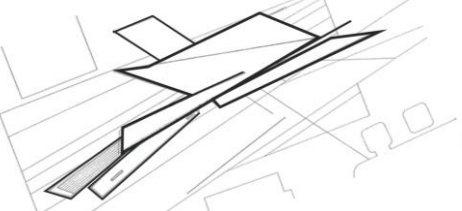
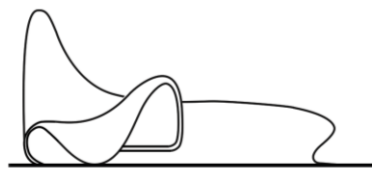
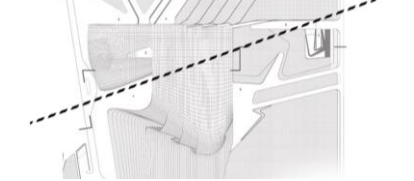
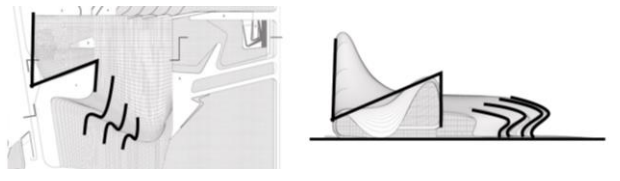
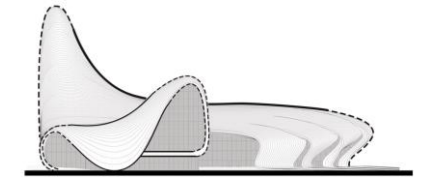

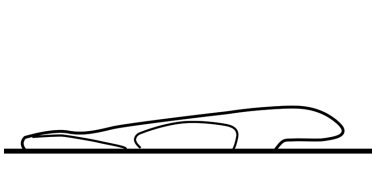
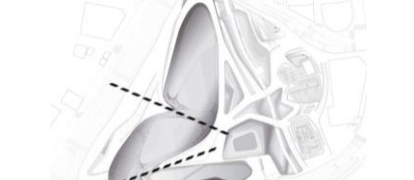

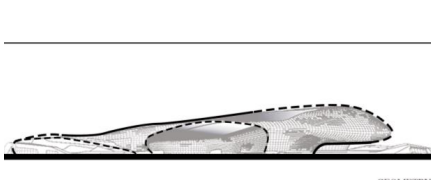
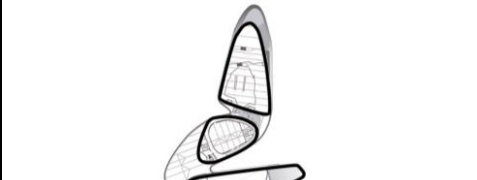
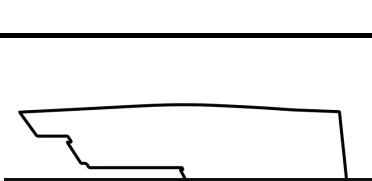
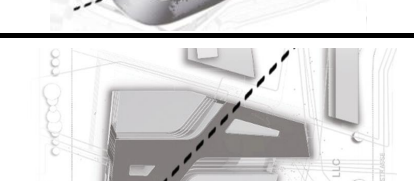
CASES	PROJECT NAME	REPETITIVE TO UNIQUE ILLUSTRATIONS
CASE 01	Heydar Aliyev Museum, 2012	
CASE 02	Dongdaemun Design Plaza, 2013	
CASE 03	Library and learning center, 2012	
CASE 04	Galaxy SoHo, 2012	
CASE 05	Innovation Tower; Jockey Club, 2014	
Case 06	Maxxi Museum of XXI century Arts, 2009	
Case 07	Vitra Fire Station, 1993	

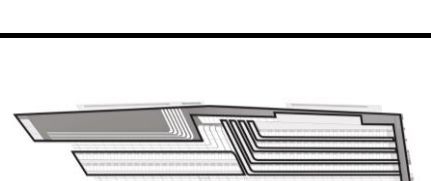
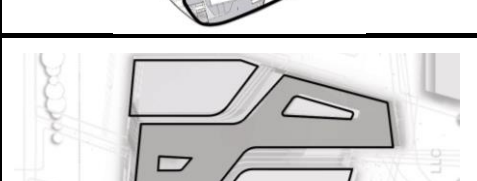
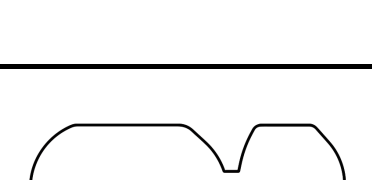
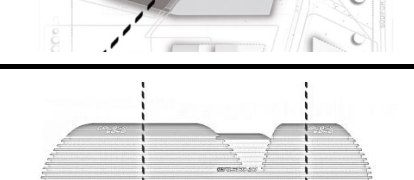
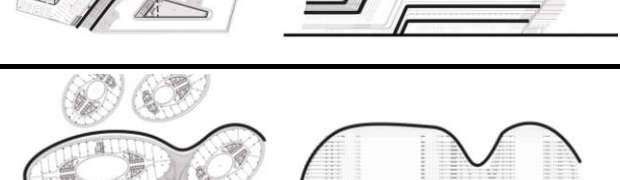

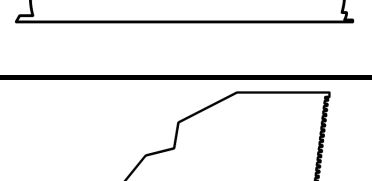
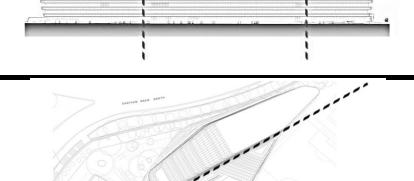
Table 11: Illustration of Formative Design Ideas in the selected buildings of Zaha Hadid

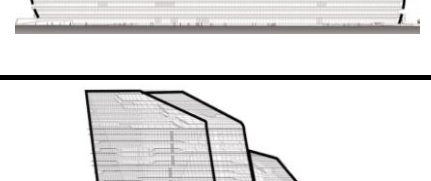
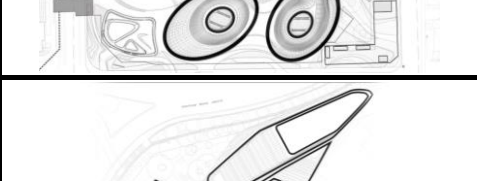
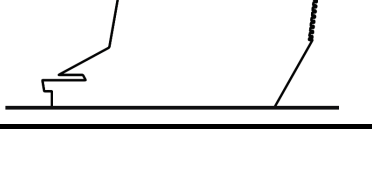
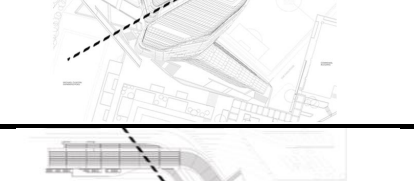
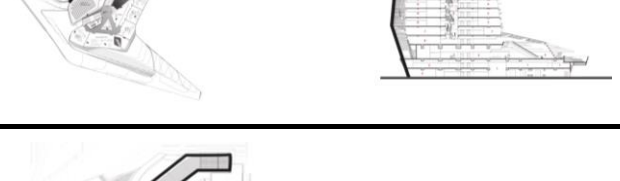
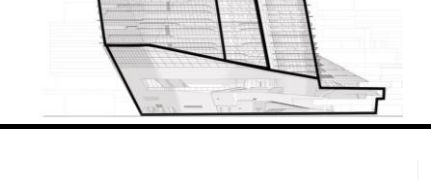
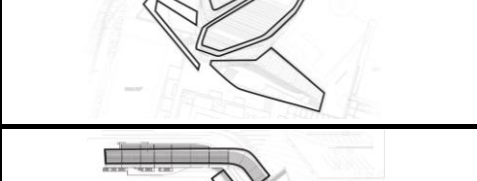
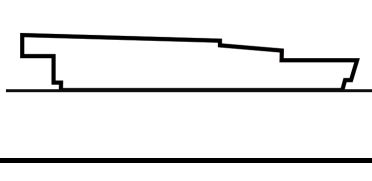
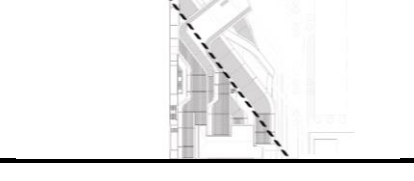
PROJECT NAME-YEAR	FORMATIVE IDEAS				
	MASSING	BALANCE AND SYMMETRY	RELATIONSHIP BETWEEN PLAN AND SECTION	GEOMETRY	REPETITIVE TO UNIQUE
CASE 01 Heydar Aliyev Museum, 2012					
CASE 02 Dongdaemun Design Plaza, 2013					
CASE 03 Library and learning center, 2012					
CASE 04 Galaxy SoHo, 2012					
CASE 05 Innovation Tower; Jockey Club, 2014					
Case 06 Maxxi Museum of XXI century Arts, 2009					
Case 07 Vitra Fire Station, 1993					

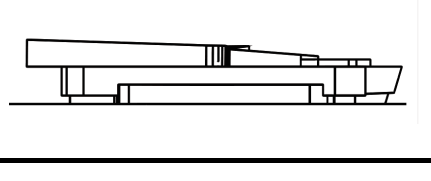
## Chapter 5

### CONCLUSION

Associated with the ongoing technological developments in all areas of life, architecture is starting to take a turn from the usual; it is the architecture of form and high welfare. The architecture of today is produced by an eager generation of innovation and creation; Zaha Hadid is at the forefront of them. Hadid has many impressive projects distributed in the most advanced countries in the world. She had a high sensation for art and beauty in nature; she even conceived architecture as an art, which meets the requirements of good building that satisfy physical and moral conditions. Her use of contradictory techniques led to the emergence of a globally-acceptable people-friendly form of architecture. Hadid's willingness to keep up with everything new made her always in the lead thus inspiring a younger generation of architects and designers. Despite of the outstanding architecture of Zaha Hadid many architects and theorists have criticized her for her abnormal architectural designs and confusing structures, her architecture was criticized as being aggressive, intractable and bitter.

Furthermore, the variety of ambivalence and contradiction in the form patterns is key to producing iconic architecture. It is hardly an exaggeration to say that Hadid has incited a shift in the way the world perceived architecture and has even caused a number of seasoned architects to indulge in self-reflection to determine if they are reflecting current trends in their work. In Zaha Hadid Architecture, the projects under

the first pattern, suprematism, are characterized by analogous fundamental geometric forms and defying gravity; topographic pattern includes all projects that their form notions are inspired from the natural land formation such as dunes and contours lines; organic pattern is used for projects whose configuration is a simulation of natural creatures such as sea animals; projects 'forms generated by the facilities available through parametric design system are categorized under parametric pattern; and finally, fluid pattern is the one generated by the fluid dynamism of her hand sketches characterized by the seamlessness and outflowing features of water and Arabic calligraphy.

The outstanding aspects behind Zaha Hadid's building iconicity include pushing the boundaries of space and design through a variety of design techniques that she uses in her designs. From the analysis of Zaha's buildings, contradiction is the underlying reason of Hadid works 'iconicity. Paradox in the used techniques has created integration in conceiving and achieving the innovative and rational architecture. Hadid has her self-developed techniques to produce unprecedented works. These techniques are a mixture between liberation and logic; rational and irrational; and strangeness and harmony. The liberating techniques for form are fragmentation and abstraction; defying gravity; layering; and play of light, while the others that return form to logic and qualified it to be real, friendly, and harmonic project are landscaping the project; seamlessness; and fluidity. Ignoring form principles and using others are also another factor of generating interested forms such as ignoring symmetry and considering balance and asymmetry.

What makes Hadid's works influential in architectural field is her desire to catch up with the latest technological advances and everything new qualified her to be a global

architect and this could be comprehended through observing the sequent emergence of her patterns. She was a pioneer architect in Deconstructivism in the 1980s and lately Zaha Hadid Architect office has launched the latest architectural program; parametric design system. Parametricism is suggested to be the epochal architectural style of the 21st century.

The projects of Zaha Hadid left a footprint in development of architecture in term of forms, spaces and abnormality in structures, as her projects are the bright issue in architectural discourses nowadays and become an icon for the cities which they built in. Despite of the architectural shift due to the variety of technological development Zaha Hadid Architecture will stay highlighted in architectural field because her Architecture was a turning point in this field. So it is not fashion that might be changeable, neglected or disappeared in future of architectural design.

This study recommends further future studies on Zaha Hadid Architecture about her role in development and regeneration the discourse of Architecture. Such as Zaha Hadid Architecture sustainability, the contribution of Hadid in changing the overall formation of perceiving the architectural space, Hadid sketches and their effective role to formative the final form.

The study expects that student of architecture inspire from Zaha Hadid Architecture by utilizing the analysis done in this research. Finally always “Keep pace with the on-going changes in the world” as recommended by Hadid.

## REFERENCES

- A.D. King (2008). “*Architecture, Globalization and Identity*”, Architecture and Identity, Peter Herrle and Erik Wegerhoff (Eds.) LIT Verlag Münster, Berlin, pp.221-230.
- Abdullah, A. (2013). *Zaha Hadid form making strategies for design*. Master Thesis Universiti Teknologi, Malaysia.
- Abdullah, A., Said, I., & Ossen, D. (2013). *Zaha Hadid’s techniques of architectural form-making*. Open Journal of Architectural Design, 1(1), 1-9.
- Aiello, T. (2005). Head-First Through the Hole in the Zero: Malevich’s Suprematism, Khlebnikov’s Futurism, and the Development of a Deconstructive Aesthetic, 1908-1919. *Emajartjournal*, p.3.1-1.16.
- Barber, L. (2008, March 9th). Zaha Hadid. *Guardian magazine*, Retrieved Oct 18, 2012, from <http://www.guardian.co.uk/lifeandstyle/2008/mar/09/women.architecture>
- Bedell, G. (2003, Feb 2nd). Space is her place. *Guardian magazine*, Retrieved May 14, 2012 from <http://www.guardian.co.uk/artanddesign/2003/feb/02/architecture.artsfeatures>

Belogolovsky, V. (2008, Aug 31st). Zaha Hadid. *Russian Architectural News Agency*  
Retrieved 22 Sep, 2012, from  
[http://archi.ru/agency/eng/news\\_current.html?nid=8497](http://archi.ru/agency/eng/news_current.html?nid=8497)

Bowl, E. J. (1976). *Russian Art of the Avant-Garde: Theory and Criticism*, From  
Cubism and Futurism to Suprematism. London: Thames and Hudson, 1988,  
pp.19-133.

C. Jencks (2007). "The Iconic Buildings is Here to Stay", Hunch: Rethinking  
Representation, Penelope Dean (Ed.), Episode Publishers, Rotterdam, p: 48-61.

Cattermole, P. (Ed.). (2008). *Architectural Excellence: 500 iconic buildings*. Firefly  
Books Limited, US & Canada.

Ching, D. F. (1996) *Architecture \_Form, Space, Order*. (2nd. Ed.). Canada: John  
Wiley & Sons.

Clark, R. H., & Pause, M. (2005). *Precedents in architecture: analytic diagrams,  
formative ideas, and partis*. John Wiley & Sons.

Colegio de Arquitectos del Per. (2012, Nov 6). Arq. ZAHA HADID - Entrevista.  
YouTube, Retrieved Dec 20, 2012, from  
<http://www.youtube.com/watch?v=hT1Opt3qVCQ>

Cruz, CA, (2012) '*Wright's Organic Architecture: From 'Form Follows Function' to 'Form and Function are One'*', Wolkenkuckucksheim - Cloud-Cuckoo-Land - Vozdushnyi zamok, vol. 32, pp. 27-36.

Designboom (2007, Jan15th). Designboom Interview: Zaha Hadid. *Designboom Magazine*. Retrieved Jan 2ed, 2012, from <http://www.designboom.com/eng/interview/hadid.html>

Designmuseum, (2007, Nov 25th). Zaha Hadid. *Designmuseum Organization*. Retrieved Aug 23rd, 2012, from <http://designmuseum.org/design/zahahadid>

Dezeen (2010, July 12). Zaha Hadid and Suprematism at Galerie Gmurznska Zurich. *Dezeen Magazine*. Retrieved Feb 23, 2012, from <http://www.dezeen.com/2010/07/12/zaha-hadid-and-suprematism-at-galerie>

Dezeen Magazine, (2011, Feb 7th). Concept villas for golf and spa resort, Dubrovnik, by Zaha Hadid Architects. *Dezeen Magazine*. Retrieved Feb 4ed, 2012, from <http://www.dezeen.com/2011/02/07/concept-villas-for-golf-and-spa-resortdubrovnik-by-zaha-hadid-architects>

Didero, C. M. (2012, 27 Jul). Zaha Hadid and Suprematism. *Domus magazine*. Retrieved Dec 9th, 2012, from <http://www.domusweb.it/en/reviews/2012/07/27/zaha-hadid-and-suprematism.html>

Forrest, S. (2008, Jan 23th). Zaha Hadid. *The New York Times*. Retrieved Sep 20th, 2012, from

[http://topics.nytimes.com/top/reference/timestopics/people/h/zaha\\_hadid/index.html?8qa](http://topics.nytimes.com/top/reference/timestopics/people/h/zaha_hadid/index.html?8qa)

Giovannini, J. (1996). Portrait: Zaha Hadid, architecture's new diva makes an international scene. *Architectural Digest* 53, 1, 26-35

Glancey, J. (2006, Oct 9th). I Don't Do Nice. *The Guardian magazine*. Retrieved April 4th, 2012 from

<http://www.guardian.co.uk/artanddesign/2006/oct/09/architecture.communities>

Gopnik, B. (2011, Sep 21st). Architecture's Rising Diva. *News Week Magazine*. Retrieved May 1<sup>st</sup>, 2012 from

<http://www.thedailybeast.com/newsweek/2011/09/18/design-diva-hits-ahigh-z-zaha-hadid.html>

Greenway, O. (2011, July 8th). *I believe in hard work, as it gives you confidence*. *Travel Time Magazine*, London.

Hadid, M. Z. (2009). *Zaha Hadid-Complete Works*. New York, USA: Rizzoli International Publication.

Hadid, Z (2005). Zaha Hadid. *The MIT Press*. 37. pp. 130-135.



Hadid, Z. (1998). *Zaha Hadid the Complete Building and Projects*. London, United Kingdom: Thames & Hudson.

Hadid, Z. (1991). *Recent work*. In J. Noever (Ed.), *Architecture in transition: between deconstruction and new modernism* (pp. 47-61). Munich: Prestel.

Hadid, Z. (1992). *Another beginning*. In J. Noever (Ed.), *The end of architecture? Documents and manifestos* (pp. 25-33). Munich: Prestel.

Hadid, Z. (2002) *Opere e progetti*, Rome, 2002. *Zaha Hadid Website*. Retrieved June 29th, 2011, from [www.zaha-hadid.com/exhibitions/opere-e-progetti-exhibition](http://www.zaha-hadid.com/exhibitions/opere-e-progetti-exhibition)

Hadid, Z. (2006). *Zaha Hadid*. New York, USA: Guggenheim Museum Publication.

Hadid, Z. (2009). *The Complete Zaha Hadid*. London, United Kingdom: Thames & Hudson.

Hadid, Z. (2011, Dec 30th). Like a breath of fresh air. *China Daily USA Newspaper*. Retrieved Jan 1st, 2013. From [http://usa.chinadaily.com.cn/weekly/201112/30/content\\_14354279.htm](http://usa.chinadaily.com.cn/weekly/201112/30/content_14354279.htm)

Hadid, Z. and Aaron, B. (2009). *Zaha Hadid The Complete*. New York, USA: Rizzoli International Publications. 211

Hattenstone, S. (2003, Feb 3rd). Master builder. *Guardian Magazine*. Retrieved June 18th, 2012 from

<https://www.theguardian.com/artanddesign/2003/feb/03/architecture.artsfeature>

S

Hattenstone, S. (2010, Oct 9th). Zaha Hadid: 'I'm happy to be on the outside'. *Guardian magazine*. Retrieve May 10th, 2012 from <http://www.guardian.co.uk/artanddesign/2010/oct/09/zaha-hadid>

Hollingsbee, T. (2009, Jan). Interview with Lars Teichmann. *UK ADAPTA*. Retrieve Jan 7th, 2013, from <http://www.ukadapta.com/e/architecture/zahahadid.html>

Kauw, W. M. (1998). *Generation of Abstract Geometric Art Based on Exact Aesthetics, Gestalt Theory and Graphic Design Principles*. MFutagawa, Y. (Ed.) (2010). An Email Dialogue, July, 2010 Zaha Hadid. In: Y.

King, W. (2008, April 18). Retrieved November 3, 2010, from *Modern Day Iconic Buildings - What Really Makes Them Iconic?:*  
<http://ezinearticles.com/?Modern-Day-Iconic-Buildings---What-Really-Makes-Them-Iconic?&id=2983327>

Kiziltepe F. (2015) *Zaha Hadid's architecture from, a different perspective*, Anadolu University, Faculty of Architecture and Design.

Koenig, G. (2000). *Iconic LA: stories of LA's most memorable buildings*. Balcony Press.

L. Sklair (2008). “*Iconic Architecture and Capitalist Globalization*”, Architecture and Identity, Peter Herrle and Erik Wegerhoff (Eds.) LIT Verlag Münster, Berlin, pp.207-220.

Leach, N. (2009). *Digital Cities AD: Architectural Design*. International house London: John Wiley & Sons.

McCready, L. (2012, March 25th) Zaha Hadid: Form in Motion. *Vogue Magazine*. Retrieved Jan 7th, 2013 from: <http://search.proquest.com/docview/898680913/fulltext/13A1A365BB65CE0034F290/12?accountid=41678>

McLeod, M. (1989). Architecture and Politics in the Reagan Era: From Postmodernism to Deconstructivism. *The MIT Press*, 8, 22-59.

Meades, J. (2008, Summer). Zaha Hadid: The First Great Female Architect. *Intelligent Life Magazine*. Retrieved April 18<sup>th</sup>, 2012 from <http://moreintelligentlife.com/story/zaha-hadid>

Mertins, D. (2006). The Modernity of Zaha Hadid, Hadid, Z. *Zaha Hadid*. New York, USA: Guggenheim Museum Publication.

Methanoia (2010, Nov 23rd). Zaha Hadid Architects: Rabat Grand Theatre. *Designboom Magazine*. Retrieved Dec 3rd, 2012 from <http://www.designboom.com/architecture/zaha-hadid-architects-rabat-grand-theatre/>

Michaud, J. (2011, July 18<sup>th</sup>). Zaha Hadid: The Lady GAGA of Architecture. *The New Yorker*. Retrieved April 25<sup>th</sup>, 2017 from <http://www.newyorker.com/books/double-take/zaha-hadid-the-lady-gaga-of-architecture>

Moore, R. (2015, September 26). Zaha Hadid: A visionary whose ideas don't always make sense | Rowan Moore. Retrieved July 14, 2017, from <https://www.theguardian.com/artanddesign/2015/sep/27/zaha-hadid-profile->

NewYooxer (2010, June 8<sup>th</sup>). Zaha Hadid @ Maxxi. *NewYooxer*. Retrieved on Jun 4, 2016 from <http://www.thenewyooxer.yoox.com/eng/index.php/post/5351/zahahadidmaxxi>

Pearson, D 2001, *New Organic Architecture, The Breaking Wave*, Gaia Books Limited, London.

Perović M 2005, *Istorija moderne arhitekture, Antologija tekstova*, Knjiga 2/A *Kristalizacija modernizma, veliki majstori*, Draslar Partner, Beograd.

Pfeiffer, BB 2011, *Frank Lloyd Wright on Architecture, Nature, and the Human Spirit*. A Collection of Quotations, Pomegranate Europe Ltd., Warwick.

Platt, H. K. (2012, Sep 12<sup>th</sup>). Zaha Hadid and the Energy of Change. *New York Times*. Retrieved Nov 25<sup>th</sup>, 2012 from <http://www.nytimes.com/2012/09/13/arts/13iht-rarthadid13.html>

Pulse, A. (2011, Oct15<sup>th</sup>). Zaha Hadid Celebrates the Launch of her Third LONDON Project. *Asia Pulse*. Retrieved Oct 25, 2012 from <http://trove.nla.gov.au/work/157769017?versionId=171987245>

Salama, M. A. (2007). Nikos A. Salingaros: A New Vitruvius for 21st-Century Architecture and Urbanism. *International Journal of Architectural Research*. 1(2), p.114-131.

Schumacher, P. (2009). *Parametricism: A new global style for architecture and urban design*. *Architectural Design*, 79(4), 14-23.

Straeten, D.V. (1997) .The Uncanny and the Architecture of Deconstruction, *Magazine of the Visual Narrative*. Retrieved Oct 10<sup>th</sup>, 2012 from <http://www.imageandnarrative.be/inarchive/uncanny/bartvanderstraeten.htm>

V. Ryan, 2010, <http://www.technologystudent.com/prddes1/prddex1.html>

Yvonne, C. (2009, July 16). *What makes a building iconic?* Retrieved 11 January, 2010, from "A look at local 'iconic' Properties" Malaysian Business: <http://www.scribd.com/doc/43727127/What-Makes-a-Building-Iconic-2>

Yuan, C. and Yi, Z. (2012). To Discuss the Application of Parametric Technology in Architectural Design. *Applied Mechanics and Materials*. 174-177, pp.1734-1738.

Zaha Hadid, April 22, 2009, Pritzker Acceptance Speech, 2004, at:  
[http://www.pritzkerprize.com/sites/default/files/file\\_fields/field\\_files\\_inline/2004\\_Acceptance\\_Speech.pdf](http://www.pritzkerprize.com/sites/default/files/file_fields/field_files_inline/2004_Acceptance_Speech.pdf)