

**An Analysis on Spatial Organization of Living Room
and Kitchen Spaces in Contemporary Domestic
Architecture of Northern Cyprus**

Ladan Mohammadzadehafshar

Submitted to the
Institute of Graduate Studies and Research
In partial fulfillment of the requirements for the degree of

Master of Science
in
Interior Architecture

Eastern Mediterranean University
December 2015
Gazimağusa, North Cyprus

Approval of the Institute of Graduate Studies and Research

Prof. Dr. Cem Tanova
Acting Director

I certify that this thesis satisfies the requirements as a thesis for the degree of Master of Science in Interior Architecture.

Prof. Dr. Uğur Dağlı
Chair, Department of Interior
Architecture

I certify that I have read this thesis and that in my opinion it is fully adequate in scope and quality as a thesis for the degree of Master of Science in Interior Architecture.

Assoc. Prof. Dr. Asu Tozan
Supervisor

Examining Committee

1. Assoc. Prof. Dr. Nil Paşaoğluları Şahin

2. Assoc. Prof. Dr. Asu Tozan

3. Asst. Prof. Dr. Kamil Güley

ABSTRACT

House is the section of an inside environment measured as a private place for humankind. Some other places such as workplaces, merchants, factories and also school are the section of an interior setting but there is a big difference, they are distributed to others. These types of places are arranged based on the needs of groups, clients and customers; they are definitely not private areas of the manger or customers. However, house environment is only the personal place between other inner surface environments which can be used as being an individual place. It is just the place where man structured their lifestyles based on the users' needs, society, culture and climate.

Especially living room and kitchens are the most important to trace functional complexities of daily living and dining, cultural ways of realization of functions, separation and integration according to privacy levels, adaptability for rituals and gathering, representation of personal preferences, and religious symbols.

In domestic architecture since the early periods, it appeared that buildings had been started to change in several developing countries. According to these kind of alterations and within the new kind of houses, people cannot follow their own traditional habits and also their particular cultures' lifestyle. This thesis aimed to re-define the characteristics of "living spaces" of vernacular architecture and investigate the new tendencies in Northern Cyprus in the case of Yeniboğaziçi village. Purposes of the study were to emphasize the importance of the inherited values of living spaces in contemporary architecture. And define continuities and discontinuities of characteristics of living spaces in recent housing developments in Yeniboğaziçi. Data

for this research was based on the literature review and fieldwork consisting a case study on a series of selected houses at Yeniboğaziçi village. This study focused on house interiors only in living room and kitchen spaces. Moreover, major discussions in this study were based on user needs', lifestyle, culture, and technology.

This thesis formed into five parts. The first chapter is an introduction that is included of the basic information. In this part the significance of this study can clearly be understood due to the problems and also aim and the limitations of the study. Chapter two gives explanation of domestic architecture, spatial organization and architectural elements of living room and kitchen spaces in a house according to the effect of the culture and lifestyle on them.

The third chapter gives explanation of spatial organization and architectural elements of living room and kitchen interiors of houses from Ottoman period to Turkish Republic period in Northern Cyprus in case of Yeniboğaziçi village.

According to chapter three, in the fourth chapter, spatial organization of living room and kitchen spaces in houses from Yeniboğaziçi in Famagust in Northern Cyprus analyzed in three groups of houses. Group one is about five contemporary houses. Second group included five single new houses. And third group is about five apartments. Studies examined living room and kitchen spaces used observations, sketches and photograph of houses.

The characteristics and spatial organization in interior design of houses are changing continuously. Developed the new materials, other than, new technologies have an

effect on the form of the buildings, especially houses and their organizations, the elements and decorations.

Increase in dynamics of Famagusta and expansion of urban texture until Yeniboğaziçi has transformed the vernacular settlement character and domestic architecture tradition dramatically. The analysis show that architectural values of vernacular architecture has abandoned. But new developments starting with “Citta Slow” membership has already motivated rediscovering process of the vernacular values.

Keywords: Domestic architecture, Space organization, Living room and Kitchen, Northern Cyprus, Yeniboğaziçi village.

ÖZ

Konut, iç mekânın bir parçası ve aynı zamanda insanların mahrem mekânları olarak değerlendirilir. Ofis, ticari mekân, fabrika ve okul gibi diğer binalarda da iç mekân ihtiyaçları söz konusu olsa da, kapsam konuttan farklıdır. Çünkü bu mekânlar kamuya açıktır. Bu tip mekânlar farklı kullanıcı gruplarının ve de işverenlerin ihtiyaçlarına göre düzenlenmektedir. Bu nedenle sözü edilen mekânlar kesinlikle müşterinin ya da işverenin mahrem mekânı olarak düzenlenmemektedir. Ancak, konut ortamı diğer iç mekânlar arasında kullanıcının kişisel mekânı olarak düzenlenen tek/yegâne ortamdır. Konut, insanların yaşam biçimlerine bağlı olarak; kullanıcıların ihtiyaçları, toplum, kültür ve iklim etkisiyle oluşturulan çok katmanlı bir yapıya sahiptir.

Özellikle oturma odası ve mutfaklar, günlük/gündelik yaşam ve yemek yemenin fonksiyonel çeşitlenmelerin barındırması yanında, işlevlerin kültüre göre gerçekleştirilmesinin izlerini, hedeflenen mahremiyet düzeylerine göre bir aradalık ve ayrılmayı öngören çözümleri, ritüeller ve toplanma ihtiyaçlarına göre adapte olabilirdiği, aynı zamanda kullanıcılarının kişisel tercihlerini ve dini sembollerini de barındıran mekânlardır.

Gelişmekte olan ülkelerde erken dönemlerden başlayarak konut mimarisinde değişimler yaşanmaya başlamıştır. Konut mimarisinde gerçekleşen yenilikler, değişiklikler kullanıcılarının geleneksel alışkanlıklarını ve kültürlerinin öngördüğü yaşam şeklini sürdürmesine imkân vermemektedir. Bu tez; Kuzey Kıbrıs'ta Yeniboğaziçi köyünde yakın geçmişte inşa edilen konutların 'yaşam mekânlarının' karakteristik özelliklerinin incelemesi neticesinde geleneksel mimari değerlerin

yeniden tanımlanması ve yeni eğilimlerin anlaşılmasını amaçlamıştır. Bu çalışmanın amacı, Yeniboğaziçi köyünde yaşam mimarisinin yüzyıllardan beridir süregelen birikiminin günümüze kadar süreklilik gösterebilen özelliklerini ve rastlanan yeni eğilimleri tanımlamaktır. Buna ek olarak, çağdaş yaşam mekânlarında saptanan özgün –geleneksel- değerlerin anlaşılmasını sağlamaktır. Bu araştırmadaki veriler, literatür taramasına ve Yeniboğaziçi köyünden seçilen bir dizi konutun alan çalışmasına bağlı olarak toplanmıştır. Bu çalışma, konut iç mekânlarında oturma odaları ve mutfak mekânlarına odaklanmıştır. Ancak, bu çalışmanın temel tartışmaları konut oluşumunda etkili olan kullanıcıların ihtiyaçlarına, yaşam tarzına, kültür ve teknolojiye bağlı olarak şekillenmiştir.

Tez beş bölümden oluşmaktadır. Birinci bölüm temel bilgilerin yer aldığı giriş kısmını içermektedir. Bu bölümde, problem tanımı, amaç ve çalışmanın sınırları belirtilmiş ve tez konusunun önemi açıkça anlatılmıştır. İkinci bölümde konut mimarisinin açıklaması, mekânsal organizasyonu ve oturma odası ve de mutfak mekânlarının kültür ve yaşam tarzlarına göre konutlardaki etkileri belirtilmiştir.

Üçüncü bölümde Kuzey Kıbrıs'ta Osmanlı döneminden başlayarak Kuzey Kıbrıs Türk Cumhuriyeti dönemine kadar konut gelişimi ve yaşam mekânları incelenmiştir. Ardından, Yeniboğaziçi köyünde, sözü edilen tarihsel süreç doğrultusunda konutların oturma odaları ve mutfak alanlarının mekânsal organizasyonları ve mimari elemanları açıklanmıştır.

Dördüncü bölümde, Kuzey Kıbrıs Mağusa – Yeniboğaziçi köyünde bulunan konutların oturma odaları ve mutfak alanlarının mekânsal organizasyonları üç konut grubu ile analiz edilmiştir. Birinci grupta beş çağdaş konut; ikinci grupta yeni yapılan

beş müstakil konut ve üçüncü grupta ise beş apartman dairesi seçilmiştir. Seçilen konutların, oturma odası ve mutfak mekânları gözlem tekniği, eskiz çizimi ve fotoğraflama yöntemi ile incelenmiştir.

Konutların mekânsal organizasyonları ve iç mekân tasarımlarının değişmekte olduğu saptanmıştır. Yeni çıkan malzemeler bunun yanı sıra yeni teknolojiler, binaların özellikle konutların formlarını, mekânsal organizasyonlarını, elemanlarını ve dekorasyonlarını etkilemiştir.

Mağusa kentinin dinamik değişimi ve kent sınırlarının Yeniboğaziçi köyüne kadar genişleyen yapısı, köyün geleneksel yerleşim karakterini ve konut mimarisini dramatik bir şekilde etkilemiştir. Yapılan analizler, geleneksel mimari değerlerinin büyük ölçüde kaybolduğunu göstermektedir. Ancak, yavaş kent sloganını benimseyen “Citta Slow” organizasyonuna üyelik ile başlanan yeni gelişmeler geleneksel mimari değerlerin de yeniden keşfedilmesini sağlama yönünde motivasyon ve farkındalığın yeniden oluşmaya başladığını göstermektedir.

Anahtar Kelimeler: Konut Mimarisi, Mekân Organizasyonu, Oturma Odası ve Mutfak, Kuzey Kıbrıs, Yeniboğaziçi Köyü.

To My Family

ACKNOWLEDGEMENT

I would like to express my gratitude to my supervisor Assoc. Prof. Dr. Asu Tozan for her encouragement, helpful advice and guidance. This study is so much depended on her guiding me through the overall research and for her stimulating and relevant criticisms of my entire work.

I also would like to extend my gratitude to Assoc. Prof. Dr. Nil Paşaoğluları Şahin and Assist. Prof. Dr. Kamil Güley, who were supported me through thick and thins of this thesis with their insightful knowledge, thank you for the encouragement and directing me to follow my interests.

The guidance and encouragement of all the members of the Faculty of Architecture at Eastern Mediterranean University played a great role in the preparation of this study.

I would like to express my deep thanks to my sister, Lida Mohammadzadehafshar for her helpful efforts and encouragement throughout the study.

I must record a huge dept of gratitude to my mother and father for their unlimited care and dedication, and also for their emotional and financial support all through my research.

Finally, I owe grateful thanks to all the kind people of Cyprus for providing me help to be able to make research in their houses. Without their compassion this research would not be completed.

TABLE OF CONTENTS

ABSTRACT	iii
ÖZ	vi
ACKNOWLEDGEMENTS	x
TABLE OF CONTENTS	xi
LIST OF TABLES	xiv
LIST OF FIGURES	xvi
1 INTRODUCTION	1
1.1 Background of the Study	1
1.2 Problem Statement	3
1.3 Aims of the Study	4
1.4 Methodology	5
1.5 Limitations	6
2 THEORETICAL ASPECTS OF SPACE	8
2.1 Domestic Architecture	9
2.1.1 Definition of House and Home Terms	13
2.2 Vernacular Architecture	14
2.3 Culture	15
2.4 Spatial Organization and Architectural Elements	17
2.4.1 Plan Layout	17
2.4.2 Space Organization	17
2.4.3 Walls	22
2.4.4 Openings	22
2.4.5 Lighting and Color	24

2.4.6 Furniture and Fixtures	26
2.5 Characteristics of Living Room and Kitchen Spaces	29
3 CHARACTERISTICS OF VERNACULAR AT NORTHERN CYPRUS	34
3.1 Historical Background of Cyprus	34
3.1.1 Ottoman Period (1571-1878)	36
3.1.2 British Period (1878-1960)	43
3.1.3 Republic of Cyprus Period (1960-1963)	44
3.1.4 Turkish Republic of Northern Cyprus (T. R. N. C.) Period (1974- TODAY)	45
3.2 Development of Vernacular Architecture, Culture and Living Environments in Northern Cyprus	46
3.2.1 Yeniboğaziçi as a Village under Famagusta’s Changing Dynamics	49
4 ANALYSIS OF LIVING ROOM AND KITCHEN SPACES AT YENİBOĞAZIÇI VILLAGE	52
4.1 Importance of Living Room and Kitchen Spaces	52
4.2 Method of Analysis	52
4.2.1 Evaluation of Selected Living Room and Kitchen Interiors	53
4.3 Analysis of Living Room and Kitchen Interiors	53
5 CONCLUSION	82
REFERENCES	85
APPENDIX	94
Appendix 1: Additional Visual Data of No: 1.1	95
Appendix 2: Additional Visual Data of No: 1.2	96
Appendix 3: Additional Visual Data of No: 1.3	97
Appendix 4: Additional Visual Data of No: 1.4	98

Appendix 5: Additional Visual Data of No: 1.5	99
Appendix 6: Additional Visual Data of No: 2.1	100
Appendix 7: Additional Visual Data of No: 2.2	101
Appendix 8: Additional Visual Data of No: 2.3	102
Appendix 9: Additional Visual Data of No: 2.4	103
Appendix 10: Additional Visual Data of No: 2.5.....	104
Appendix 11: Additional Visual Data of No: 3.1	105
Appendix 12: Additional Visual Data of No: 3.2	106
Appendix 13: Additional Visual Data of No: 3.3	107
Appendix 14: Additional Visual Data of No: 3.4	108
Appendix 15: Additional Visual Data of No: 3.5	109

LIST OF TABLES

Table 1.1: Organization and the Structure of the Thesis	7
Table 2.1: Organization and Structure of Chapter 2	8
Table 2.2: Summery of the Domestic Architecture	11
Table 4.1: Spatial Organization and Architectural Elements of Living room and Kitchen Spaces, Inventory, No: 1.1	58
Table 4.2: Spatial Organization and Architectural Elements of Living room and Kitchen Spaces, Inventory, No: 1.2	59
Table 4.3: Spatial Organization and Architectural Elements of Living room and Kitchen Spaces, Inventory, No: 1.3	60
Table 4.4: Spatial Organization and Architectural Elements of Living room and Kitchen Spaces, Inventory, No: 1.4	61
Table 4.5: Spatial Organization and Architectural Elements of Living room and Kitchen Spaces, Inventory, No: 1.5	62
Table 4.6: Spatial Organization and Architectural Elements of Living room and Kitchen Spaces, Inventory, No: 2.1	66
Table 4.7: Spatial Organization and Architectural Elements of Living room and Kitchen Spaces, Inventory, No: 2.2	67
Table 4.8: Spatial Organization and Architectural Elements of Living room and Kitchen Spaces, Inventory, No: 2.3	68
Table 4.9: Spatial Organization and Architectural Elements of Living room and Kitchen Spaces, Inventory, No: 2.4	69
Table 4.10: Spatial Organization and Architectural Elements of Living room and Kitchen Spaces, Inventory, No: 2.5	70

Table 4.11: Spatial Organization and Architectural Elements of Living room and Kitchen Spaces, Inventory, No: 3.1	74
Table 4.12: Spatial Organization and Architectural Elements of Living room and Kitchen Spaces, Inventory, No: 3.2	75
Table 4.13: Spatial Organization and Architectural Elements of Living room and Kitchen Spaces, Inventory, No: 3.3	76
Table 4.14: Spatial Organization and Architectural Elements of Living room and Kitchen Spaces, Inventory, No: 3.4	77
Table 4.15: Spatial Organization and Architectural Elements of Living room and Kitchen Spaces, Inventory, No: 3.5	78
Table 4.16: Summery of Spatial Organization and Architectural Elements of Living room and Kitchen Spaces in Yeniboğaziçi Village Houses	79

LIST OF FIGURES

Figure 2.1: erarchy of spaces, private, semi-private, communal spaces	20
Figure 2.2: The Interior and Exterior of spaces	21
Figure 2.3: Walls	22
Figure 2.4: Different Windows	23
Figure 2.5: Different Doors	24
Figure 2.6: Lighting Fixtures	25
Figure 2.7: Different Furniture Organization in Living Spaces	26
Figure 2.8: Fixtures	29
Figure 2.9: Interior Spaces of Various Cultures	30
Figure 3.1: The Location of Cyprus.....	35
Figure 3.2: Arrangements of Rooms in Turkish House	39
Figure 3.3: Organization of the Sofa and Rooms in Turkish Houses	40
Figure 3.4: A Room of the Turkish House	41
Figure 3.5: The Location of the Fathers' Place in Traditional Turkish House	41
Figure 3.6: Sofa room	42
Figure 3.7: Sample of British House	44
Figure 3.8: House from 1960s	45
Figure 3.9: Mass Housing Apartment	46
Figure 3.10: Typical Vernacular House in Agrida (Ağırdağ)	48
Figure 3.11: The Location of Yeniboğaziçi Village	49
Figure 3.12: Yeniboğaziçi Village	50
Figure 3.13: Typical Vernacular House in Yeniboğaziçi Village	51
Figure 4.1: Site Plan of Yeniboğaziçi Village	54

Figure 4.2: Contemporary Houses in Yeniboğaziçi Village	55
Figure 4.3: Single New Houses in Yeniboğaziçi Village	63
Figure 4.4: Apartments in Yeniboğaziçi Village	71

Chapter 1

INTRODUCTION

House can be defined as an architectural solution for sheltering a family and providing suitable conditions for living. Sheltering, which can simply be defined as a basic attempt of need in protection against natural conditions and other possible dangers have been interpreted as the major motivation for building a house. Since man does not possess the biological characteristics that other creatures have that enable them to adapt to environmental conditions, certain other measures had to be taken to ensure that he would be able to do so (Sey, 1999). But this motivation originated from biological needs evolved into a quite complex level in nowadays understanding as search of suitable conditions for living. Tozan (2000) emphasized that technological advancements have increased the dynamics on house, like all other building types, into a great changing process since the industrial revolution. Rapid urbanization has also influenced the housing solutions. Alternative to traditional urban and rural settlements, new living ideas were in processes to try to provide innovative lifestyles for modernized societies, such as Ebenezer Howard's Garden City movement, Le Corbusier's city plans and housing schemes. "House" as a unit for living has been subject to transformation more than ever.

1.1 Background of the Study

House has started to change in order to fulfil the revised needs of the users in a continuous manner. According to Gür (2000), house is an organized structure of communication, interaction, space, time and meaning. Users' preferences,

backgrounds, expectations, income levels play great importance on their spatial behaviors and interiors of their living spaces. Additional to users' profile society and traditions and local weather tend to be actively playing important role in home design and style. Lifestyle can be a multi-dimensioned subject which is included in a great variety of research.

It is more common to analyze the daily living and gathering spaces in order to provide information about those subjects mentioned above than about more private spaces like bedrooms. The importance of daily living spaces and complexity in its nature dates back to the very early phases of history. Usage of fire/fireplace at the center of the house that has been named as "heart" has been very important in domestic architecture since the early periods. Daily facilities have organized around fireplace such as cooking, sitting and eating. The living ideas have evolved through centuries in various civilizations. But the continuous habit of gathering, cooking and dining gained great importance in the setting of domestic architecture in various cultures. Especially living room and kitchens are very important to trace functional complexities of daily living and dining, cultural ways of realization of functions, segregations according to privacy levels, adaptability for rituals and gathering, representation of personal preferences, and religious symbols.

Additional to traditional house building processes, nowadays we are able to see many attempts to create and also construct houses in certain sizes in a variety of techniques and forms without having real user requirements. These are basically the constructing processes of the investors' without individual design requirements. Along with these different methods, there has been an opportunity to understand various sort of attitudes

to local structures though in fact many of us assume there are a few features that are carried on over a long time within human being lifetime.

Interior spaces in various periods have been explicate and considered by different cultural groups with their designers. According to the interior spaces, their organizations, the elements and decorations provide different tendencies according to culture and styles. Alternative methods of owning a house and changing lifestyles have brought several problems in cultural continuities.

1.2 Problem Statement

By the beginning of the twentieth century, it appeared that buildings had been started to change in several developing countries, for instance, the contemporary system seemed to be substituted with traditional/vernacular design. “This transformation happened therefore quickly and it showed substitution instead of adaptation” (Behsh, 1993). Consequently, Behsh points out that according to these kind of modifications and within the new sort of homes, people cannot follow their own traditional habits and also their particular cultures’ of lifestyle.

Thus, conversations concerning rediscovering standard architectures are eternal common options and a few experts claim that the most up-to-date technology should be taken into account, although to do so a house must be designed in a way to help sustaining social values and typical way of life (Mirmoghtadaei, 2009).

This thesis is an attempt to investigate values related to “living spaces” in history of Northern Cyprus and searched their validity in contemporary life. Villages next to the cities including Yeniboğaziçi went into transformations, changes and continuities in domestic architecture and spatial organization. There are discussions about

rediscovering vernacular architecture's timeless, universal values. Domestic architecture and spatial organization of living room and kitchen spaces in houses were analyzed to arouse awareness about important local values to provide new perspectives to designers. This thesis aims to answer the following research questions:

- How are the developments of living environments at rural settlements affected by the urban expansions?
- What are the characteristics of vernacular living in Yeniboğaziçi village, Northern Cyprus?
- What are the continuities from vernacular living to the contemporary living spaces (i.e., living room & kitchen) in Yeniboğaziçi?

1.3 Aim of the Study

The present study aimed to re-define the specific characteristics of living spaces of vernacular architecture in Northern Cyprus in the case of Yeniboğaziçi village. The first purpose of the study was to emphasize the importance of the inherited values of living spaces in vernacular architecture, and at the same time to inspire the designers to use these values in their future designs.

The second purpose of the study was to define continuities and discontinuities of interior characteristics of living spaces in recent housing developments in Yeniboğaziçi. This findings of the study provided more insight into the dangers in relation to local life and architecture in Yeniboğaziçi village. Additionally, the study provided data about Yeniboğaziçi Municipality for future planning, especially in the recently started “Citta Slow” membership process.

Last but not least, this research can motivate governmental authorities and non-governmental organizations to take a planned step for the protection of the local values for the future of the Northern Cyprus in general and Yeniboğaziçi village in particular.

1.4 Methodology

Data for this research was based on the literature review and fieldwork consisting a case study on a series of selected houses at Yeniboğaziçi village. Available literature related to the topics of this thesis were reviewed as listed below:

- Definition of house and home, and factors effecting interior organization of house;
- Spatial organization of living room and kitchen spaces in vernacular and nowadays' conditions in Northern Cyprus;
- Characteristics and elements of living room and kitchen spaces; and
- Culture and life style

As a case study, this research focused on some selected house cases from built at various times in Yeniboğaziçi village. The goal was to analyze living room and kitchen spaces of those houses which had been built at different times and based on different requirements in order to understand the interiors of living. Studies examining living room and kitchen spaces used observations, sketches and photograph of houses as methods of data analysis. The sample of living room and kitchen spaces were evaluated according to traditional living patterns. These studies were reviewed in an attempt to determine changes and continuities in domestic architecture and spatial organization.

Literature and field survey guided the researcher to evaluate three groups of houses in this case study. Group one are houses that have contemporary characteristics dating

back to the second half of twentieth century. Group two contains single houses with recent building dates. Group three are multi-unit apartment blocks with recent building dates. Building dates and type of the houses have been the main indicators of the three house groups.

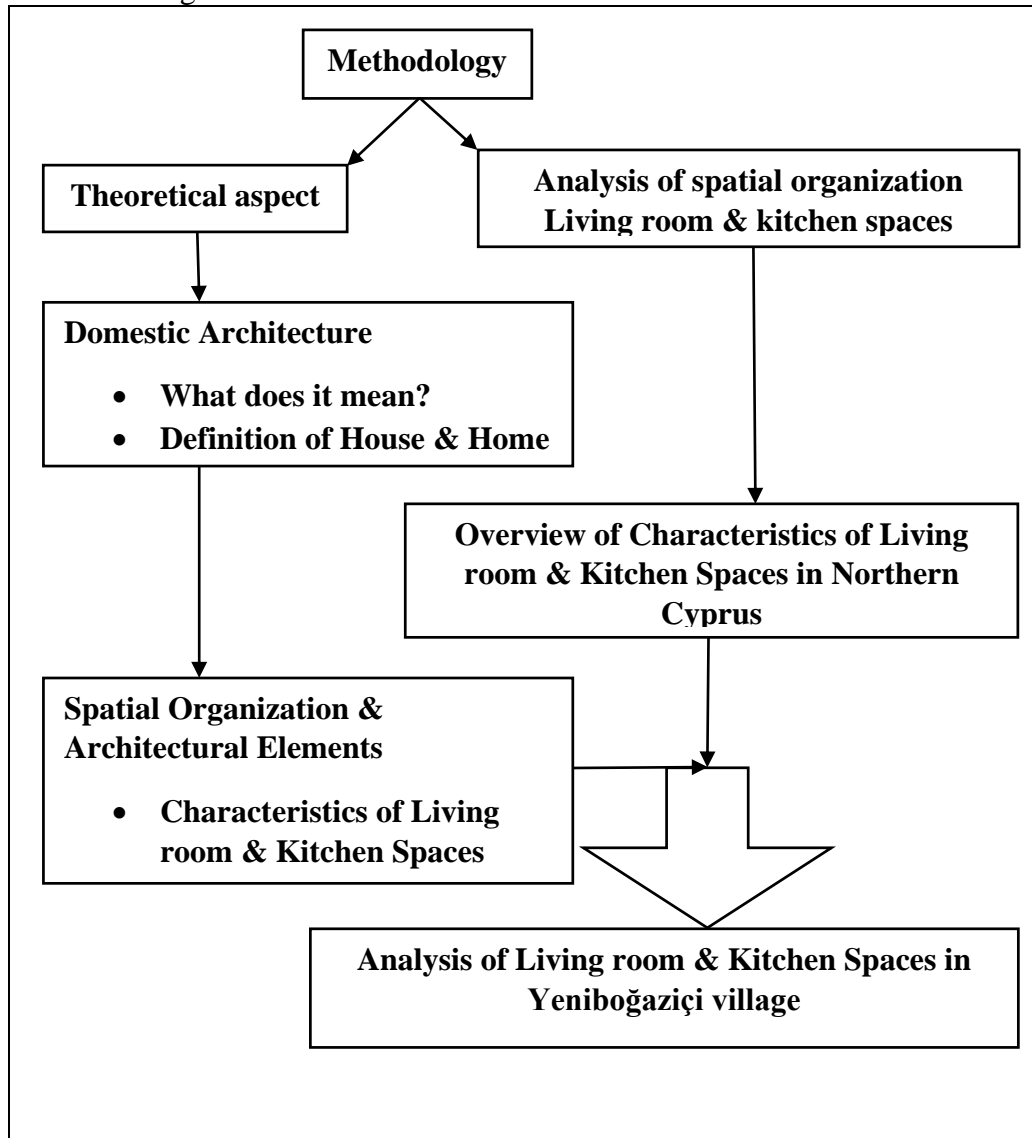
1.5 Limitations

Although this study yielded useful findings, it had some limitations. First, this study focused on house interiors only in living room and kitchen spaces at Yeniboğaziçi village, Northern Cyprus. However, investigating other house spaces like bedrooms, dining rooms or outer spaces such as the backyard and balcony can shed more light on the continuities of vernacular living to the present developments.

Moreover, major discussions in this study were based on user preferences, lifestyle, culture, and technology. Nevertheless, this issue can also be discussed considering other factors including, for instance, urban texture, the village's climate and geographical position.

In this study, fifteen cases of houses at Yeniboğaziçi village were selected from various building dates in order to give opportunity to trace the levels of changing in living environments in a balanced way until today. However, to provide more information larger number of cases can be involved in future studies.

Table 1.1: Organization and the Structure of the Thesis

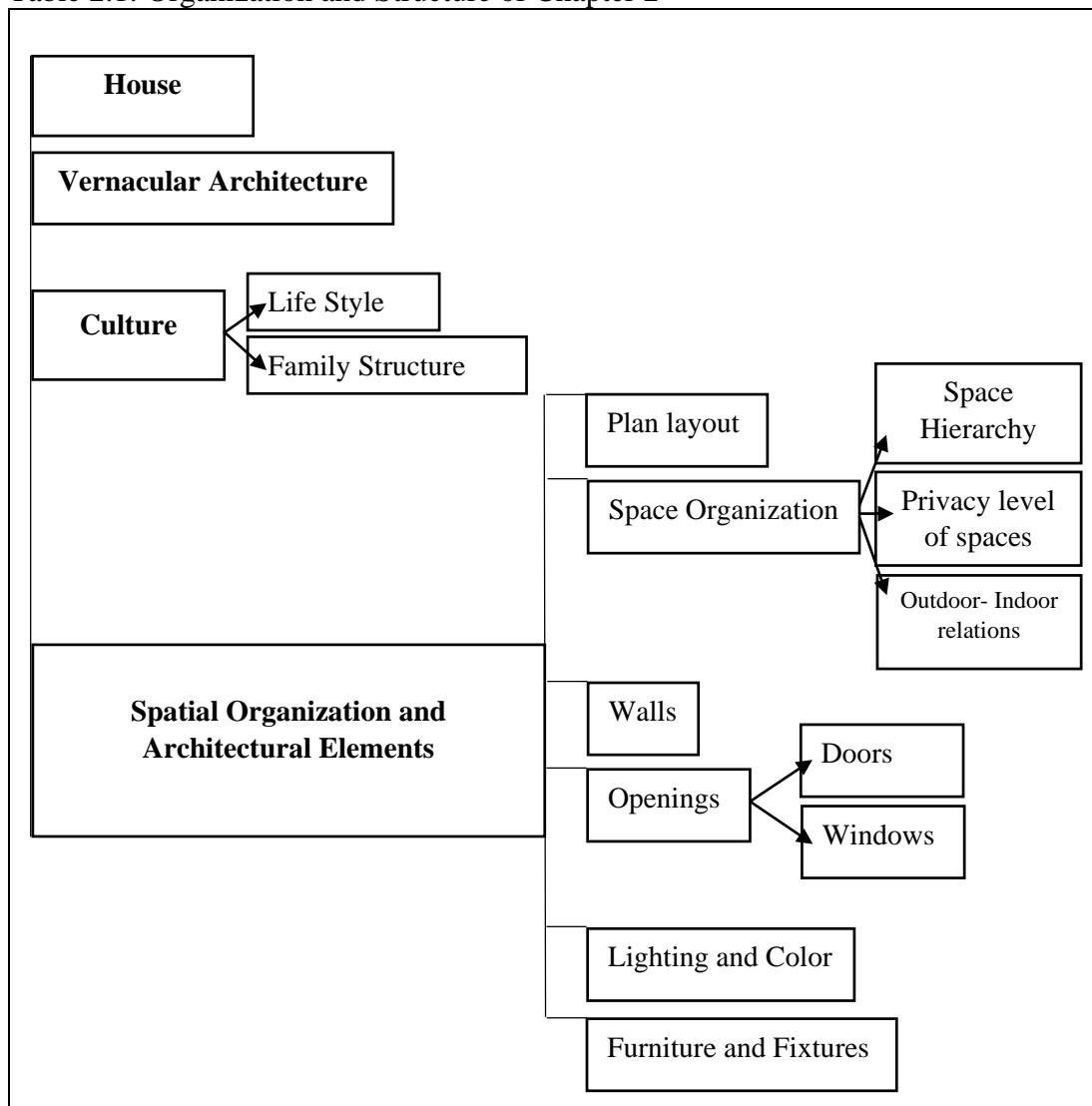


Chapter 2

THEORETICAL ASPECTS OF SPACE

“Architecture is basically a container of something.
I hope they will enjoy not so much the teacup, but the tea”.
Yoshio Taniguchi (Architect)

Table 2.1: Organization and Structure of Chapter 2



Kent (1990) believe that “architecture creates boundaries out of otherwise unbounded space while the use of space can be seen as a means to organize that unbounded space”.

2.1 Domestic Architecture

Domestic architecture refers to the connectivity between architecture and interior design. It emphasizes on interior spaces. According to definition of function of space, separation interior spaces to several spaces for instance; living room, kitchen, dining room and bed room in houses’ function is shaped by architectural elements, plan layout, space organization, walls, openings, lighting and color, furniture and fixtures.

Domestic architecture tries to communicate meaning by creating a set of do's and don'ts, plurality and shortcomings, and putting form against form, and space ‘nature of the geometry (organic architecture)’ inside out.

As it was mentioned above, domestic architecture includes of knowledge, technique and art that try to construct a proper functioning for answer to user’s needs considering to cultures and life style.

Domestic architecture is usually a representation of the culture which generated it. Culture and time period are two important factors influencing the type of space. A community consists of lots of people, each giving rise to their national lifestyle. Domestic architecture includes a much more steady information, that is, the —challenge of the past and also the reasonably— competitive discourse (Noel, 2011).

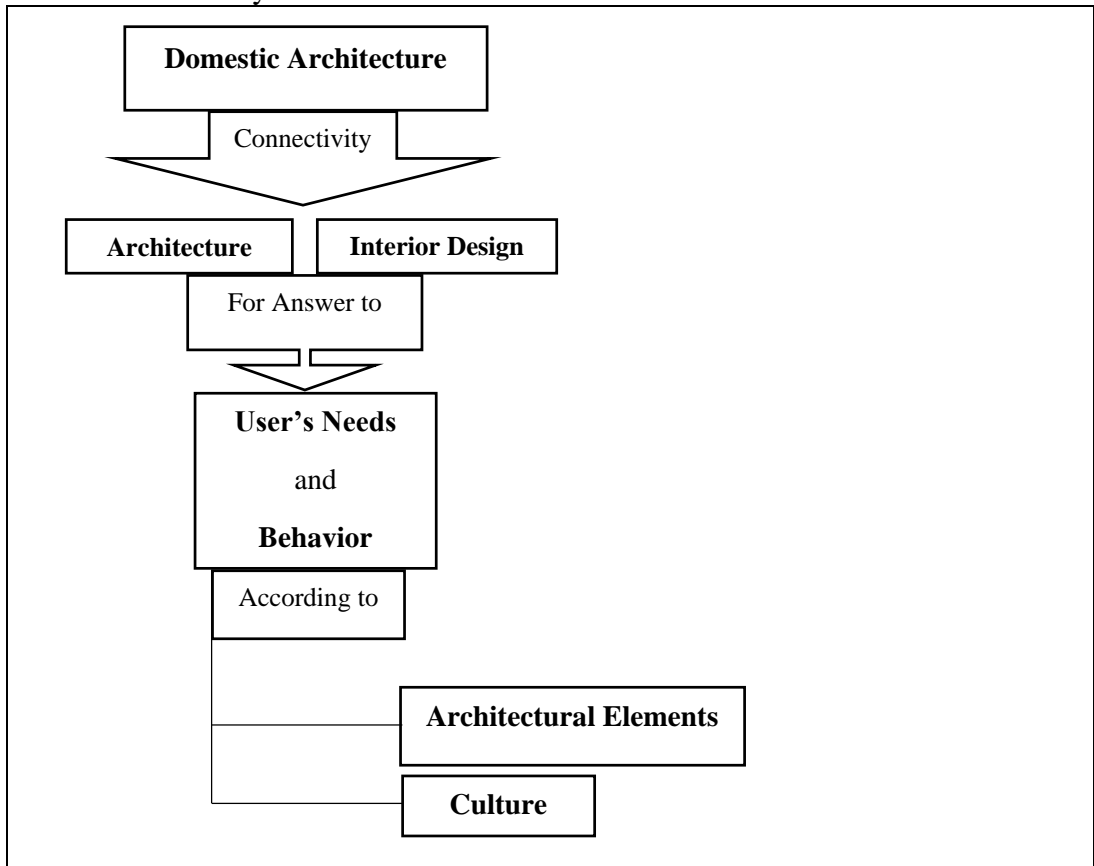
Adeyemi (1976) recommended that the innovative performance of the architect is definitely an expression of the interior becoming and the social aims and also the

national beliefs of that time period. Clearly, the function will be the reflection of the culture.

Lifestyle is one of the adjustable factors affecting actual features and spatial corporation of internal places and also their particular utilizes. As simply expressed by Rapoport (1977), lifestyle “consists of manner, rules, choices, role allocation and allocation of resources of a society”. This item takes on a vital role within the organization of city design. Considering that towns consist of diverse groups of people along with their unique standards of living, belonging to various communities conveys the meaning that they represent and point out to their position and also societal identification. For example, in a city circumstance, it contributes to the variation among the yard as a wide open place, it is also a great sign of position, a property like a shelter and also a representation of societal identification.

Design and culture that give delight to a person’s and a generation’s way of living have the potential to supply people with pleasure to other people a lot eliminated in time and area; the particular continuity in the world gives a corresponding continuity throughout man’s words.

Table 2.2: Summary of the Domestic Architecture



House are the main spaces in domestic architecture. Domestic architecture can be constant in the home furniture used from the specific period of time, or perhaps higher personality may derive from a great eclectic selection of components through a variety of times which are harmonious in style, color, consistency, and also nature. Matching the entire gets an innovative experience, as focus is put on visual interactions rather than designs.

Most cultures, ancient or even superior, have developed their unique house forms. The property is intimately linked with the particular everyday life of people and thus firmly tied up with all the family members that one are not able to visualize any kind of enduring human being community that will not produce a unique home convention (Kuban, 1986).

Architecture of a specific area ought to indicate the actual lifestyle, values in addition to customs of the people living there. That is why Denyer (1978) explains property (house) as a symbol of the socio-cultural history of the individuals and lifestyle; tradition, as a result, exercises a powerful effect on the forms and varieties of homes.

It might thus be emphasized that home structure can be a product of tradition particularly materials tradition. Materials culture involves materials and also symbols; home structure is one of those objects. The meaning given to materials, symbols plus the norms, ideals and also beliefs by people that will saturate cultural living is actually what distinguishes a specific structure from another. It really is clear that several parts of this kind of lifestyle has been modified although other regions continue to persist. Consequently, change within socio-cultural elements together with continuity might be associated with home structure (Noel, 2011). Endeavors have been accordingly

designed to provide an improved knowledge of these types of elements and the reaction of the inhabitants of Northern Cyprus to these modified types of elements \and also continuity through the years.

2.1.1 Definition of House and Home Term

Any individual requires his own territory. The actual need of property and the property of inside areas results in a requirement for particular areas to live in (Ardrey, 1966). Home setting is actually a place where individuals experience a feeling of possession as well as management (Katz, Gaventa & Weiss, 1998; Rutman & Freedman, 1988). The internal living space of home, in particular, can be a location of territorial centering, that all of us venture forth and also to that we go back (Buttimer, 1980; Rubinstein, 1989).

As mentioned above, house is the main space among other spaces in domestic architecture. A house is viewed differently from different perspectives. For an architect, it may be a composition of spaces whereas for a painter, it may be defined as a combination of planes distinguished by their colors. Inhabitants, on the other hand, tend to describe a house in terms of rooms along with the things inside them including furniture and artwork that make a space distinct from the other spaces (Habraken, 1998).

House type is not necessarily characterized by a specific social entity. Once houses were built for extended families but, today, they are like small villages inhabited by a number of working-class unclear family households (Habraken, 1998). However, throughout the decades, mankind has experienced a lot of varieties of the homes. Home includes a meaning of greater than a shelter. It is just a container for individual belongings, a representation of self plus a reflection of cultural conditions and also

values. (Crisp, 1998) It gives a clue about inhabitants' attributes. It can be structured according to user selections in addition to wants. It may not just reveal personal inclinations, but also reflects personal characteristics, like extroversion or introversion states, that are emerged in the house setting (Gosling, Ko, Mannarelli & Morris, 2002).

As mentioned above, a home is structured according to demands and needs of an individual so it can be considered as a private area separated from public places. As stated by Madanipour (2003) and Wekerle (1991), home can be accepted as a symbolic representation in addition to materialization of personal region so, it indicates possessing selection and control over one's private atmosphere. It offers a private place and makes a person capable of contacting with other people by indicating their personality and strength (Klassen, 2001).

2.2 Vernacular Architecture

Vernacular architecture as one of all architecture kind is known by its strong stress on locality of culture, material, level of technology/ technique and socio-cultural structure as well as regional climatic factors. Vernacular architecture in general is something that is not new but old; something that belongs not to this day and age, but to a time that has now gone. At the same time, the use of the term reflects the notion that 'old' vernacular architecture possesses certain qualities that contemporary forms of architecture do not and that thus make it worthwhile to study, learn from and emulate it, in order to create 'new' vernaculars (Arab, 2012).

On the other hand, by entering to the 21st century and its technological advancements that is crossing the physical limits one after other, redefining the meaning of space, distance and changing the value of the time, totally different social structure is

appearing which is causing the emerge of new approaches in the study of vernacular architecture among scholars. The new era is structured based on new technology, not only changes the life style, but also introduces new activities in addition to new possibility beyond the possibilities before.

Architecture as art of designing space to have a place for any type of activities, has the most immediate touch with the human being's daily life. Vernacular as one architectural kind, by its own characteristics that is stressing on context, climate, efficiency and the people, could be the most reliable stage of showing the changes and its influences on human being's daily life.

2.3 Culture

There are several descriptions of culture that are being used in different fields of studies like social psychology, sociology, and anthropology. Culture is a broad phenomenon covering a variety of attributes as defined by different scholars. It generally refers to a body of values, knowledge, art, traditions, customs and alike abilities, capabilities and habits learned by human being as a member of the society that are acquired, protected, sustained and passed to the next generations through education (Tylor, 1998). This implies that this body of values or habits is shared by members of a particular community in different aspects of their daily lives and social activities that represents their individual and national personalities (Poyatos, 1972). Culture is a unique phenomenon in the sense that, on the one hand, it forms human beings, and on the other hand, it is formed by human beings (Özlem, 1986).

Culture also includes the components of technology, symbolism and world view, economics, social structure, and political organization (Kent, 1990); that is why it

contributes to the interaction between architecture and the use of space of culture and it is considered as an important factor in the form and design of the house (Rapoport, 1980). Rapoport (1980) analysis has shown that cultural elements such as values and images, religious beliefs, family structure and social relationships between individuals have a role to play in the form of the house and subsequently the life styles and activities. Similarly, Altman (1980) observed the reflection of culture and environment in houses.

The cultural components related with the house in micro and meso scale take charge of the contents; family structure; life style and basic needs belonging to the house, religious, privacy, and social intercourse. In this classification the most important point that needs be considered is that from time to time these components are overtaken by one another and complete each other (Ilkin, 2000).

Family structure as a cultural component is another determining factor influencing the design of a house. According to Rapoport (1969), different family structures has an effect upon the design of a house. For instance, in big families, the size of the house is different from that in small families.

The way a house space is used is also influenced by culture and is open to change in different societies based on their sitting habits, and habits related to eating such as preparing and having meal, to name a few. Therefore, the interior house life style and its appearance is a cultural components and ways of using different spaces in a house particularly kitchen and living space represent behavioral mechanisms and determine appearance of space activities (Ilkin, 2000).

To elaborate this issue few example are provided here. The sitting well as the living habits can determine the form of the house. In some parts of Asia people rest by squatting but in some parts of Africa and Australia aborigines stand on once foot. As a result, the shape of furniture would be affected by different postures (Rapoport, 1969). As another example, in America, different eating habits, family having their meals altogether or separately has influenced the shape and space organization of the house (Rapoport, 1969).

2.4 Spatial Organization and Architectural Elements

2.4.1 Plan Layout

Spatial organization is highly influenced by the elements defined by architecture.

Ching (2007) defines three preliminary elements for design: point, line and plane in all of matters.

Point is the first figurative form. Line starts with point and finish with another point. And plane can makes with line. With moving plane, form will be make. Thereupon, in the architectural elements plan that is a main and basic element will be makes with form. As mentioned before, plan is a basically architectural element for defining the boundaries and making the inside and outside. But the interior space is not perfect with just a plan layout. Therefore, with other kind of architectural elements that as said above, the plan layout have meaning.

2.4.2 Space Organization

Space is a basic component inside a designer's color palette and also an essential element in home design (Ching, 2005). On the whole, using proper angled geometric factors assists to specify the inside space's closure. As a result, the difference between interior and exterior areas are identified. As well as suitable angled associations

between geometric factors, indoor places can be created through the use of non-right angled associations to determine the closures (Pile, 1995).

The meaning of a space occurs with design and it is usually varied as an external and internal area. Executive components of spaces (walls, flooring and ceilings) plus the furniture aid to generate a series of spaces inside building. Space ought to not just design for artistic reasons, it should in additionally respond to man requirements. Also, space can be aesthetically extended by using of light, shade, consistency and style (Nielson & Taylor, 1994).

In accordance with Miess (1990), place is described as “a jar of things-a kind of sequence of all-inclusive cover, from what exactly is ‘within the restrictions of the sky’ towards the tiniest factors. Place can be for that reason, restricted externally and also filled up internally. There is not any vacant place; everything possesses its position, its area, and its particular place” (Miess, 1990). Actually, the architect typically offers it the cement to provide hospitality as well as relative independence of activity that individuals need.

Designing involves many approaches to describe geometry and form (Kaynama, 2014). Architects usually resort to geometric principles or aesthetics when solving spaces. Interior designers also pay attention to design elements like scale, form and size when selecting furniture so they fit the desired space and match other furnishings around it (Brown, 2002).

Area is actually identified as the development of inside and outside quantities, the intervals, the interrelationship, associations among individuals and individuals, behavior of materials and factors (Fasli, 1997; Isaac, 1972).

Several widespread viewpoints may be created in regards to the enclosure of space. As explained by Isaac (1972) “a space may be defined visually and/ or physically by the use of structures, by enclosure planes (vertical, horizontal or inclined), by individual or group of elements within the field of vision. A space may be partially or fully enclosed, or merely a collection of elements in the background”.

Every space includes a form, size, substance, texture as well as other characteristics which ideal exhibit and support the functionality is actually the space is supposed. Because space have higher value by the living of people, it should satisfy mental, physical in addition to cultural requirements besides the well-designed elements. It can be obvious that, people behaviors form the space and the physical atmosphere influential on people actions. On the whole, utilization of proper angled geometric factors assistance to establish the inside spaces' closure. Hence the difference among interior and exterior outside spaces are identified. In addition to proper angled associations among geometric elements, inside spaces can be created by use the non-right angled interactions to help outline the closures (Pile, 1995).

Pursuant to Aristotle as well as Ergüden, space is usually explained with distinct limitations such as sky, earth, blossoms, as well as trees. And also inside structures it is usually described by flooring, roofing, planar partitions, columns, in addition to lighting which they shaped with stage, series, plane and size. Actually, the architect

typically offers that a cement from to provide hospitality along with relative liberty of activity which usually persons require.

Environment can be an integrally prepared, organized and also designed connection among people and people, people as well as items and also items and items (Boğaç, 2005). These kind of relationships are generally reviewed at people's each day workouts and also explanation of options that come with these kind of workouts is actually how individuals reside in and also move across distinct spaces. According to people unique conditions they will sense and act in different ways in spaces. Through the private space of the house towards the semi-private space of the school or even work environment and the public area in the active city streets; everyone is positioned in distinct situations every moment (Madanipour, 2003).

Semi-public along with semi-private places have been in among public and non-public quantities. The actual uses of these sorts of areas are usually permitted to a particular number of individuals, for example whoever has an appropriate cause to do so and family members which are living along with their close friends (Fasli, 1997).

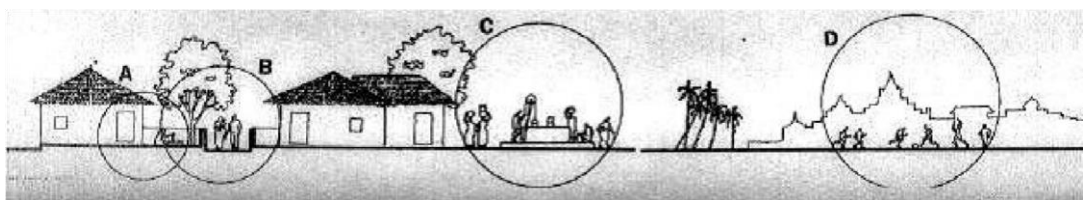


Figure 2.1: Hierarchy of spaces, private, semi-private, communal spaces (Correa, 1985)

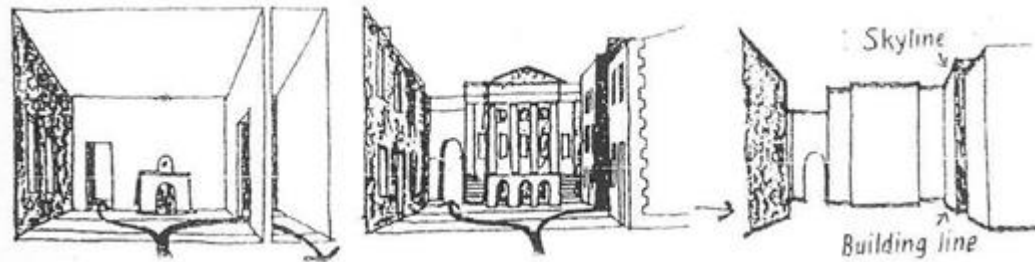


Figure 2.2: The Interior and Exterior of spaces (Fasli, 1997)

Interior space is a type of closed space, which provides a sense of security. The primary element of interior design is the planar element but it is not limited to points followed by lines combined to create the final object; rather, elements can be three dimensional (Ching, 1987). Interior space relies on its enclosure. It is a type of architectural place to provide a protection and also great level of privacy to its consumers (Fasli, 1997).

Internal spaces are firstly shaped through the building's structural method, even more outlined by the walls, floor along with ceiling surfaces. Described factors are in connection with some other areas by doors and windows. They are the primary components shaping internal places. They are collected together in order to outline the area enclosure when they are functionally connected together (Ching 2005).

The livable space is not just the place to rest and also sit down in comfort; it can be as an exhibition area in the house in which individuals can display their styles. So, there are kinds of architectural elements that interior spaces can be defined by them. All architectural elements should be work together because if use them alone they do not have meaning. The major architectural elements like walls, floor, ceiling, openings (doors and windows), light, color, furnishing and fixtures help to generate a series of interior spaces.

2.4.3 Walls

Walls are constant elements of any interior spaces. They are one of the most important elements when planning a building, because of their aesthetical mission, provision of security and privacy as well as protection from the climatic factors for interior spaces (Ching, 2007). In another words, “they are used as physical and a visual boundary” (Ozay, 1998).

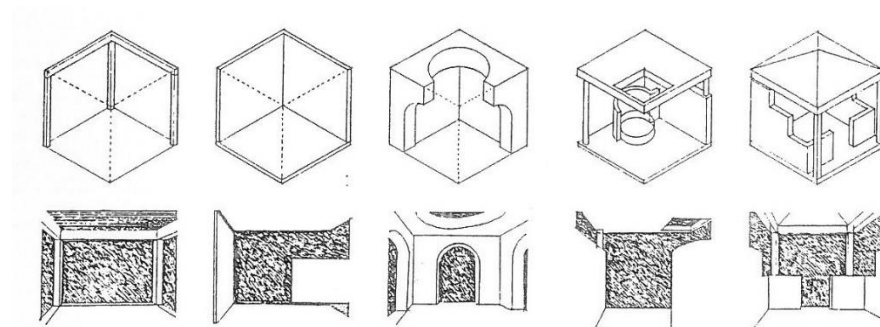


Figure 2.3: Walls (Ching, 1987)

The effective use of walls gives both solitude and safety from the weather elements for indoor areas (Ching, 2007). Walls are the vertical factors which encompass and separate inside areas, so assisting to enclose, independent and generate various internal areas. They have a great influence like a spatial boundary and a filter to mobility. Walls in addition help separate distinct capabilities from one another. (Faulkner, 1979) Partition walls, for instance are utilized to separate the interlocking areas; they are able to either become load bearing walls or maybe not necessarily (Ergüden, 2012).

2.4.4 Openings

The opening inside a wall offers a passageway for light, temperature and audio. Doors and windows, aesthetically in addition to physically, work as a transitional component of interior planning connecting one particular area to another within out there. Walls

create places, while windows and doors assistance to join these kinds of places both visually and also physically (Kalinkara, 2006).

The size of the opening in the walls or maybe ceiling planes, even so, can be based on extra elements besides light, like the materials and structure of the walls or even roof planes, needs for aesthetic comfort, and enclosure of the areas, or the opening's influence on the building's outdoor form and physical appearance (Ongul, 1998).

Windows are related to the façade and influenced by both exterior and interior of a building. The dimensions- proportions, style and color of windows give different characters to buildings (Ozay, 1998).

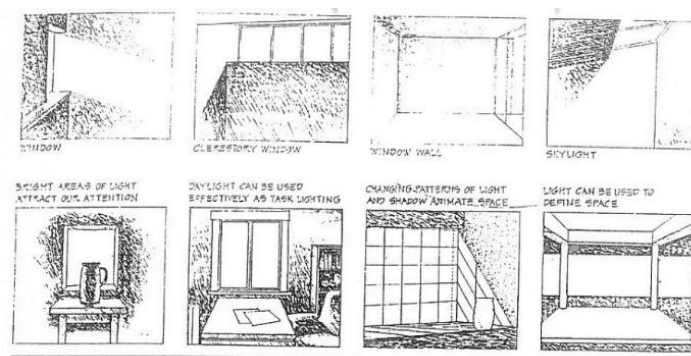


Figure 2.4: Different Windows (Ching, 1987)

Internal windows utilized in an inside room, aesthetically develop a space letting it to act in general within internal areas. Windows in addition have some other critical operates, for example supplying comfort, framework the actual view, and handling the entrance of light as well as heat obtain for indoor places (Ergüden, 2012).

Doors assist individuals get into the inner areas. 'Doorways supply physical accessibility from one place to another. While shut, they close an area off from

surrounding areas. While open, they set up visual and spatial in addition to acoustical links among spaces' (Ching, 2005). They supply light, audio, smell, and wind flow and warmth changes between rooms in addition to control the circulation within internal spaces (Kalinkara, 2006). Doors supply a control for pathways, visual solitude, audio solitude, safety, light control and also provide an attractive perform within internal rooms (Ballast, 1998).

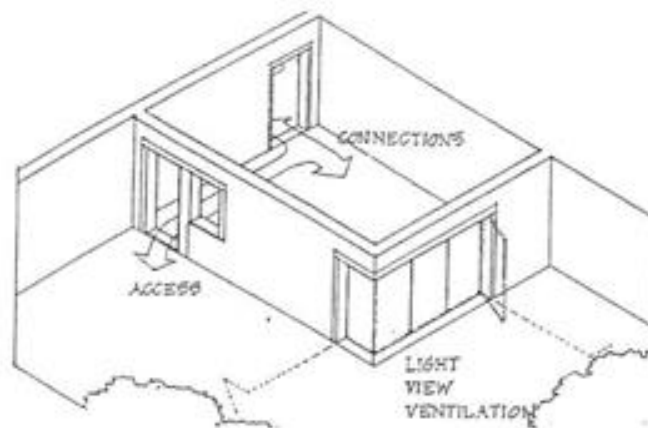


Figure 2.5: Different Doors (Ching, 1987)

2.4.5 Lighting and Color

Without light, perspective is not probable (Denel, 1979). Sunlight is an abundant source of light for the brightness of types and design. With the aid of these lights, various motifs are made on the varieties in addition to shapes. When source of light for the artwork occurs naturally, the standard of light and the visual appeal of artwork alter with all the period, and also from season to season.

Getting into an area through windows inside walls plane, or even by way of skylights inside ceiling plane, noticed the sun's lighting fall upon floors in the area, enlivens their own colors, and articulates their own textures as well as allows to build the artwork. By using the modifying designs of light and color which is makes, the sun's

ray animates the space of the area and also articulates the types on inside it. The size of the windows as well as skylight can, certainly, manage the amount of brightness an area gets. The place and of the windows or even skylight, as a result, might be much more crucial than its dimension in identifying the standard of sunlight an area obtains.

Next to these kinds of natural source of light, individuals are generate some various motifs by utilizing the artificial source of light. The materials which have been used in the unnatural resources impact light. Direct light gives a large amount of brightness which is in particularly extreme though it's open. That makes sharp motifs of light and dark on the floors of the space, along with crisply articulates the particular types inside the place. Throughout artwork light works more effectively about three dimensional motifs, since light, darkness and color make it possible to obtain a three dimensional perspective of quantities and masses. (Ching, 1979) The path, shade, high quality and power of light which illuminates the outer lining impacts the particular notion of artwork. (Denel, 1979) Direct light or even diffused lighting decreasing throughout a surface area provides diverse darkness along with dim patterns (Ongul, 1998). Shade can be an important element in any kind of interior.

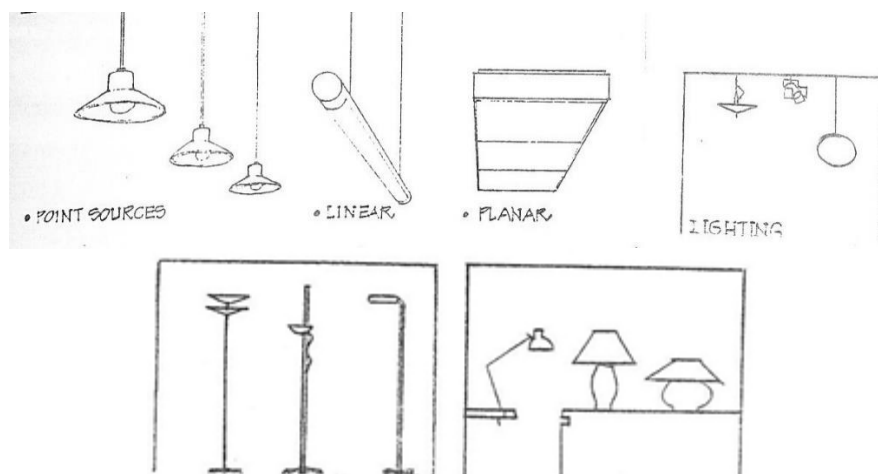


Figure 2.6: Lighting Fixtures (Ching, 1987)

Color is the part of artwork in order to that the man will be most sensitive. Coloring is one of the most significant components since its high quality has an effect on the feelings directly and quickly. It can obviously possess a dominating influence on the sense of a room-in both physical and also emotional feelings. (Sudjic, 1984) Shade creatures along with and comes from light, both natural and unnatural. Wherever there is small lighting, there exists very little shade; in which the light is solid, color will probably be especially strong. When the light is fragile, for example at night or even dawn, it truly is hard to recognized one shade from another.

2.4.6 Furniture and Fixture

Furniture and fixtures are the fixed and moving elements of spaces which are the wardrobe fitting, curtain fitting, table, chair and etc. Besides the various consumer organizations, routines, operates and interactions between places, furthermore the number of place for unique perform ought to be identified. Even though figuring out the desired place for particular operates, the required furniture as well as specific needs which belong to the consumers are essential. Way of living profiles will assist with estimate the necessary place. (Nielson, 1994) These types of elements affect the design of the inside environment.

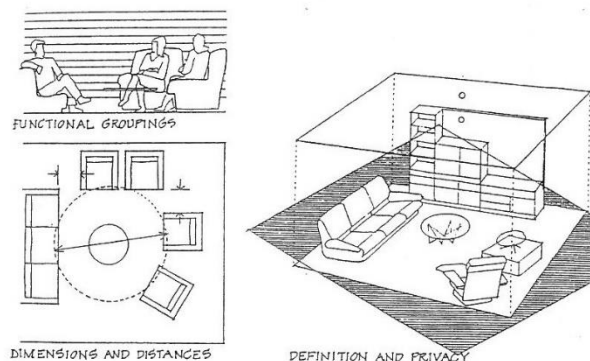


Figure 2.7: Different Furniture Organization in Living Spaces (Ching, 1987)

Furnishings will surely have an important portion to perform in determining the standard and also character of an area. (Sudjic, 1984) furniture, particularly for the inner places, load a message for making places private and reveal user's character (Kalinkara, 2006). Furnishings change neutral places directly into private and also unique places for individuals (URL 1). Furnishings consist of furniture, materials, and arts along with equipment for internal places (Ergüden, 2012).

Since walls, floors and also ceilings are the important regions of architectural layout of a place, using furniture are the vital items for indoor place. Furniture are section of inside areas and also major executive factors (walls, floors and also ceilings) making a history for their utilization. Furnishings are usually important parts and goods for the pattern of indoor spaces. They create decorations habitable by giving ease and comfort in addition to adjusting throughout form of an activity. (Ching, 2005) Individuals would rather use furniture as they aid preserving peoples' pursuits inside a much more comfortable way. Home furniture are exclusive and also gnomonic goods in person's life in order to adapt the kind of an action. As well as satisfy certain operates, furniture ought to be adjustable to the character of task. The shape, line, coloring, consistency and also the size of decorating products additionally influence the sort of an action. Furniture, therefore, provide persons an opportunity to an operating for various functions inside the architectural components - walls, flooring as well as ceilings. Furniture are generally chosen according to user options and desires. There is no specific principle that ought to be followed. They will alter from style to style, one person to another and gives a change between inside area and the persons. (Ching, 2005)The way of utilizing furniture influences using a place. Circulation and movement between rooms can also be affected by furniture. Whenever furniture are

placed by skilled individuals linked to room design, they offer comfortable activity inside a space (Mitton & Nystuen 2011).

Requirement and using of furniture are not completely new in today's world. It is developed and created parallel to the wants and needs of people. The shape, size, materials along with dimensions of a redecorating are made conveniently with the circumstances of each historic time. The function of furnishing within the layout history additionally will take part even though creating internal places (Ergüden, 2012).

Based on Ching (2005), because walls, floors, ceilings, doors and windows determine the architectural style of any constructing; furniture are the variety and design of movable interior planning components. These are found in inside areas and measured as a movable kind of furniture. The placement of furniture can modify simply within internal spaces, because their areas are certainly not precise and prerequisite.

The overall uses of soft furniture primarily happen within the indoor spaces. The historic study of inside organization of places is usually has become interested in the development of room planning, indoor architecture, attractive aspect and furniture. (Blakemore, 2006) Thus, the historic review of various times provides a hint about using soft furniture ; the primary utilization location, exactly how it is began to be used generally within internal spaces and exactly how it gets essential day-to-day. It helps to know the term soft decorating more deeply throughout the heritage (Ergüden, 2012).

Fixtures as another part of the interior elements are referred to as “small movable objects that complete the interiors” (A. Friedmann, J. F. Pile, F. Wilson, 1979). These can be used as functional or wholly aesthetical, in another word, they are called as decorative fixtures (Figure 2.9). From the smallest ash-tray to antique glassware, paintings, photos or sculptures and lots of things are possible to be grouped under this title. Fixtures, often comes from people of many cultures and regions. For example the simple handcrafted that put on cupboards, tables or cover walls. Briefly, the placement, safety, type, and aesthetical harmony with the other interior elements are important aspects for these objects.

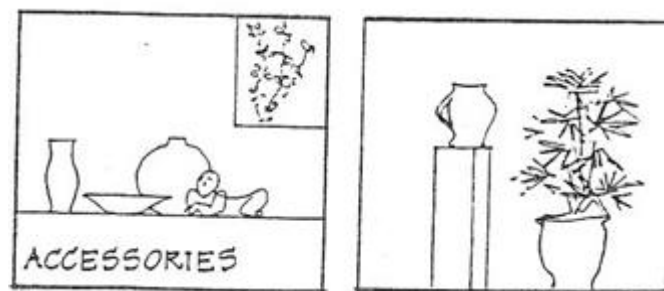


Figure 2.8: Fixtures (Ching, 1987)

2.5 Characteristics of Living Room and Kitchen Interiors

Generally, the form of a house varies from one place to another and is affected by basic activities of human being such as sleeping, sitting, cooking and eating that are highly culture-bound (Lang, 1987) different ways of living requires houses to have specific features based on different cultural traditions, with different environmental conditions (Norberg.Schulz, 1980). So, space organization in a house is both dimensional, spatial (Lang, 1987).

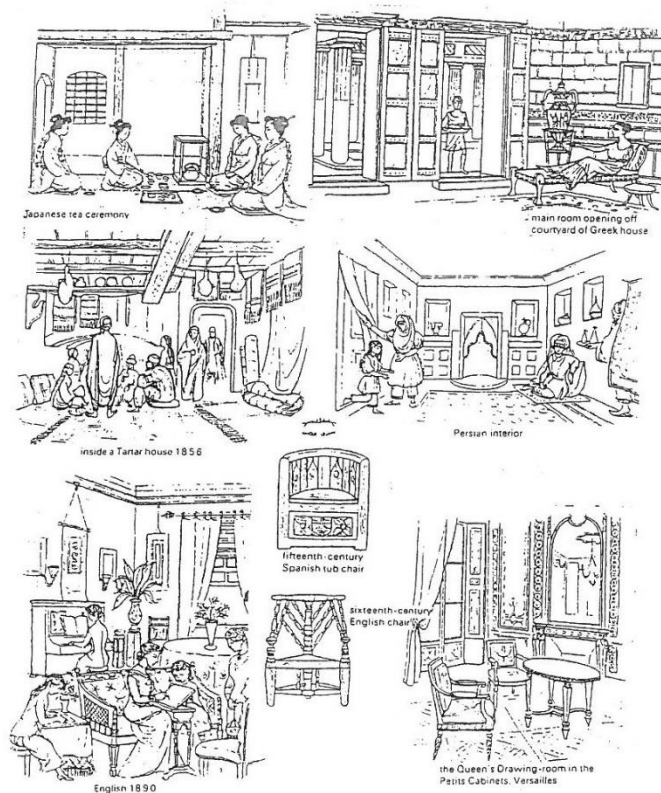


Figure 2.9: Interior Spaces of Various Cultures (Alsaç, 1996)

Houses consist of various areas in order to residing in. There are primarily consisted the particular entrance corridor, living area, kitchen area, bedroom and bathing room. Each space provides diverse requirements and needs regarding their particular functions (Nielson, 2007). Various functions are supplied by the effective use of different resources.

Between these various areas that constructed a house and a home, living room as the heart and biggest area. As mentioned in previous chapter, living space can carry out certain alternative activities. For example, dining or temporary sleeping. Despite the fact that since early examples kitchen is as one of the most important space, in the past can be seen kitchen used by cooks and servants. Hence, it can be traced that nowadays

living space is very much connected to the kitchen area. So, in subsequent part the characteristics of living and kitchen space will be definition.

Living space is a location where peoples' family members and friends commonly expend lots of time there. This can be a place that must definitely be on display with its behavior. (Wissinger, 1995) The living space is usually the biggest area in the house setting and the majority of public place (Katz, 1998). The living space generally consists of several function; it might be used as a living room, for enjoyable functions, relaxing, watching TV, studying and also for listening to songs (Taylor & Blake, 1998). This is a social place for communicating with people in addition to it is sometimes a play room for kids. Above all, the living space must reveal individuals wants and passions with the selected furniture appropriately (Katz, 1998).

The primary concern is usually perform. (Sorrell, 2000) Livable space must be adaptable and designed based on the various features. For instance, for the enjoyable and socializing uses, livable space must indicate casual appearances. Very careful organizing is usually required for dwelling places to make sure that various activities don't conflict. Other concerns ought to be the primary users and method of spending their particular times in residing areas (Katz, 1998).

Each culture creates the hearts middle of the home-a gathering location for friendliness as well as sustenance. Also today's remarkably functional kitchen is a cultural mecca, higher than basic meals factory. Some people spend more awakening time in the cooking area than in some other room-especially those who care about food-and therefore the kitchen (Sudjic, 1984).

The kitchen principle moved through very radical improvements since the lifetime. Since the twentieth century, it had been just used by cooks and servants and also just what proceeded inside kitchens had not been of almost any kind of problem to the other house residents. Because the foods had been served inside the dining area, the aesthetical aspect of the cooking area had not been important. Whenever servants were eliminated, females started again their responsibilities inside the cooking area. Technical developments would not simplicity the duties which they had to do although just extra much more on top of the rest. While females wanted work not in the cooking area, the kitchen itself had changed right into a multifunctional place which was as important as all of other home with regards to aesthetics. (Tehrani. 2012)

These days lots of time and also income is usually used in within the kitchen area to produce it more desirable for friends and family the same. Inside today's cooking area, you'll find a number of methods of enhance effectiveness around it to lessen time used for clean-up and preparing food. Kitchen area is one of the most critical places at home. Anyone who spends amount of time in the kitchen is aware that it is an essential section of the home. Unless the cooking place can be comfortable, the person will never be pleased in the place. It is the location in which individuals make meals and where eating or even visiting activities happen with close friends (Nielson, 1994).

The kitchen attracts individuals not just for meals, furthermore, it is an area for grow ups in order to gather (Katz, 1998). The kitchen tend to be mostly useful for food preparation reasons however next to this , in addition, it includes casual eating place in which parents can amuse and also is possible for kids expended hours through studying. Additionally they ask for a delicate place which has a carpet for kids in order to play on, a couch as well as television set for resting. (Sorrell, 2000) If the kitchen is

made together with small seating area, seats in addition to couches are utilized with small pillows to be able to obtaining relax in addition to comfortable setting. Thus, the kitchen will be the most specific area in a property.

The most important factors (spatial organization) in the formation of a house and specially living room and kitchen space have an impact evaluated in this chapter. The factors that cause house be separate from a space that just call as a shelter. By the help of these theoretical aspects of space, the characteristics architecture in houses at Northern Cyprus will be evaluate.

Chapter 3

CHARACTERISTICS OF VERNACULAR ARCHITECTURE AT NORTHERN CYPRUS

3.1 Historical Background of Cyprus

A brief overview about Cyprus history will be given in this section. At the beginning early periods of the island will be summarized in chronological order. Then, more detailed information about the periods starting from Ottoman period till today will be given. The main reason behind this structure is to draw the general frame of the deep living culture created by many civilizations in long history of the Island. In order to support the thesis background, closer historical periods will be explained more extensively.

Cyprus is the third biggest Island in the Mediterranean Sea, following Sicily and Sardinia. It is between the Asia and Europe. Furthermore, it generates a boundary between the Northern Syria and Anatolia (P. J. Albrecht, 1994). Mediterranean basin and the surrounding countries have experienced interactions via maritime lines all through the history. Due to its location in the Mediterranean Sea, Cyprus has visited by several civilizations starting from ancient times. These visits were end up by having dominations of those civilizations on the Island and at the same time introduction of their many expertise and experiences.



Figure 3.1: The Location of Cyprus (URL 2)

Cyprus has ruled by many cultures that have created a rich cross-cultural structure with many different cultural features. The earliest findings show that the start of the civilization dates back to the Neolithic era at about 7000 BC. Archeologists have discovered settlements dating through the Copper stone age group (3000-2300 BC), Bronze age group (2500-1900 BC) and also after age range. Then, the Island was ruled by Greeks – Phoenicians (11c B.C), Persians, Roman-Arabs (350-395 A.D.), Byzantine (395-1191), British (1192), Knights Templar (1191-1192), Lusignans (1192-1489), Venetian (1489-1571) and Ottomans (1571-1878) (Ongul, 1998; Tozan, 2000). In 1878 the Ottoman Empire relinquishes the administration of Cyprus to the British Empire. Britain annexed the island in 1925 and until 1960 the island remained as a British Crown Colony. The Republic of Cyprus based on Turkish and Greek representation has been established in 1960 and ended after three years because of the recurred conflicts. During the period in between 1963-74 there was no considerable architectural and other progress achieved by the Turkish people who had an introverted life in Cyprus (Tozan, Akın, 2009). The island of Cyprus is divided into a Southern

Greek-Cypriot and a Northern Turkish-Cypriot region since 1974. In the North, the internationally not recognized Turkish Republic of North Cyprus was founded in 1983 (Kiessel, Besim & Tozan, 2011).

Different identities have been coexisted together in Cyprus. As mentioned above the Island has housed different many civilizations living cultures, farming techniques, technologies, production techniques, religious beliefs and even destructions by the wars since many centuries. In order to give opportunity to understand nowadays - existing- built environment Ottoman, British and Turkish Republic of Northern Cyprus periods will be given below.

3.1.1. Ottoman Period (1571-1878)

The military operation came to an end on 1st August 1571 with the capture of Famagusta (Bağışkan, 2009). At the beginning of the Ottoman rule administrative system and planning of the future have realized. One of the first actions was to announce Nicosia to become an administrative center and for this purpose it was necessary to define the requirements of being reconstructed. It has decided that the eyelet of Cyprus should be composed of the sanjaks (administrative units) of Nicosia, Famagusta, Paphos, Kyrenia, Alanya, İçel, Tarsus and Sis. The Sanjak of Nicosia was to be the Paşa Sancağı (main administrative unit). Under the control of the main administrative units the villages have grouped. From documents compiled in 1572 it emerges that of the 905 villages in Cyprus 76 were abandoned. In order to repopulate the villages, replenish the population as a whole, work the deserted land and make a new start on agriculture and urban renewal projects, those soldiers who had taken part in the campaign were permitted to settle on the Island. For further increase in the population, an order has issued to formulate the population transfer, especially families having various professions from central and southern Anatolia. (Bağışkan,

2009) The selection of the talented craftsman has interpreted as the initiation of production in the country with guidance of those experienced people. And it was a direct way of the transfer of the technical experience and expertise to a new land. However, they regarded to residents' traditions and their life style, faith, language and culture (A. Gazioglu, 1990).

According to Ozay (1998) this 400 years period was the most stable period of time of Cyprus experienced in its history. The local culture was highly influenced by the Ottoman's cultural, religious and economic developments and the Turkish Cypriot identity have fertilized.

At this part of the study there will be information about domestic life and the architectural understanding have studied by several researchers.

New homes, designed for the new lifestyle, had been set up in the Ottoman method; additionally buildings of the Lusignan and Venetian time that were ruined through the battle had been modified to the cultural changes. Therefore current homes preserved and also revitalized (Bağışkan, 2009).

Generally, the results of the Ottoman Period of time have been seen in the houses. Following conquest of the Ottoman, the new settlers moved there from the Ottoman countries. They had diverse way of life. Consequently, they started to construct their homes (Ozay, 1998).

Properties built in the Ottoman time in Cyprus reveal Ottoman and Turkish culture typically. Financial and cultural modifications that had been set in place when the

island came beneath Ottoman administration had been reflected usually in the towns, within the personal world and in the regional environment (Bağışkan, 2009). In order to understand domestic pattern of the period it is useful to understand the characteristics of Turkish house mainly define the traditional/vernacular architecture used in different areas of Anatolia.

The Turkish home had been the world of females, while the world outdoor belonged to males. Behind the walls of the home, ladies did these kinds of domestic work as baking bread, drying fresh fruits and grains, cutting wood for fireplace, preparing meals, cleaning, animal husbandry and also the farming of a little yard. Inside the home enclosure, there were places for the keeping of foodstuff for people and animals as well as for logs (Kuban, 1986).

Throughout Islamic lifetime, solitude can be an essential factor. In the Ottoman Time home which can be recognized “Traditional Turkish House”, homes family living had been separated from exterior through large walls round the courtyards. Courtyards had been screened from outdoors through high walls. Maintenance of solitude in the home and also courtyard had been critical. Areas had been oriented to the courtyard. Service areas had been within direct connection with courtyard. Most of the household actions like cooking, baking, preparing of foods for cold season uses had been performed within the courtyard (Fasli, 1997).

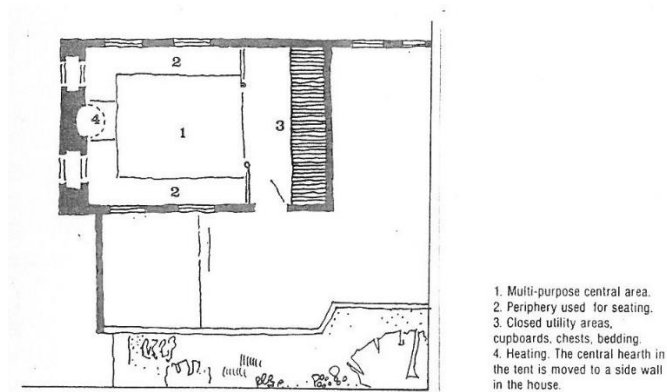


Figure 3.2: Arrangements of Rooms in Turkish House (Küçükerman 1991)

There is a particular spatial sequence can be observed in a Turkish settlement ranging from the most public to semi-public to the most private. Doorways of the individual houses were generally opened to semi-public spaces but the most private spaces were out of reach so can be called the ‘secret paradises’ of families (Imamoglu, 1992).

To maintain privacy on the ground floor, rooms had a few and small windows that could not be opened to the street at the eye level unlike the upper floors that had screened openings with metal grills or wooden frames and shutters. These houses satisfied the needs of the Turkish agricultural lifestyle.

Traditional Turkish family depicts a big family in which grandparents, uncles, aunts, cousins with parents and children live together as members of the same family. Thus, family members is considered as a major element in the house (Ovsyannikov, 1990).

During ottoman period, family structure and habitat was shaped by the Islamic rules resulting in the separation of public and private lives of people that was the consequence of the commitment of a family member to lie in a house as an enclosed area (Michel, 1991).

The room in the Turkish house is also a unit with different functions. Each room can be an equivalent of the house because it is designed like a house. It contained all functions and needs of nucleus groups in the extended family. Generally, the form of a house varies from one place to another and is affected by basic activities of human being such as sleeping, sitting, cooking and eating that are highly culture-bound (Lang, 1987). Different ways of living requires houses to have specific features based on different cultural traditions, with different environmental conditions (Norberg.Schulz, 1980). So, space organization in a house is both dimensional, spatial, and temporary (Lang, 1987).

According to Figure 3.2, each separate room is opened to the spaces that are shared by the other family members including the hall. This design for a room makes it multipurpose. Built-in cupboards (yukluk) or closets (gusulhane) (Figure 3.3) were also found in each room that is why a room was synonymous with the word house (S. H. Eldem, 1969).

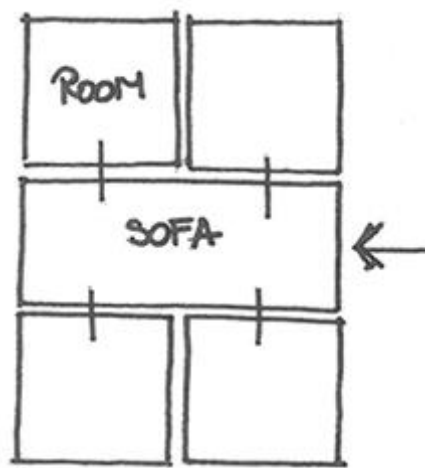


Figure 3.3: Organization of the Sofa and Rooms in Turkish Houses (Sketches by Mohammadzadehafshar, 2015)

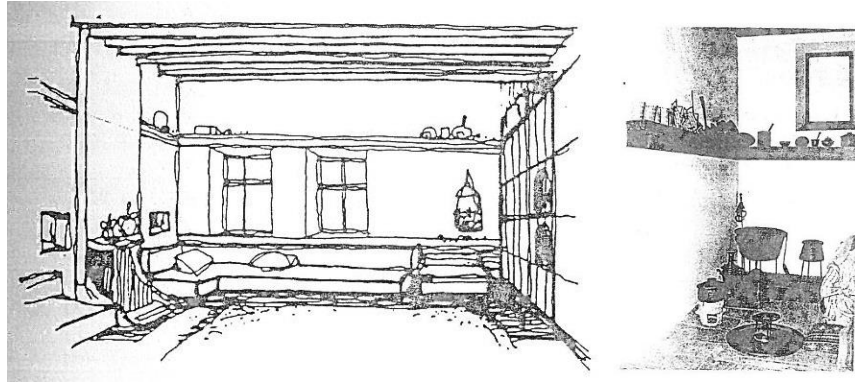


Figure 3.4: A Room of the Turkish House (Küçükerman 1991)

In the family life, father had the personal space usually locate in a place where the room entrance can be observed easily (Unugur, Turgut, 1991). The location in later periods was moved to the middle of the house. Younger children usually had rooms close to the room entrance (Kuban, 1991). The family usually sat on cushions and the surface of the floor was carpeted (Figure 3.3).

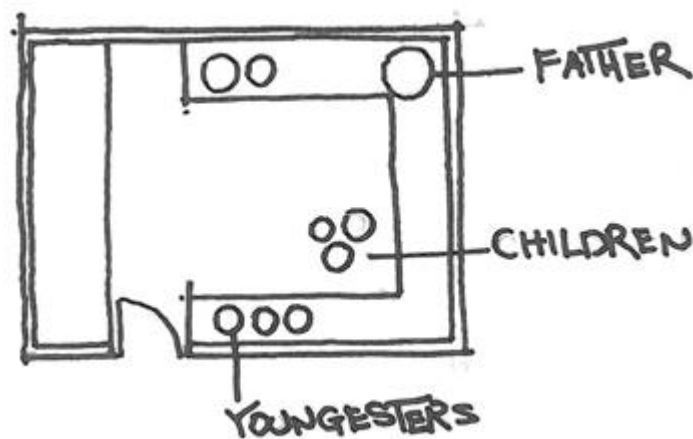


Figure 3.5: The Location of the Fathers' Place in Traditional Turkish House (by Mohammadzadehafshar, 2015)

Sofa that is called by various names in different regions of Anatolia: 'hayat' (life), 'sergah' (display area), 'sergi' (display), 'sayvan' (awning) (Kucukerman, 1991) together with rooms is considered as a core component of Turkish houses. Sofa is a

passage, shared area, that makes relations between rooms possible and it is wide enough serve as a meeting place for the house inhabitants.

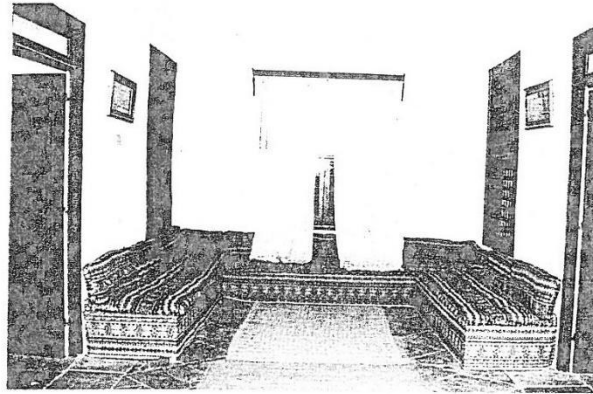


Figure 3.6: Sofa room (Ozay, 1998)

“In the sofa, there are special seating corners as raised platforms which are free from circulation. Sekilik or taht where open to two or three view sides; divan which is a projection in front of the sofa; and eyvan which is recessed form in between the row of rooms are seen especially in the houses with outer hall (sofa). Some sofas provided more than one of these special sitting arrangements while they are rare in the houses with inner hall” (Eldem, 1969).

Located mainly in the courtyard, hamam (bathroom), kitchen, laundry, pantry and store room are considered as Service spaces in the Turkish house; thus, their effect on the plan organization of the house is limited (Eldem, 1969).

The domestic architecture and the architectural elements have studied by several researchers. And the next important period that had effect on domestic architecture of houses in Northern Cyprus was British Period. Hence, the next part of this study will

about characteristics of houses in British Period and evaluate continues and changing characteristics of Ottoman Period in British Period.

3.1.2. British Period (1878-1960)

Since beginning of the colonial period many improvements in transportation and communication networks; administration, education, and health systems; agricultural techniques; urban and rural planning have been achieved (Tozan, Akın, 2009). English rule the island for amount of 80 years. The time could be separated into two architectural durations, earlier English (1878-1929) and later English (1930-1960). Within the primary period of time English discovered this island in all of the approaches. The presenting of English structures to island first of all appeared in administrative buildings. In domestic structures the Ottoman building methods and materials continued utilized particularly in the beginning period of time (Hafizoglu, 2000).

Following 1878, British ruled the island. At the early period (1878-1930), they introduced the pre-existing structures in this area. However, within the next period of time (1930-1960), because of different politics factors, they modified their colonial buildings to the island. Concrete had been utilized for the first time (Fasli, 1997).

At later period, changes observed in the plan types due to improvements in sanitary systems and new regulations. The service parts were included in in the main scheme. Towards the end of the period effects of Modern Movement with new materials became influential. (Hafizoglu, 2000) The living areas developed at second phase of British period have consisted house examples that have one or two floors, located in a garden usually on front and two sides, living spaces directed to street direction with a visual connection and a verandah in front. Additional to single houses, a few multi

storied apartment solutions have first time applied too (Tozan, 2008). These introduced architectural features have strongly influenced Cyprus architecture in the following years.

The impact of the British architecture started to appear in details of the properties such as rock window or even doorjamb and artwork. Later government engineers along with designers began to design homes mixing English Structure and Cypriot Structure. Thus brand new building system introduced by the British to the island and started to use within buildings. For social and cultural causes research of these kinds of houses has enormous crucial to the architectural history of this area (Hafizoglu, 2000).



Figure 3.7: Sample of British House (Ozay, 1998)

3.1.3. Republic of Cyprus Period (1960-1963)

Following the culmination of Cyprus as an independent state in 1959, the Republic of Cyprus was declared in 1960 (Fasli, 1997). In 1963, three years after its foundation, political struggle between the Turks and the Greeks –the two partners of the republic– resulted in political separation of the two communities. Consequently, the Turkish Cypriots have been precluded from the administration of the Republic. (Doratlı, 2000)

Between 1963- 1974, since there was no any rigid physical separation of the two communities, the struggle continued (Doratlı, 2000).

This period has been a continuation of architectural experiences. There are unique modern buildings dating back to Republic Period. As Özay (2005) mentioned one and two-story houses were quite popular.

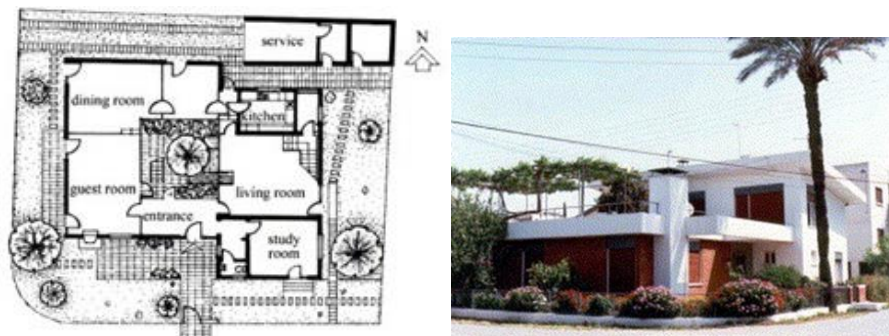


Figure 3.8: House from 1960s (Ozay, 2005)

3.1.4. Turkish Republic of Northern Cyprus (T.R.N.C. Period, 1974-today)

After the military intervention of Turkey, Turkish and Greek people started living separately in two different areas in since 1974. (Tozan, Akın, 2009) When the Turkish population moved from south to the Northern part of the Island the settling in issues were in urgent agenda of the government.

The urgent need to provide houses for the immigrants caused the construction industry to develop quickly. People started to live in the Greeks' houses situated outside of the city walls. (Ozay, 1998)

After peace and intervention of the government in the housing market, a Social Housing was enacted in 1974. The result was a great number of housing unit like apartment types and row houses being built by the government and the private

companies that lacked the qualities of private and semi-private spaces. But the private houses and apartments are constructed by individuals (Fasli, 1997).

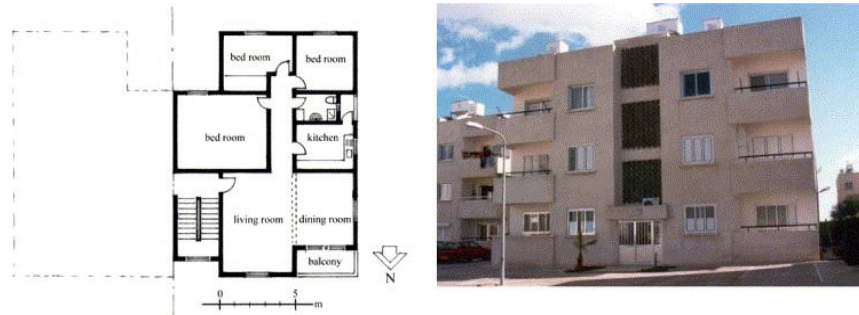


Figure 3.9: Mass Housing Apartment (Ozay, 2005)

This review showed that during all of these historical periods' changes spaces of the domestic architecture in Northern Cyprus.

3.2 Development of Vernacular Architecture, Culture and Living Environments in Northern Cyprus

Vernacular architecture represents the features of rural life at all around the world. It's known as "architecture of the ordinary people" (Ateşin, 2005) that represents the modest agrarian life. There are several studies done related to vernacular architecture in Cyprus. Significance of the vernacular architecture in Cyprus will be basically outlined by the help of those researches.

Settlements have organic structure either compact or spread in farm areas. They have located over flat or sloppy topographies all around the island. Mosques or churches have located usually at the center of the village. Besides religious spaces other public facilities like school, shops, government offices, and coffee-shops have been located as the center of the villages. (Tozan, 2000) Formation of the rural settlements is defined

according to the identification of the relationships between the static patterns of the settlement and the dynamic spatial process of human behavior (Ateşin, 2005).

House in vernacular architecture has been a unit for simple/modest daily life and rural production. House sizes are tightly defined for the basic daily needs and it is suitable for the Mediterranean people who spend most of the year at open and semi open spaces (Tozan, 2000). House is formed as “the physical response of the cultural thought and everyday experiences of the inhabitants” and they have been “pragmatic and utilitarian, developed in response to the habitation needs” (Ateşin, 2005). Tozan (2000) emphasizes that the type of the rural professions such as agriculture of cereal, animal husbandry, local food production had influences on functional organization besides modest living requirements. As mentioned before topography has been a major variable for the formation of the house and the agrarian profession types.

At the study focused on Agrida (Ağırdağ) and Piyi Peristerona (Alaniçi) house solutions have defined as “the two-storied house is a modest building, which can adapt to changes with additional spatial units” (Ateşin, 2005). There has been an interaction between the settlement texture, daily life and professional activities. The settlement characteristics have mainly defined by Ateşin (2005):

“As a result of proximity among the attached houses, high walls are noticed as a spatial definer of the yard. Although high walls are separate the street and yard from each other regarding privacy needs, in some cases, the building itself takes this role as a definer of the public and private domains’ segregation.”

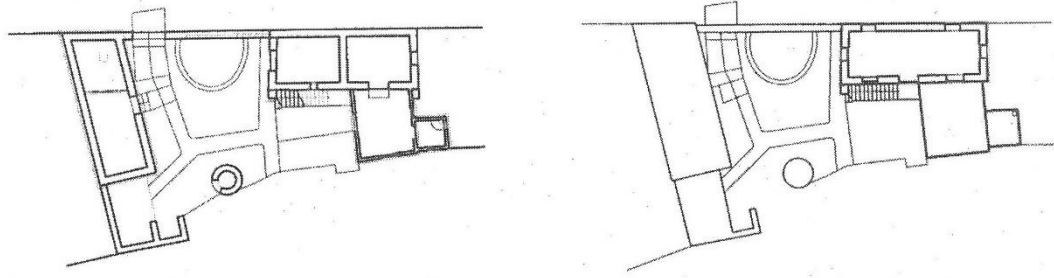


Figure 3.10: Typical Vernacular House in Agrida (Ağırdağ) (Ateşin, 2005)

Within its special contextual characteristics vernacular house is defined as:

“In the rural house Agrida, the living unit is the main spatial element. It is comparatively more elaborated and includes the valuable furniture. When the living unit is on the ground floor, it is spatially segregated by means of an arch, which is a structural element. The use of this arch led to the development of two sub-spaces that were generally utilized for the daily living and sleeping activities. In fact, private living units were generally on the upper floors. In the house where the upper floor is completely reserved for daily living the ground floor is usually utilized as storage for agricultural products and equipment with comparatively limited openings or as animal shelter for oxen with maximum exposure to the outside. On the other hand, straw storage is generally located in the yard at a distance from the main living unit.” (Ateşin, 2005)

In Northern Cyprus similar other developing countries the processes of urban dynamics have changed the social, cultural and morphological formation of spatial organization both in the city scale and the village scale. (Oktay, 2002) When look at new housing developments, climate conditions of the island do not seem to be

considered at all, not only in the orientation of the dwelling units, but also in the formation and arrangement of residential buildings. (Oktay, 2001) The villages were flooded with houses that looked very different from vernacular dwellings. All functions combined together in center of the yard (Kürüm, 2012).

3.2.1. Yeniboğaziçi as a Village under Famagusta's Changing Dynamics

Yeniboğaziçi village, is located nearby the Salamis antique city dating back to the Colonial Roman period (1st century AD), between Karpaz peninsula and the city of Gazimagusa (Famagusta).

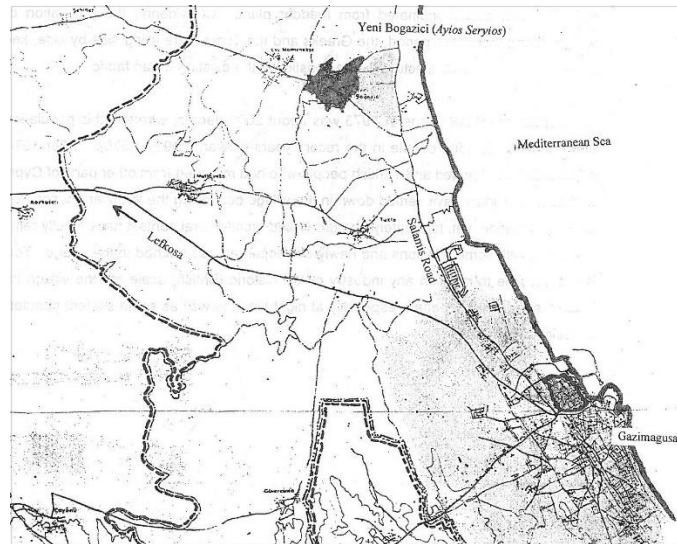


Figure 3.11: The Location of Yeniboğaziçi Village (Önal, 1996)

Based on the records, the first establishment of Yeniboğaziçi village has been dated back to Byzantine period (Klerides, 1961). The characteristics of the village has been evaluated in the same way by the Lusignans in the following centuries.

Yeniboğaziçi village carry out cultural personality in many feelings. The effect of Ottoman period and British period cultures can be seen at urban and actually houses

whole the village. Actually should be say that the essential characteristics of the village due to cultures have been changed in organization. (Önal & Dağlı, 1996)



Figure 3.12: Yeniboğaziçi Village (By Mohammadzadehafshar, 2015)

The evaluation of characteristics of houses in Ottoman and British period by Önal and Dağlı;

“The plan type (either one or two storeys) constitutes a sofa which is based entirely on the hot climate of Cyprus. The sofa and rooms placed on either side of the sofa constitute the plan type of the houses. Generally the house plans have three essential parts: a rear courtyard, a main unit which has a sofa on the central axis and the lateral living areas around it, and a triple arcade facing the south at the front or back of the main unit. Going up to the second floor, one will find out that, only some part of the ground floor is extended to the second floor of the house. No decoration is used within and out of the buildings” (Önal, 1996).

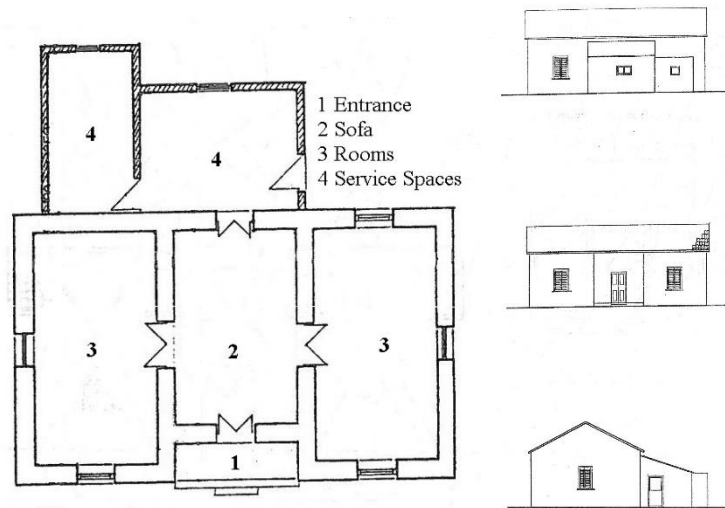


Figure 3.13: Typical Vernacular House in Yeniboğaziçi Village (Önal, 1996)

This review showed that during all of these historical periods' changes spaces of the domestic architecture in Northern Cyprus. Hence, by the help of these information about spaces in domestic architecture in Northern Cyprus, the next chapter will be analysis and evaluate case studies in Yeniboğaziçi village at Famagusta in Northern Cyprus.

Chapter 4

ANALYSIS OF LIVING ROOM AND KITCHEN SPACES AT YENİBOĞAZIÇI VILLAGE

4.1 Importance of Living Room and Kitchen Spaces

Living spaces are as the most used space and kitchens are as the most specialized space within others in home environment. Living space where that family spend most of their time and it is the space for; forgather, relaxing, chatting with together, watching TV, and entertainment. Kitchen is the space for working that define the heart of the house. Besides these activities that happening in each of these spaces and the important role that spaces have; the relationship between these two spaces with together and outdoor is so important. So in this chapter the relationship and hierarchy are going to be analyzed specially between living room and kitchen spaces with together and outdoor. It is believed that by examining various living room and kitchen spaces, the significance of the hierarchy and relationship between tow these spaces and with outdoor are going to be determined.

4.2 Method of Analysis

As a case study, the research focuses on randomly selected house cases from various building dates in Yeniboğaziçi village. It is aimed to analyze living room and kitchen spaces of those houses which have built in different times and requirement in order to understand interiors of living. Studies were done at living room and kitchen spaces covers; observations, sketches and photograph of houses. The sample of living room

and kitchen spaces were evaluated according to their plan layouts, space organization, walls, openings, lighting and color, and furniture and fixtures.

4.2.1 Evaluation of Selected Living Room and Kitchen Interiors

Case studies are determined by houses types that included three types of houses; five contemporary houses, five single new houses and five apartments. As a case, researcher selected houses from Yeniboğaziçi in Famagusta in Northern Cyprus.

The aim of selecting case studies in this study is to analyze changes and continuities in domestic architecture and spatial organization in relation to interior characteristics and elements of living room and kitchen spaces.

Observation is developed for analysis of domestic architecture and spatial organization of living room and kitchen spaces.

4.3 Analysis of Living Room and Kitchen Spaces

Observation is developed for analysis living room and kitchen spaces. Living room and kitchen spaces are selected from 15 houses – three different plans each consisting of five living spaces that each house is analyzed in a table. They are analyzed by the help of photos, plan and sketches.

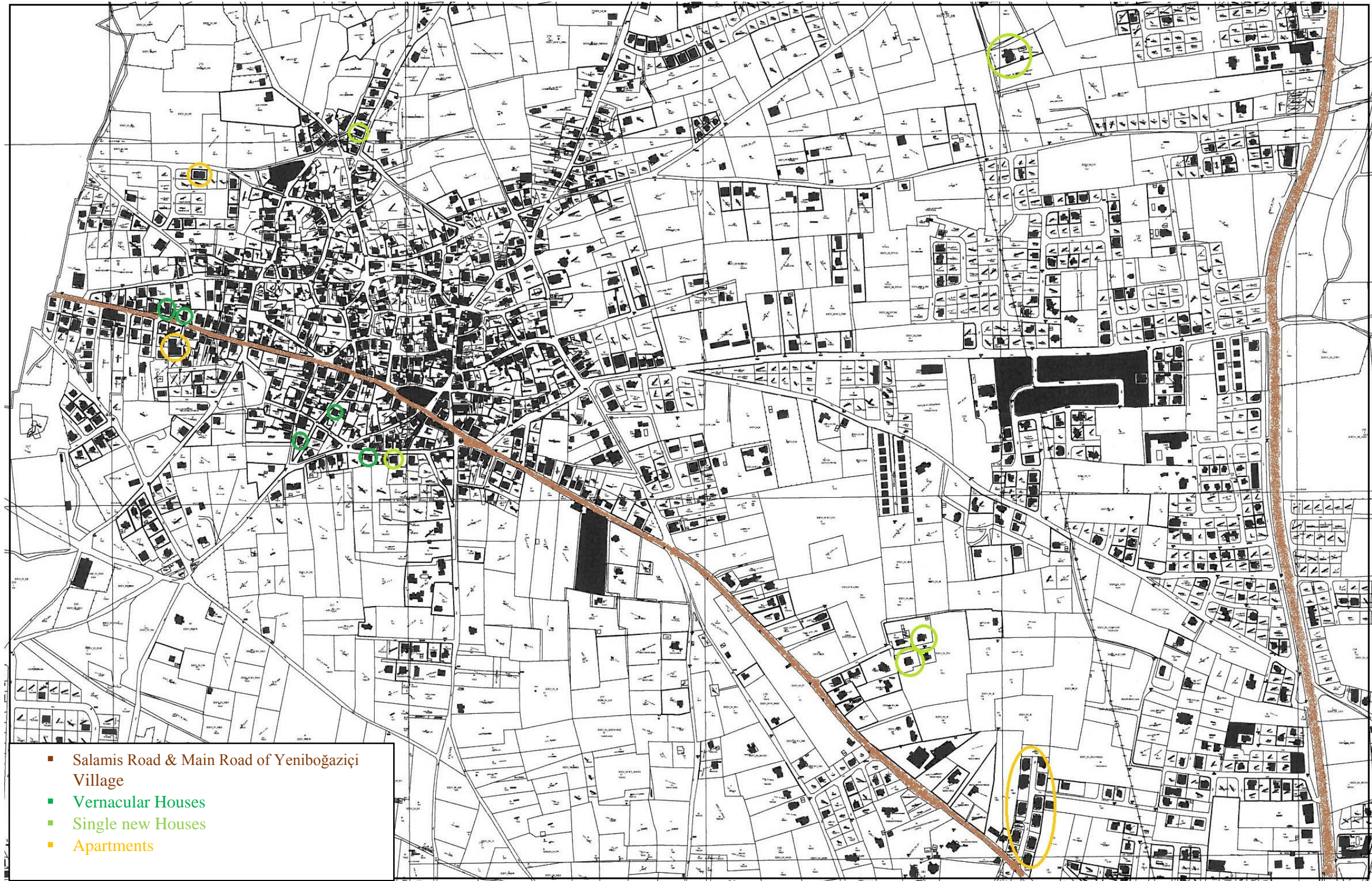


Figure 4.1: Site Plan of Yeniboğaziçi Village

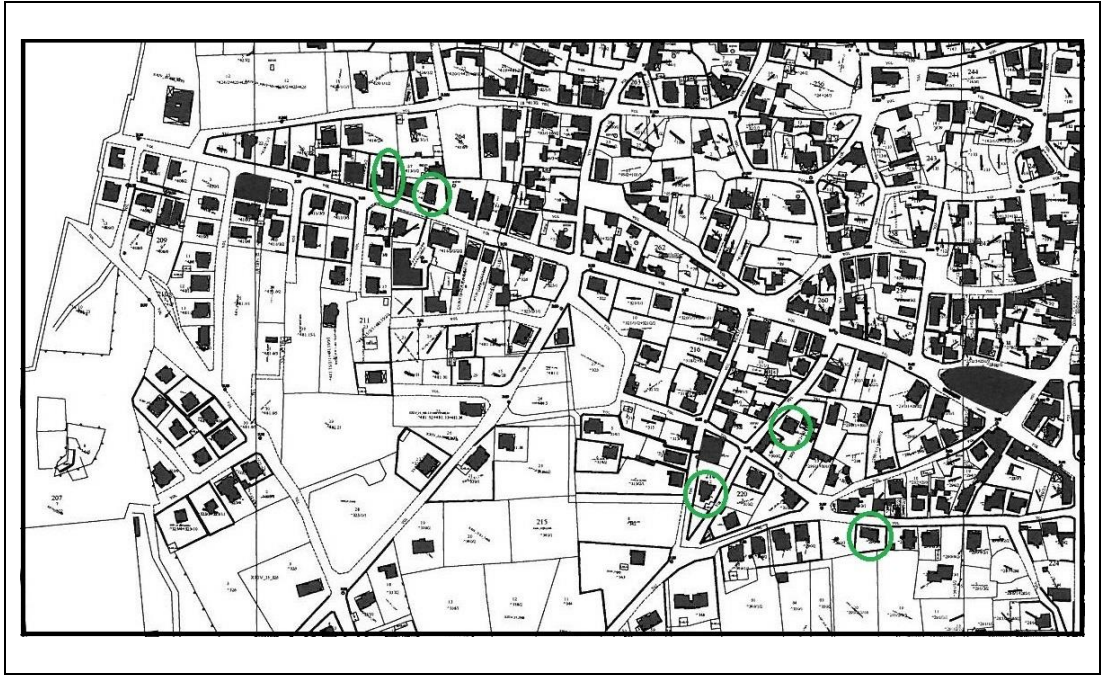


Figure 4.2: Contemporary Houses in Yeniboğaziçi Village

Evaluation of the Living Room and Kitchen Interiors in Contemporary Houses in Yeniboğaziçi Village

Five of living rooms and kitchen spaces in contemporary architecture analyzed for evaluation and help to give clue about characteristics and elements of them.

Pursuant to make mention above, five of houses chosen from contemporary houses. Living rooms in these houses generally opens to the entry hall and this part (entry hall), is the relationship between living room and exterior spaces either open or semi open (balconies). Rooms placed on either three side of the entry hall. Actually entry hall is arranged for daily use-seating area. This creates ease relations with the woman and the other women's neighbor. And living room it can be said that is organized for the guests.

The service rooms, including kitchen spaces, combined to the house and arranged in the back (or in the last part of the house). Kitchen have contact with two parts of the house;

- A long corridor that have mention with other rooms and actually the living room.
- And another one is a private door that make relation between the kitchens with outdoor of the house that is opens to the open (back of the courtyard) or semi-open (balconies) spaces.

Main elements of living rooms and kitchen spaces in contemporary architecture are;

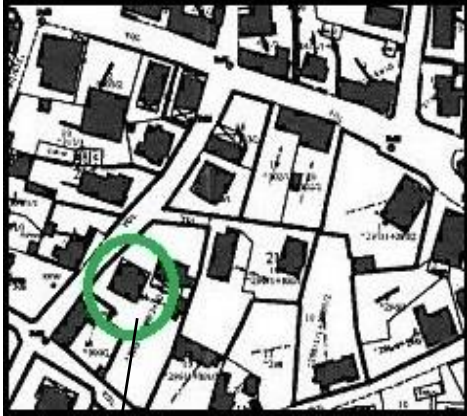
- Each space separated by walls from other spaces (they do not have view together). For example, when person seat in entry hall or living room, does not have view to kitchen or other places. Main doors' materials are mostly, wood and sometimes metal, that these are decorated with vertical glasses in next to them. And the interior doors are wood without any specific decoration. Living spaces' window openings in these

type of houses are designed in large size that covered with curtain and they are made with metal material.

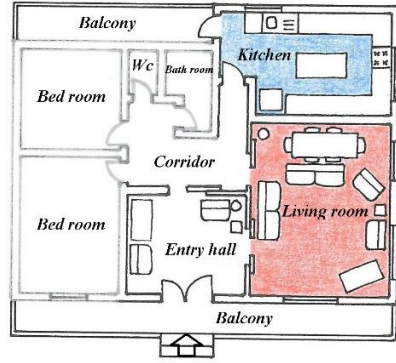
- Living spaces designed by moveable furniture that chosen according to numbers of family members and organized around television. While look at the design of the living room and kitchen space, it can be observed something such as, picture family frame that covered all a wall or most of walls and also decorative fixtures on the wall and on the different type of tables without clarity. And wardrobe is used less frequently. It is possible to observe the fixed elements, such as wardrobes that are fixed onto the wall and cupboards at the kitchen. Carpet and kilim are the floor covering that can be seen in living spaces of this type of houses.

- Natural light is the main source of lighting during the day and the luminous intensity of natural light control by shade screen. Meanwhile for lighting at night use from lamp (light bulb). In interior spaces in these type of houses, are painted with light colors that also climatic and strong Mediterranean sun have an effect on this type of choose from colors.

Table 4.1: Spatial Organization and Architectural Elements of Living room and Kitchen Spaces, Inventory No: 1.1



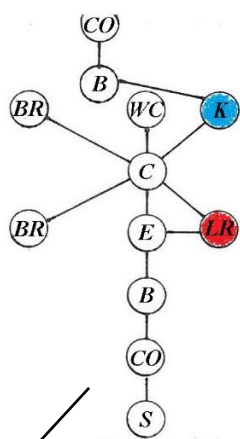
Town: **FAMAGUSTA**
 District: **YENİBOĞAZIÇI**
 Street: Shehit Bekir Etem Sokagı
 Date of Construction: Around 1975
 Number of Floors: 1



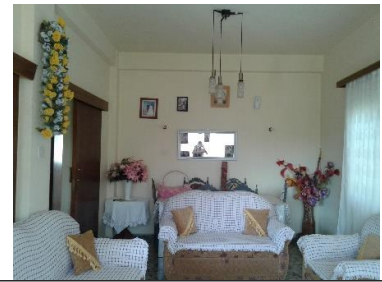
After passing from the street (public place), received to a small garden that is designed in front of the balcony. Door in balcony open to a square shapes' entry hall (public space) that is connected with two doors to two various space; living room and a corridor. Living room has straight relation to both of entry hall and the corridor. But for arriving to kitchen from entry hall should pass the corridor.

Space Organization:
S: Street
CO: Courtyard
B: Balcony
E: Entrance Hall
LR: Living Room
BR: Bed Room
C: Corridor
K: Kitchen
WC: WC & Bath Room

Living room design by rectangular shape. On two of living room's walls designed by three window, one window open to front of the house and has view to courtyard and street and by other two window has view to back courtyard. One wall of living room by two doors has connection with entry hall and corridor. **Kitchen** by rectangular shape have view point to back courtyard and open to back courtyard and the corridor.



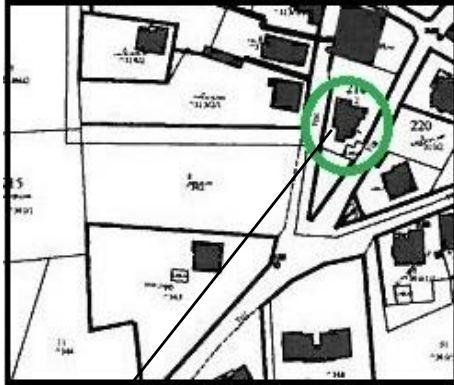
Living room is arranged in front of the house near an entry hall. But instead of living room, kitchen located on back of the house and back of the living room.



Use from window for day lighting and simple lamp' ceiling.
 Use movable furniture according to number of family members. Arranged around TV. Use dining table back of the furniture. On the walls use frames. Use artificial flower around the space. Covering furniture with traditional covers.

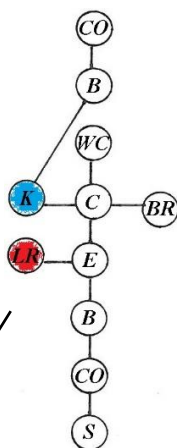


Table 4.2: Spatial Organization and Architectural Elements of Living room and Kitchen Spaces, Inventory No: 1.2

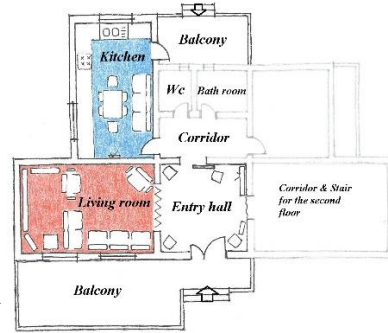


Town: **FAMAGUSTA**
 District: **YENİBOĞAZIÇI**
 Street: **Şehit Hüseyin Hamza Sokakı**
 Date of Construction: **Around 1960**
 Number of Floors: **2**

Space Organization:
S: Street
CO: Courtyard
B: Balcony
E: Entrance Hall
LR: Living Room
BR: Bed Room
C: Corridor
K: Kitchen
WC: WC & Bath Room



Living room is located in front of the house near an entry hall. Kitchen put on back of the house and back of the living room.



Pass the street, small garden, and balcony and then received to entry hall. That is connected with three doors to living room, a corridor and stairs. Living room has straight relation to entry hall. But for arriving to kitchen from entry hall should pass the corridor. Corridor is connection between living room and kitchen.

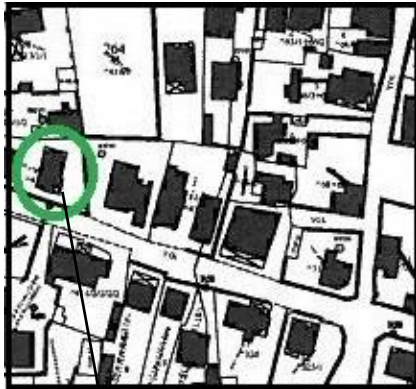
One living room's wall designed by two window open to front of the house and has view to courtyard and street. One wall of living room by a door has connection with entry hall. Kitchen has view point to back courtyard and open to back courtyard and the corridor.



Use from window for day lighting and luster's ceiling.
 Use movable furniture according to number of family members. On the walls and cupboards use lots of frames. Use artificial flower around the space.
 In kitchen use cupboards on the wall and put frames, fixtures. Dining table in kitchen for daily life.

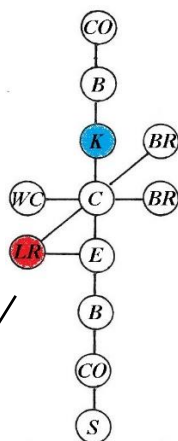


Table 4.3: Spatial Organization and Architectural Elements of Living room and Kitchen Spaces, Inventory No: 1.3

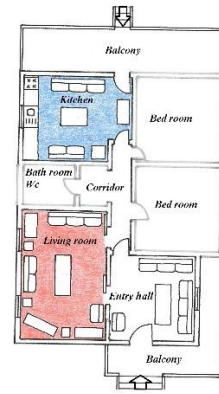


Town: **FAMAGUSTA**
 District: **YENİBOĞAZIÇI**
 Street: Barbaros Hayrettin Sokagı
 Date of Construction: Around 1960
 Number of Floors: 1

Space Organization:
S: Street
CO: Courtyard
B: Balcony
E: Entrance Hall
LR: Living Room
BR: Bed Room
C: Corridor
K: Kitchen
WC: WC & Bath Room



Living room is located in front of the house near an entry hall. Kitchen put on back of the house.



Pass the street, small garden, and balcony and then received to entry hall. That is connected with two doors to living room, and corridor. Living room has straight relation to entry hall. But for arriving to kitchen from entry hall should pass the corridor. Corridor is connection between living room and kitchen.

Two living room's wall designed by two window. One of them open to front of the house and has view to courtyard and street and another one open to back courtyard. One wall of living room by a door has connection with entry hall. Kitchen has view point to back courtyard and open to back courtyard and the corridor.



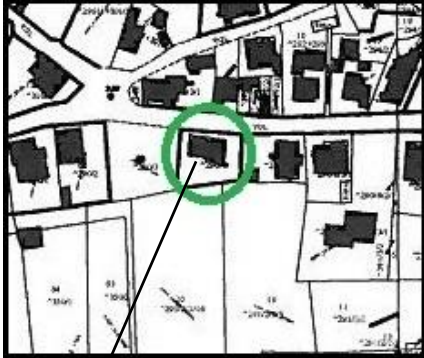
Use from window for day lighting and simple lamps' ceiling.

Use movable furniture according to number of family members. That covered with traditional covers. On the walls and cupboards use lots of frames. Use artificial flower around the space.

In kitchen use cupboards on the wall. Dining table in kitchen for daily life.

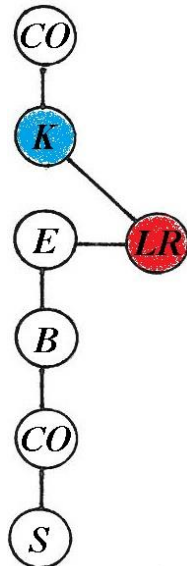


Table 4.4: Spatial Organization and Architectural Elements of Living room and Kitchen Spaces, Inventory No: 1.4

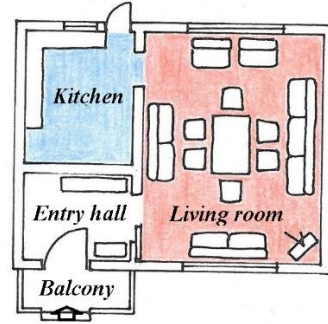


Town: **FAMAGUSTA**
 District: **YENİBOĞAZIÇI**
 Street: Shehit Bekir Etem Sokagi
 Date of Construction: Around 1975
 Number of Floors: 1

Space Organization:
S: Street
CO: Courtyard
B: Balcony
E: Entrance Hall
LR: Living Room
BR: Bed Room
C: Corridor
K: Kitchen
WC: WC & Bath Room



Living room is located in front of the house near an entry hall. Kitchen put on back of the house.



Pass the street, small garden, and balcony and then received to entry hall. That is connected a door to living room. Living room has straight relation to entry hall and kitchen. But for arriving to kitchen from entry hall should pass the living room.

Two living room's wall designed by two window. One of them open to front of the house and has view to courtyard and street and another one open to back courtyard. One wall of living room by a door has connection with entry hall. Kitchen has view point to back courtyard and open to back courtyard and the corridor.



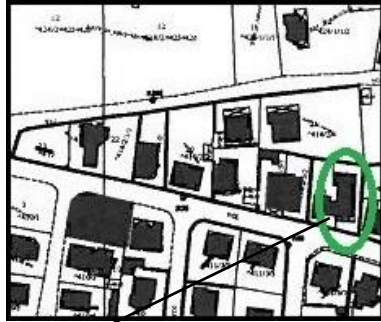
Use from window for day lighting and simple lamps' ceiling.

Use movable furniture according to number of family members. Don not use any special fixture. Dining table located center of the living room.

In kitchen use cupboards on the wall.

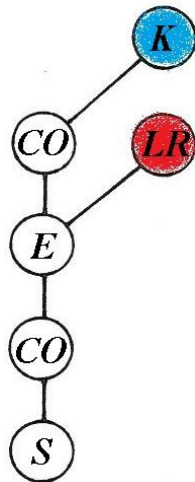


Table 4.5: Spatial Organization and Architectural Elements of Living room and Kitchen Spaces, Inventory No: 1.5

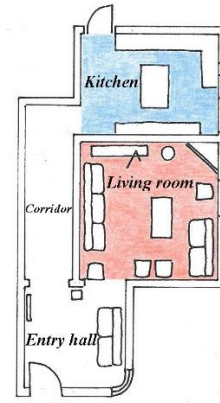


Town: **FAMAGUSTA**
 District: **YENİBOĞAZIÇI**
 Street: Barbaros Hayrettin Sokagı
 Date of Construction: Around 1980
 Number of Floors: 2

Space Organization:
S: Street
CO: Courtyard
B: Balcony
E: Entrance Hall
LR: Living Room
BR: Bed Room
C: Corridor
K: Kitchen
WC: WC & Bath Room



Living room is located between entry hall and the kitchen. Kitchen put on back of the house.



Pass the street, small garden, and then received to entry hall. That is connected to living room. Living room has straight relation to entry hall. But for arriving to kitchen from entry hall should pass a corridor.

One living room's wall designed by a window. That open to front of the house and has view to courtyard and street. One wall of living room by an opening has connection with entry hall. Kitchen has view point to back courtyard and open to back courtyard and the corridor.



Use from window for day lighting and lusters' ceiling.
 Use movable furniture according to number of family members around TV. Two walls decorated with frames and fixtures. Dining table located center of the kitchen. Use frames and fixtures on the cupboards.
 In kitchen use cupboards on the wall.





Figure 4.3: Single New Houses in Yeniboğaziçi Village

Evaluation of the Living Room and Kitchen Interiors in Single New Houses in Yeniboğaziçi Village

Other five of living spaces' evaluation about characteristics and elements of them analyzed in single new houses type that constructed in Yeniboğaziçi village.

Living rooms in these type of houses generally opens to the corridor or directly to the semi-open (balconies) and open (courtyard) space (exterior area). It cannot be see any specific area that can call entry hall. Rooms placed on either side of the corridor. Generally, there are two type of organizational groups of living room in this type of houses;

- The first one arranged for daily use-seating area. This creates ease relations with the family that furniture in this space organized around television. The other one is organized for the guests.

The service rooms, especially kitchen spaces, combined with the other places in the house and arranged in the back (or in the last part of the house). Kitchen have contact with two parts of the house;

- It has connection with living room without any boundaries or with a corridor connect to other rooms and actually the living room.
- Kitchen has a private door that make relation between the kitchens with outdoor of the house that is opens to the open (back of the courtyard) or semi-open (balconies) spaces.

Main elements of living rooms and kitchen spaces in single new houses are;

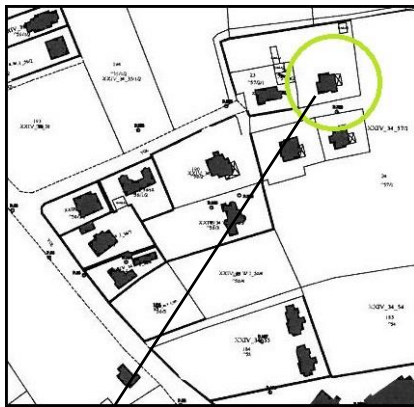
- Walls are the separation between areas and doors that placed in walls are the connection between them. So, with closing door, it is not possible to have view of another place. Main doors in these type of houses are wood that decorated with vertical

glasses in next to them. And the interior doors are mix of wood with glasses. Living spaces' window openings in these type of houses are designed in large size that they make relations between inside and outside. Living rooms and kitchens have view to outside (street and back yard) by the help of windows that covered with curtain and they are made with metal material.

- In similarity with the contemporary houses, living spaces designed by moveable furniture that chosen according to numbers of family members and organized around television. With observing design of the living room and kitchen space, there is no particular decorations on the walls. For instance, may be just a frame placed on the center of a wall of the living room. Actually, the frame is not the photo of the family. It can be observed decorative fixtures on the tables' furniture. It is possible to observe the fixed elements, such as wardrobes that are fixed onto the wall and cupboards at the kitchen. The floor covering are generally formed by marble, mosaic, stone or other base materials instead of carpets, kilim rugs and the others. Also, carpet and kilim just use for decoration, not for covering the floor.

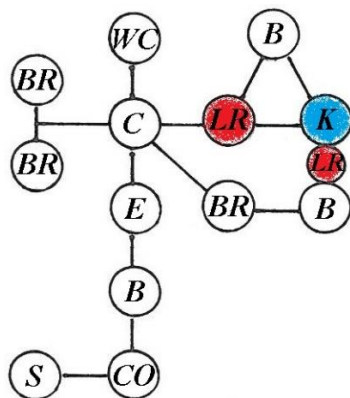
- About lighting, these type of houses exactly have same situation with vernacular contemporary houses. In during a day, use from natural light and control the shadow by shade screen. And for lighting in night use from lamp (light bulb). The mostly color that use in these type of houses is white. But, now a days, by according to the effect of tendency in decorating and designing the house, it can be seen another colors in some parts of the house.

Table 4.6: Spatial Organization and Architectural Elements of Living room and Kitchen Spaces, Inventory No: 2.1

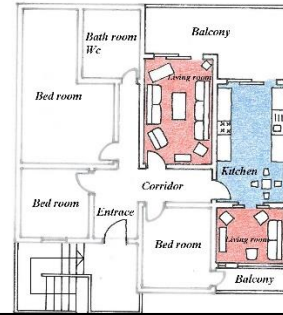


Town: **FAMAGUSTA**
 District: **YENİBOĞAZIÇI**
 Street: Gelincik Sokagi
 Date of Construction: Around 2000
 Number of Floors: 2

Space Organization:
S: Street
CO: Courtyard
B: Balcony
E: Entrance Hall
LR: Living Room
BR: Bed Room
C: Corridor
K: Kitchen
WC: WC & Bath Room



There are two living room that one of them connected with a corridor to entry hall and the other is located near the kitchen. Kitchen put on back of the house.



Pass the street, courtyard, and stairs and then received to entry hall. That is connected to a corridor. Living room has straight relation to corridor and then to entry hall. For arriving to kitchen from entry hall should pass a corridor too.

Two living room's walls that is near the kitchen designed by a window. That open to courtyard. One wall of living room by an opening has connection with kitchen. Kitchen has view point to back courtyard and open to a balcony and the corridor.

Another living room on a wall has view back courtyard and open to balcony.

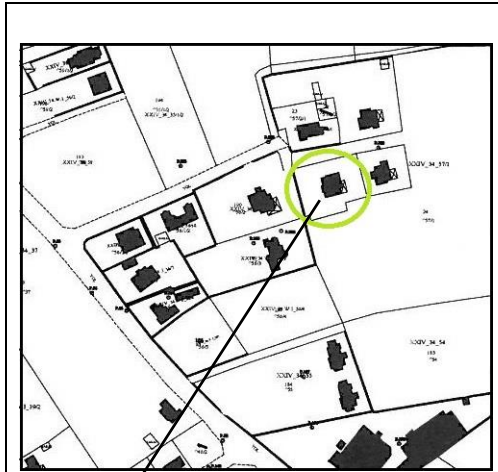


Use from window for day lighting and lusters' ceiling.

Use movable furniture according to number of family members around TV. There are not special fixtures. Use cupboards in kitchen.

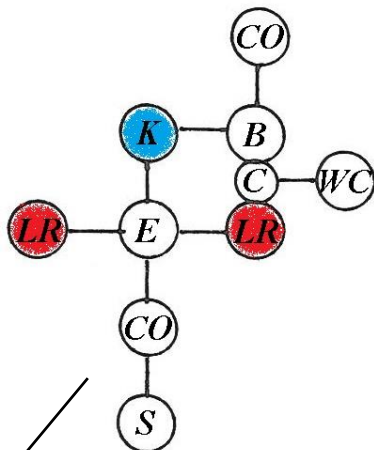


Table 4.7: Spatial Organization and Architectural Elements of Living room and Kitchen Spaces, Inventory No: 2.2

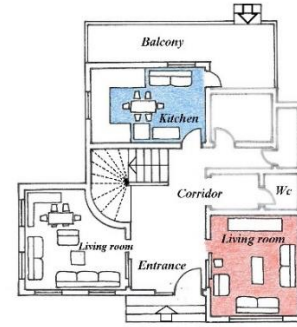


Town: **FAMAGUSTA**
 District: **YENİBOĞAZIÇI**
 Street: Gelincik Sokakı
 Date of Construction: Around 2000
 Number of Floors: 2

Space Organization:
S: Street
CO: Courtyard
B: Balcony
E: Entrance Hall
LR: Living Room
BR: Bed Room
C: Corridor
K: Kitchen
WC: WC & Bath Room



There are two living room that they are located near entry hall (left and right hand). Kitchen put on back of the house.



Pass the street, courtyard, and then received to entry hall. Living rooms has straight relation to entry hall. And kitchen has straight relation with entry hall.

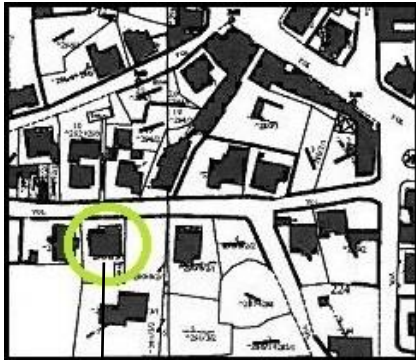
Both living room's walls designed by a windows. That open to courtyard and another view is street. Both walls of living rooms by doors have connection entry hall. Kitchen has view point to back courtyard and open to a balcony.



Use from window for day lighting and lusters' ceiling.
 Use movable furniture in both living rooms. One of them located round the TV for daily life. That there is not special fixtures on it just a big frame on the wall. And another living room designed for when have guests.
 Use cupboards in kitchen.

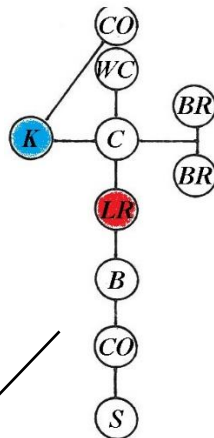


Table 4.8: Spatial Organization and Architectural Elements of Living room and Kitchen Spaces, Inventory No: 2.3

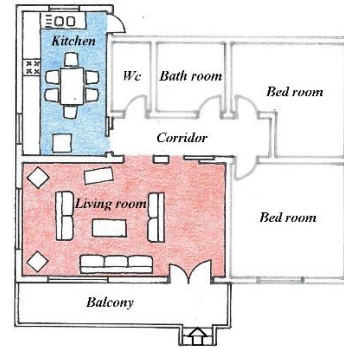


Town: **FAMAGUSTA**
 District: **YENİBOĞAZIÇI**
 Street: **Şehit Bekir Etem Sokakı**
 Date of Construction: **Around 1995**
 Number of Floors: **1**

Space Organization:
S: Street
CO: Courtyard
B: Balcony
E: Entrance Hall
LR: Living Room
BR: Bed Room
C: Corridor
K: Kitchen
WC: WC & Bath Room



Living room is located in front of the house and near the entry hall. Kitchen put on back of the house.



Pass the street, courtyard, and then received to entry hall. Living room has straight relation to entry hall. And kitchen has relation with corridor.

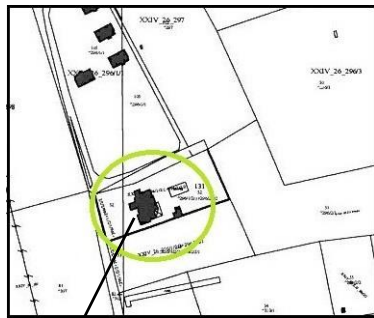
Two living room's walls designed by window. That one of them open to front of the house and has view to courtyard and street and another one has view to back courtyard. One wall of living room by an opening has connection with corridor that is a relation between living room and kitchen. Kitchen has view point to back courtyard and open to back courtyard and the corridor.



Use from window for day lighting and lusters' ceiling.
 Use movable furniture in living room. That located round the TV. Use a little of fixtures on the walls. And use from traditional covers on furniture.
 Use cupboards and dining table in kitchen.

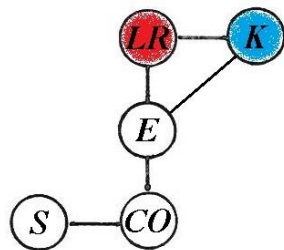


Table 4.9: Spatial Organization and Architectural Elements of Living room and Kitchen Spaces, Inventory No: 2.4

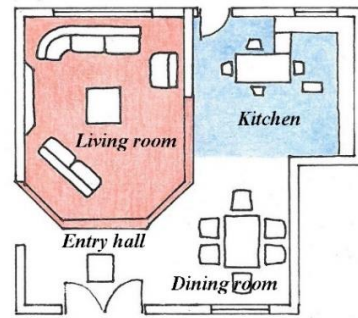


Town: **FAMAGUSTA**
 District: **YENİBOĞAZIÇI**
 Street: _
 Date of Construction: Around 2008
 Number of Floors: 2

Space Organization:
S: Street
CO: Courtyard
B: Balcony
E: Entrance Hall
LR: Living Room
BR: Bed Room
C: Corridor
K: Kitchen
WC: WC & Bath Room



Living room is located in front of the house and near the entry hall.
 Kitchen put near the living room.



Pass the street, courtyard, and then received to entry hall.
 Living room has straight relation to entry hall and kitchen.

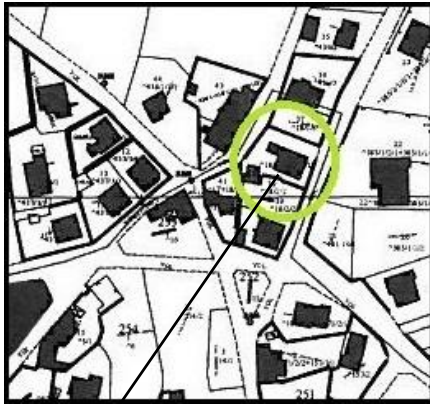
One living room's wall designed by window. That open to back courtyard. From one side, living room has straight relation with kitchen. Kitchen has view point to back courtyard and open to back courtyard.



Use from window for day lighting and lusters' ceiling.
 Use movable furniture in living room. That located round the TV. Use a little of fixtures on the walls and cupboards.
 Use cupboards and dining table in kitchen.

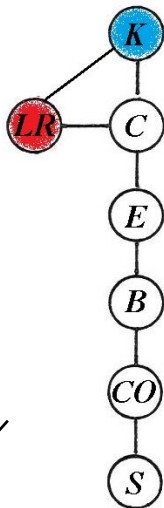


Table 4.10: Spatial Organization and Architectural Elements of Living room and Kitchen Spaces, Inventory No: 2.5

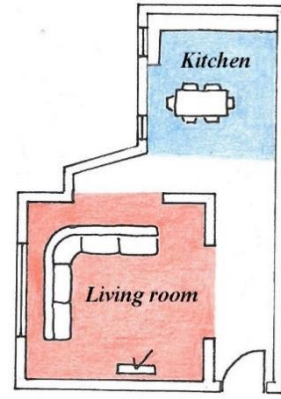


Town: **FAMAGUSTA**
 District: **YENİBOĞAZIÇI**
 Street: _
 Date of Construction: Around 2000
 Number of Floors: 2

Space Organization:
S: Street
CO: Courtyard
B: Balcony
E: Entrance Hall
LR: Living Room
BR: Bed Room
C: Corridor
K: Kitchen
WC: WC & Bath Room



Living room is located in front of the house and near the entry hall and corridor. Kitchen put back of the living room.



Pass the street, courtyard, and then received to entry hall and corridor that has relation with living room and kitchen. Living room has straight relation to kitchen.

One living room's wall designed by window. That open to back courtyard and street views'. From one side, living room has straight relation with kitchen. Kitchen has view point to back courtyard and open to back courtyard.



Use from window for day lighting and lusters' ceiling.

Use movable furniture in living room. That located round the TV. Use a little of fixtures on the walls and cupboards.

The separation between kitchen and living room is just a dining table. Use cupboards in kitchen.



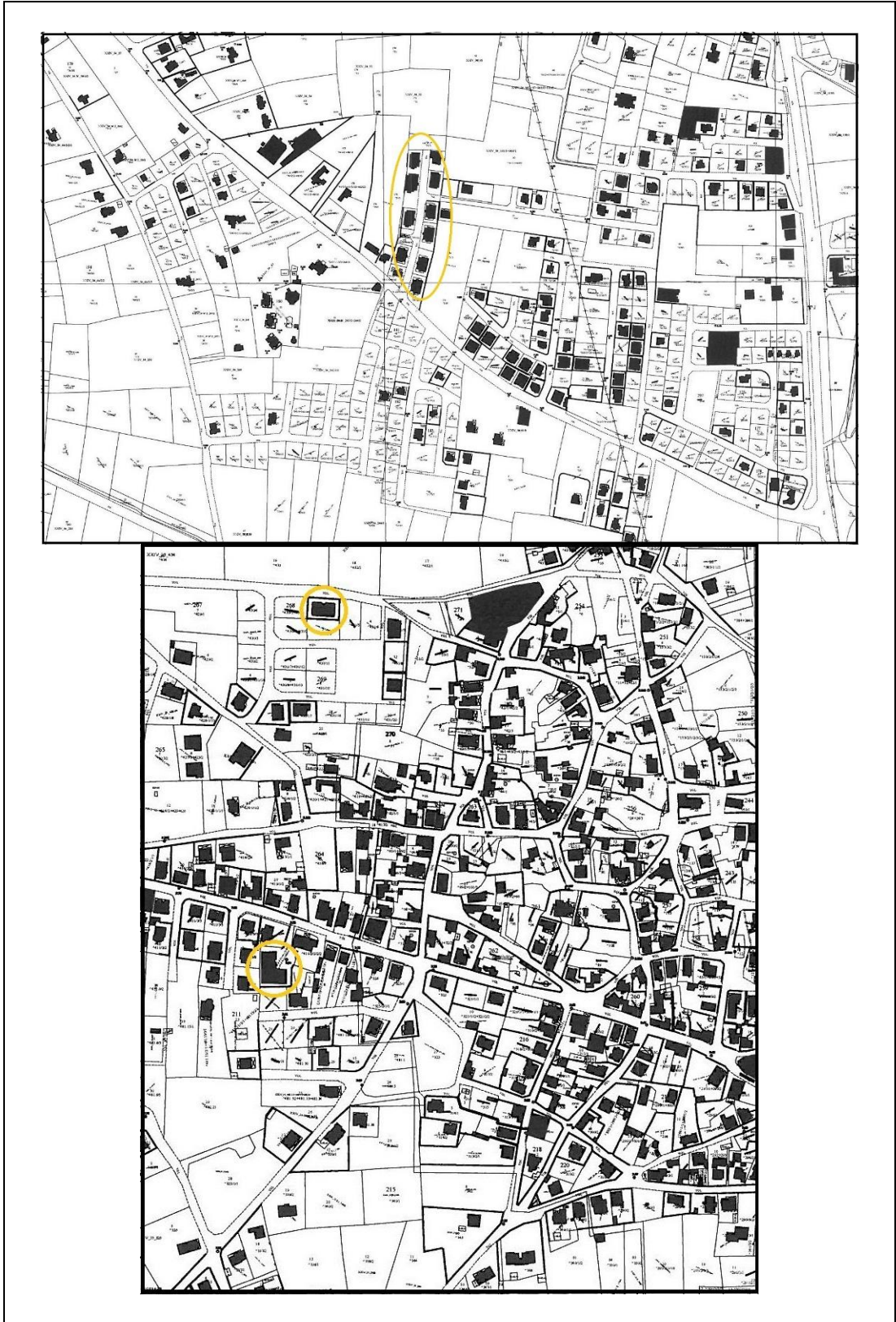


Figure 4.4: Apartments in Yeniboğaziçi Village

Evaluation of the Living Room and Kitchen Interiors in Apartments in

Yeniboğaziçi Village

Living rooms and kitchen spaces of apartments are another type that analyzed in this study that constructed in Yeniboğaziçi village.

Living rooms in this type mostly open to the semi-private (corridor) or directly to the semi-open (stairs) and then open (street) space (exterior area). It cannot be see any specific area that can call entry hall. In these cases, rooms placed on either side of the corridor or exactly side together. This type of house generally, included one living room that is used both of daily use-seating and for the guests.

Kitchen spaces, combined with the other places in the house and mostly with living rooms. Mostly, there is no separation with use of walls between kitchens with other places. Also, they have contact with a balcony.

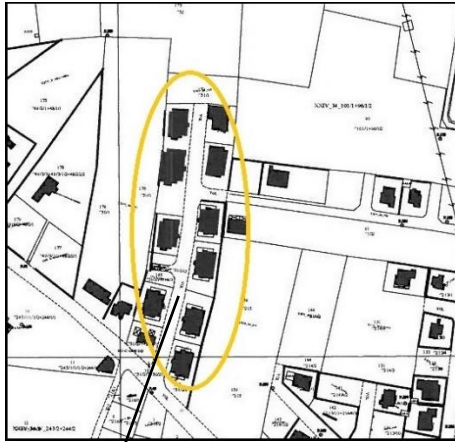
Main elements of living rooms and kitchen spaces in these cases are;

- In most of these type of cases it cannot be seen that walls be the separation between living room and kitchen space. Mostly, living room and kitchen have directly connection with together. Main doors and interior doors, both of them, in these type are wood that decorated without any specific characteristic. The windows in these type of houses are shown similarities in size and material with other type of cases in this study (contemporary and single new houses) that make view point to the outside.
- Furniture that they are movable elements organized around television and chosen according to number of family members. According to observe of the living room and kitchen space, there is no particular decorations on the walls same as in single new houses. One frame constructed a focal point on one of walls in the living room. And

also seen some decorative fixtures on the tables' furniture. It can be seen the fixed elements, for instance, wardrobes that are fixed onto the wall and cupboards at the kitchen. The floor covering as same on single new houses are generally formed by marble, mosaic, stone or other base materials instead of carpets, kilim rugs and the others. Also, carpet and kilim just use for decoration, not for covering the floor.

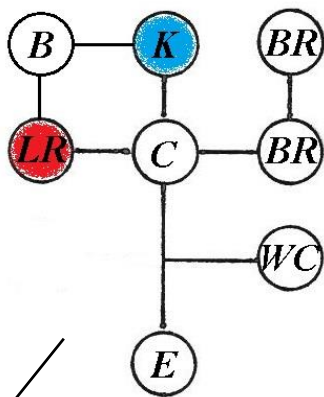
- For day lighting references in this type of case, during the use from natural light that shadow is control with shade screen, exactly like other type of cases in this study. And for lighting references in night use from lamp (light bulb). Now a days, as mentioned in previous part of this study (evaluation of single new houses), by according to the effect of tendency in decorating and designing the house, it can be seen another colors besides of white color in some parts of the house. And use from wall paper in some part of house too.

Table 4.11: Spatial Organization and Architectural Elements of Living room and Kitchen Spaces, Inventory No: 3.1

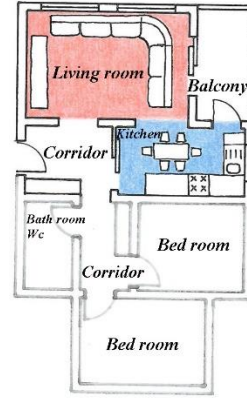


Town: **FAMAGUSTA**
 District: **YENİBOĞAZIÇI**
 Street: Çiftçioglu Sokak
 Date of Construction: Around 2010
 Number of Floors: 6

Space Organization:
S: Street
CO: Courtyard
B: Balcony
E: Entrance Hall
LR: Living Room
BR: Bed Room
C: Corridor
K: Kitchen
WC: WC & Bath Room



Living room is located near a corridor that has straight relation with entrance. Kitchen put back of the living room.



Pass the street, stairs and then received to entrance that connected straight with corridor. That has relation with living room and kitchen. Living room has straight relation to kitchen.

One living room's wall designed by window. That open to street views'. From two sides, living room has straight relation with corridor and kitchen. And actually has relation with balcony. Kitchen has view point to back of the apartment and open to balcony.



Use from window for day lighting and lusters' ceiling.

Use movable furniture in living room. That located round the TV. Use a little of fixtures on the walls and cupboards.

There is no separation between kitchen and living room. Use dining table and cupboards in kitchen.

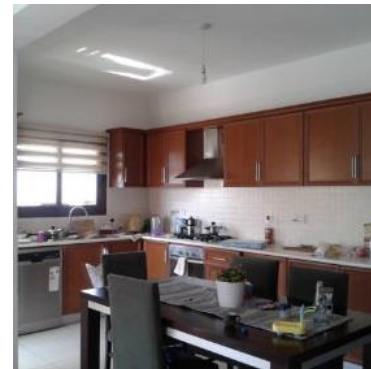
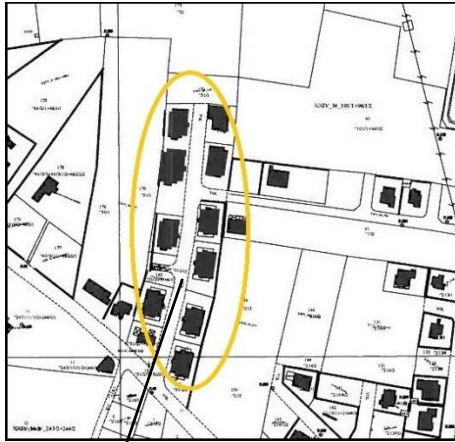
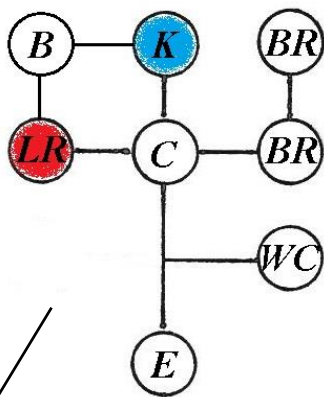


Table 4.12: Spatial Organization and Architectural Elements of Living room and Kitchen Spaces, Inventory No: 3.2

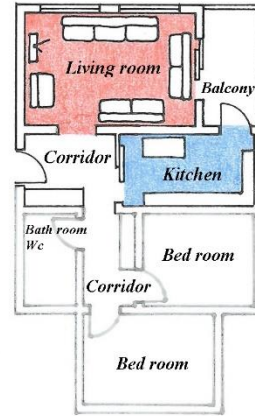


Town: **FAMAGUSTA**
 District: **YENİBOĞAZIÇI**
 Street: Çiftçioglu Sokak
 Date of Construction: Around 2010
 Number of Floors: 6

Space Organization:
S: Street
CO: Courtyard
B: Balcony
E: Entrance Hall
LR: Living Room
BR: Bed Room
C: Corridor
K: Kitchen
WC: WC & Bath Room



Living room is located near a corridor that has straight relation with entrance. Kitchen put back of the living room.



Pass the street, stairs and then received to entrance that connected straight with corridor. That has relation with living room and kitchen. Living room has straight relation to kitchen.

One living room's wall designed by window. That open to street views'. From one side, living room has straight relation with corridor. And actually has relation with balcony. Kitchen has view point to back of the apartment and open to balcony.



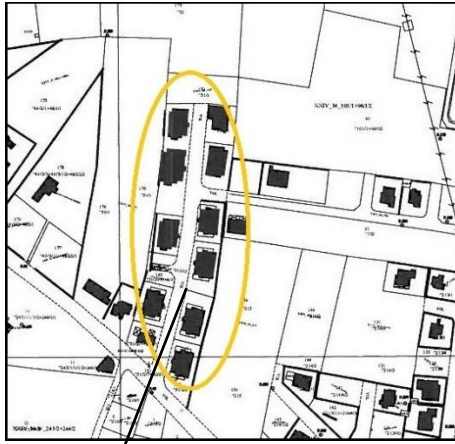
Use from window for day lighting and simple lamps' ceiling.

Use movable furniture in living room. That located round the TV. Use a little of fixtures on the walls and cupboards.

Use dining table and cupboards in kitchen.

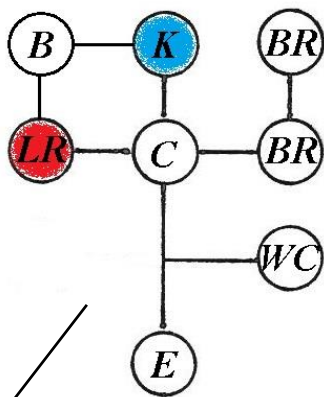


Table 4.13: Spatial Organization and Architectural Elements of Living room and Kitchen Spaces, Inventory No: 3.3

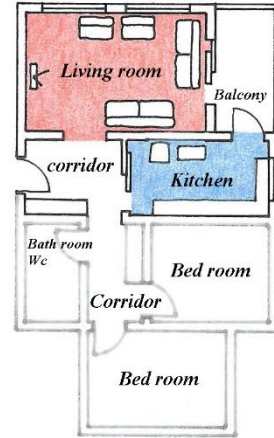


Town: **FAMAGUSTA**
 District: **YENİBOĞAZIÇI**
 Street: Çiftçioglu Sokak
 Date of Construction: Around 2010
 Number of Floors: 6

Space Organization:
S: Street
CO: Courtyard
B: Balcony
E: Entrance Hall
LR: Living Room
BR: Bed Room
C: Corridor
K: Kitchen
WC: WC & Bath Room



Living room is located near a corridor that has straight relation with entrance. Kitchen put back of the living room.



Pass the street, stairs and then received to entrance that connected straight with corridor. That has relation with living room and kitchen. Living room has straight relation to kitchen.

One living room's wall designed by window. That open to street views'. From one side, living room has straight relation with corridor. And actually has relation with balcony. Kitchen has view point to back of the apartment and open to balcony.



Use from window for day lighting and simple lamps' ceiling.

Use movable furniture in living room. That located round the TV. Use a little of fixtures on the walls and cupboards.

Use dining table and cupboards in kitchen.

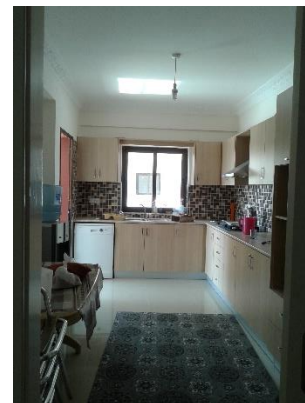
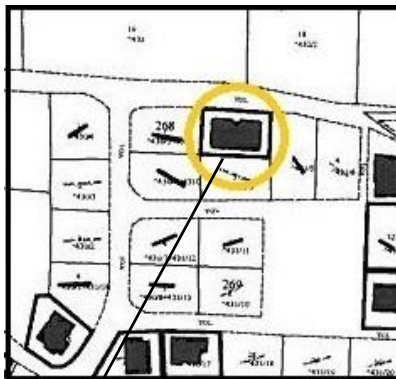
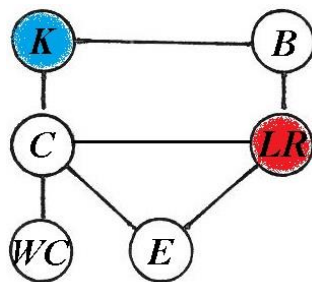


Table 4.14: Spatial Organization and Architectural Elements of Living room and Kitchen Spaces, Inventory No: 3.4

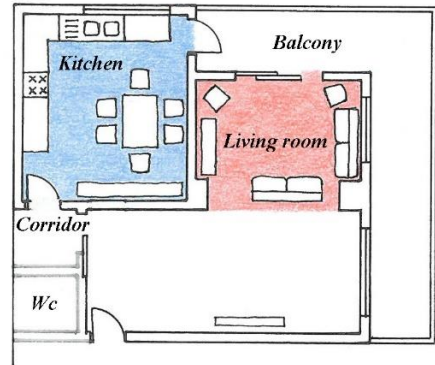


Town: **FAMAGUSTA**
 District: **YENİBOĞAZIÇI**
 Street: _
 Date of Construction: Around 2000
 Number of Floors: 2

Space Organization:
S: Street
CO: Courtyard
B: Balcony
E: Entrance Hall
LR: Living Room
BR: Bed Room
C: Corridor
K: Kitchen
WC: WC & Bath Room



Living room is located near an entry hall that has straight relation with entrance. Kitchen put back of the living room.



Pass the street, stairs and then received to entrance that connected straight with living room and from other hand with a corridor. The kitchen has relation with corridor and then with entry hall.

Two living room's walls designed by window. That open to street views' and balcony. From one side, living room has straight relation with entry hall. And actually has relation with balcony. The relation between kitchen and living room is corridor. Kitchen has view point to front of the apartment and open to balcony.



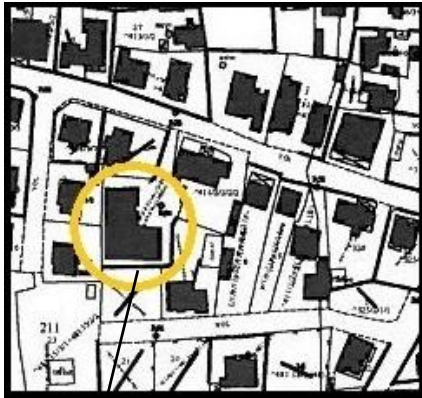
Use from window for day lighting and simple lamps' ceiling.

Use movable furniture in living room. That located round the TV. Use a little of fixtures on the walls and cupboards.

Use dining table and cupboards in kitchen.

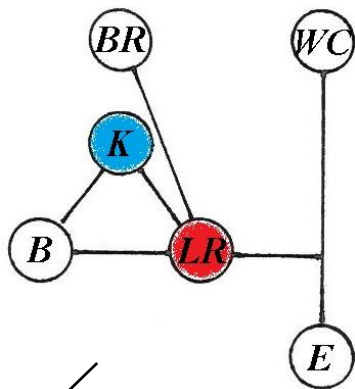


Table 4.15: Spatial Organization and Architectural Elements of Living room and Kitchen Spaces, Inventory No: 3.5

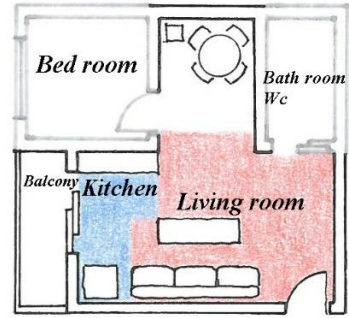


Town: **FAMAGUSTA**
 District: **YENİBOĞAZIÇI**
 Street: Shehit Bekir Etem Sokagi
 Date of Construction: Around 2005
 Number of Floors: 6

Space Organization:
S: Street
CO: Courtyard
B: Balcony
E: Entrance Hall
LR: Living Room
BR: Bed Room
C: Corridor
K: Kitchen
WC: WC & Bath Room

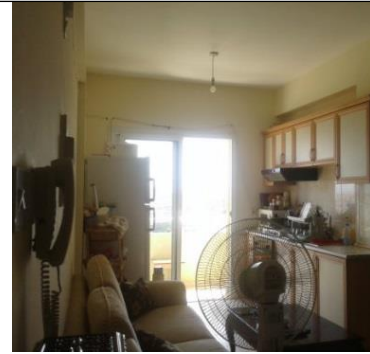


Living room is located near an entry hall that has straight relation with entrance. Kitchen located exactly near the living room.



Pass the street, stairs and then received to entrance that connected straight with living room. The kitchen has relation with living room.

One living room's walls designed by window. That open to street views' and balcony. There is no separation between living room and kitchen. Kitchen has view point to front of the apartment and open to balcony as same as living room.



Use from window for day lighting and simple lamps' ceiling.

Use movable furniture in living room. That located round the TV. There is no fixtures on the walls.

Use dining table between living room and kitchen. And use cupboards in kitchen.

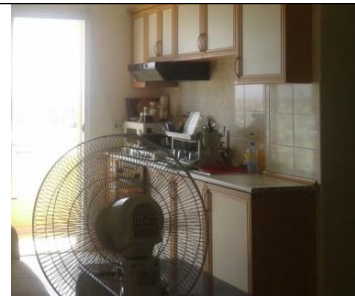


Table 4.16: Summary of Spatial Organization and Architectural Elements of Living room and Kitchen Spaces in Yeniboğaziçi Village Houses

Architectural Elements	Space Organization	Living room	Kitchen	Walls		Openings (Doors & Windows)		Lighting & Color	Furniture & Fixtures	
				Living room	Kitchen	Living room	Kitchen		Living room	Kitchen
				Inventories						
Contemporary Houses										
Inventory No: 1.1 				One wall without opening. Three walls with two doors & three windows.	One wall without opening. Three walls with two doors & two windows.	Two doors, open to entry hall & corridor. Three windows to street & back courtyard.	Two doors, open to corridor & back courtyard. Two windows to back courtyard.	Use window for day lighting. Simple lamp's ceiling. Use light color.	Movable furniture around TV. Dining table. Use traditional cover on furniture. Use carpet on the floor. Frames on walls & decorations.	Dining table. Cupboards on walls.
Inventory No: 1.2 				Two walls without opening. Two walls with one door & two windows.	One wall without opening. Three walls with two doors & two windows.	One door, open to entry hall. Two windows to street.	Two doors, open to corridor & back courtyard. Two windows to back courtyard.	Use window for day lighting. Simple luster's ceiling. Use light color.	Movable furniture. Use traditional cover on furniture. Use carpet on the floor. Frame on walls & decorations.	Movable Furniture. Dining table. Cupboards on walls. Frame on cupboards.
Inventory No: 1.3 				One wall without opening. Three walls with two doors & three windows.	One wall without opening. Three walls with two doors & a window.	Two doors, open to entry hall & corridor. Three window to street & back courtyard.	Two doors, open to corridor & back courtyard. One window to back courtyard.	Use window for day lighting. Simple lamp's ceiling. Use light color.	Movable Furniture around TV. Use traditional cover on furniture. Frame on walls & decorations.	Movable Furniture. Dining table. Cupboards on walls.
Inventory No: 1.4 				One wall without opening. Three walls with two doors & two windows.	Two walls without opening. Two walls with two doors & a window.	Two doors, open to entry hall & kitchen. Two windows to street & back courtyard.	Two doors, open to living room & back courtyard. A window to back courtyard.	Use window for day lighting. Simple lamp's ceiling. Use light color.	Movable Furniture around TV. Dining table.	Cupboards on walls.
Inventory No: 1.5 				Two walls without opening. Two walls with a door & a window.	One wall without opening. Three walls with two doors & two windows.	A door, open to entry hall. A window to back courtyard.	Two doors, open to corridor & back courtyard. Two windows to back courtyard.	Use window for day lighting. Luster's ceiling. Use light color.	Movable Furniture around TV. Use carpet on the floor. Frame on walls & decorations.	Dining table. Cupboards on walls. Frame on cupboards.

Single New Houses											
Inventory No: 2.1					First living room: Two walls without opening. Two walls with two doors. Other living room: One wall without opening. Three walls with a door & two windows.	One wall without opening. Three walls with two doors & two windows.	First living room: Two doors, open to corridor & balcony. Other living room: A door, open to kitchen. Two windows to courtyard.	Two doors, open to corridor & balcony. Two windows to back courtyard.	Use window for day lighting. Luster's ceiling. Use light color.	Movable Furniture around TV.	Dining table. Cupboards on walls.
Inventory No: 2.2					First living room: One wall without opening. Three walls with a door & two windows. Other living room: One wall without opening. Three walls with a door & four windows.	Four walls with two doors & two windows.	First living room: A door, open to entry hall. Two windows to street & back courtyard. Other living room: A door, open to entry hall. Four windows to street & back courtyard.	Two doors, open to corridor & balcony. Two windows to back courtyard.	Use window for day lighting. Luster's ceiling. Use light color.	First living room: Movable Furniture around TV. Other living room: Movable furniture. Dining table. Frame on walls & decorations.	Dining table. Cupboards on walls.
Inventory No: 2.3					One wall without opening. Three walls with two doors & two windows.	One wall without opening. Three walls with two doors & two windows.	Two doors, open to entrance & corridor. Two windows to street & back courtyard.	Two doors, open to corridor & back courtyard. Two windows to back courtyard.	Use window for day lighting. Luster's ceiling. Use light color.	Movable Furniture around TV. Use traditional cover on furniture. Frame on walls & a few decoration.	Dining table. Cupboards on walls.
Inventory No: 2.4					One wall without opening. One wall with a window.	One wall without opening. Two walls with a door & a window & an opening.	A window to back courtyard.	A door, open to back courtyard. An opening, open to dining room. A window to back courtyard.	Use window for day lighting. Luster's ceiling. Use other colors besides of light color.	Movable furniture. Frame on walls & a few decoration. Use carpet on the floor.	Dining table. Cupboards on walls.
Inventory No: 2.5					One wall without opening. Three walls with two opening & a window.	Two walls without opening. One wall with two windows.	Two openings, open to corridor & kitchen. A window to back courtyard.	Two windows to back courtyard.	Use window for day lighting. Luster's ceiling. Use light color.	Movable furniture around TV. Use carpet on the floor.	Dining table. Cupboards on walls.

Apartments											
Inventory No: 3.1					One wall without opening. Three walls with a door, two openings & two windows.	One wall without opening. Three walls with two doors, an opening & a window.	Two openings, open to corridor & kitchen. One door open to balcony. Two windows to street.	Two doors open to corridor & balcony. One opening open to living room. One window to street.	Use window for day lighting. Luster's ceiling. Use other colors besides of light color & wall papers.	Movable furniture around TV. A few decoration.	Dining table. Cupboards on walls.
Inventory No: 3.2					One wall without opening. Three walls with a door, an opening & two windows.	One wall without opening. Three walls with two doors & a window.	One opening open to corridor. One door open to balcony. Two windows to street.	Two doors open to corridor & balcony. One window to street.	Use window for day lighting. Luster's ceiling. Use light color.	Movable furniture around TV. Use carpet on the floor.	Dining table. Cupboards on walls.
Inventory No: 3.3					One wall without opening. Three walls with a door, an opening & two windows.	One wall without opening. Three walls with two doors & a window.	One opening open to corridor. One door open to balcony. Two windows to street.	Two doors open to corridor & balcony. One window to street.	Use window for day lighting. Luster's ceiling. Use light color.	Movable furniture around TV. Use carpet on the floor.	Dining table. Cupboards on walls.
Inventory No: 3.4					One wall without opening. Two walls with a door, an opening & a window.	Two walls without opening. Two walls with two doors & a window.	One opening open to entry hall. One door open to balcony. One window to street.	Two doors open to corridor & balcony. One window to street.	Use window for day lighting. Luster's ceiling. Use light color.	Movable furniture around TV.	Dining table. Cupboards on walls.
Inventory No: 3.5					One wall without opening. Three walls with two doors.	One wall without opening. One wall with one door.	Two doors open to entrance & balcony.	One door open to balcony.	Use window for day lighting. Luster's ceiling. Use light color.	Movable furniture around TV.	Dining table. Cupboards on walls.

Chapter 5

CONCLUSION

By the continuously changes in the world, it can be see that effects on various factors. Architecture and actually domestic architecture and interior design are also one of these aspects which are changing continuously. Developed the new materials, other than, new technologies have an effect on the form of the buildings, especially houses and their organizations, the elements and decorations. Additional to traditional house building processes, nowadays we are able to see many attempts to create and also construct houses in certain sizes in a variety of techniques and forms without having real user requirements.

As it was mentioned before and according to points that said above, house has started to change in order to fulfil the revised needs of the users in continues manner. The living space has always been the most important functional space of our houses because it has the largest area and opens directly to the entrance hall or directly to the exterior area. It has the most elegant furnishing compared to the other spaces since it is designed for visitors rather than family members. The usage of these areas is influenced by the needs, economic status, and the level of the culture in the family. The living ideas that was evaluated in this thesis have evolved through centuries in several civilizations. This thesis investigated values related to “living spaces” in history of Northern Cyprus and searched their validity in contemporary life.

Consequently, as it was mentioned Behsh points out and according to evaluation of case studies in this thesis, the new sort of homes persons cannot follow their own traditional habits and also their particular cultures' of lifestyle.

- In the course of certain cycle, Cyprus has been under the control of numerous civilizations and societies and also it was affected greatly through the cultural structure of the civilizations.
- The relation between individuals in Cyprus is so powerful because it is a small Island.
- In the past few years, parallel to the improvement of production techniques, material and technology, variations happened in the elements of spaces.
- As mentioned earlier, father was the main character in the Traditional Turkish family structure but today women also started to work and has achieved economic and social independence in the society. Therefore, no hierarchical order can be detected in Turkish families with women being mostly equal with the other family members. So, father is not at the focal point any more.
- The location of living room in houses was in front of the house that has connection with outside with an entry hall. And also they have view to street and court yard with windows on walls. Kitchen located at last part of the house (back of the living room) that has connection to back courtyard of house. Corridors are the connection between living rooms and kitchens. So living rooms and kitchen spaces do not have straight connection with together.
- Windows once made very small, have become wider to allow the opportunity to create wide views.

- Through this modern era, some fixtures, such as wardrobes can be observed that are to some extent similar to the ones once used at the Traditional Turkish house.
- Smaller families became widespread and this has subsequently resulted in flexible life styles, and suitable furniture harmonious with activities.
- Influenced by the Western World Today, the movable furniture is the most widely used built-in furniture in Traditional Turkish House. This provides flexibility in arrangements so that objects like television can be placed at their best positions.
- For lighting during the day use from windows and electric bulbs. That use from which type of electric bulbs (simple lamps or lusters) has depends to tendencies of people. The application of Ampoules (electric bulbs) as well as artificial lighting have turned into common fixtures mostly for aesthetical usage. Use light color that the most reason for using light color is climate of the Island.

The findings indicate that by the continuously changing in architecture, villages were flooded with houses that looked different from vernacular dwellings. However, the lifestyles in the rural were still conventional. The contemporary rural houses was a hybrid between modern and fashionable and the comfortable of an Eastern Mediterranean lifestyle.

REFERENCES

Albrecht, P. J. (1994). *North Cyprus a Travel Book*. London, Havellia Publishing

Altman, I. (1980). *Culture and Environment*. Cambridge University Press, Cambridge

Arab, K. (2012). *Vernacular Architecture of the 21st Century*. Vol 2. April. Eastern Mediterranean University

Ardrey, R. (1966). *The Territorial Imperative*. New York: Atheneum

Arseven, N. (2006). *Ornamentation of Traditional Domestic Doors in North Cyprus*. Eastern Mediterranean University

Behsh, M. B. (1993). *Towards Housing in Harmony with Place*. Sweden: Lund Institute of Technology, Lund University

Boğaç, C. (2005). *Architecture for Meaning- Expression of Social Values through Urban Housing in Gazimağusa, North Cyprus*: Lambert Academic Publishing

Brown, A. (2001). *Architecture as System, the Modern Movement in Design*. [Online], Available at: <http://www.geocities.com/designmode/modern-movement.htm>

Buttimer, A. (1980). *Home, reach and the sense of Place*. New York: St. Martin's Press

- Çakın, Ş. (1988). *Mimari Tasarım, Toplum ve Çerve*. Özal Matbaası, İstanbul
- Ching, F. (1979). *Architecture: Form-Space and Order*. Van Nostrand Reinhold, New York
- Ching, F. (2005). *Interior Design Illustrated*. Canada: John Wiley and Sons, Inc
- Ching, F. (2007). *Architecture-Form, Space and Order*: John Wiley and Sons, Inc
- Correa, C. (1985). *The New Landscape, Bombay, The book Society of India*. Sage
- Crisp, B. (1998). *Human Spaces-Life Enhancing Designs for Healing, Working and Living*. United States of America: Rockport Publishers, Inc
- Davarpanah, S. (2013). *Analyzing the Characteristics of British Period Residential Building Façade in the Walled City of Nicosia*. Eastern Mediterranean University
- Denel, B. (1979). *A Method for basic Design*. Ankara, Middle East Technical University
- Doratlı, N. & Paşaoğulları, N. (2004). *Measuring Accessibility and Utilization of Public Spaces in Famagusta*. Eastern Mediterranean University
- Doratlı, N. (2000). *A Model for Conservation and Revitalization of Historic Urban Quarters in Northern Cyprus, Famagusta*. Eastern Mediterranean University

- Ergüden, T. (2012). *The Important of Soft Furnishing in Interior Spaces. Pilot study-Living Spaces*. Eastern Mediterranean University
- Fasli, M. (1997). *The Use of Residential Exterior Space in Northern Cyprus*. Eastern Mediterranean University
- Faulkner, S. (1979). *Planning a Home*. Holt, Rinehart and Winston, New York
- Grabar, O. (1992). *The Mediation of Ornament*. New Jersey, Princeton University Press
- Güvenç, B. (1985). *Kültür Konusu ve Sorunlarımız*. Remzi Kitabevi, Istanbul
- Habraken, N. J. (1998). *The Structure of the Ordinary Form and Control in the Built Environment*
- Hafizoğlu, Ş. (2000). *Stone use in British Domestic architecture in North Cyprus*. Eastern Mediterranean University
- Ilkin, F. (2000). *Cultural Influences on Architecture Features: An Investigation of Different Ethnic Groups in Northern Cyprus*. Eastern Mediterranean University
- Katz, S. Gavena, S. Weiss, B. Hall, D. Ardley, S. & Grey, J. (1998). *The Complete Home Design book*. Great Britain: Dorling Kindersley Limited
- Kapasuz, A. G. (2001). *The use of Window in Northern Cyprus architecture*. Eastern Mediterranean University

Kaynama, S. (2014). *Investigation of Formal Aesthetic Elements in Living Spaces*.
Eastern Mediterranean University

Kent, S. (1990). *A Cross-cultural study of Segmentation, Architecture, and the Use of Space*

Kiessel, M. Besim Y. D. Tozan, A. (2011). *The New Architectural Classicism in Northern Cyprus*. METU Journal of the Faculty of Architecture, Vol. 28-No.2,
Ankara

Klassen, F. (2001). *Transformable Personal Space within a Communal Setting-Housing for the Homeless*. Ryerson University, Faculty of Communication and design, school of Interior Design

Kuban, D. (1986). *Turkish Culture and Arts*. BBA. Istanbul

Küçükerman, Ö. (1991). *Turkish House-In search of Spatial Identity*. Temal Printing,
Istanbul

Lancaster, M. (1994). *The New European Landscape*. Butterworth-Heineman Ltd,
Oxford

Madanipour, A. (1998). *Tehran: The Making of a Metropolis*. New York: John Wiley
& Sons

- Madanipour, A. (2003). *Public and Private Spaces of the City*. London and New York: Routledge
- Mansouri Tehrani, M. (2012). *The Role of Technology in Providing the Efficiency of Kitchen Design*. Eastern Mediterranean University
- Marcus, C. C & Francis, C. (1990). *People Place, Design Guidelines for Urban Open Spaces*. Van Nostrand Reinhold, New York
- Marcus, C. C. (1995). *House as a mirror of self*. Berkeley, CA: Conari Press Gosling
- Meiss, V. P. (1990). *Elements of Architecture*. Van Nostrand Reinhold, London
- Mirmoghtadaei, M. (2009). *Process of Housing Transformation in Iran*
- Mitton, M. & Nystuen, C. (2011). *Residential Interior Design: A Guide to Planning Spaces*, New York: Wiley
- Nielson, K. J. & Taylor, D. A. (1994). *Interiors an Introduction*. Boston Massachusetts
- Nielson, K. J. (2007). *Interior Textiles- Fabrics, Applications and Historic style*
- Noel, E. E. (2011). *Domestic Architecture in Benin City: A Study of Continuity and Change*. Covenant University, Department of Architecture
- Oktay, D. (1994). *Essay on Urban Design (1)*. Eastern Mediterranean University Press, Gazimagusa

- Okday, D. (1994). *Essay on Urban Design (2)*. Eastern Mediterranean University Press, Gazimagusa
- Okday, D. (1996). *Notes on Urban Design*. Eastern Mediterranean University, Gazimagusa
- Okday, D. (2001). *Design with the climate in housing environments:an analysis in Northern Cyprus*. Eastern Mediterranean University, Gazimagusa
- Okday, D. (2002). *The quest for urban identity in the changing context of the city*. Eastern Mediterranean University, Gazimagusa
- Önal, Ş. Ulaş Dağlı, U. (1996). *Revitalization of Yeniboğaziçi (Ayios Seryios) Village in Northern Cyprus*
- Öngül, Z. (1998). *Ornamentation in Interior Spaces (Case Study: Old Houses in Nicosia)*. Eastern Mediterranean University
- Ozay, N. (1998). *Influences of Stylistic Tendencies on the Interior Design in Cypriot Architecture*. Eastern Mediterranean University
- Özlem, D. (1986). *Kültür Bilimleri ve Kültür Felsefesi, Remzi Kitabevi*. Istanbul
- Pile, J. (1995). *Interior Design second edition*. New York: Hary N. Abrams, Inc
- Pile, J. (2009). *A History of Interior Design third edition*. London: Laurence King Publishing Ltd

- Pheasant, S. (2005). *Ergonomics in the Home*, In S. Pheasant, *Bodyspace: Anthropometry, Ergonomics and the Design of Work*. London: CRC Press
- Poyatos, F. (1972). *The Communication System of the Speaker Actor and His Culture: a Preliminary Investigation*. Linguistics
- Preston, C. (2000). *Social Continuity and Change and Social Theory: Society and Culture in Service*, an Unpublished Lecture Delivered In Nagle College
- Pullhan, H. (2004). *Influence of the Cultural Factors on Spatial Organization of the Traditional Turkish House of Lefkoşa*. Eastern Mediterranean University
- Rapoport, A. (1977). *Human Aspects of Urban Form*. Wheaton and Co Ltd, Exeter
- Rapoport, A. (1982). *The Meaning of the Built Environment*. Sage, Beverly Hills
- Rutman, D. L. & Freedman, J. L. (1988). *Anticipating Relocation: Coping Strategies and the meaning of home for older people*. Canadian Journal on aging
- Rubinstein, R. L. (1989). *The home environment of older people: A description of the psychological processes linking person to place*. Journal of Gerontology: Social Sciences
- S. D. Ko. S. J. Mannarelli, T. & Morris, M. E. (2002). *A Room with a cue: Personality judgments based on offices and bedrooms*. Journal of Personality and Social Psychology

Sorrell, K. (2000). *Modern Comfort, Great Britain*: Conran Octopus Limited

Sudjic, D. (1984). *The House Style book*

Taylor, L. & Blake, J. (1998). *Design and Decorate Living Rooms*. London: New York
Holland Publishers

Tozan, A. Akın, G. (2009). *İngiliz Sömürge Dönemi ve Sömürge Sonrası Kuzey
Kıbrıs'ta Kent ve Mimarlık (1878-1960)*. İTÜ Dergisi/a Mimarlık, Vol. 8, No: 2,
September, İstanbul

Tozan, A. (2008). *Bir Sömürge Modernleşme Örneği Olarak Kıbrıs'ta Kent ve
Mimarlık (1878-1960)*. İstanbul, Istanbul Technical University

Wekerle, R. G. (1991). *Gender and Housing in Toronto*. A Paper / Prepared for the
city of Toronto's Institute on Women and Work, City of Toronto

Wahl, H. W. Scheidt, R. J. & Windley, P. G. (2004). *Annual Review of Gerontology
and Geriatrics*. Volume 23, United States: Springer Publishing Company, Inc

Wissinger, J. (1995). *The Interior Design Handbook*. New York: Roundtable Press,
Inc

Yıldız, N. (1997). *History of Cypriot Civilization*. Lecture Notes, Eastern
Mediterranean University Press

URL1: <http://www.teonline.com/knowledge-center/home-furnishing.html>






URL 2: <http://www.cittaslow.org/network/location/414>

APPENDIX

Appendix 1: Additional Visual Data of No: 1.1

Interior	Living Room		
	Kitchen		
	Other Spaces		
Exterior			

Appendix 2: Additional Visual Data of No: 1.2

Interior	Living Room		
	Kitchen		
	Other Spaces		
Exterior			



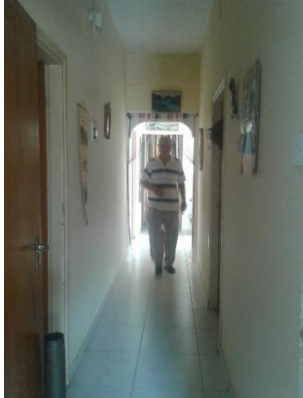

Appendix 3: Additional Visual Data of No: 1.3

<p>Interior</p>	<p>Living Room</p>		
	<p>Kitchen</p>		
	<p>Other Spaces</p>		
<p>Exterior</p>			




Appendix 4: Additional Visual Data of No: 1.4

Interior	Living Room		
	Kitchen		
	Other Spaces		
Exterior			





Appendix 5: Additional Visual Data of No: 1.5

Interior	Living Room	 A photograph of a living room with a grey sofa, a coffee table, and a television set. The room is decorated with various items on the walls and shelves.	 A photograph of a living room with a beige sofa, a coffee table, and a television set. The room is decorated with various items on the walls and shelves.
	Kitchen	 A photograph of a kitchen with white cabinets, a dining table, and a window. A person is visible in the background.	 A photograph of a kitchen with white cabinets, a dining table, and a window. A person is visible in the background.
	Other Spaces	 A photograph of a hallway with a person walking away from the camera. The hallway has a light-colored floor and walls.	
Exterior	 A photograph of the exterior of a house. The entrance is covered by a porch with a stone wall and a door. There are plants and a bicycle in the foreground.		





Appendix 6: Additional Visual Data of No: 2.1

Interior	Living Room		
	Kitchen		
	Other Spaces		
Exterior			

Appendix 7: Additional Visual Data of No: 2.2

Interior	Living Room	 A wide-angle photograph of a living room. It features a white sectional sofa, a dark coffee table, and a dining table with chairs in the background. There are windows with curtains and a framed picture on the wall.	 A photograph of a living room focusing on a television set placed on a dark wooden console. A framed picture hangs on the wall above the TV. A small table is visible to the left.
	Kitchen	 A photograph of a kitchen with wooden cabinetry and a dining table with chairs. A window is visible in the background.	 A photograph of a dining area showing a table with chairs and a doorway leading to another room.
	Other Spaces	 A photograph showing a view through a glass door into another room, possibly a bedroom or living area. A potted plant is visible in the foreground.	
Exterior	 A photograph of the exterior of a two-story house with a light-colored facade. Several tall palm trees are in the foreground, and a paved road is visible.		


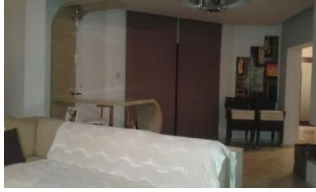


Appendix 8: Additional Visual Data of No: 2.3

Interior	Living Room		
	Kitchen		
	Other Spaces		
Exterior			

Appendix 9: Additional Visual Data of No: 2.4

Interior	Living Room		
	Kitchen		
	Other Spaces		
Exterior			

Appendix 10: Additional Visual Data of No: 2.5

Interior	Living Room		
	Kitchen		
	Other Spaces		
Exterior			

Appendix 11: Additional Visual Data of No: 3.1

Interior	Living Room		
	Kitchen		
	Other Spaces		
Exterior			

Appendix 12: Additional Visual Data of No: 3.2

Interior	Living Room		
	Kitchen		
	Other Spaces		
Exterior			

Appendix 13: Additional Visual Data of No: 3.3

Interior	Living Room	 A photograph of a living room featuring a patterned sofa, a coffee table, and a large window with curtains.	 A photograph of a living room showing a television on a stand, a potted plant, and a window.
	Kitchen	 A photograph of a kitchen with light-colored cabinetry, a countertop, and a window.	
	Other Spaces	 A photograph of a hallway with white walls and a doorway leading to another room.	
Exterior	 A photograph of a multi-story apartment building with white and red accents, a black car parked in front, and a clear blue sky.		

Appendix 14: Additional Visual Data of No: 3.4

Interior	Living Room		
	Kitchen		
	Other Spaces		
Exterior			

Appendix 15: Additional Visual Data of No: 3.5

Interior	Living Room		
	Kitchen		
	Other Spaces		
Exterior			