

Interpreting the Spatial Organization of Adaptive-Reuse Museums Considering Crowds Issue in Circulation Routes

Ola Haj Saleh

Submitted to the
Institute of Graduate Studies and Research
in partial fulfillment of the requirements for the degree of

Master of Science
in
Interior Architecture

Eastern Mediterranean University
September 2020
Gazimağusa, North Cyprus

Approval of the Institute of Graduate Studies and Research

Prof. Dr. Ali Hakan Ulusoy
Director

I certify that this thesis satisfies all the requirements as a thesis for the degree of Master of Science in Interior Architecture.

Assoc. Prof. Dr. Zehra Öngül
Chair, Department of Interior
Architecture

We certify that we have read this thesis and that in our opinion it is fully adequate in scope and quality as a thesis for the degree of Master of Science in Interior Architecture.

Assoc. Prof. Dr. Afet Coşkun
Supervisor

Examining Committee

1. Prof. Dr. Sevinç Kurt

2. Assoc. Prof. Dr. Hacer Başarır

3. Assoc. Prof. Dr. Afet Coşkun

ABSTRACT

The integrated journey inside the exhibition halls in museums can be achieved if the visitor realizes the full message of the exhibits. This is happening not only by impacting what the visitor perceives visually but also by focusing on the spatial organization of the building. The problem that designers incur is finding solutions for the crowd and gathering issues on circulation routes. The spatial organization for museum has direct effects on the observation process of the visitor inside or between the exhibition halls. It offers the museum its circulation routes, thus the difficulty to reach and identify displayed items and the waiting time which are happened due to the problem considered as the negative impacts on the visitors' journey. This research is aiming to figure out a spatial organization that discount the crowd's problem, finds out how the circulation route between and inside the halls deal with the gathering issues. This study is trying to answer how people may orient themselves successfully and get all the information in the halls of the exhibition by studying the circulation routes in relation to the general layout plan of the museums. Focusing on how the design can save the waiting time of the visitors during the experience inside the Museums. Thesis questions are: How the spatial organization of the museums affects the circulation routes? What sort of layout can avoid the crowd issues on the circulation routes? The limitation of this study is on the museums in European cities that formed by the adaptive reuse way of the historical buildings. This study focuses on the most top-ranked visited museums in the world of the year 2018 sorted by the theme index museum AECOM and TEA. The methodology is both quantitative and qualitative method & data analysis based on the literature review by analyzing six case studies, on the focus of the relation between the general layout type and the circulation routes.

The findings in this research aimed to understand how international museums utilize space to be a unique experience for its visitors. At the conclusion, some rules to be used while designing museums and others to be avoided.

Keywords: Spatial Organization, Circulation Routes, Crowds, Museum

ÖZ

Müzelerin sergi salonlarının içindeki entegre yolculuğu , ziyaretçinin sergiyi fark ettiği zaman elde edilebilir. Bu sadece ziyaretçinin görsel olarak algıladıklarını etkilemekle değil, aynı zamanda binanın mekansal organizasyonuna odaklanarak da oluyor. Tasarımcıların karşılaştığı sorun, kalabalık için çözümler bulmak ve dolaşım yolları ile ilgili konuları toplamaktır . Müzenin mekansal organizasyonu, ziyaretçinin sergi salonlarının içinde veya salonların aralarında, gözlem sürecini doğrudan etkiler. Bu konu müzeye dolaşım rotalarını, dolayısıyla sergilenen eşyalara ulaşma ve tespit etme zorluğu ve ziyaretçinin yolculuğuna olumsuz etki olarak değerlendirilen sorun nedeniyle yaşanan bekleme sürelerini sunar. Bu araştırma, kalabalığın problemini azaltan mekansal bir organizasyon bulmayı amaçlamaktadır, salonlar arasındaki ve içindeki dolaşım yolunun toplanma sorunlarıyla nasıl başa çıktığını öğrenir. Bu çalışma, müzelerin genel yerleşim planına göre dolaşım yollarını inceleyerek, insanların kendilerini nasıl başarılı bir şekilde yönlendirebileceklerini ve sergi salonlarındaki tüm bilgileri nasıl elde edebileceklerini cevaplamaya çalışıyor. Müze içi deneyim sırasında tasarımın ziyaretçilerin bekleme süresinden nasıl tasarruf edebileceğine odaklanmaktadır. Tez soruları: Müzelerin mekansal organizasyonu dolaşım yollarını nasıl etkiliyor? Dolaşım yollarındaki kalabalık sorunlarından ne tür bir düzen önerilmektedir? Bu çalışmanın sınırları, tarihi binaların uyarlanabilir yeniden kullanım biçimiyle oluşan Avrupa şehirlerindeki müzeler üzerinedir. Bu çalışma, tema indeksi müzesi AECOM ve TEA'ya göre sıralanan 2018 yılının en çok ziyaret edilen müzelerine odaklanmaktadır. Metodoloji, genel yerleşim tipi ve dolaşım yolları arasındaki ilişkinin odağına dayalı altı vaka çalışmasını analiz ederek literatür taramasına dayanan hem nicel hem de nitel yöntem ve veri analizidir. Bu araştırmadaki

bulgular, uluslararası müzelerin mekanı ziyaretçileri için benzersiz bir deneyim olarak nasıl kullandığını anlamayı amaçladı. Sonuç olarak, müze tasarlarken bazı kurallar kullanılırken, diğerlerinden de kaçınılması gerekir.

Anahtar Kelimeler: Mekansal Organizasyon, Dolaşım Yolları, Kalabalıklar, Müze

My thesis dedicated to whom gave
me unending affection, motivation, and assistance “My Family”

ACKNOWLEDGMENT

Showing my appreciation to the Incentive, advice, & guidance from very early stages of this study which I received from my supervisor Assoc.Prof.Dr. Afet Celiker Coşkun. She has provided me with endless motivation and guidance in numerous ways, above all and most important. Her ideas, interactions, and interests have really inspired and enriched my development.

My gratitude to my friends who helped and inspired me across my studies such as Ersun Eruz , Mariam Isied ,Raji Abdulrazak and Eman Is and all the worker in our Department.

To my Father who supported me with his endless love and Mother with her experience as a holder for Master Degree. I feel more grateful than you imagine.

TABLE OF CONTENTS

ABSTRACT.....	iii
ÖZ.....	v
DEDICATION	vii
ACKNOWLEDGMENT.....	viii
LIST OF TABLES	xi
LIST OF FIGURES	xii
1 INTRODUCTION	1
1.1 Problem Statement	3
1.2 Aims & Objectives	3
1.3 Methodology	4
1.4 Limitations and Delimitations	5
1.5 Scope of the Thesis	6
2 MUSEUMS AS ADAPTIVE REUSE HISTORICAL BUILDINGS	7
2.1 Historic Building.....	7
2.1.1 A Notion about Adaptive Reuse Historical Buildings	8
2.1.2 Historical Buildings as Museums.....	9
2.2 Museums	12
2.2.1 Origin of Museum	13
2.2.2 History of Museum.....	14
2.2.3 Types of Museum	17
3 SPATIAL ORGANIZATION.....	19
3.1 Spatial Organization.....	19
3.2 Spatial Circulation.....	23

3.3 Museums as a Space	23
3.3.1 Circulation of Museum Space.....	26
3.3.2 Circulation Routes (Pathway) and Layout Organization Relations.....	27
4 CASE STUDIES AND ANALYSIS.....	29
4.1 Overall Research Methodology.....	29
4.2 Data Collection and Data Analysis Methods.....	30
4.2.1 Inventory Table: Introduction to the Museum.....	30
4.2.2 Inventory Table: Layout Analysis.....	33
4.3 Case Studies.....	35
4.3.1 Louvre Museum, Paris, France.....	35
4.3.2 The Vatican Museum, Vatican City, Italy	49
4.3.3 British Museum, London, UK.....	59
4.3.4 National Gallery, London, UK.....	70
4.3.5 Natural History Museum, London, UK.....	81
4.3.6 Victoria & Albert Museum, London, UK.....	84
4.4 Finding.....	99
5 CONCLUSION	104
REFERENCES	107

LIST OF TABLES

Table 4.1: Inventory Table: Introduction to the Museum.....	32
Table 4.2: Inventory Table: Layout Analysis.....	34
Table 4.3: Inventory Table: Introduction to the Louvre Museum.....	37
Table 4.4: Layout Analysis of Louvre Museum Five Floors.....	48
Table 4.5: Inventory Table: Introduction to the Vatican Museum.....	51
Table 4.6: Layout Analysis of Vatican Museum Three Floors.....	58
Table 4.7: Inventory Table: Introduction to the British Museum.....	61
Table 4.8: Layout Analysis of British Museum Three Floors	69
Table 4.9: Inventory Table: Introduction to the National Gallery	73
Table 4.10: Layout Analysis of National Gallery three of the Floors.....	80
Table 4.11: Inventory Table: Introduction to the Vitoria & Albert.....	86
Table 4.12: Layout Analysis of V &A Museum Six Floors	98
Table 4.13: The Inventory Table for the Six Museums.....	103

LIST OF FIGURES

Figure 1.1: Limitation & Delimitation	5
Figure 1.2: Louvre Museums in Paris (URL 1)	10
Figure 1.3: Tate Modern Museum, UK (URL 2)	11
Figure 1.4: Interior view for Tate Modern Museum (URL 3)	11
Figure 1.5: Bibliotheca Alexandrina (Ancient World Wonder, 2003)	13
Figure 3.1: The Central Organizing Space (Ching, 2007)	20
Figure 3.2: Linear Organization (Ching, 2007)	20
Figure 3.3: Radial Organization (Ching, 2007)	21
Figure 3.4: Clustered Organization (Ching, 2007).....	22
Figure 3.5: Grid Organization (Ching, 2007).....	22
Figure 3.6: Loop	28
Figure 3.7: Linear Procession	28
Figure 3.8: Core.....	28
Figure 3.9: Labyrinth	28
Figure 3.10: Complex	28
Figure 4.1: Floor -2, Linear Type of Organization, Louvre Museum.....	38
Figure 4.2: Floor -1, Radial Type of Organization, Louvre Museum	39
Figure 4.3: Floor 0, Linear Type of Organization, Louvre Museum	39
Figure 4.4: Floor 1, Linear Type of Organization, Louvre Museum	40
Figure 4.5: Floor 2, Linear Type of Organization, Louvre Museum.....	40
Figure 4.6: Floor -2, Access points, Exhibitions area & Foyers, Louvre Museum	41
Figure 4.7: Floor -1, Access points, Exhibitions area & Foyers, Louvre Museum....	41
Figure 4.8: Floor 0, Access points, Exhibitions area & Foyers, Louvre Museum.....	42

Figure 4.9: Floor 1, Access points, Exhibitions area & Foyers, Louvre Museum.....	42
Figure 4.10: Floor 2, Access points, Exhibitions area & Foyers, Louvre Museum...	43
Figure 4.11: Floor -2, Linear Procession, Louvre Museum.....	44
Figure 4.12: Floor -1, Core, Louvre Museum	44
Figure 4.13: Floor 0, Linear procession, Louvre Museum	45
Figure 4.14: Floor 1, Linear procession, Louvre Museum	45
Figure 4.15: Floor 2, Linear procession, Louvre Museum.....	46
Figure 4.16: Vatican Museum (URL 5)	49
Figure 4.17: Lower Floor, Linear Organization, Vatican Museum.....	52
Figure 4.18: Upper Floor, Linear Organization, Vatican Museum.....	53
Figure 4.19: Basement Floor, Linear Organization, Vatican Museum.....	53
Figure 4.20: Lower Floor, Access points, Exhibitions area & Foyers, Vatican Museum.....	54
Figure 4.21: Upper Floor, Access points, Exhibitions area & Foyers, Vatican Museum.....	54
Figure 4.22: Basement Floor, Access points, Exhibitions area & Foyers, Vatican Museum.....	55
Figure 4.23: Lower Floor, Linear procession, Vatican Museum.....	55
Figure 4.24: Upper Floor, Linear procession, Vatican Museum	56
Figure 4.25: Basement Floor, linear procession, Vatican Museum	56
Figure 4.26: Montagu House (URL 6).....	59
Figure 4.27: Ground Floor, Radial Organization, British Museum.....	62
Figure 4.28: Upper Floor, Centralized Organization, British Museum	63
Figure 4.29: Lower Floor, Linear Organization, British Museum.....	63

Figure 4.30: Ground Floor, Access points, Exhibitions area & Foyers, British Museum	64
Figure 4.31: Upper Floor, Access points, Exhibitions area & Foyers, British Museum	65
Figure 4.32: Lower Floor, Access points, Exhibitions area & Foyers, British Museum	66
Figure 4.33: Ground Floor, Core, British Museum.....	66
Figure 4.34: Upper Floor, Loop, British Museum.....	67
Figure 4.35: Lower Floor, Linear procession, British Museum.....	67
Figure 4.36: Interior of Kings Mews (URL 7).....	71
Figure 4.37: The Frontage of Carlton House (URL 8).....	71
Figure 4.38: Floor -2, Linear Organization, National Gallery.....	74
Figure 4.39: Ground Floor (0), Radial Organization, National Gallery.....	70
Figure 4.40: Floor 2, Radial Organization, National Gallery.....	75
Figure 4.41: Floor-2, Access points, Exhibitions area & Foyers, National Gallery...	76
Figure 4.42: Ground Floor, Access points, Exhibitions area & Foyers, National Gallery.....	76
Figure 4.43: Floor 2, Access points, Exhibitions area & Lobbies, National Gallery.	77
Figure 4.44: Floor-2, Linear Procession, National Gallery	77
Figure 4.45: Ground Floor (0), Complex, National Gallery.....	78
Figure 4.46: Floor 2, Core, National Gallery.....	78
Figure 4.47: International Exhibition building of 1862, London (URL 10)	81
Figure 4.48: Architectural Drawing for Natural history museum, 1883 (URL 12)....	82
Figure 4.49: Map for Natural History Museum (URL 13)	83
Figure 4.50: Central Hall, Natural History Museum (URL 11)	83

Figure 4.51: Exterior view of Brompton Park House (URL 14)	84
Figure 4.52: Floor -1, Linear Organization, V & A Museum.....	87
Figure 4.53: Floor 0, Radial Organization, V & A Museum.....	88
Figure 4.54: Floor 1, Linear Organization, V & A Museum	88
Figure 4.55: Floor 2, Linear Organization, V & A Museum	89
Figure 4.56: Floor 3, Linear Organization, V & A Museum.....	89
Figure 4.57: Floor 4, Linear Organization, V & A Museum.....	90
Figure 4.58: Floor -1, Access points, Exhibitions area & Lobbies, V & A Museum..	90
Figure 4.59: Floor 0, Access points, Exhibitions area & Lobbies, V & A Museum...	91
Figure 4.60: Floor 1, Access points, Exhibitions area & Lobbies, V & A Museum...	92
Figure 4.61: Floor 2, Access points, Exhibitions area & Lobbies, V & A Museum...	92
Figure 4.62: Floor 3, Access points, Exhibitions area & Lobbies, V & A Museum...	93
Figure 4.63: Floor 4, Access points, Exhibitions area & Lobbies, V & A Museum...	93
Figure 4.64: Floor-1, Linear Procession, V & A Museum.....	94
Figure 4.65: Floor 0, Complex Type, V & A Museum.....	94
Figure 4.66: Floor 1, Linear procession, V & A Museum.....	95
Figure 4.67: Floor 2, Linear Procession, V & A Museum.....	95
Figure 4.68: Floor 3, Linear Procession, V & A Museum.....	96
Figure 4.69: Floor 4, Linear Procession, V & A Museum.....	96
Figure 4.70: Crowd Density for Five Case Studies.....	100

Chapter 1

INTRODUCTION

A Museum is a non-profit organization authorized to exhibit and preserve significant artworks and objects (Dillenburg, 2011). Museums recognize as a valuable point of attraction for the country and nation due to the significant role of showing what a nation has done during the intervening ages and what historical changes have occurred in the country in the history of cultural aspects of society. Therefore, museums serve to connect the county's history and future (Hooper-Greenhill, 1992). Indeed, without historical memory, it's certainly not possible for a nation to go forward. Museums are places where the memories, dreams, and even hopes of the world's people are preserved. A major duty of museums builders, curators and architects to preserve that memory (Anderson, 2003). On the other hand, nations around the world, benefit from having museums as tourist attraction points in the sense of the economic side. AECOM's and Themed Entertainment Association (TEA) provided the 2018 TEA / AECOM Theme and Museum Index informing that museums over the world receives million visitors (Chee, 2019). The importance of this building has been increased towards the countries. The architects as well as the interior architects play an important role in the construction of this public building. The major goal for the designer is to shape what the tourist perceives visually, and several studies examine it, but this research claims that not just the visual figures make the building successful, but the spatial organization as well. Study of Kali Tzortzi tilted by "Museum Building Design and Exhibition Layout: patterns of interaction" published in the year of 2007 answered How does the

architecture affect visitors' experience and the idea of 'art of exhibiting' conducts with focus on the relation between the spatial design and the displayed layout. This thesis considers the important role of circulation layout and how it is affected by building's spatial organization. Traffic spaces are considered as a connection of the bonds with other forms of space and it plays a key role in coordinating people's streams and directing visitors (Yang, Yan, 2009). So, here, the aim is to find relations between layout organization and the circulation routes that considered by how the people can orient themselves safely & get all information in the time arranged before.

The problem is that circulation layout is faced gathering and crowds' issues, which have effects on the observation process. The information provided by the museum to the visitors may not be clear & understandable. Furthermore, a less influenced and incomplete experience offered by the museum. Also, crowds cause a wasting waiting time for the visitors. Normally visitors preferred to spend it for recognizing another item. Visitors may leave to see something else and think about coming back later, but that may not be happened because of the time or lack of knowledge how to return back. The impact of having a waste time and difficulty to recognize significantly the information lead that the goal of visiting the museum is not fully achieved. This thesis is trying to answer the questions of: How the spatial organization of the museums affects the circulation routes? What Sort of layout can avoid the crowd's issues on the circulation routes? The research methodology will be both quantitative and qualitative method premised on gathering data through academic sources & examination of the chosen cases. Limitation of this study is considered according to the theme index museum, AECOM and TEA for the year 2018, the most visited museums in the world have six cases in the European cities with an adaptive reused building.

1.1 Problem Statement

The museum is a multi-cultural venue where various groups of people with various backgrounds can visit it together. Everyone has individual preferences for favorite exhibition halls or displayed objects. Therefore, an integrated experience for a visitor inside museums can be reached when she/ he realizes the whole message behind his\her interest. The building's spatial organization is one of the key parameters influencing visitors during their journey. The method of adaptive-reuse for designing museums including the layout organization, accessibility within the exhibited halls, and the relation between circulation routes and layout have an important role in the reorganization of the information provided by the displayed objects at the exhibition halls. While redesigning a historical building for its new function, the problem is that the building already has a spatial organization. However, the spatial organization of the main zones has a direct effect on the visitor's circulation example of the pathway and foyers. Designers here incur to find solutions for the crowd and gathering issues. The circulation routes between the displayed objects or between halls are essential. At this point, studying the circulation routes in relation to the general layout plan of the museums is significant. The crowds and gathering that happen during peak days on the pathways affect the observation process. Loss of information and time are the main results:

- The difficulty to reach and identify displayed objects significantly.
- Waiting time is a negative impact on the visitors' journey.
- Unclear accessible points between the halls.

1.2 Aims & Objectives

This research actualization is to study museums which are adaptively reused types located in the European cities, choosing these museums from the list of the most visited

museums in the world for the year 2018. The international users from all over the world are looking to have a well-organized experience inside the exhibition halls and between the foyers and access points. This research is aiming to figure out a spatial organization that avoids the crowd's problem, therefore, finding out circulation routes between and inside the halls that can discount the gathering issues. By studying the circulation routes in relation to the general layout plan of the museums with a focus on the exhibited areas, foyer, and access points, this study is trying to answer the following main questions:

- How the spatial organization of the museums affect the circulation routes?
- What sort of layout can avoid the crowd's issues on the circulation routes?

1.3 Methodology

The study utilizes a mixed method which is both quantitative and qualitative. The qualitative methods are a literature review and horizontal drawing analysis, the quantitative method is measuring the crowd density. Data is collected through a literature review and a profound survey on different trustworthy resources such as books, scholarly, journal articles, documentaries, and reliable web resources. The main tactic is analyzing the horizontal drawings of the six case studies throughout the perspective of the spatial organization by emphasizing the crowd issue in regards to the areas of the museums and the number of visitors. The tactics of sorting the information are using two kinds of inventory tables for each case study. The first table has a title of " introduction to the museums " Interior views of the museum are introduced. The architectural drawings along with the maps for each level have been analyzed into categories. Each floor or level of the building sorted under Indoor, outdoor & semi-out areas. The wings or parts have been also mentioned by creating a colorful legend. The last category was the crowd density calculation. The second

inventory table has the title " LAYOUT ANALYSIS OF THE MUSEUM " The focus aspects for the analysis the general layouts are the three; The Type of Layout Organization, Access points, Exhibitions' area & Foyers, lastly, Type of Relation (Pathway-Layout). The answers which have been taken from certain books mentioned on the same table which also includes a legend. The techniques of analysis the drawings done by using AutoCAD & Photoshop software. Crowds density was done through Calculator.

1.4 Limitations and Delimitations

This research does not investigate new buildings, it is conducted on the adaptive re-used buildings due to the importance of sustainability in the built environment. The European area has cities with a context that is stunning with a rich architectural and historical heritage in which museums are the indicators. According to the theme index museum, AECOM and TEA for the year 2018, the most visited museums in the world have six cases in the European cities with an adaptive reused building method. The study presents an analysis of the spatial organization of the museums in relation to the internal aspects example of circulation routes, zoning, and crowds' pattern (Figure :1.1).

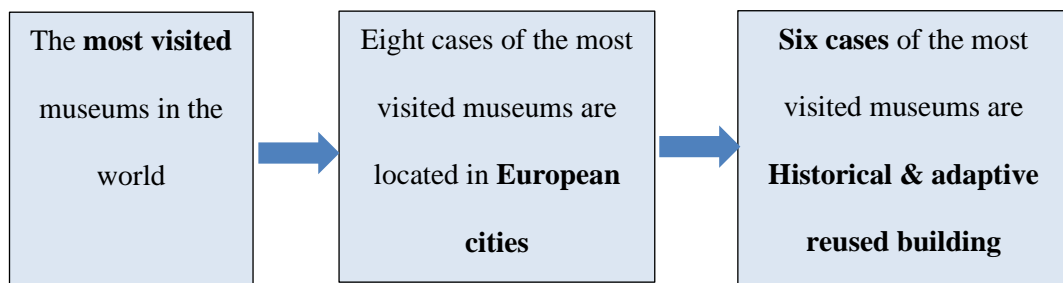

Figure 1.1: Limitation & Delimitation

1.5 Scope of the Thesis

Chapter one includes the Problem Statement, Aims & Objectives, Methodology, Limitations & Delimitations of the study. The Second Chapter is an approach for adaptively reused historic structures, then a background about Museums. Later in Chapter 3 the spatial organization in museums considering the various aspects, layout organization types, circulation, and accessibility. Chapter 4 includes analysis for six case studies through depth research based on preceding chapters of the theoretical knowledge. There are two inventory tables for each of the cases. The first table for introducing the museum and secondly analyzing it through three main aspects. Ending the chapter with the finding that is followed by a table. At the end in Chapter 5 the conclusion of the thesis exists.

Chapter 2

MUSEUMS AS ADAPTIVE REUSE HISTORICAL BUILDINGS

2.1 Historical Building

The historical building retains its architectural integrity when the existing appearance of the building was not affected by the modification over the years, and still reflect a visual sense of its original built time. For classifying any architectural building as "historic building" must-have a historically important. The importance can be extracted from one and more factors; Represented a distinguishable style of architecture. Interrelation with a significant cultural, political, or social occurrence. Attribution with a person that is essential to a culture and nation's history (W.S.H, 2020).

Douglas in 2006 discussed that a number of new projects nowadays prefer the idea of adaptation of a historic site rather than constructing a building from the zero. Modern architectural buildings are becoming much expensive while the period time passes, and has no attractiveness to the eye. Another reason for adaptation is that there's less and less space for new construction in urban parts as the years go by, which is a valid reason for an architect, who wants to contribute something to the area. It is easier to adapt the building to contemporary methods & to give it a purpose instead of destroying historic buildings to create a completely new one. The refurbishment also creates less in terms of cost and materials than new construction. Often known as sustainability lets us produce less, and save money. This brings everything from the

old to the new century, representing tradition and preserving one place 's culture too. The buildings will have a social purpose by retaining a recognizable town landmark.

This is shown that humans worldwide have a common goal for trying to protect their history. People need historic artworks to be preserved as evidence of past times. Moreover, people believed how the historical building is a bright light into the current time, representing history, then bringing it in a certain way (U.N.D.P, 1999).

2.1.1 A Notion about Adaptive Reuse Historical Buildings

It is commonly understood that several historical environments often face some kind of challenges of transformation that appear to arise either as a science, aesthetic or architectural values. It is clear nowadays that efforts of adaptive reuse are valuable in various levels. In addition, the renovation phase of existing buildings presents a significant challenge for designers as it includes implementing adaptive methods that are totally different from those used during the construction of a new building (Bonet, 2007).

The adaptability comes with specifications when a system has to be changed. The structure must be able to make these modifications and for accommodating minor improvements in its capability (Mornement, 2007). Such topics can be dealt to specifically by: Convertibility, allowing for a commercial, legal, and technical approach to the structure. Dismantle Power, example of the building may face a deconstruction in a safe & quick way. Disagreeability, coming next a phase that the building face a deconstruction, and it is recommended to either reuse or recycle the demolished parts and materials to save as much as necessary on the value for the fresh products. Expandability, allowing higher load capabilities. Lastly, Flexibility is giving

the structure extra efficiency of the spatially functional through the transfer, space arranging, & reorganization the building's design (Douglas, 2006).

2.1.2 Historical Buildings as Museums

The use of a historic building as a museum or an art gallery can be one of the most effective ways of ensuring the building's potential viability. These kinds of museums work as a proof about how display and exhibition spaces can be shaped without altering the architectural features. The criteria for effective changes in access to historic buildings can be established by many principles. Firstly, a historic analysis that help to recognize:

- Phases of building construction and subsequent alterations
- Major, minor areas of the premises
- Original building concepts, unless fully implemented
- Areas providing incentives for future changes to access.

Secondly, the phase of evaluation of possibilities which contain:

- Temporary changes, usually reversible
- External upgrades, often reversible and often intrusive (e.g. ramps, wheelchair stairlifts, platform lifts, etc.)
- Interior enhancements, which can also be unobtrusively introduced
- Entrance via an attic, basement or even a new extension Entry via a reduced threshold level at an existing door or window
- Vertical internal circulation, typically through an elevator and mostly where this can be inoffensive.
- Ways to reduce crowds' pressure from the most significant historical zones of the establishments

- Ways to expand underutilized areas and build new business opportunities (such as a store, café, meeting rooms, etc.).

Bold approaches to achieve equitable access are the most effective examples, but always with a direct and respectful response to the qualities of the historic fabric (Cave, 2007). A good example from Louvre Museums in Paris where the Pyramid as contemporary construction appears within the area of the historical building with functional reason added to the interior space (Figure 1.2).



Figure 1.2: Louvre Museums in Paris (URL 1)

On the other hand, there are several advantages of using a historic building to house for artworks and displayed objects; a project which is known for its heritage value already has a known place in the history of the society. This can be a tremendous advantage for a building that is seeking public interest in its survival. Several historic buildings have a great character which can be used for social development.

Historic buildings are often well-located near the cities center. This is a benefit in terms of attracting visitors to the site and facilitating the access. In addition, these kinds of

buildings can enhance the understanding of historical collections by providing a suitable physical or historical perspective for the collection. There is much evidence that historic buildings have solid structures and stable physical environment serving for the displayed collections. Many historic buildings, such as powerhouses and railway workshops, have such an ambience that they offer themselves to use as galleries (NSW, 2004). The Tate Modern museum located in London; UK was adaptive reuse for a power station, the following figures illustrate the idea of have such an ambience (Figure 1.3 & Figure 1.4).



Figure 1.3: Tate Modern Museum, UK
(URL 2)

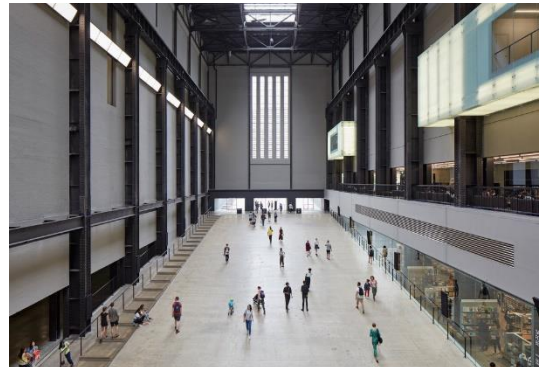

Figure 1.4: Interior view for Tate Modern Museum (URL 3)

2.2 Museums

A variety of definitions of the museums is available. The origin of the term “Museum” derives from a Greek word “Mouseion” definition of “Goddess Temple” called “Muses” explained as knowledge sense, thinking & inspiration (Günay, 2012). In the early beginning, museums work as a location where scientists and philosophers gather for educational purposes rather than an institution to preserve valuable objects (Lewis, 2019). The definition of museums nowadays is the forming kind for the world's huge exhibitions of the last century. When exhibiting objects became public, collections needed a secure place to live, and since a significant amount of money was spent on setting up the world fairs, it was not feasible and reasonable to throw away the items after the show close. Thus, museum buildings were built (Burcaw, 1983). Museums are co-educational institutions and the definition of them in an integrated form is not easy. The museum is practically a place to study, research, and enjoy house collections (Alex., 1979).

Increasing numbers of tourists worldwide reach exhibitions each year. Thus, that phenomenon has the reason why all sorts of museums are increasing around the world. Museums can lately identify as tourist attractions, restaurants, meeting places, food courts, urban regeneration, public places, house of contemporary art, and social club. The significance varies by desire (Panero, 2012).

The significant role of museums in the society has summarized with the definition from the ICOM “The international Council of Museums” As a permanent organization that works to the benefit of the community by carrying art, science, history, health, and technology collections. Works to conserve, conduct research, evaluate and display

values and culture as a whole in terms of developing aesthetic enjoyment and public education (Günay, 2012).

2.2.1 Origin of Museum

Museum's roots are date for centuries period of time. In the third century B.C., in Alexandria, Egypt the world's first museum was established, which was a significant center in the region (Figure 1.5). Museum has the function of the library, as a learning academy for philosophers worldwide; the largest educational space during the old ages at that period. However, knowledge has been preserved on rollers made of papyrus's & published by Alexander the Great. Furthermore, ancients thought about the museum as a place to collect objects like historical, aesthetic magic, and even religion that had significance for them (Berty & Costa, 2009).

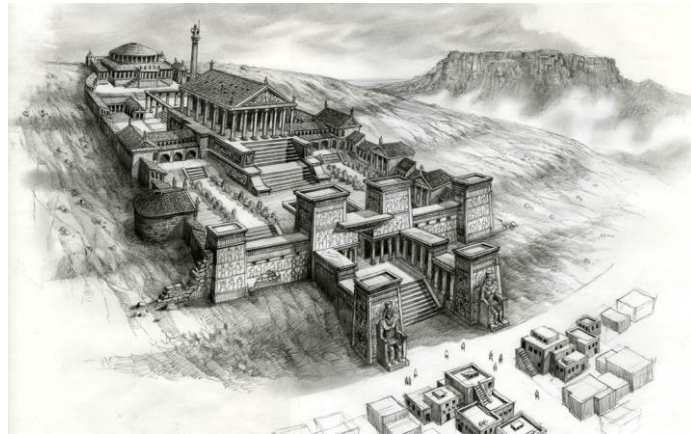

Figure 1.5: Bibliotheca Alexandrina (Ancient World Wonder, 2003).

2.2.2 History of Museum

In this section of the second chapter include a review for the most essential stages of the history of Museums.

- **Museums in Middle Ages**

The development of the idea of museums in the Middle Ages is strongly intertwined with the Christian Church which controlled intellectual life in Europe. Therefore, churches contained large libraries and were known for their scientific ventures. Furthermore, the Church received and preserved books, sacred relics, and treasures which mostly gifts from travelers (Murray, 1904). Pope Sixtus IV lately in the 15th century supervised essential art selections in Rome, Italy (Ripley, 1970).

- **Museum in Renaissance**

Renaissance writers, musicians, philosophers, and the like shaped societal mores at that time. Western thinking moved more towards an ideology that was humanist and secular. This social transition leads to a phenomenon that started to look at with scientific curiosity about the artifacts of animated existence and the material world (Murray, 1904). The Renaissance collections definitely advanced the idea of a museum. The academic interests and even the notion of preserving the past in a modern sense of heritage became evident. Such "museums," even then, was not open to the public. Museums as a result of the Renaissance were closed circle for the royal and patriarchal society that dominated art and scholarship (Lehman, 2008).

- **Museums in Fifteenth Century**

During this century in Europe, the term museum was reactivated. It was used in Florence to represent the Lorenzo de 'Medici collection. The word simply held the idea of comprehensiveness rather than a term for a building. However, it was in this century that the museums were first founded to study nature and modern sciences as powerful institutions. The first museum was founded by Pope Sixtus IV around the year 1480 as it is known today. After that interaction, three European Museums were built in 1500, 1546, and 1581 respectively (Ambrose & Paine, 1993).

- **Museum in Seventeenth & Eighteenth Centuries**

Until the 17th century, Museums hold the name “cabinets of curiosities”. This idea gave away to various styles of collections that were valued for their large variety of plants, animals, and different other types of artifacts. European countries had started to realize that nature itself provided ample variety to entertain the observer without resorting to the wonderful selections. The legendary and emblematic significance of specimens that formed part of the classical world was finished. Ashmolean Museum is considered to be the first museum open to the public that held the name "museum" The building was opened for public in 1683 (John, 2005).

In Europe of the 17th \18th century, there were earlier collections of items and show places, including public squares or forums of Ancient Rome where statues were displayed, Medieval Church Jewels (for holy and precious artifacts), and Japanese style temples where small paintings were hanged for good. As a secular environment for public interaction and education through the exhibition of artifacts, the modern museum is closely related to many institutions that emerged concurrently in Europe of the 18th and 19th centuries (Elizabeth, n.d).

- **Museums in 20th- 21th Centuries**

It was a period of considerable reassessment for museums in Europe. Governments, technical societies, and the like. The importance of museums in a changing society, and a variety of recommendations for enhancing their social sector. For museums the years immediately after World War II were an era of significant accomplishment. Museums became an educational center, a source of leisure activities, and a communication medium (Lewis, 2019).

The conventional presentations were replaced by various configurations, based on scientific and technological developments. Likewise, the number of temporary and mobile exhibits has considerably increased. Melbourne 's National Victoria Salon Museum, which has been built to be quite large. Nonetheless, it was built flexibly and the textures of the walls, floors, and ceilings can be changed in just a few hours (Anderson, 1984).

2.2.3 Types of Museum

Museums can be divided into different groups. Museum categories differ in scale, items displayed, and/or area of function, audience, or the manner they display. Science, History, and Art Museums are the most common. However, these types could be found in some museums combined (Hooper-Greenhill, 1992).

● Science Museums

The Science Museum has environments that existed as a depository for vast collections of organisms from plants and animals to geological materials and human artifacts. The Ashmolean Museum was the very first public science museum, established at the University of Oxford in 1683 and built to try educating and entertaining the British public. In 1969 there appeared two distinct types of science museums; Traditional Museum of Natural Science, with its specimens for observation, & the Museum of Science that combined Science and Technology with interactive activities. While many institutions of science and technology are involved not in research but in the hands-on interpretation of science. The Traditional Museum of Natural Science is actively active in science and selection care, and are keepers for the natural wonders of the earth (Nicholson, 2020).

- **History Museums**

History Museums present various periods of history & collect millions of items and documents in enormous buildings, on another hand, History museums found as small and focused on one period of the history, one region of the country or one person or set of people. The role of this kind of museum is to arrange exhibitions and activities that cover countless subjects. The recurring factor is to use objects to educate people about history, to use the past to share information about how to effectively experience the future. The staff of the History Museums also have expertise in museum studies or education in history. Under the category of " Historical Museum " types such as; Historic Houses, Historical Societies, & Living History Sites (VAM, n.d).

- **Art Museums**

Generally, the museum of art preserve compilations consisting of painter's work, portraits, drawings and sculpt work. They may maintain clay, stone, fabric, & golden or silvery objects from various cultures, in addition to art collections. They also plan extracurricular events to support public education services. For example, weekly or monthly lectures in galleries are suitable options for adults while some painting classes are available for teenagers (Morris, 1962).

- **Geological Museums**

Museums of Geology display life on Earth, from volcanoes to fossils. Geological museums have collected and established expositions of fossils, rocks, petrography and meteorites over the centuries (URL4).

Chapter 3

SPATIAL ORGANIZATION

In this chapter, space organization and circulation issues will be introduced and discussed for general architectural spaces, and within the chapter, more focus will be on Museums, “space functions, circulation and relation between circulation pattern and layouts organization.

3.1 Spatial Organization

Spatial organization is the interaction between the spaces that create up the building. Spaces that have different goals and objectives come together in a construction project. In this sense, spaces are comparable or similar in most buildings, except there are spaces that differ from the rest. Such differences define a hierarchy, and its function determines any space within the structure (Brebbia & Hernández, 2015). A classification for organization types of architectural buildings was illustrated by Ching as; Centralized Organisation, Linear Organisation, Radial Organisation, Clustered Organisation, and Organization of Grids.

- **Centralized Organization**

A centre, dominant space which consists of a number of secondary spaces. Secondary spaces can vary in form or size from each other to respond to specific functional requirements, express their relative importance, or acknowledge their surroundings. Innately, a centralized organization is non-directional in shape (Figure 3.1).

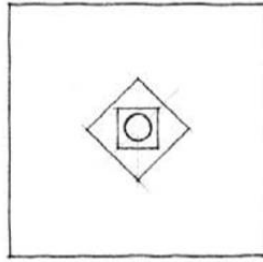

Figure 3.1: The central organizing space. (Ching, 2007)

- **Linear Organization**

A linear organization basically contains a series of spaces. These spaces can either be directly related to each other or can be connected through a separate linear space. Linear organizations articulate a path because of their characteristic length and indicate flow, extension, and development. Furthermore, this structure is inherently versatile and can react readily to different site conditions. for example, it can adjust to topographical changes; navigate around a body of water or a stand of trees (Figure 3.2).

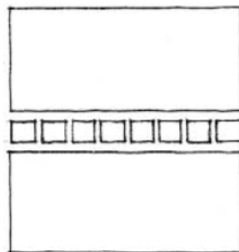

Figure 3.2: Linear Organization (Ching, 2007).

- **Radial Organization**

The radial organization mainly a combination of both from which centralized and linear organizations. This acts as a central dominant space, from which a variety of linear organizations spread in a radial manner. A radical organization's central space is typically normal in shape. However, the radiating arms that vary from each other to satisfy the individual purpose and context needs (Figure 3.3).

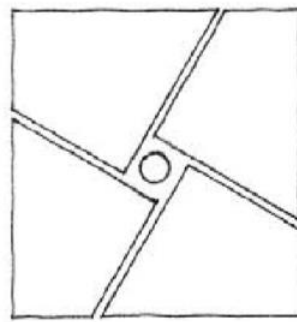

Figure 3.3: Radial Organization (Ching, 2007).

- **Clustered Organization**

This type of organization has spaces clustered by distance or common visual characteristic or relationship sharing. Clustered spaces may be built around a point of entry into a building or along the direction of travel. It is possible to use symmetry or an axial condition to reinforce and unify parts of a clustered organization. This organization is close to that of a centralized organization, but the compactness and geometrical regularity of the latter is missing (Figure 3.4).

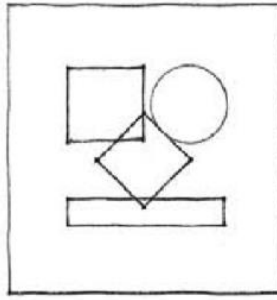

Figure 3.4: Clustered Organization (Ching, 2007).

- **Grid Organization**

A grid organization consists of types and spaces for which a three-dimensional grid pattern or field governs positions in space and relationships with one another. repetitive, and modular units consider as the clear sign of this type. The grid pattern is projected into the third dimension and is converted into a series of regular, linear units of space. The organizing power of a grid is the product of its pattern's regularity and consistency, which pervades the elements it organizes. A grid can convert its image through its field from a pattern of dots to lines, planes, and finally volumes (Figure 3.5) (Ching, 2007).

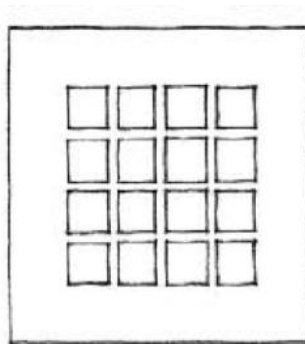

Figure 3.5: Grid Organization (Ching, 2007).

3.2 Spatial Circulation

Spatial circulation is the architect's predefined way or direction to establish a hierarchical connection for all of the spatial components in a building. Although the spatial organization is much more about the association of spaces, the relationship between pathways and spaces is about circulation. To understand spatial circulation, consideration of the starting point, the architecture, and the architectural meaning of the route are important (Brebbia & Hernández, 2015). Ching (2007) describe the circulation as "perceptual thread" that binds a building's spaces, or any set of indoor or outdoor spaces, together, and categorized the aspects that has a direct effect on the user's perception of the space & structures:

- Approach
- Entrance
- Configuration of the path
- Path–space relationships
- Form of the circulation space

3.3 Museums as a Space

Generally, in the process of designing a museum and through the perspective of a visitor the most essential functions within the internal space are contained of three main zones; Exhibition Space, Traffic Space, and Rest Space (Henderson, 2001).

- **Exhibition Space**

Exhibit designing is the procedure of creating an exhibition-from the stage of concept to the 3D physical display. It is an ever-evolving field, drawing on innovative, imaginative, and realistic approaches to the challenge of creating communicative spaces in a three-dimensional space that 'tell a story (David, 2006). Bedford in the year

of 2001 stated that the narratives seem to be the most basic way we know, includes the user-centric; start (introduction), midst (body), & a closure (Conclusion), where users with the decisions considered the focus of the designing phases (Kelly, 2010). Furthermore, common methods of organizing an exhibition hall within the showcase are along the wall or in the central area of the room. Particularly, in the exhibition room, the two sorts of objects examples of Plane Exhibits and Small 3D-Objects are organized towards the walls. However, the larger Precious 3D-Objects can be displayed on a special stand (Ding, 2010).

- **Traffic Space**

Entrance, Ramp, Escalator, Stair, and lift are elements that considered a part of the Traffic Space of the museums. In another word, these are tools for linking exhibitions halls. Another benefit is to guide visitors & stream the people. Traffic space is the area that contains all gathering points (Li, Wei & He, 2013). Later More discussion about these elements in this chapter.

- **Rest Space**

Generally speaking, types of Rest Space are differentiated in the museum, which can primarily be categorized into 5 types, as shown in the following details.

1. **Specialized Space of Rest** which is mostly situated in the area where the crowd flow is concentrated and the spatial overlap. This area offers visitors a chance to chat with each other and can have a break.
2. **Rest Space along the Aisle** is also designed to encourage visitors to pause and rest whenever they choose. Normally, located when a double stream intersection and

spatial conversions happen, such as a corridor, aisle, and staircase. For a brief description, it is the space where simply arranging seats along the wall in the aisle will fulfill the requirement for rest.

3. **Utilizing Remaining Rest Space** where is the use of available space to set up small jagged and interlocking as a resting area. A small space corner can be organized as a retail section, providing audiences with drinks or with basic food. It is highly recommended that this space be refined and detailed with esthetic appreciation.
4. **The Rest Area Linked to other Functional Spaces** is for service provision. The rest space here maybe around or beside the elevator. this resting space provides ease and comfort, however, it doesn't offer many seats in that zone
5. **Rest areas set inside the exhibition hall:** Although it is not popular to see such resting areas, in many exhibition museums we can find examples. It contains furniture and coffee tables in its exhibition room to provide the visitors with a specific spot for a break after a long walk (Li, Wei & He, 2013).

3.3.1 Circulation of Museum Space

Designing the interior circulation of a museum defined as how the users perceive the 3 dimensionalities of a building with complete respecting of sequence, time, and space through the movement of visitors' bodies (Hsu, 2004). Additionally, Stephen (2009) raised up questions under the term "interior circulation" on how visitors' journey through the facility. Which paths do they take? Circulate tourists the way designers designed it? Do the visitors skip the main exhibits due to the facility's architectural design? What path do visitors take when they arrive at points of selection? (Elottol & Bahauddin , 2011)

Circulations are the whole walking spaces throughout all the floors, both physically bounded by partitions or not. It is necessary for physical access to any spatial classification. Horizontal and Vertical circulation, public halls including, but not limited to; exhibition spaces, entrance foyers, elevator lobbies, tunnels, bridges, and the footprint of elevator shafts, escalators, and stairways on each floor. Also, have the corridor which either cordoned with material and sometimes without (Black, 2005).

There are two main types of interior circulation. They are horizontal circulation and vertical circulation. Vertical and horizontal circulations are considered as part of the form of the circulation space that affects generally the visitors' movement within museums.

- **Vertical Circulation**

Vertical circulation explains how visitors make their way through the building by the circulation components, between various floors and levels. It is basically all the walking areas and mechanical equipment designed on all floors of a building needed for vertical physical access to certain areas like staircases, ramps, elevators, and escalators (Beirne, 2003).

- **Horizontal Circulation**

A horizontal pathway explains how people use mobility components to make their way through the facility on the same level. It is basically all walking spaces on all floors of a building necessary for horizontal physical access to certain rooms, such as corridors, lobbies, verandas, porches, doors, foyers, and balconies (Beirne, 2003).

3.3.2 Circulation Routes (Pathway) and Layout Organization Relations

As discussed before in the chapter 3 there are five types of layout organization Ching categorized five types of architectural spatial organization. Indeed, there is a critical relation between circulation routes (pathway) and the layout organization of the Museums. Bitgood (1988) stresses the importance of designing pathways in museums. Notes that the interior design of the museums and the layout of the building's exhibits, which limit the movement of visitors, can decide how visitors communicate with display items. The way the route is designed is therefore the main issue of the interior design of the museums. These days, it is becoming a fact that the interior path is the critical point for the design of exhibitions and museums. At the same point designers must realize that all components of circulation and pathway are relevant, and in the phase of museum design, the pathway is the main key to decisions on how to present

and show the collection for visitors. In the year 2009, the International Council of Museums claims: ultimately the design of the pathway is important for moving visitors through the museum (Elottol & Bahauddin, 2011). The message behind each museum is created by the space movement. Pathway patterns via the exhibition space participate in forming the visitor's perceptions and shape their understanding. The spatial organization focused on access and visibility patterns. When visitors pass through the museum and through its display areas, experience unfolds based on the scope and order of exhibits and components of the exhibition (Wineman, 2009). The main function of the pathway is to link the exhibition halls and assist the visitor to move through it. Simplicity and Continuity are the most essential features for designing the pathway. All information through the exhibition halls should be given to the visitors. The typology of the pathway is depending on how the information or objects are displayed on the pathway. Four options are categorized; one-sided, two-sided, a combination of these two types in one, and finally, the displayed objects located in one side of movement direction (Nikolo, 2018).

Matthews, in his book “Museums and Art Galleries (Design and Development Guides)” describes the pathway in museums design within the organization of the exhibition halls as; Loop, Linear procession, Core, Labyrinth, and Complex and throughout the figures (Figure 3.6- 3.10).

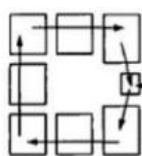

Figure 3.6:
Loop

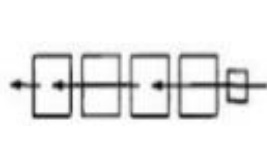

Figure 3.7:
Linear
Procession

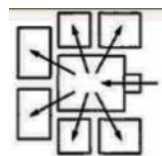

Figure 3.8:
Core

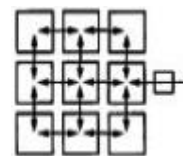

Figure 3.9:
Labyrinth



Figure 3.10:
Complex

Chapter 4

CASE STUDIES AND ANALYSIS

4.1 Overall Research Methodology

This study based on the framework of a mixed-method which is both quantitative and qualitative. The main tactic is analyzing the horizontal drawings of the case studies throughout the perspective of the spatial organization by emphasizing the crowd issue in regards to the areas of the museums and the number of visitors. Techniques of analysis of the drawings done by using AutoCAD & Photoshop software. Crowds density was done through Calculator. All the information has been sorted on two inventory tables which are explained in detail in the same chapter. The limitation leads to analyzing six case studies. The reasons behind considering these cases; Firstly, its historical context as the adaptive-reused buildings in the European area. The research trying to study the interior space which optimum millions of visitors yearly, therefore, according to the theme index museum, AECOM, and TEA for the year 2018, the most visited museums in the world and they correspond with the limitations of the study have been chosen. The case studies are listed below:

1. Louvre Museum, Paris, France
2. The Vatican Museum, Vatican City, Italy
3. British Museum, London, UK
4. The National Gallery, London, UK
5. Natural History Museum, London, UK
6. Victoria & Albert Museum, London, UK

4.2 Data Collection and Data Analysis Methods













Generally, research was conducted through a survey of the literature, articles, drawings, documentaries, and books. The data collected for the necessity of both architectural drawings and visitors' maps that have been published by the official websites for Museums, Furthermore, The main three sources for the collection the data was first, the book of Francis D.K. Ching "Architecture Form, Space, Order" Secondly, Matthews, in his book "Museums and Art Galleries (Design and Development Guides), along with the article of Yang Hairong, Yan Lei in 2009 under the title of Museums traffic and etc. Thirdly, the crowd's density calculation done depends on the rule: the number of people per square meter for a standing crowd and a moving crowd which is a study for Professor. Keith Still in 2019. Data analysis done for the horizontal drawings of each floor or level in the case studies. The Inventory tables were the tactic to present and sort the information. Each of the case studies has two kinds of inventory tables. "Introduction to the Museum" & "Layout Analysis of the Museum". The first table introduces the interior views & the architecture drawing along with the maps for each level or floor of the museum. For every horizontal drawing, an analysis for indoor, outdoor & semi-outdoor has done, furthermore, a colorful legend clears the parts or wings of the Museums. The last information is for the Crowds density. The second table analysis the drawings through three main aspects: "Type of layout organization", "Access points, Exhibitions area, Foyers", and the last aspect is defending the "Pathway -Layout Relation". All of the findings have been sorted in tables. Following are the two tables used as "Inventory Tables".

4.2.1 Inventory Table: Introduction to the Museum

For each one of the six museums the "Introduction Table" has the information about the name of the museum, interior views, and both architectural & maps drawings for

every floor and level. These levels have been sorted under the type of “outdoor, indoor, semi-outdoor”, Furthermore, each level has various wings or parts that were mentioned in the table. And the last information is about the crowd’s density that the calculation done depending on the rule: the number of people per square meter for a standing crowd and a moving crowd (Keith, 2019) (Table 4.1).

Table 4.1: Inventory Table: Introduction to the Museum

NAME OF THE MUSEUM, LOCATION			
INTERIOR VIEWS			
Architectural Drawing & Map		Building (outdoor, semi outdoor, indoor)	Parts \ Wings
Floor, architectural drawing	Floor, Map	 In door  Semi-outdoor	
Floor, architectural drawing	Floor, Map	 In door  Semi-outdoor	
Floor, architectural drawing	Floor, Map	 In door  Outdoor	
Floor, architectural drawing	Floor, Map	 In door  Semi-outdoor  Outdoor	
Floor, architectural drawing	Floor, Map	 In door  Semi-outdoor  Outdoor	
Crowd Density			
Average visitor per aday is :	Totally Area : m2		Year of 2018

4.2.2 Inventory Table: Layout Analysis

The table of layout analysis includes three main aspects. “Layout Organization type”, “Access Points, Exhibition Zones, Foyers” and the last aspect is “Type of Relation between (Pathway-Layout)”. Furthermore, there is a legend for reading the drawing. The layout analysis tables present three drawings for each floor or level and the result (type). These aspects differ through the levels and for discussing them this study used the following references. The book “ARCHITECTURE Form, Space, & Order” that sorted the layout organization types as: Centralization, Linear, Radial, Cluster & Grid. Secondly, Access points, Exhibitions area, Foyers. Here, the focus will be on how the visitor can reach the exhibited halls horizontally using the lobbies and foyers and vertically through the access points. Finally, Matthews (1991) lists: Linear Procession, Loop, Core, Labyrinth & Complex for classifying the relationship between configuration pathway & layout organization (Table 4.2).

4.3 Case Studies

The six case studies selected as an adaptive-reuse type of building and for its number of visitors over the world. Then, a comparative analysis of the spatial organization gives information about their differences and similarities under the finding title.

4.3.1 Louvre Museum, Paris, France











- **Historical Background of the Louvre Museum**

The Louvre Museum is the largest museum for art in the world, and a historic monument located in Paris, France, stands as a landmark of the city. The area of the building is 73 square meters, includes nearly 38,000 objects & artifacts from the prehistory to the 21st century (Kit, 2014). In 2018, the Louvre received 10.2 million visitors, making it the most visited museum in the world as per the theme index museum AECOM and TEA. Philip II in the late 12th to 13th century built the Louvre castle where the remnants appear in the basement of the museums nowadays. The second function for the Louvre was in 1546 as a primary residence for French Kings after an urban expansion that led the castle to lose its defiance function (The Editors of Encyclopedia Britannica, 2020). In August 1793 and during the French Revolution the National Assembly opened the Louvre as a museum to the public. In the ages of Napoleon, the museum expanded the collections because of the spoils from Belgium, Italy, Prussia, Austria and Egypt. The Louvre continued to expand, after Napoleon. The Louvre complex was completed in the mid-19th century under the reign of Napoleon III (Szalay, 2018).

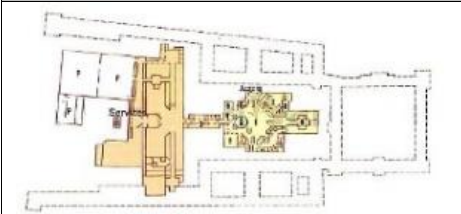
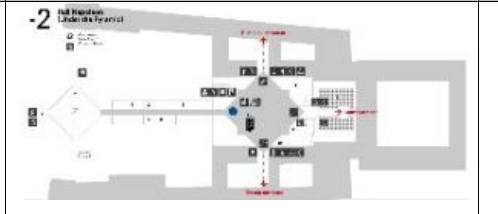
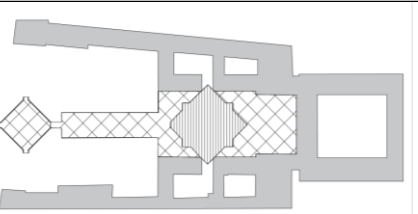
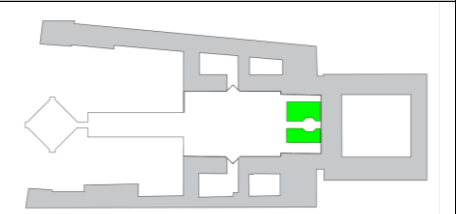
- **Architecture Drawing\ Maps & Crowd Density of Louvre Museum**

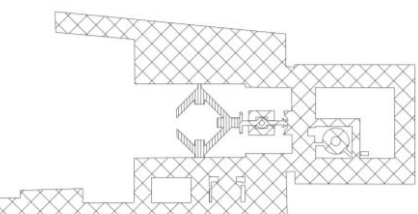
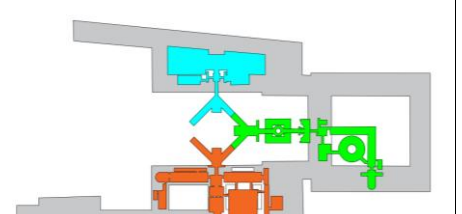
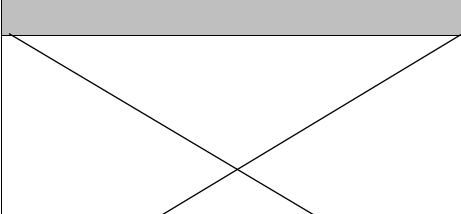
The architectural drawings along with visitors' maps of Louvre Museum show 5 floors of the buildings (-2, -1, 0, 1, 2) introducing three wings (Sully, Richelieu, Denon). Floor -2 has only part of Sully wing and all of its zones under the type of indoor, except the space under the pyramid is semi-outdoor area. Floor -1 has all the three wings designed in the indoor area. Floor 0 the ground level of the building has a full indoor in Richelieu wing with limited of outdoor in Sully and Denon side of the building. Floor 1 has all of the three wings in indoor areas with some semi-outdoor space in Richelieu wing and an outdoor area near the Sully & Denon. Floor 2 includes two indoor wings Sully and Richelieu with limited spaces of both semi-outdoor & outdoor areas. Here average 28000 people per day on the total area 60600 m², the density results as 0.46 for per meter square the inventory table: Introduction to Louvre Museums (Table 4.3).

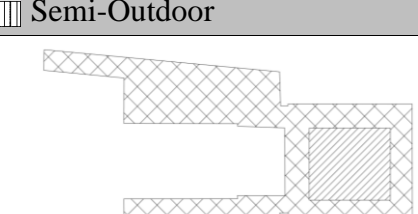
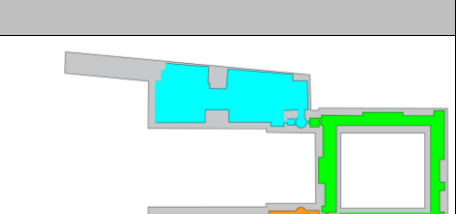
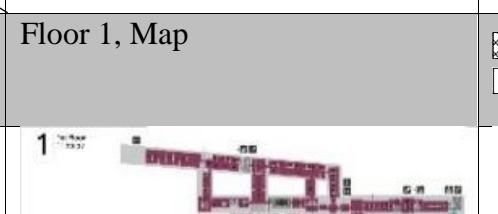
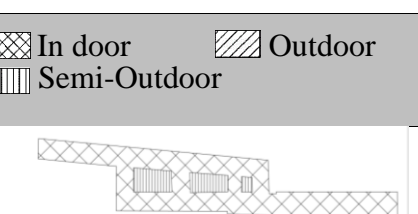
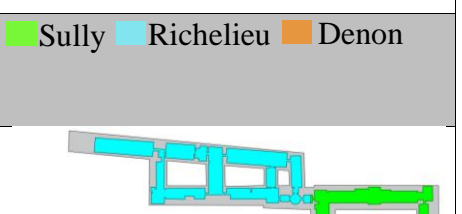
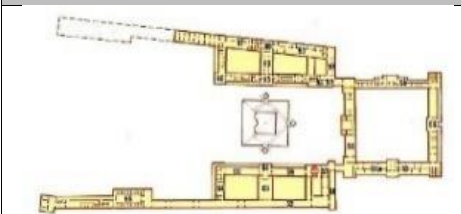
Table 4.3: Inventory Table: Introduction to the Louvre Museum

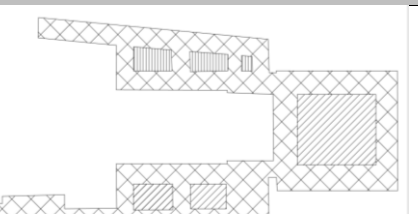
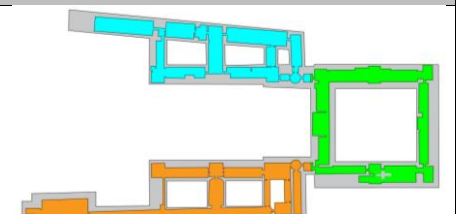
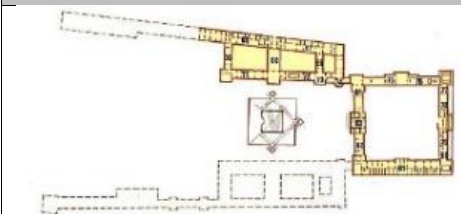
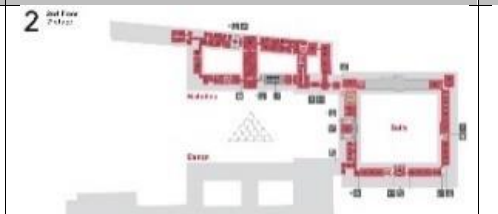
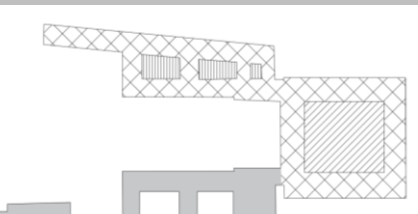
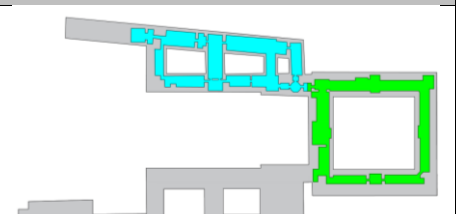
LOUVRE MUSEUM, PARIS, FRANCE			
INTERIOR VIEWS			
			
Architectural Drawing & Map		Building (Outdoor, Semi-outdoor, Indoor)	Parts \ Wings (Sully, Richelieu, Denon)
Floor -2, Architectural Drawing	Floor -2, Map	☒ In door ☒ Semi-Outdoor	■ Sully
			
Floor -1, Architectural Drawing	Floor -1, Map	☒ In door ☒ Semi-Outdoor	■ Sully ■ Richelieu ■ Denon
			
Floor 0, Architectural Drawing	Floor 0, Map	☒ In door ☒ Outdoor ☒ Semi-Outdoor	■ Sully ■ Richelieu ■ Denon
			
X			
Floor 1, architectural drawing	Floor 1, Map	☒ In door ☒ Outdoor ☒ Semi-Outdoor	■ Sully ■ Richelieu ■ Denon
			
Floor 2, Architectural Drawing	Floor 2, Map	☒ In door ☒ Outdoor ☒ Semi-Outdoor	■ Sully ■ Richelieu
			
Crowd Density			
Average visitor per aday is : 28000	Totally Area : 60600 m2	0.46 per meter sqaure	Year of 2018

- **Aspects of the Study**

The architectural drawings along with maps have been analyzed throughout certain aspects: Layout organization, Accessibility & Zoning, and Relation between (pathway-layout), for each floor of the Louvre museum and sorted in tables.

- **Layout Organization**

Floor -2 shows a linear type of organization (Figure 4.1). This floor plan organized the essential functions along the length and offset from middle pathway.

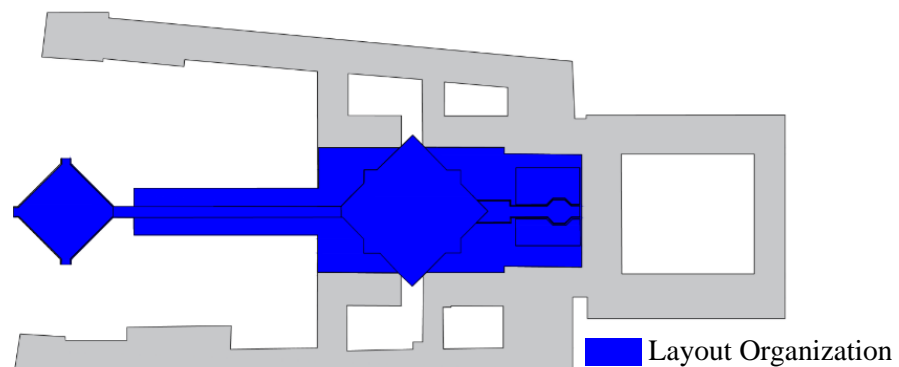

Figure 4.1: Floor -2, linear type of organization, Louvre Museum

Floor -1 has a foyer in the centre of the space with three main zones created the exhibited areas distributed around the centre. All of these spaces have linear organization connected with to the central, for that combination the floor -1 has a radial type of layout organization (Figure 4.2).

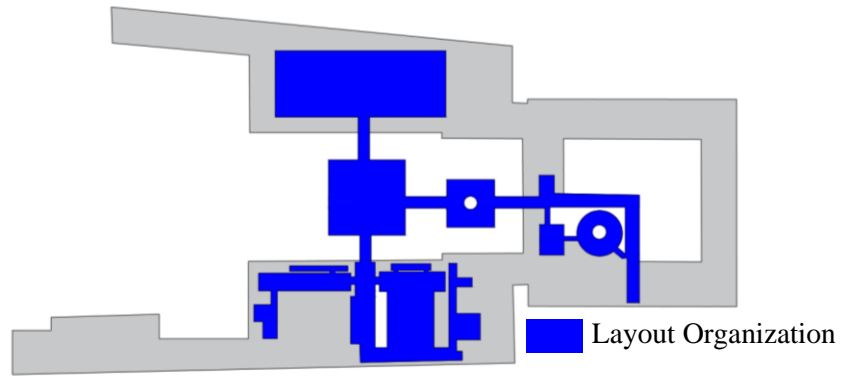

Figure 4.2: Floor -1, Radial type of organization, Louvre Museum

In Floors (0, 1, 2) the exhibition halls organized with the idea of linking zones with mutual zones and these zones show a linear method to link different spaces in form, size & shape. These all have a similar function grouped and repeated in a linear sequence in the three wings. Throughout the three levels the linear organization enclosed a semi-outdoor & outdoor area as explained in the introduction table (Figures 4.3, 4.4 & 4.5).

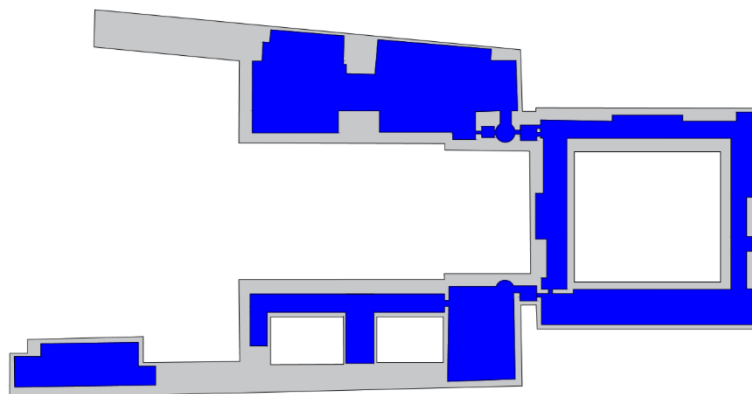

Figure 4.3: Floor 0, linear type of organization, Louvre Museum

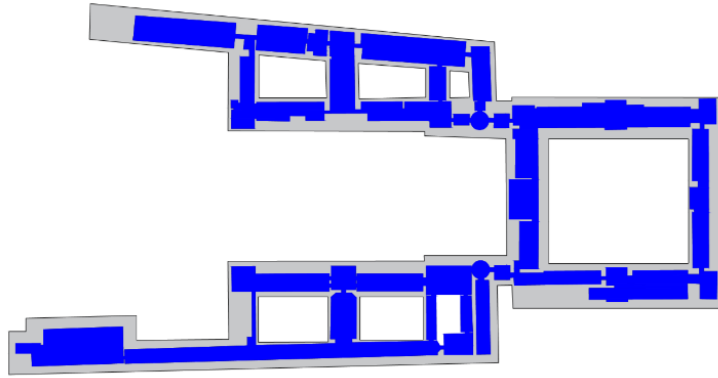

Figure 4.4: Floor 1, linear type of organization, Louvre Museum

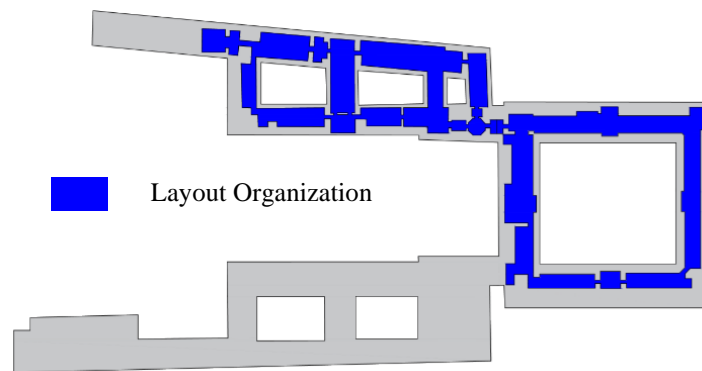

Figure 4.5: Floor 2, linear type of organization, Louvre Museum

➤ **Accessibility (access points) and Zoning (exhibited space & foyer).**

Floor -2 has access points from the exterior areas of the museum and two main foyers appears in yellow color. The left side has two access point , parking area (P) & metro side (M) .The opposite foyer has various access points leading the visitor to floor -1: three escalators (E) each one for different wing, two stairs (S) and two lifts (L) .The floor also has services zones like library, tickets section, toilets, souvenir shop and the floor ended with exhibition halls as part of Sully wing appears in red color, visitors can reach it throughout one main pathway coming from the foyers in the left side (Figure 4.6) .

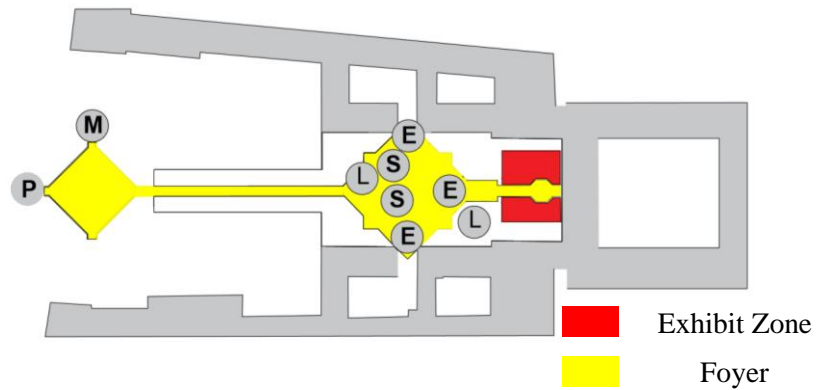

Figure 4.6: Floor -2, Access points, Exhibitions area & Foyers, Louvre Museum

Floor -1 has in the centre a foyer leads to the three wings and also connected with the lower floor. The access points have various types stairs (S), lifts (L) & escalator (E). All are distributed within the exhibited areas allowing the visitors to move vertically throughout the levels (Figure 4.7).

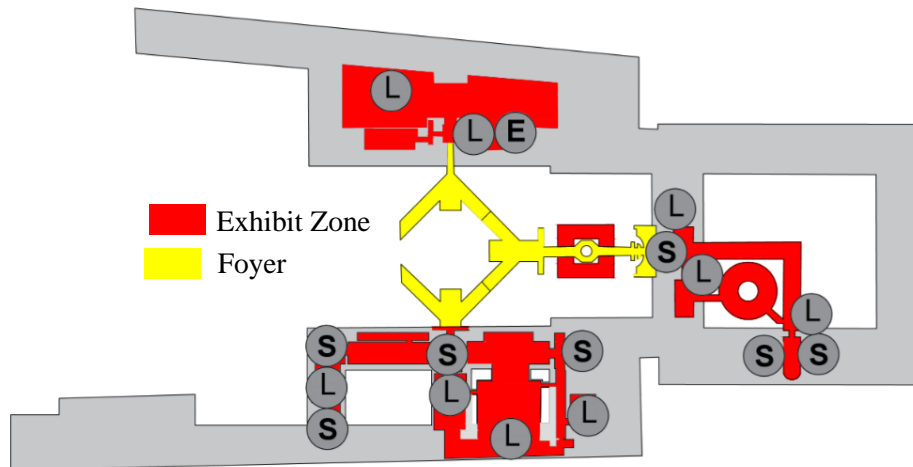

Figure 4.7: Floor -1, Access points, Exhibitions area & Foyers, Louvre Museum

Floor 0 & Floor 1 have all the access points: stairs (S), lifts (L) & escalator (E). The visitors for their vertical circulation shall use them. These floors have no special grouping zones, instead of that each one of the access points can work as a small lobby or foyer. The exhibited area has been increased in floor 1 comparing to floor 0,

however the opposite happens to the number of access point, which was less in floor 1(Figure 4.8 & 4.9).

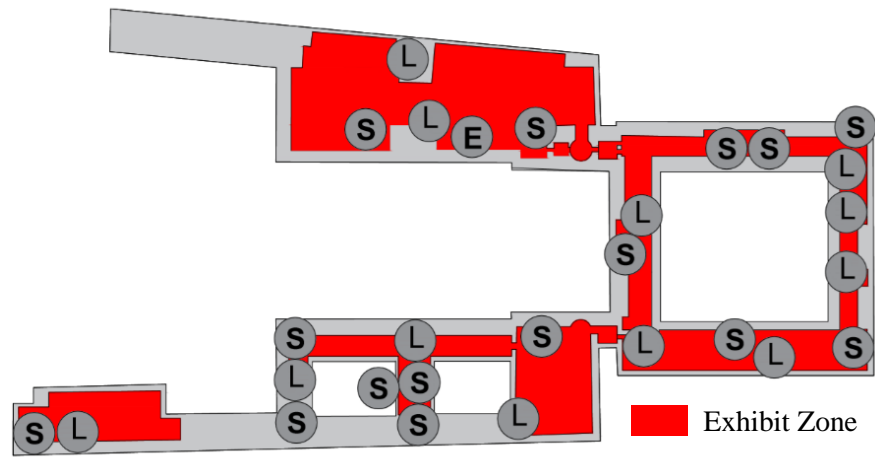

Figure 4.8: Floor 0, Access points, Exhibitions area & Foyers, Louvre Museum

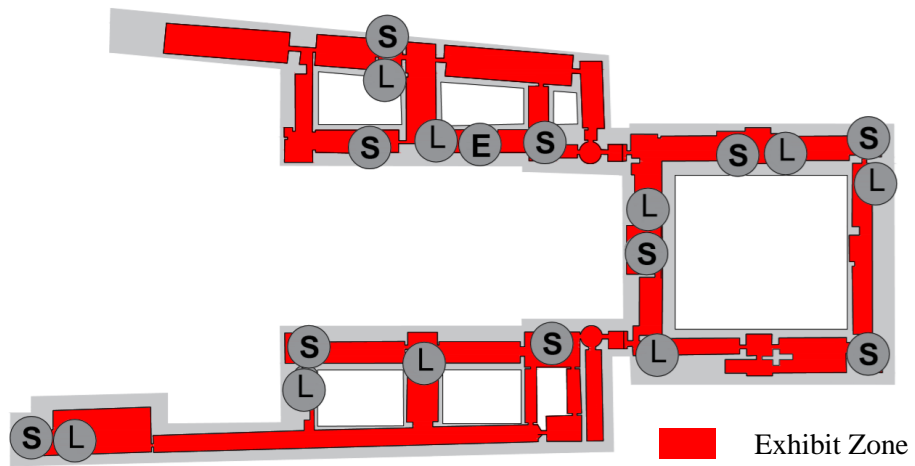

Figure 4.9: Floor 1, Access points, Exhibitions area & Foyers, Louvre Museum

Floor 2, the highest level of the Louvre Museum. The exhibited areas have two wings only. The available access points are: stairs (S), lifts (L) & escalator (E) although, the floor 2 has a less number than other floors (-1, 0, 1). Here, no any specific zone for gathering people, the space surrounded the access points can work as foyer or lobby (Figure 4.10).

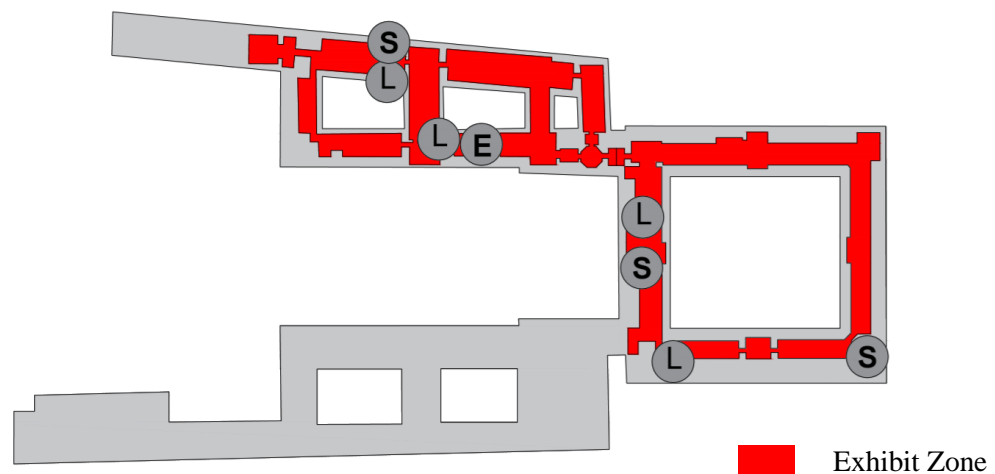

Figure 4.10: Floor 2, Access points, Exhibitions area & Foyers, Louvre Museum

➤ **Pathway-Layout Relation**

Entering the Louvre Museum building happens through floor (-2), Metro side works as Entrance & crossed with a Parking side Entrance, that create gathering area for the visitors in a foyer. A straight length pathway passed through the space lead to the second foyer which has various access points, and finally lead to Sully wing which stand offset of the main pathway. In this floor (-2) the relation is “Linear Procession” (Figure 4.11).

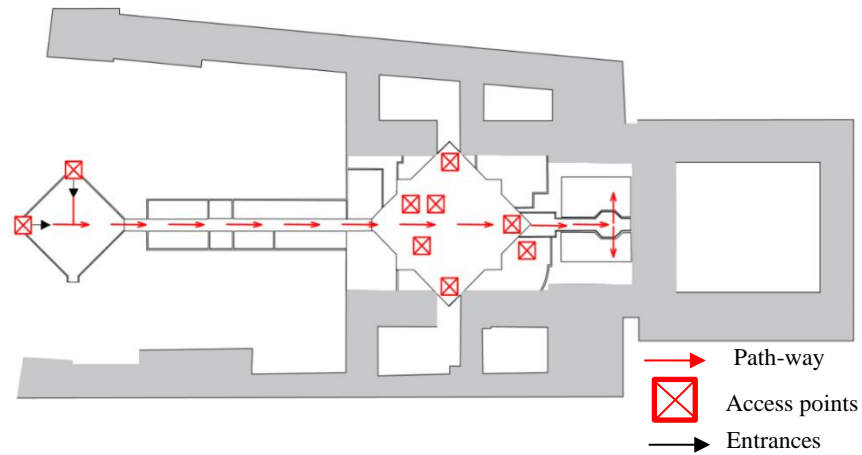

Figure 4.11: Floor -2, Linear Procession, Louvre Museum

Floor -1, has a foyer works as a start point for the visitors to reach the three wings. The pathway has a “Core” relation with Radial layout organization; however, the same level has various access points also works as start point for another circulation journey (Figure 4.12).

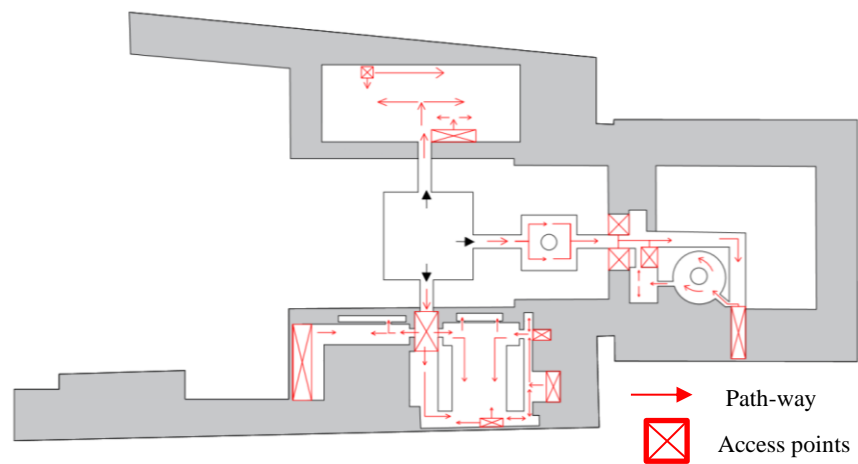

Figure 4.12: Floor -1, Core, Louvre Museum

Floors (0, 1, 2) all has the linear procession as a result for reflecting the same type of linear organization, no any specific space works as a foyer but the access points work starting points instead (Figure 4.13, 4.12 & 4.14).

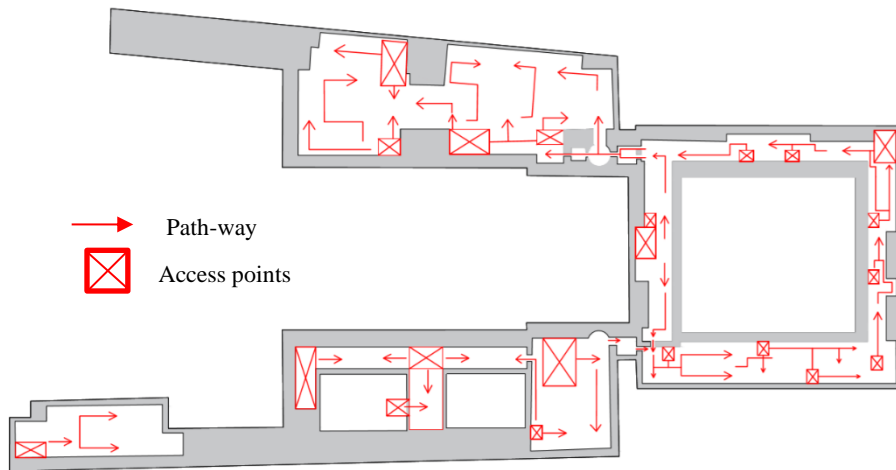

Figure 4.13: Floor 0, linear procession, Louvre Museum

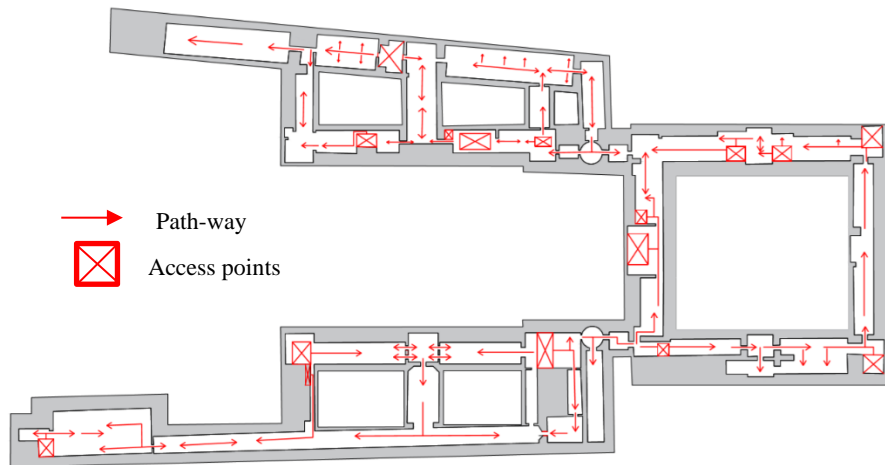

Figure 4.14: Floor 1, linear procession, Louvre Museum

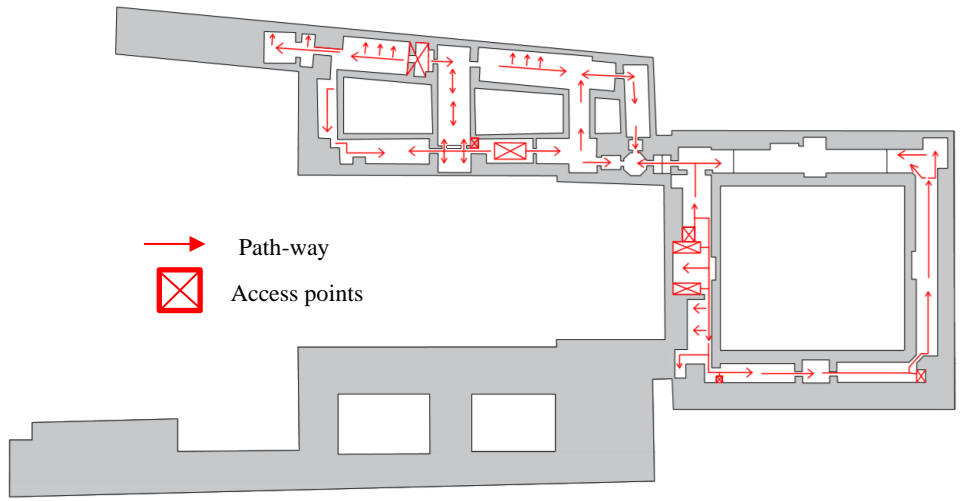

Figure 4.15: Floor 2, linear procession, Louvre Museum

➤ **Summary of Louvre Museums Layout Analysis**

The spatial organization of Louvre Museum has similarities & differences between the floors. Type of organization was mostly “Linear “for the whole layouts expect “Floor -1”. Entrance of the Building was from floor -2 which has two foyers, Floor -1 also has one foyer in the center. Moving vertically throughout the access points distributed within the five floors: Stairs, Lifts & Escalators which also worked as a starting points for the visitor’s journey. Finding that the relation between pathway & layout is “Linear Procession” expect a “Core” type of relation in Floor -1. The inventory table of Layout Analysis of Louvre Museum Five Floors (Table 4.4).

Table 4.4: Layout Analysis of Louvre Museum Five Floors

LAYOUT ANALYSIS OF LOUVRE MUSEUM FIVE FLOORS		
Layout organization	Access points, Exhibitions' area & Foyers	Type of relation (pathway-layout)
Floor -2, Linear Organization Type		Floor -2, Linear Procession
Floor -1, Radial Organization Type		Floor -1, Core
Floor 0, Linear Organization Type		Floor 0, Linear Procession
Floor 1, Linear organization Type		Floor 1, Linear Procession
Floor 2, Linear Organization Type		Floor 2, Linear Procession
	Exhibit Zone Foyer Stair Lift Escalator Metro Parking	Path-way Access points Entrance

4.3.2 The Vatican Museum, Vatican City, Italy

- **Historical Background of the Vatican Museum**

The Vatican Museums in Rome is an incredible combining of 26 museums located in the Vatican Palaces, mostly of art, paintings, and sculptures. In the 16th century was the beginnings of the Vatican Museums, when Pope Julius II founded a "Classical Sculpture State" and decided to keep in the Octagonal Courtyard. In the second half of the 18th century, Pope Clement XIV and Pope Pius VI supported the first actual museum, planned as a formal exhibition of artworks open to the public, this is why this gallery is now known as the "Pius-Clementine Museum". The architectural history of the Vatican Palaces, also popularly known as the Apostolic Palace, begins in the ninth century when a castle was built near the basilica of Saint Peter. In the Middle Ages, the fortified town was expanded, but the present form of palaces was shaped during the Renaissance and the Baroque periods, by efforts of architects such as Baccio Ponte (Bianchini, 2019). In 2018, the Vatican Museum received approximately 6.7 million visitors, is ranked fourth in the list of most visited museums in the world, as per the theme index museum AECOM and TEA. It's historical context & the location in the European area make it the second case study for this thesis.





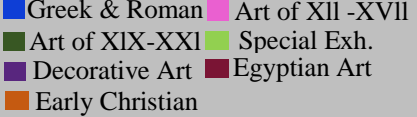
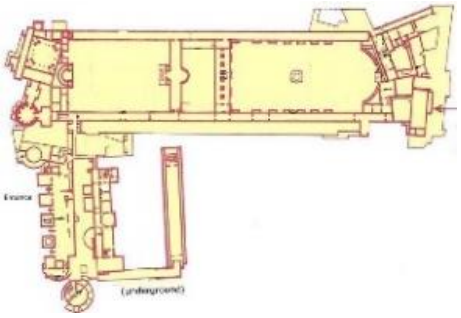
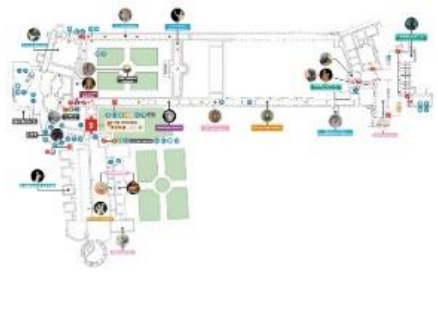
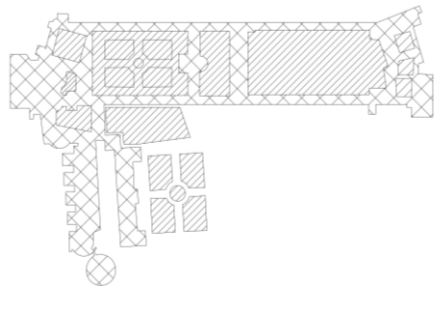
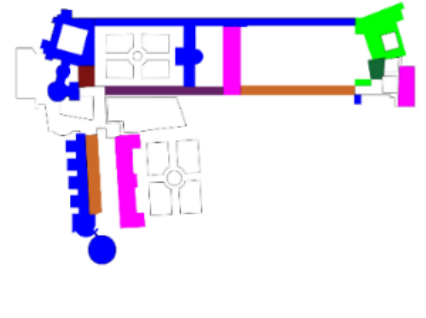
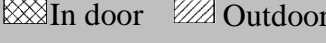

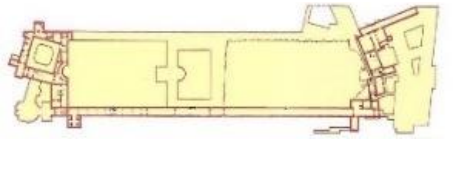

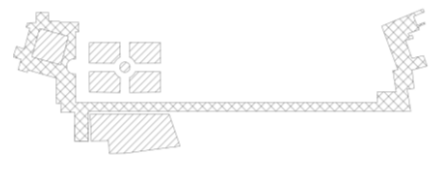
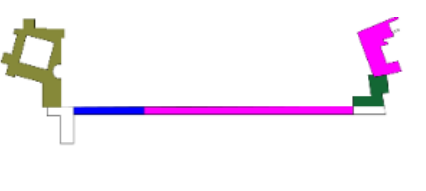

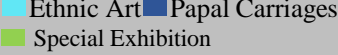
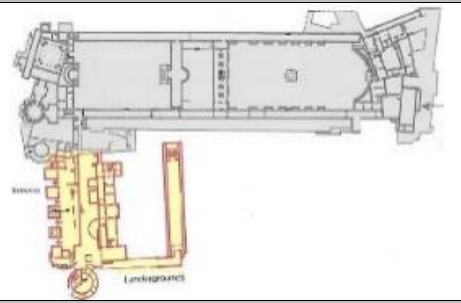

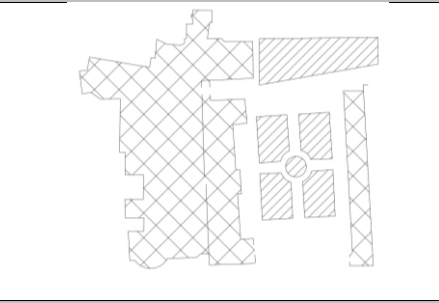
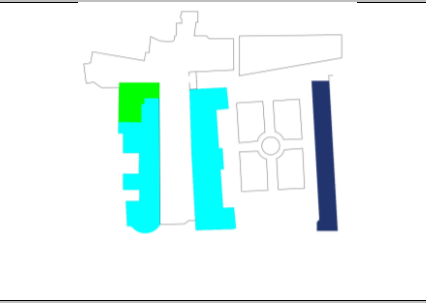

Figure 4.16: Vatican Museum (URL 5)

- **Architecture Drawing and Maps of Vatican Museum**

The architectural drawings along with visitors' maps of Vatican Museum describe that there are 3 floors of the buildings opened to the visitors: Lower Floor, Upper Floor & Basement Floor. Vatican Museum contains a number of wings. Lower Floor has these wings (Greek & Roman, Decorative Art, Art of XII -XVII , Art of XIX-XXI, Egyptian Art, Early Christian & Special Exhibition) most of the space under the type of indoor expect the landscape courtyards are outdoor spaces . Upper Floor has (Greek & Roman, Art of XII -XVII , Art of XIX-XXI & Etruscan Art) designed in the indoor area of the floor with view to the courtyards. The Basement Floor of the building has a full indoor space exhibited (Ethnic Art, Papal Carriages Collection & Special Exhibition) wings. Here average 18600 people per day on the total area 162000 m², the density results as 0.11 for per meter square. The inventory table: Introduction to Vatican Museum (Table 4.5).

Table 4.5: Inventory Table: Introduction to the Vatican Museum

VATICAN MUSEUM, ROME, ITALY			
INTERIOR VIEWS			
			
Architectural Drawing & Map		Building (Outdoor, Semi Outdoor, Indoor)	Parts \ Wings
Lower Floor Architectural Drawing	Lower Floor, Map		
			
Upper Floor Architectural Drawing	Upper Floor, Map		
			
Basement Floor Architectural Drawing	Basement Floor Map		
			
Crowds Denisty			
Average visitor per aday is : 18600	Totally Area : 162000 m2	0.11 per meter sqaure	Year of 2018

- **Aspects of the Study**

The architectural drawings along with maps have been analyzed throughout certain aspects: Layout organization, Accessibility & zoning, and Relation between (pathway-layout), for each floor of the Vatican museum and sorted in tables.

- **Layout Organization**

All of the floors in in Vatican Museum, have been designed with Linear Organization Type. Each floor linked & organized the functions of the space along its length. The floors have walls that separated the interior space into different zones & fields (Figures 4.17 & 4.18 & 4.19).

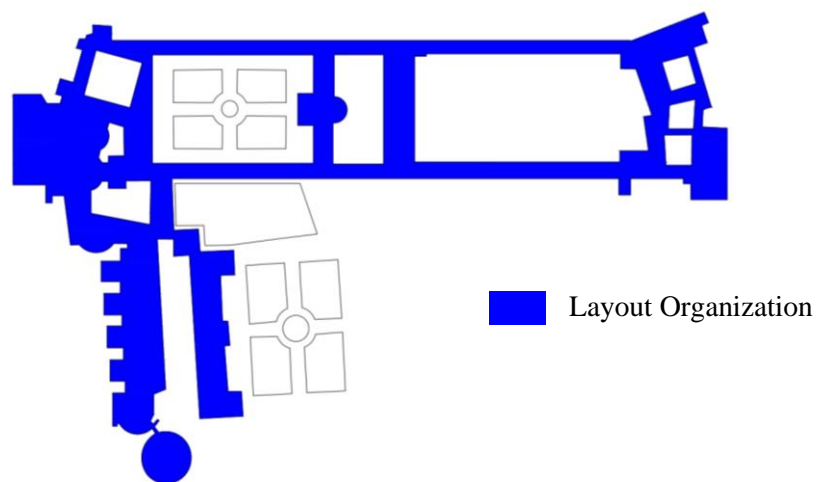

Figure 4.17: Lower Floor, Linear Organization, Vatican Museum

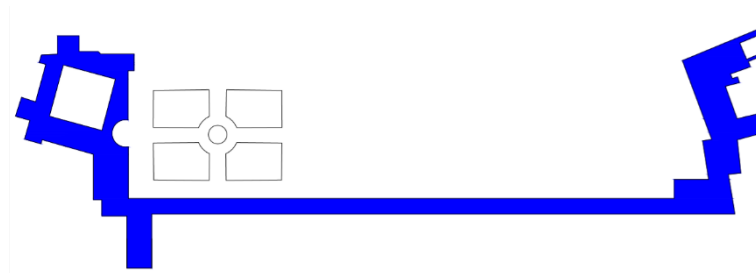

Figure 4.18: Upper Floor, Linear Organization, Vatican Museum

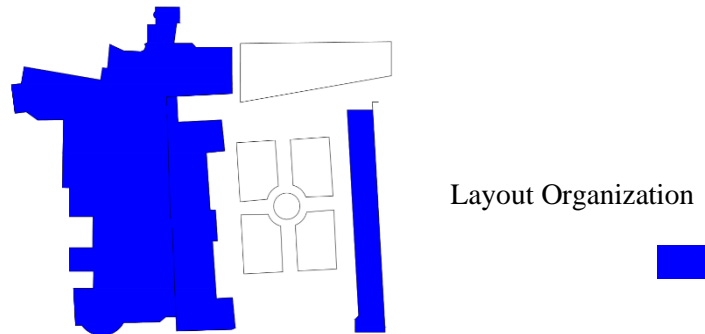

Figure 4.19: Basement Floor, Linear Organization, Vatican Museum

➤ **Accessibility (access points) and Zoning (exhibited space & foyer).**

The Lower Floor, has main foyer includes the Entrance & Exit, another one located in the opposite side of the building. The access points that located near Entrance & Exit side: Stairs (S), Lifts (L) & one Escalator (E) lead to Upper Floor & Basement Floor. Another foyer has access points lead only to Upper floor (Figure 4.20).

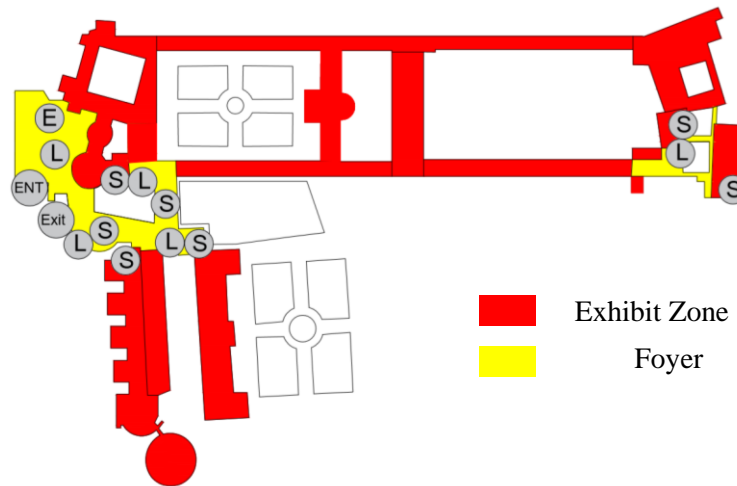

Figure 4.20: Lower Floor, Access points, Exhibitions area & Foyers, Vatican Museum

The Upper Floor, has also two foyers with access points that lead the visitor to reach the Lower Floor & Basement Floor, however, these points: Stairs & Lifts work as a starting points for the journey within the exhibited halls (Figure 4.21).

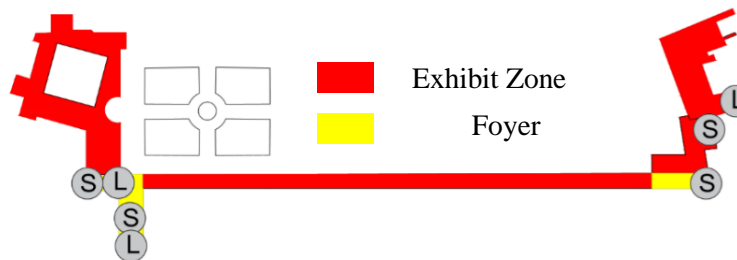

Figure 4.21: Upper Floor, Access points, Exhibitions area & Foyers, Vatican Museum

The Basement Floor, has one foyer with access points: Stairs & Lift, lead vertically to the Upper floor. These points defined as a starting point for the visitors (Figure 4.22).

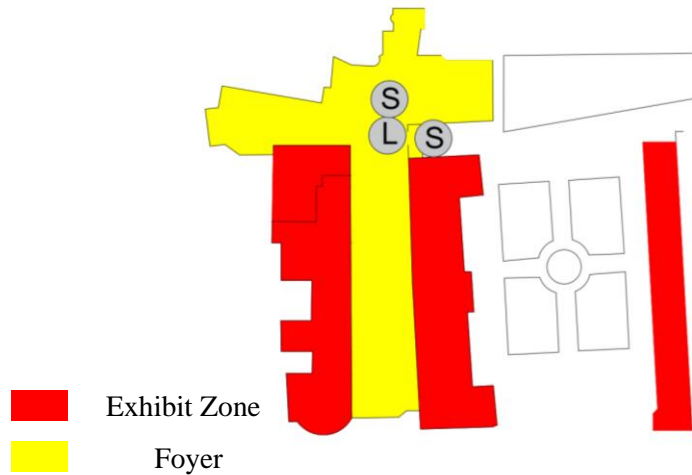

Figure 4.22: Basement Floor, Access points, Exhibitions area & Foyers, Vatican Museum

➤ **Pathway-Layout Relation**

The three floors have the same type of layout organization which reflect the same relation between (pathway-layout): Linear Procession (Figures 4.23, 4.24 & 4.25).

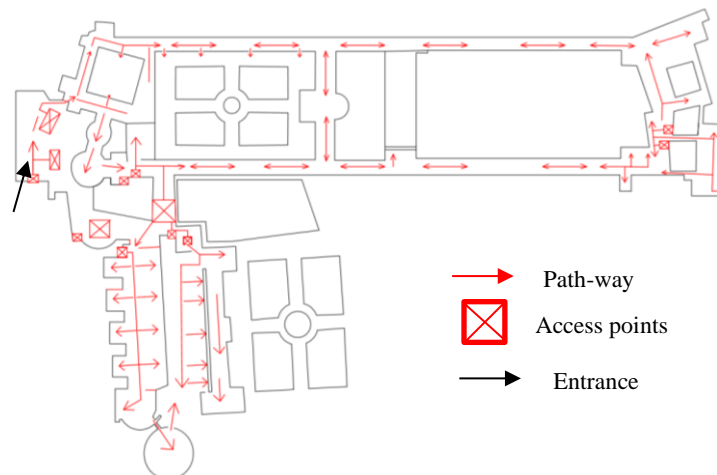

Figure 4.23: Lower Floor, linear procession, Vatican Museum

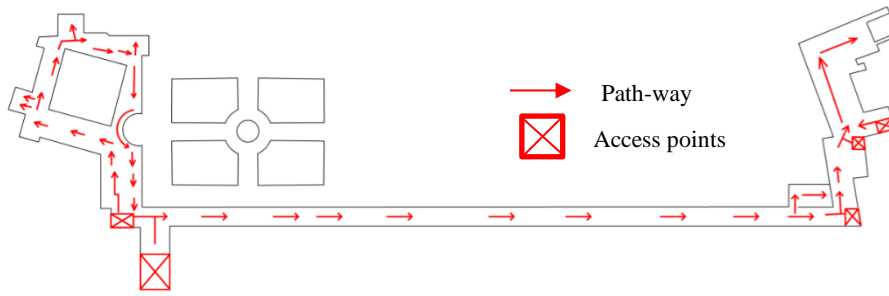

Figure 4.24: Upper Floor, linear procession, Vatican Museum

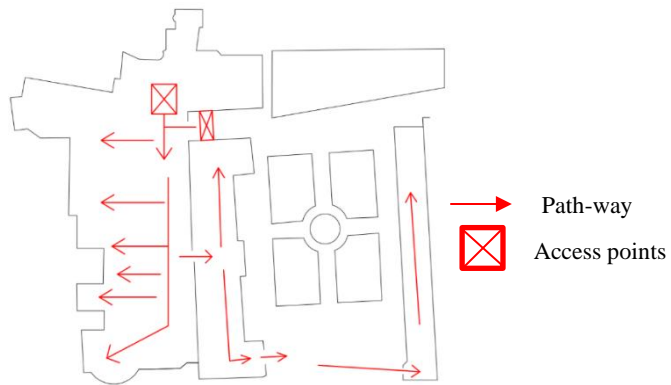
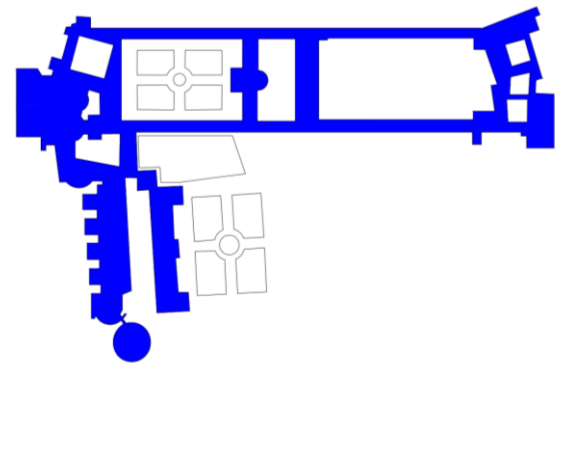
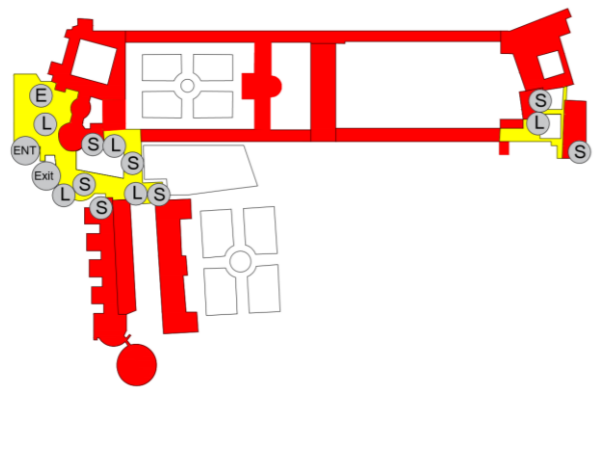
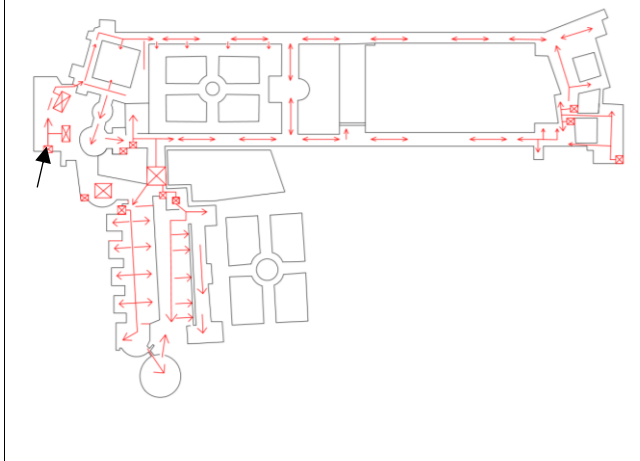
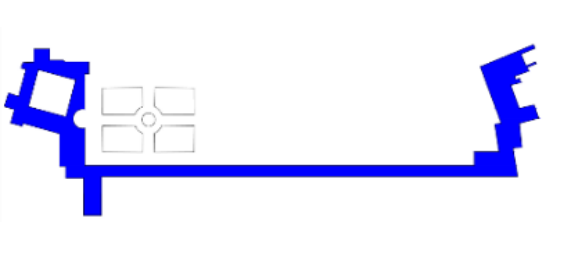
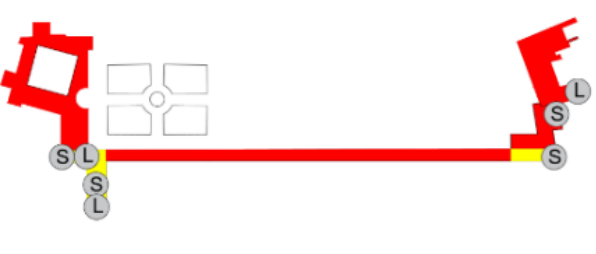
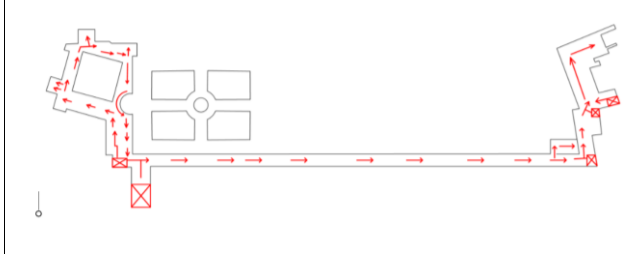
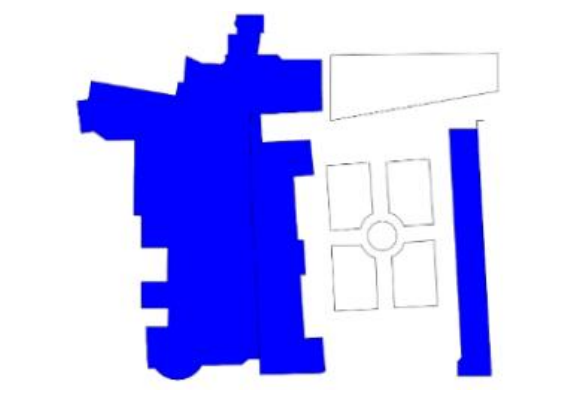
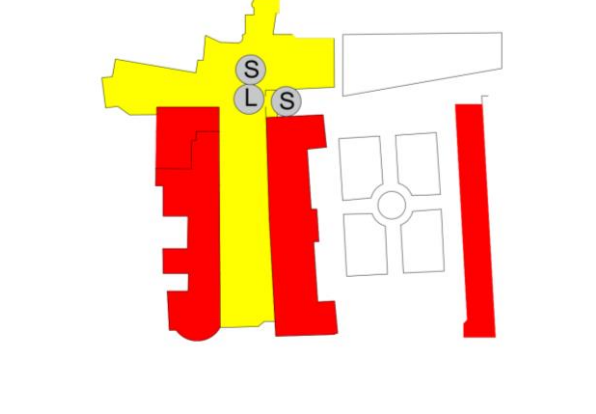
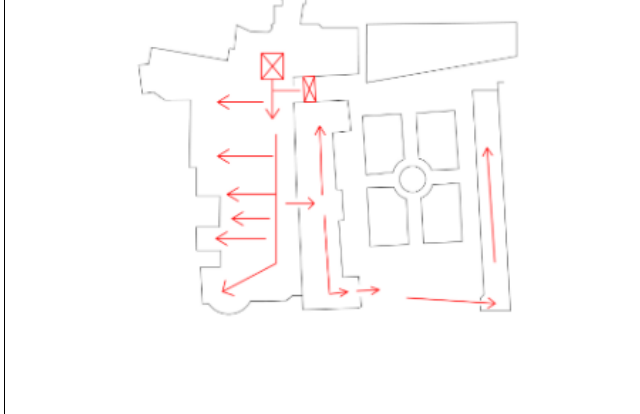

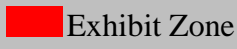







Figure 4.25: Basement Floor, linear procession, Vatican Museum

➤ **Summary of Vatican Museums Layout Analysis**

The three floors of the Vatican Museum have the same type of organization “Linear Organization Type”. The Entrance & the Exit of the building located in the Lower floor. The Lower floor has various access points lead the visitors to Upper & Basement floors. Secondary foyers distributed within the three floors. Moving vertically throughout the access points: Stairs, Lifts & Escalators which also worked as a starting points for the visitor’s journey. Finding that the three floors have a “Linear procession” type of relation between layout and pathway. The inventory table Layout Analysis of Vatican Museum Three Floors (Table 4.6).

Table 4.6: Layout Analysis of Vatican Museum Three Floors

LAYOUT ANALYSIS OF VATICAN MUSEUM THREE FLOORS		
Layout organization	Access points, Exhibitions' area & Foyers	Type of relation (pathway-layout)
		
Lower Floor Linear Organization Type		Lower Floor Linear Procession Type
		
Upper Floor Linear Organization Type		Upper Floor Linear Procession Type
		
Basement Floor Linear Organization Type		Basement Floor Linear Procession Type
 Layout Organization	 Exhibit Zone  Foyer  Stair  Lift	 Path-way  Access points  Entrance

4.3.3 British Museum, London, UK

- **Historical Background of the British Museum**

The British Museum is a public institution dedicated to human history, art, and culture, in London's Bloomsbury area, United Kingdom. The British Museum is the oldest national museum free for the public. It was founded in 1753 and opened in 1759. The collection on display was based on Irish physicist and naturalist Sir Hans Sloane (1660–1753), a physician and scientist based in London (The Editors of Encyclopedia Britannica, 2020) In order to preserve these collections, it is necessary to decide where the site is. The Montague House was the Museum building (Figure 4.6).



Figure 4.26: Montagu House (URL 6)

Soon, the need for space was so great that in 1823 Montagu House began to be demolished to make way for the much larger Greek Revival-style building of the architect Sir Robert Smirke that we know today (Blog, 2020). The construction of the building expanded and has additions during the years. In the construction of the building, the latest technology has been integrated, including the soaring dome of the Round Reading Room (opened in 1857) and the Queen Elizabeth II Great Court which encloses the one designed by Foster and Partners opened in 2000 (British museums, 2020). In 2018, the British Museum received 5.8 million visitors, is ranked sixth in the

list of most visited museums in the world, as per the theme index museum AECOM and TEA. It's historical context & the location in the European area make it the third case study for this thesis.

- **Architecture Drawing and Maps of British Museum**

The architectural drawings along with visitors' maps of British Museum present that there are 3 main floors of the buildings, Ground floor includes levels of (0, -1, 1,2), Upper floor includes levels (3,4,5) and Lower floor include levels of (-1, -2). British Museum contains large number of wings. Ground Floor has these wings (Middle East, Americans, Ancient Greek & Rome, Egypt & Asia) all of its zones under the type of indoor except the Great Court in the middle has semi-outdoor type. Upper Floor has (Middle East, Europe, Ancient Greek & Rome, Egypt & Asia) designed in the indoor area of the floor with limited spaces for semi-outdoor near the reading room in the center. The Lower Floor in the building has a full indoor exhibited the Africa wing with zones for Educational purpose. Here average 16164 people per day on the total area 92 000 m², the density results as 0.17 for per meter square. See the inventory table: Introduction to British Museum (Table 4.7).

Table 4.7: Inventory Table: Introduction to the British Museum

BRITISH MUSEUM, LONDON, UK			
INTERIOR VIEWS			
Architectural Drawing & Map		Building (Outdoor, Semi Outdoor, Indoor)	Parts \ Wings
Ground Floor: Levels (0, -1,1,2), Architectural Drawing	Ground floor: levels (0, -1,1,2), Map		
Upper Floor: Levels (3,4,5), Architectural Drawing	Upper Floor: Levels (3,4,5), Map		
Lower Floor: Levels (-1, -2), Architectural Drawing	Lower Floor: Levels (-1, -2), Map		
Crowd Density			
Average visitor per aday is : 16164	Totally Area : 92000 m2	0.17 per meter sqaure	Year of 2018

- **Aspects of the Study**

The architectural drawings along with maps have been analyzed throughout certain aspects: Layout organization, Accessibility & zoning, and Relation between (pathway-layout), for each floor of the British museum and sorted in tables

- **Layout Organization**

The Ground floor in level 0, the exhibited halls arranged around a centre court, and each of the halls in every level (0, -1, -2) has a linear organization type, together the layout shows a Radial Organization type (Figure 4.27).

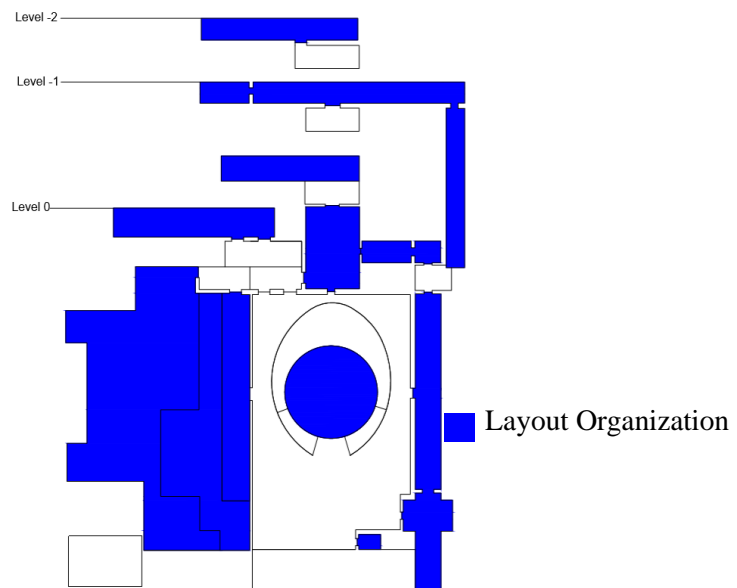

Figure 4.27: Ground Floor, Radial Organization, British Museum

The Upper Floor has been arranged in Centralized Organization layout type. All of the secondary spaces are connected to each other by one central area in the middle of the floor (Figure 4.28).

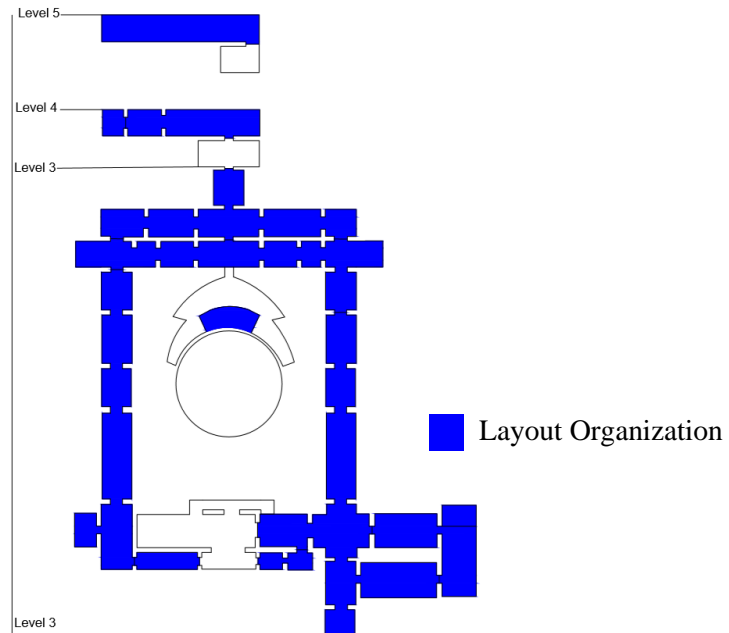

Figure 4.28: Upper Floor, Centralized Organization, British Museum

The Lower Floor, has two main zones. Every zone has a function arranged in an offset of a middle pathway. The layout shows a Linear Organization (Figure 4.29).

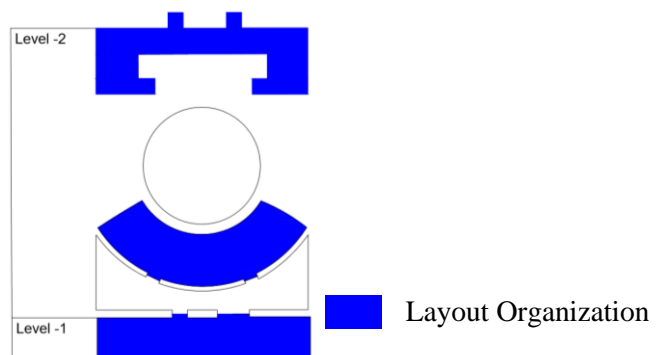

Figure 4.29: Lower Floor, Linear Organization, British Museum

➤ **Accessibility (access points) and Zoning (exhibited space & foyer).**

The Ground Floor, has the main Entrance of the whole building. The floor includes a large court defined as a central foyer and main gathering space. The Court leads to the Upper & Lower floor throughout various access points, Furthermore, Ground Floor has a secondary foyer that include the vertical access points: stairs (S) & lifts (L) leading the visitors to the levels (0, -1, -2) (Figure 4.30).

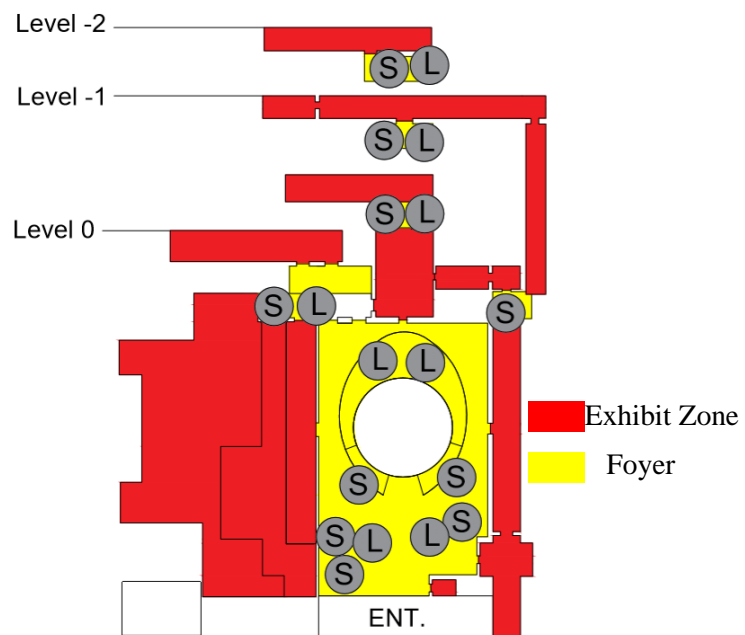

Figure 4.30: Ground Floor, Access points, Exhibitions area & Foyers, British Museum

The Upper Floor, started with a foyer full of vertical access points: stairs (S) & lifts (L), also the exhibitions halls have a number of these points. Each one of the levels (3, 4, 5) has a small foyer (Figure 4.31).

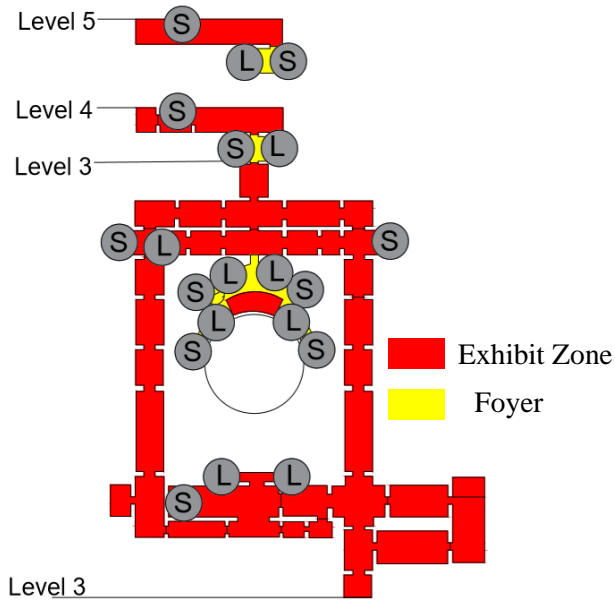

Figure 4.31: Upper Floor, Access points, Exhibitions area & Foyers, British Museum

The Lower Floor includes two levels (-1, -2) has a foyer in level -1 that connected by Stairs & Lifts with Ground Floor & Upper Floor. Also, Level -1 has two Lifts lead to level -2 in the same Lower Floor. The lowest level here (-2) has two Stairs connected with Level 0 in Ground Floor (Figure 4.32).

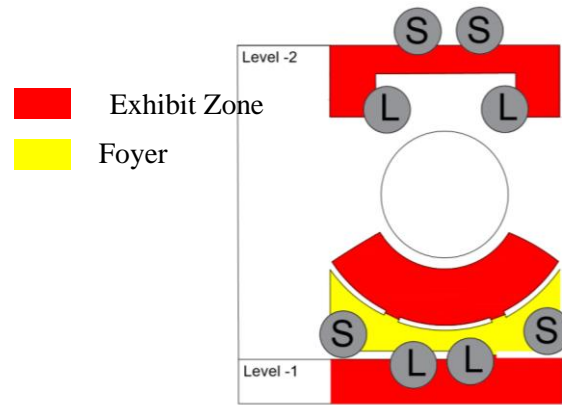

Figure 4.32: Lower Floor, Access points, Exhibitions area & Foyers, British Museum

➤ **Pathway-Layout Relation**

The Ground Floor in the British Museum has the main Entrance lead to a Great Court in the middle of the floor. In the center of the Court this is a reading room designed in circle form. Configuration of the pathway shows a Core relation between the layout & pathway (Figure 4.33).

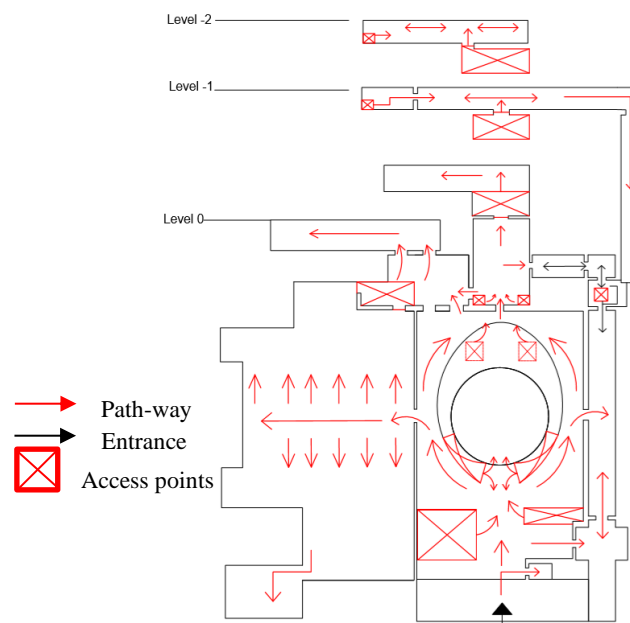

Figure 4.33: Ground Floor, Core, British Museum

The Upper Floor, has a centralization layout design, which shows generally a Loop pattern for pathways. The visitors should come back to the center to reach any other floor (Figure 4.34).

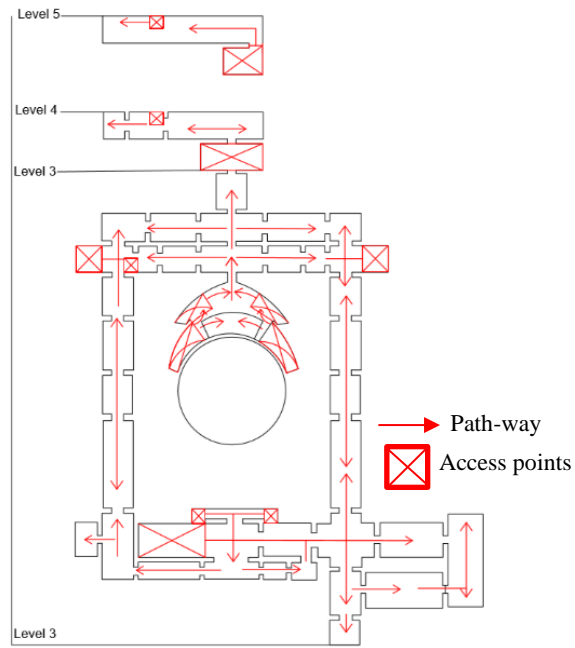

Figure 4.34: Upper Floor, Loop, British Museum

The Lower Floor, has a linear procession for both -1 & -2 levels. (Figure 4.35)

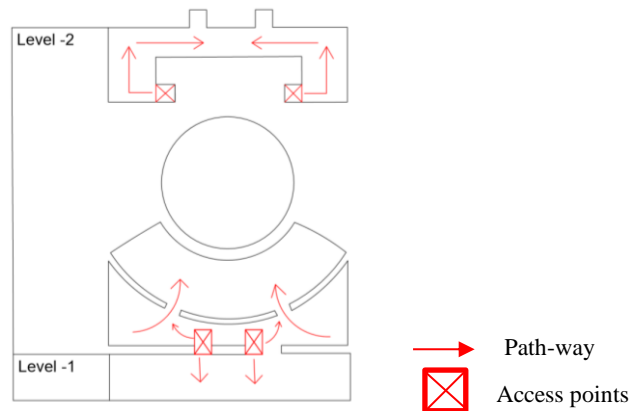
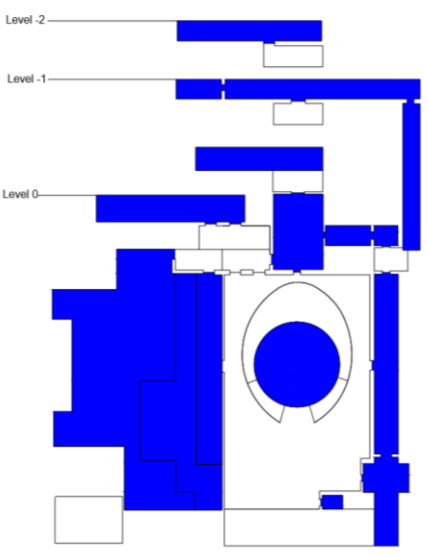
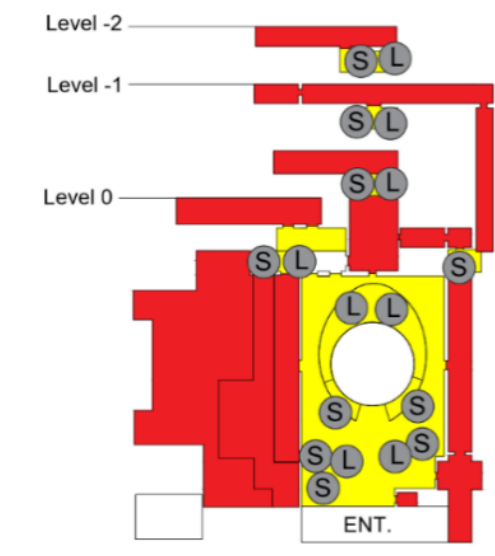
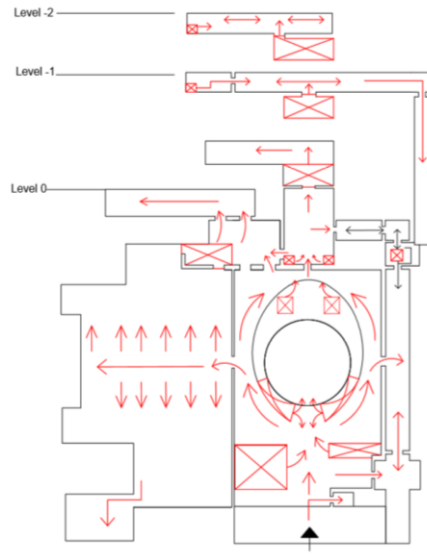
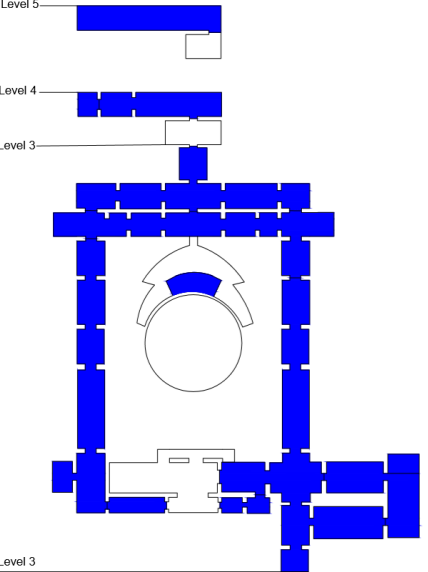
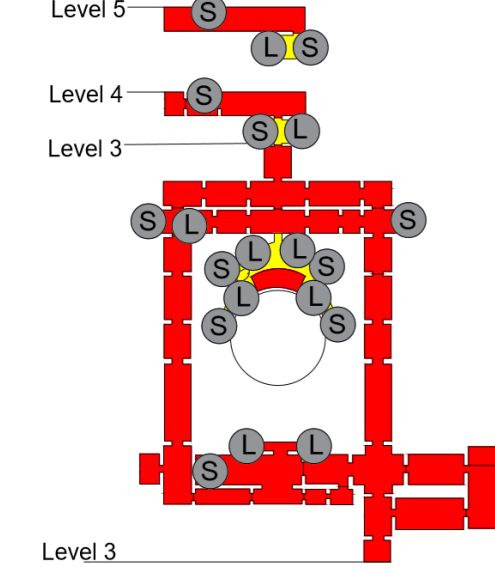
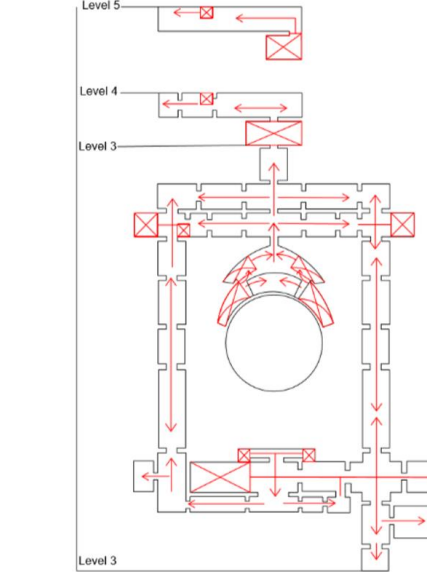
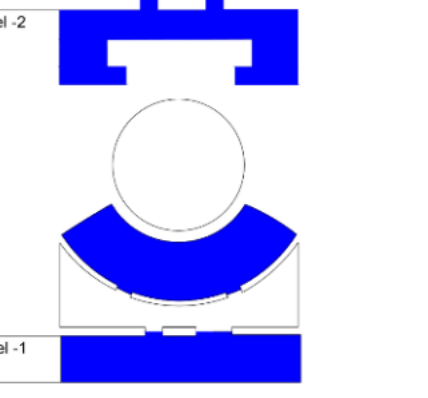
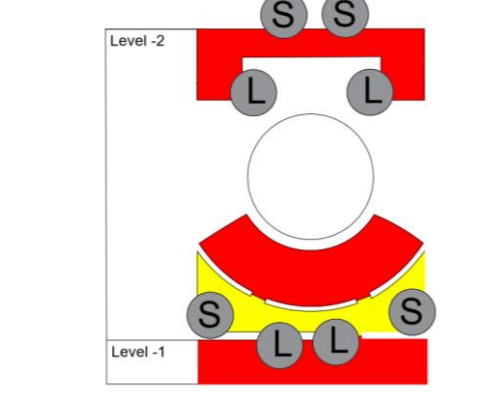
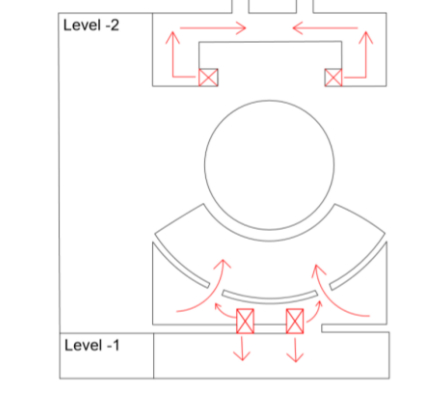

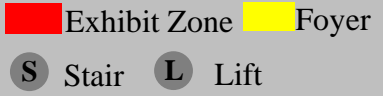
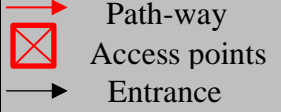

Figure 4.35: Lower Floor, linear procession, British Museum

➤ **Summary of British Museums Layout Analysis**

The spatial organization of British Museum differ between the three floors (Ground, Upper & Lower). The type of organization is Radial, Centralization, and Linear respectively. Entrance of the Building located in the Ground floor near the main street. The building has main large foyer named “Great Court” located in the Ground Floor. Secondary foyers distributed within the three floors. Moving vertically throughout the access points: Stairs, Lifts & Escalators which also worked as a staring points for the visitor’s journey. Finding that the relation between layout and pathway is Core, Loop, and Linear Procession. The inventory table Layout Analysis of British Museum Three Floors (Table 4.8).

Table 4.8: Layout Analysis of British Museum Three Floors

LAYOUT ANALYSIS OF BRITISH MUSEUM THREE FLOORS		
Layout organization	Access points, Exhibitions' area & Foyers	Type of relation (pathway-layout)
		
Ground Floor levels (0, -1, 1, 2), Radial Organization Type		Ground Floor levels (0, -1, 1, 2), Core Type
		
Upper Floor levels (3, 4, 5) Centralized Organization Type		Upper Floor levels (3, 4, 5) Loop Type
		
Lower Floor levels (-1, -2) Linear Organization Type		Lower Floor levels (-1, -2) Linear Procession Type
 Layout Organization		

4.3.4 National Gallery, London, UK

- **Historical Background of the National Gallery**

The National Gallery was founded in 1824 after the British government purchased from the financier and collector John Julius a collection of 38 pictures, composed of Italian, Dutch, and English paintings. The construction of the gallery, designed by William Wilkins, was completed and opened at Trafalgar Square in 1838, as this was known London's center. Asper the national government decided to make sure all classes of society could appreciate the artwork; the place could be easily accessed on foot (Gill, 2016). The National Gallery stands on the King's Mews (Figure 4.36) former site. William Wilkins, the architect of the Museum, used many of the Mews building's design techniques when he designed the National Gallery. Nearby Carlton House (Figure 4.37), the Prince Regent's former home was demolished in 1826 but its impressive columns were preserved. Eight of the columns Wilkins selected for use in his new National Gallery building (National Gallery, 2020). The building has been expanded throughout the years. Another wing has been added called " Sainsbury". Upon the restoration, the gallery was able to return to an immense array of paintings made by British artists, which due to lack of space had to be shown elsewhere. Lord Sainsbury and his brothers, Simon and Timothy Sainsbury, agreed in 1985 to finance the construction of a new wing to ensure space for permanent collections and changing exhibitions (Gill, 2016).

In 2018, National Gallery received 5.7 million visitors, is ranked eighth in the list of most visited museums in the world, as per the theme index museum AECOM and TEA. It's historical context & the location in the European area make it the fourth case study for this thesis.



Figure 4.36: Interior of Kings Mews (URL 7)

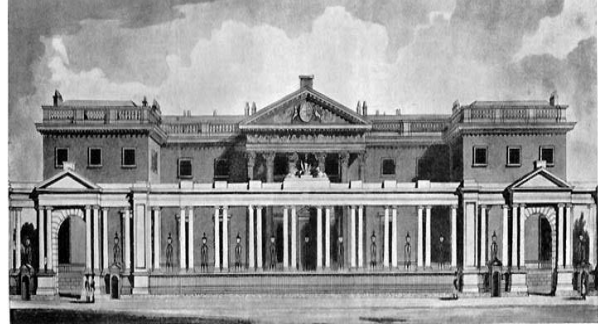



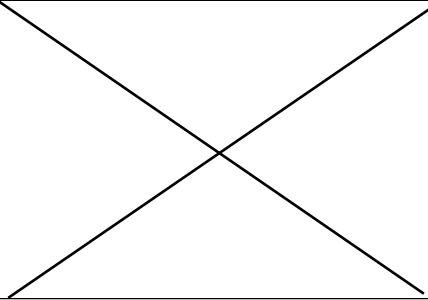

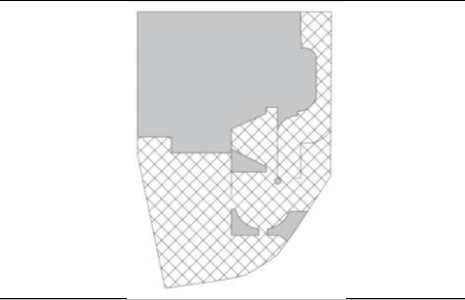
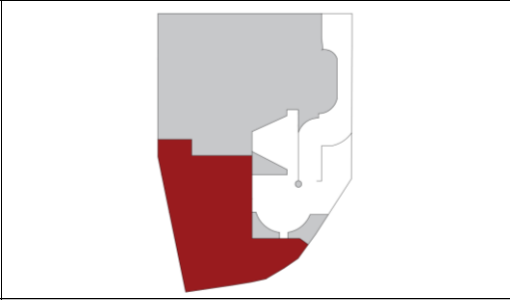
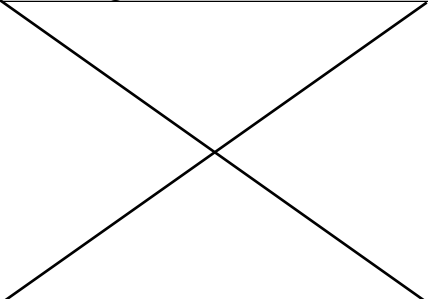

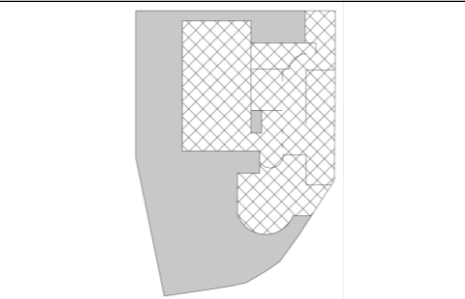
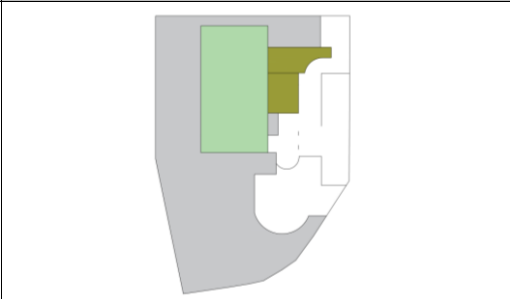
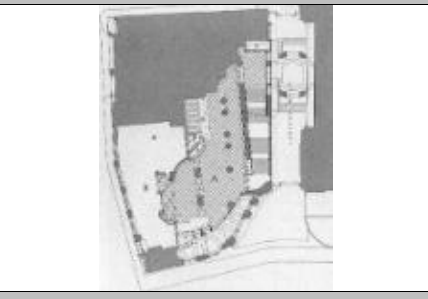

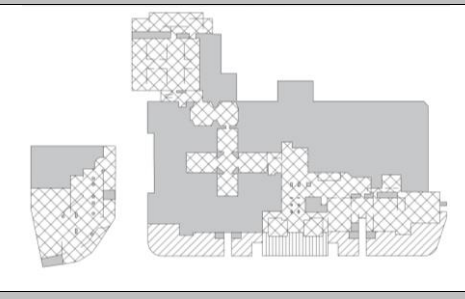
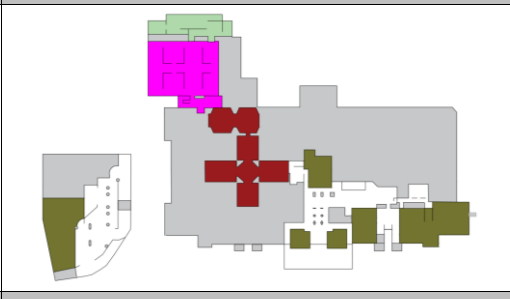

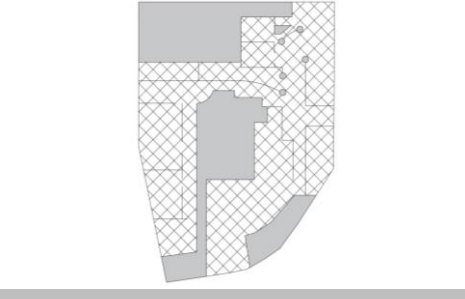
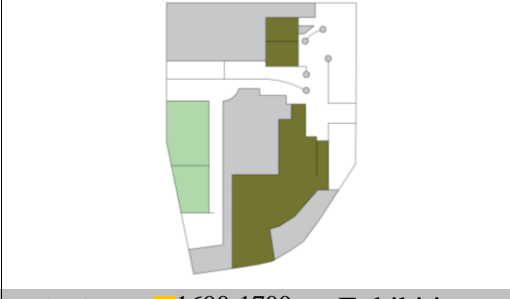
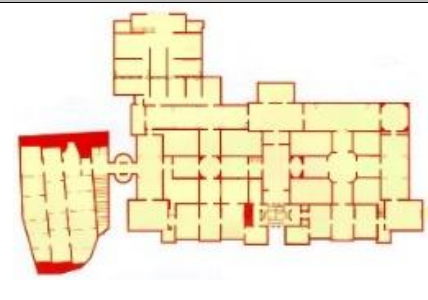

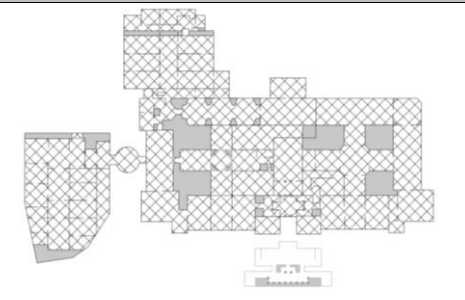



Figure 4.37: The Frontage of Carlton House (URL 8)

- **Architecture Drawing and Maps of National Gallery**

The architectural drawings along with visitors' maps of National Gallery present that there are two parts connected together create the whole Gallery. Firstly, the zones of the main part have occupied Floor 2 & Ground Floor (0), However, Sainsbury part present 5 levels: Floor -1, -2, 0, 1, 2. Floor 2 has been named as the main floor, here the visitor can access the two parts. The National Gallery include wings sorted as: Galleries, Exhibitions, Paintings, Educational zones & services. The displayed paintings are distributed according to the period of date and have been all introduced in Floor 2 as: (1200-1500, 1500-1600, 1600-1700 & 1700-1930). The Ground Floor has the Galleries & Exhibitions wings plus the services. All of its zones under the type of indoor area except the Entrance has semi-outdoor area. The Sainsbury Wing is located in Floor -2 as indoor area. Floors -1, 1 have indoor spaces with functions of Educational & Services. Here average 15 616 people per day on the total area 46 369 m², the density results as 0.33 for per meter square. The inventory table Introduction to National Gallery (Table 4.9).

Table 4.9: Inventory Table: Introduction to the National Gallery

NATIONALL GALLERY, LONDON, UK			
INTERIOR VIEWS			
			
Architectural Drawing & Map		Building (Outdoor, Semi Outdoor, Indoor)	Parts \ Wings
Floor -2, Architectural Drawing	Floor -2, Map	☒ In door	■ Sainsbury Exhibition
			
Floor -1, Architectural Drawing	Floor -1, Map	☒ In door	■ Educational ■ Service
			
Floor 0, Architectural Drawing	Floor 0, Map	☒ In door ☒ Outdoor ☒ Semi-Outdoor	■ Galleries ■ Exhibitions ■ Service ■ Educational
			
Floor 1, Architectural Drawing	Floor 1, Map	☒ In door	■ Educational ■ Service
			
Floor 2, Architectural Drawing	Floor 2, Map	☒ In door	Paintings: <ul style="list-style-type: none"> ■ 1600-1700 ■ 1200-1500 ■ 1500-1600 ■ 1700-1930 ■ Exhibitions ■ Service ■ Educational
			
Crowd Density			
Average visitor per aday is : 15 616	Totally Area : 46 369 m2	0.33 per meter sqaure	Year of 2018

- **Aspects of the Study**

The architectural drawings along with maps have been analyzed throughout certain aspects: Layout organization, Accessibility & zoning, and Relation between (pathway-layout). Floors: (-2, 0, 2) of the National Gallery have been analyzed because these are the floors that contain exhibition halls and sorted in tables.

- **Layout Organization**

In Floor -2 there are two zones, one foyer & one exhibition hall. Located side by side in a linear Organization (Figure 4.38).

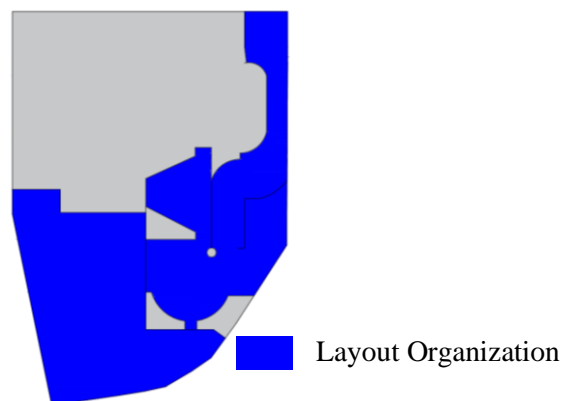

Figure 4.38: Floor -2, Linear Organization, National Gallery

Ground Floor (0) has in the middle one foyer and court that other zones distributed around it with a linear access line, together the layout sorted under the type of Radial Organization (Figure 4.39).

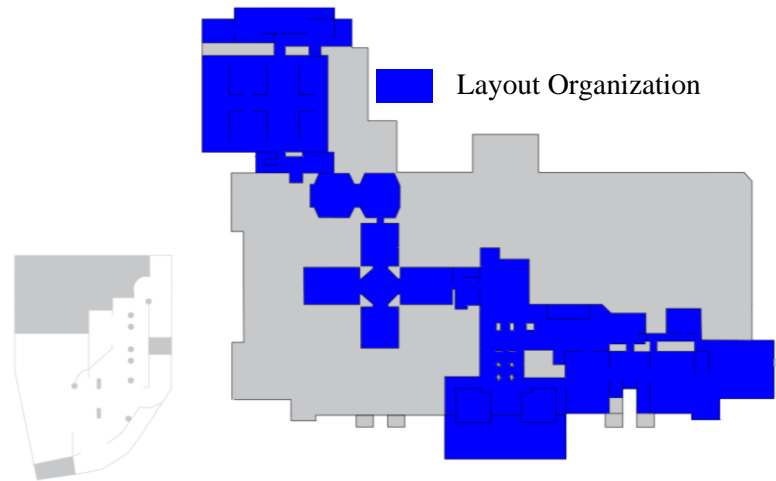

Figure 4.39: Ground Floor (0), Radial Organization, National Gallery

Floor 2, the main floor in National Gallery Building, has all the exhibition halls organizational around the central foyer. The layout is a Radial Organization type (Figure 4.40).

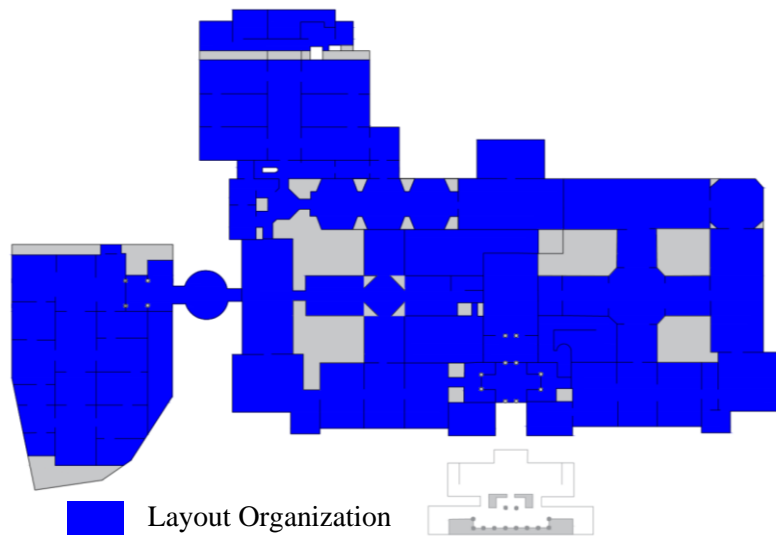

Figure 4.40: Floor 2, Radial Organization, National Gallery

➤ **Accessibility (access points) and Zoning (exhibited space & foyer)**

Floor-2, there are two vertical access point within a foyer, Stair (S) & Lift (L) (Figure 4.41).

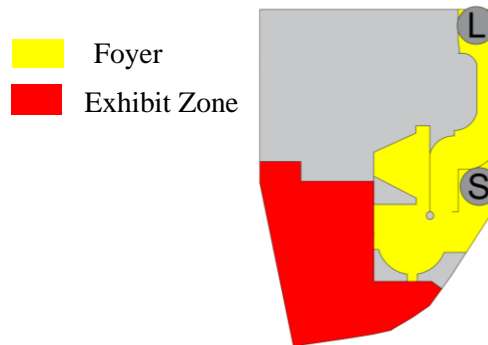

Figure 4.41: Floor-2, Access points, Exhibitions area & Foyers, National Gallery

The National Gallery can be entered through Four Entrances located in the Ground Floor (0). The main part has three of the Entrances and one for Sainsbury part. Stairs (S) & Lifts (L) are available within the two foyers & exhibition area, which are working as a starting point for the visitors (Figure 4.42).

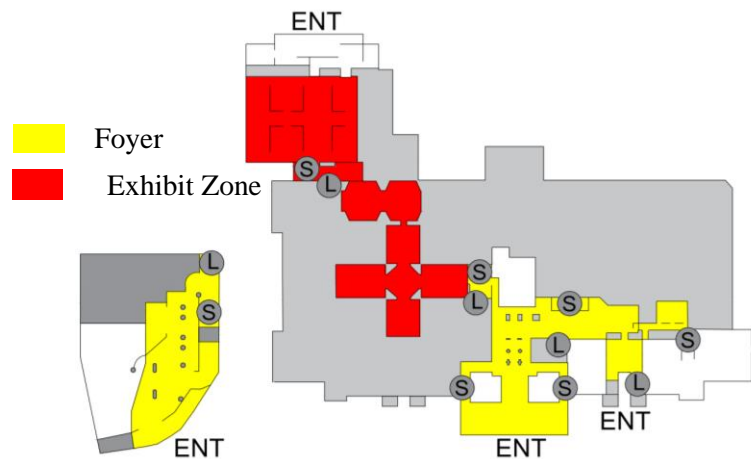

Figure 4.42: Ground Floor, Access points, Exhibitions area & Foyers, National Gallery

The visitors can reach Floor 2 through the vertical access point: Stairs (S) & Lifts (L) that connected both Ground Floor & Floor 2 (Figure 4.43).

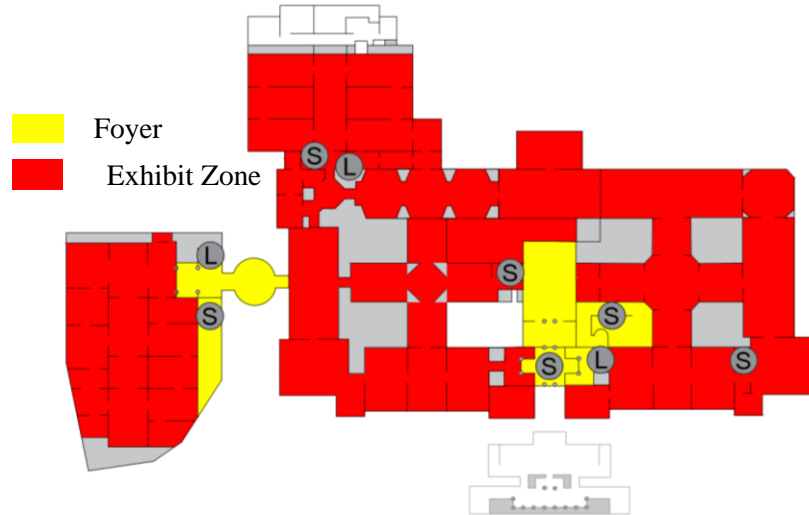

Figure 4.43: Floor 2, Access points, Exhibitions area & Lobbies, National Gallery

➤ **Pathway-Layout Relation**

Floor -2 has reflected the Linear Procession type of relation (Figure 4.44).

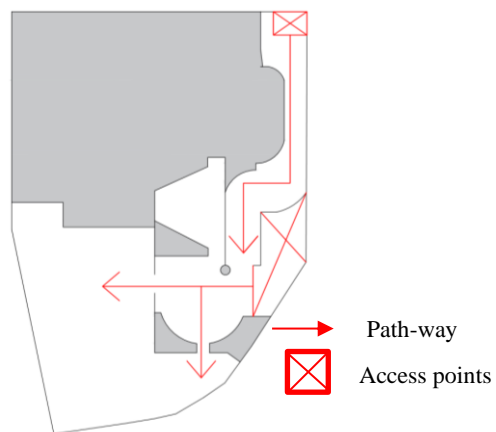

Figure 4.44: Floor-2, Linear Procession, National Gallery

Ground Floor (0) has mixed Linear and Core relation, together created a Complex type of relation in both building parts (Figure 4.45).

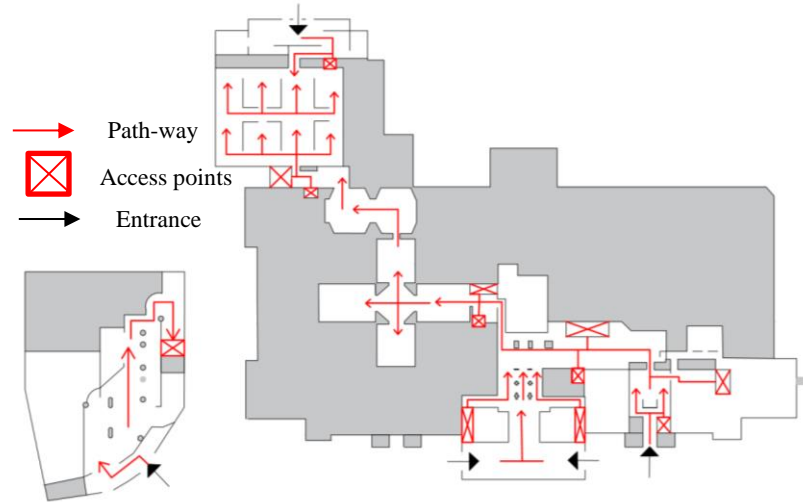

Figure 4.45: Ground Floor (0), Complex, National Gallery

Floor 2 has a main foyer in the center with various Linear pathways that leads to all halls within the whole building. Core relation type (Figure 4.46).

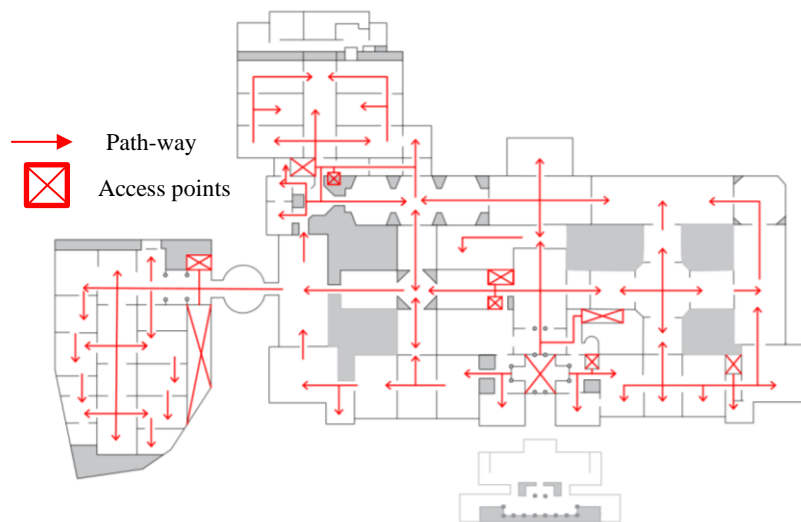
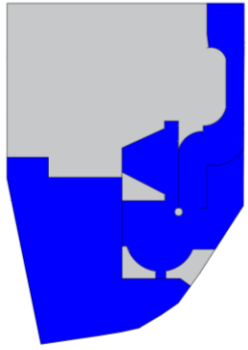
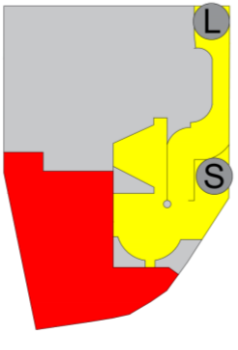
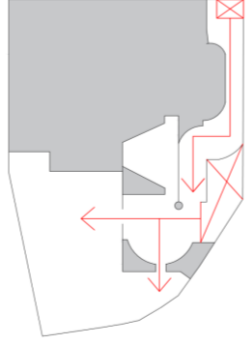
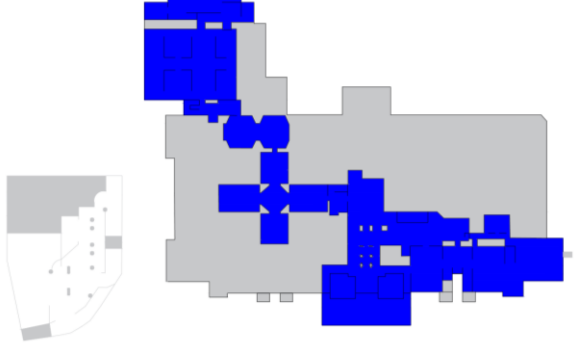
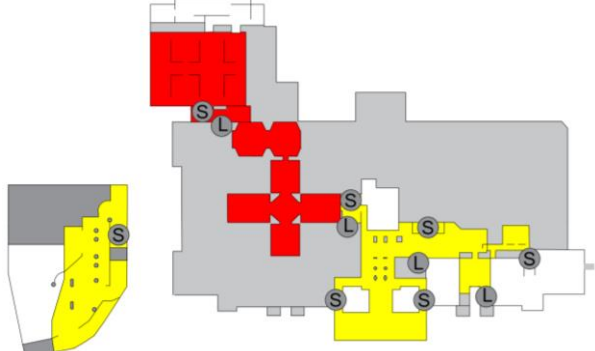
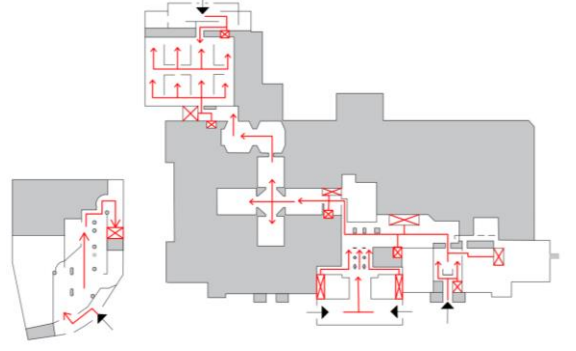
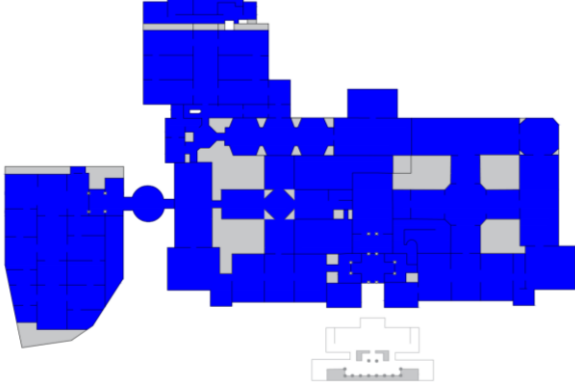

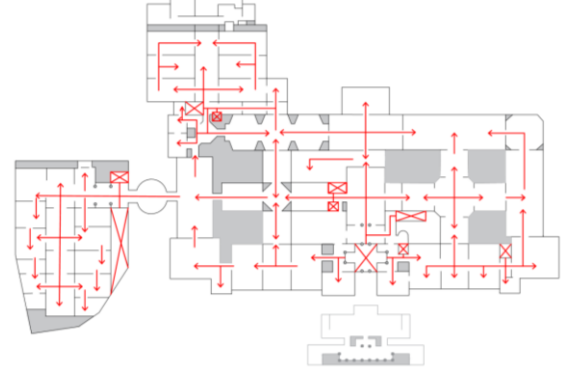



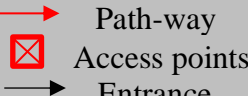

Figure 4.46: Floor 2, Core, National Gallery

➤ **Summary of National Gallery Layout Analysis**

The spatial organization of National Gallery differ between the three floors (-2, 0, 2) that include the exhibitions areas. The type of organization is Radial for the Ground & Floor 2; However, it is a linear type for Floor -2. Entrances of the Building are located in the Ground floor with three various options within the main part and one on the Sainsbury part of the National gallery. The building has foyers located in the three floors. Moving vertically throughout the access points: Stairs & Lifts which are also worked as a starting points for the visitor's journey. Finding the relations between layout and pathway are Linear Procession, Complex & Core respectively. The inventory table Layout Analysis of National Gallery Three of The Floors (Table 4.10).

Table 4.10: Layout Analysis of National Gallery Three of the Floors

LAYOUT ANALYSIS OF NATIONAL GALLERY THREE OF THE FLOORS		
Layout organization	Access points, Exhibitions' area & Foyers	Type of relation (pathway-layout)
		
Floor -2 Linear Organization Type		Floor -2 Linear Procession
		
Ground Floor Radial Organization Type		Ground Floor Complex Type
		
Floor 2 Radial Organization Type		Floor 2 Core Type
 Layout Organization	 	

4.3.5 Natural History Museum, London, UK

- **Historical Background of Natural History Museum**

The story of the Natural History Museum which is located in South Kensington, London, United Kingdom started in the year 1753. In this year Sir Hans Sloane, which known as the "Physician, and Natural curiosity Collector" Agreed to give the country its extensive collection. For preserving this collection, a competition has been held to design a new Museum of Natural History. The location was occupied by the International Exhibition building of 1862. To establish the new museum parts of the International Exhibition were sold as materials and some zones remained used in the South Kensington Museums until 1949. However, the rest was slowly destroyed later. (Figure 4.47) (B.O.H). The winner of the competition was the architect Alfred Waterhouse. Waterhouse modified the design as German Romanesque, creating the magnificent building which currently knows. In 1883 the Collections of mineralogy and natural history stood in their new home. But in the end, the collections were not declared a museum their own right until 1963 (URL 9). In 2018, the Natural History Museum received 5.2 million visitors, is ranked ninth in the list of most visited museums in the world, as per the theme index museum AECOM and TEA. It's historical context & the location in the European area make it the fifth case study for this thesis.



Figure 4.47: International Exhibition building of 1862, London (URL 10)

- **Architecture Drawing and Map of Natural History Museum**

The available information about the Natural History Museum in London present the architectural drawings for the Ground Floor only for the year of 1883 (Figure 4.48), However, the Map from the official website shows; Lower Floor, Ground Floor, Mezzanine, Floor 1 & Floor 2 (Figure 4.49). This case study will be analyzed depending on the available data. The whole building sorted within the indoor area type. There are some zones that has a skylight example of the Central Hall can be sorted as semi-indoor area (Figure 4.50). The main wings have classified in 4 zones (Orange, Blue, Green and Red) plus the regular services and the Educational Zones like: Flett Events Theatre.

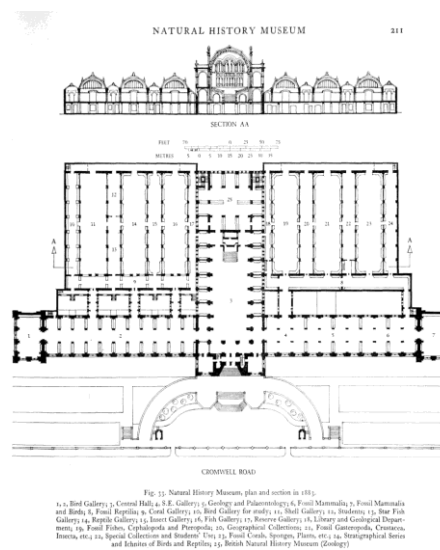

Figure 4.48: Architectural Drawing for Natural History Museum, 1883 (URL 12)

- **Aspects of the Study**

The architectural drawing along with map have been analyzed throughout certain aspects: Layout organization, Accessibility & zoning, and Relation between (pathway- layout), for the Ground Floor of the Natural History Museum.

- The Ground Floor shows both linear and center organization together sorted as a **Radial Type of Organization**.
- Accessibility to the whole building through 3 Entrances: Front Side leading direct to the Ground Floor (Cromwell Entrance), Right Side has (Exhibition Road Entrance) leads to Lower Floor and the Left Side has the Entrance lead also to the Lower floor (Queen’s Gate). The map provides information about the access points as; Stairs and Lifts.
- Relation between (Pathway-Layout) sorted as a **Core type**.

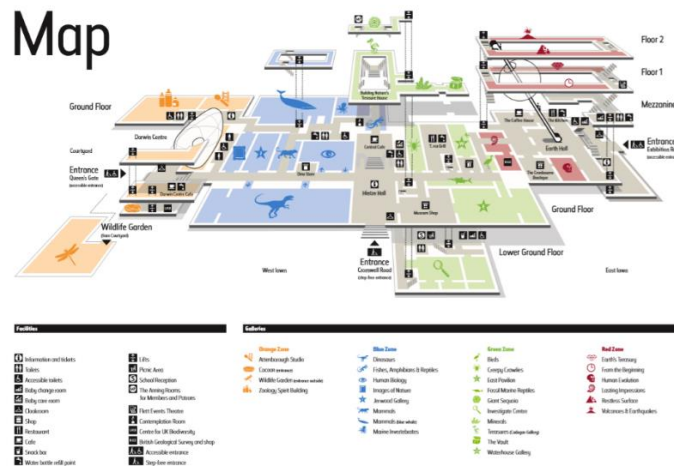

Figure 4.49: Map for Natural History Museum (URL 13)



Figure 4.50: Central Hall, Natural History Museum (URL 11)

4.3.6 Victoria & Albert Museum, London, UK

- **Historical Background of the Victoria & Albert Museum**

The Victoria and Albert Museum was first known as the Museum of Manufactures in the Great Exhibition of 1851. Several changes have been done until it's transferred to the current site. The V & A Museum which was known before as the " South Kensington Museum " is located in Brompton area was housed in Brompton Park House which had temporary-looking with iron galleries and was later reestablished to be the V&A Childhood Museum (Figure 4.51) (John, 1982). The museum was the first organization that has a mission to educate designers, manufacturers, and the public in art and design in 1852. Prince Albert, who saw the need to develop British industry standards and compete in the world marketplace he decided to use the Exhibition 's income to establish a cultural district of museums and colleges dedicated to art and science education in South Kensington where the V & B Museum housed now (V& A Museum, 2019). In 2018, the Victoria & Albert Museum received 3.9 million visitors, is ranked sixteenth in the list of most visited museums in the world, as per the theme index museum AECOM and TEA. It's historical context & the location in the European area make it the sixth case study for this thesis.

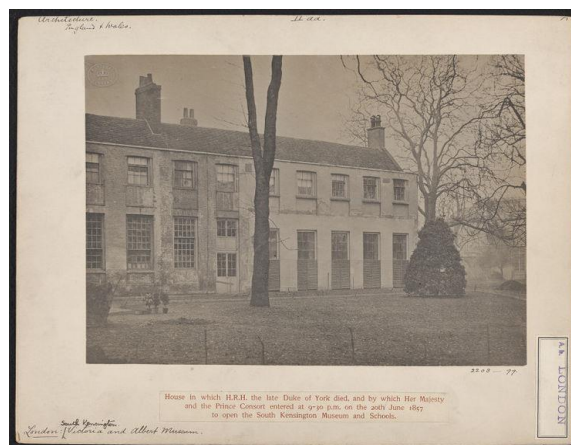

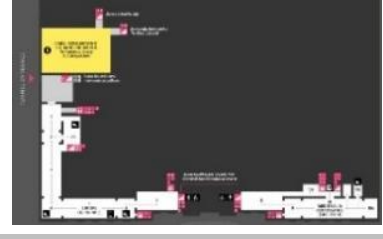
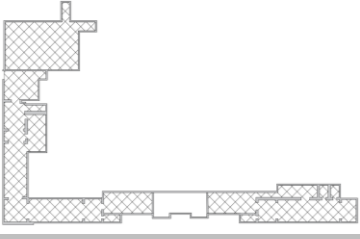
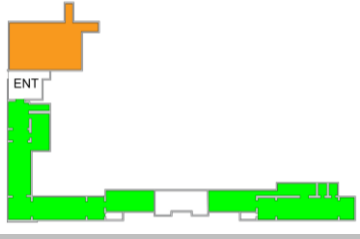
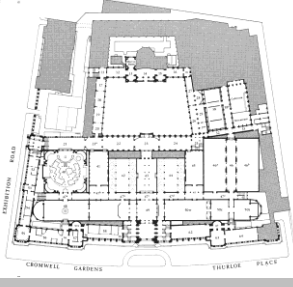

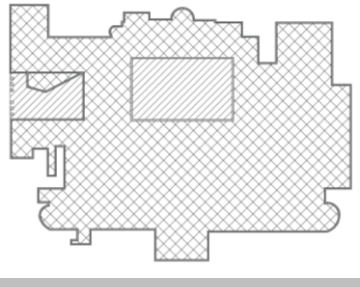
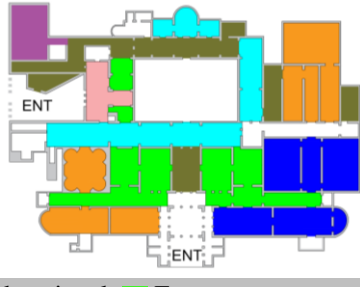

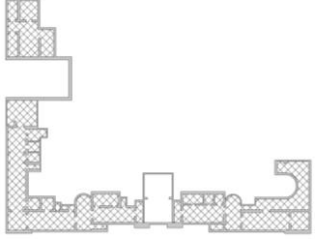
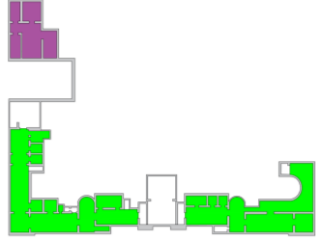
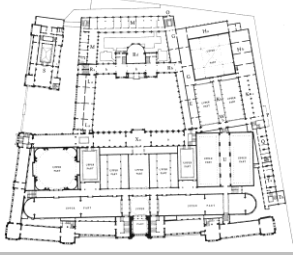

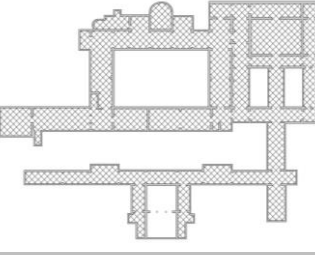
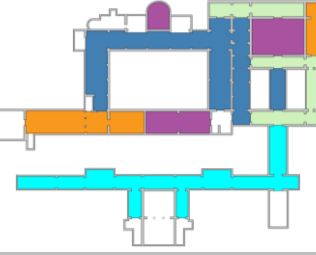
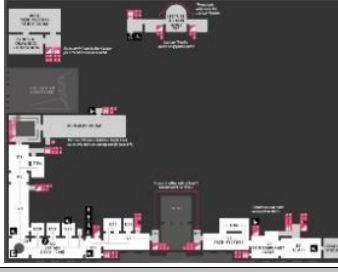
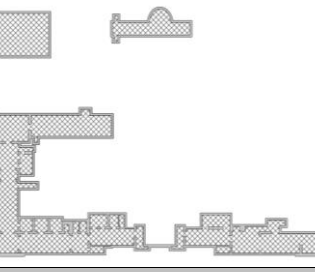
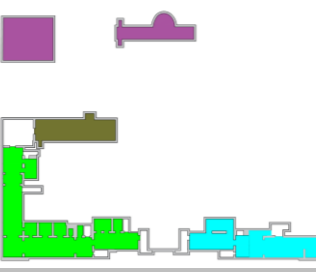
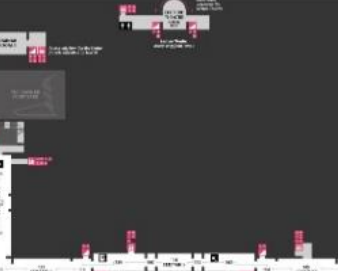



Figure 4.51: Exterior view of Brompton Park House (URL 14)

- **Architecture Drawing and Maps of Victoria & Albert Museum**

The architectural drawings along with visitors' maps of Victoria & Albert Museum explain that there are six floors in building. Ground Floor (0) has a Lower Floor -1, and Upper Floors are (1, 2, 3 ,4). Starting with Floor -1, that include parts of European wing & Temporary Exhibition. Ground Floor present various wings under the sort of Asia, Europe, Sculptures, (The Blavatnik Hall) a special exhibition & Temporary Exhibition. This Floor also has an Educational zone. Floor 1, also has two main parts: European wing & Educational Zone. Floor 2, contain the Furniture, Painting & Photography wings, Furthermore, Sculptures, various Material & Jewelry wings, Educational zone & Temporary Exhibition hall. Floor 3, has parts of the European wing, Architecture, Materials & an Educational zone. The Upper Floor 4, has Furniture & Ceramic displayed items and also an Educational zone. All of the six floors extended in indoor areas, expect the Ground Floor has in the middle "The Jahn Madejski Garden" and "The Sackler Courtyard" near the exhibition road entrance as outdoor spaces. Here average 10 684 people per day on the total area 50585 m², the density results as 0.11 for per meter square. See the inventory table: Introduction to Victoria & Albert Museum (Table 4.11).

Table 4.11: Inventory Table: Introduction to the Vitoria & Albert Museum

VICTORIA & ALBERT MUSEUM, LONDON, UK			
INTERIOR VIEWS			
			
Architectural Drawing & Map		Building (Outdoor, Indoor)	Parts \ Wings
Floor -1, Architecture Drawing	Floor -1, Map	☒ In door	■ Europe ■ Temporary Exhibition
X			
Floor 0, Architecture Drawing	Floor 0, Map	☒ Indoor ☒ Outdoor	■ Europe ■ Temporary Exh. ■ Asia ■ Special Exh. ■ Educational ■ Sculptures & Material ■ Service
			
Floor 1, Architecture Drawing	Floor 1, Map	☒ In door	■ Educational ■ Europe
X			
Floor 2, Architecture Drawing	Floor 2, Map	☒ In door	■ Furniture, Painting & Photography ■ Temporary Exh. ■ Educational ■ Jewelry ■ Sculptures & Material
			
Floor 3, Architecture Drawing	Floor 3, Map	☒ In door	■ Europe ■ Educational ■ Service ■ Sculptures & Material
X			
Floor 4, Architecture Drawing	Floor 4, Map	☒ In door	■ Furniture & Ceramic ■ Educational
X			
Crowds Density			
Average visitor per aday is : 10 684	Totally Area : 50585 m2	0.11 per meter sqaure	Year of 2018

- **Aspects of the Study**

The architectural drawings along with maps have been analyzed throughout certain aspects: Layout organization, Accessibility & zoning, and Relation between (pathway-layout), for each floor of the Victoria & Albert Museum and sorted in tables.

- **Layout Organization**

The exhibition areas in the layout of Floor -1 are distributed in two straight lines appear together as a 90-degree angle. The organization type here is Linear Type (Figure 4.52).

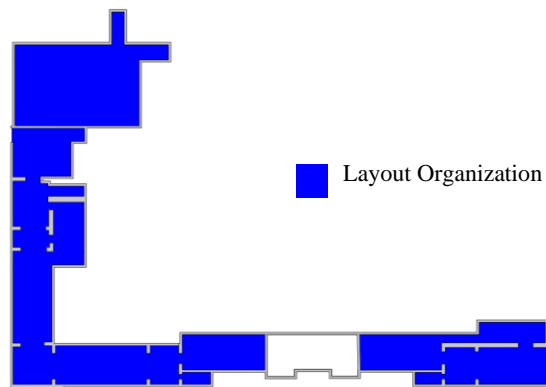

Figure 4.52: Floor -1, Linear Organization, V & A Museum

The Ground Floor (0) has a Radial Type of organization because of the central zone (Lobby, Garden) and the rest of the zones that arranged in a linear organization. (Figure 4.53).

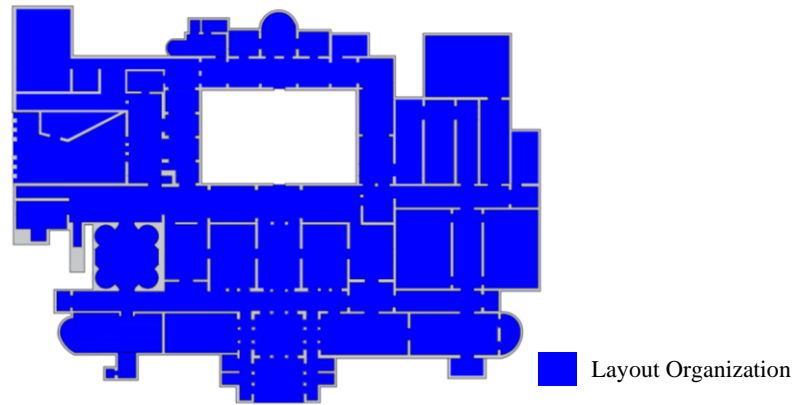

Figure 4.53: Floor 0, Radial Organization, V & A Museum

Floor 1 shows two main straight line and the zones are arranged along the length of the layout, which sorted the organization as a linear type (Figure 4.54).

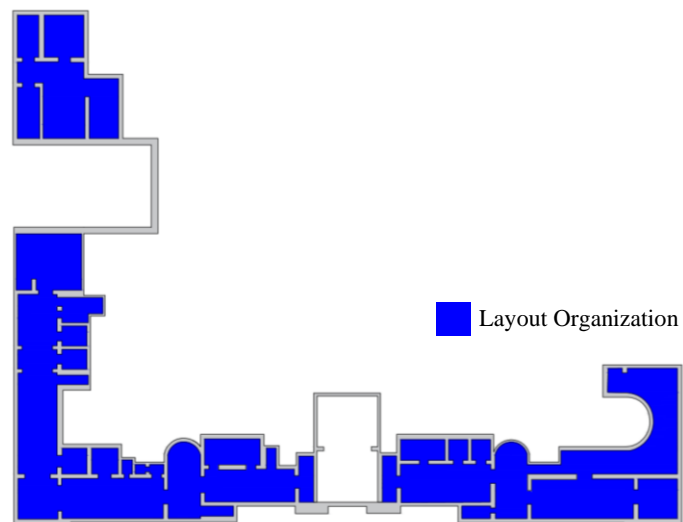

Figure 4.54: Floor 1, Linear Organization, V & A Museum

In the Floor 2 the central garden appears and lead to arrange the exhibitions halls around it in their own linear organization type (Figure 4.55).

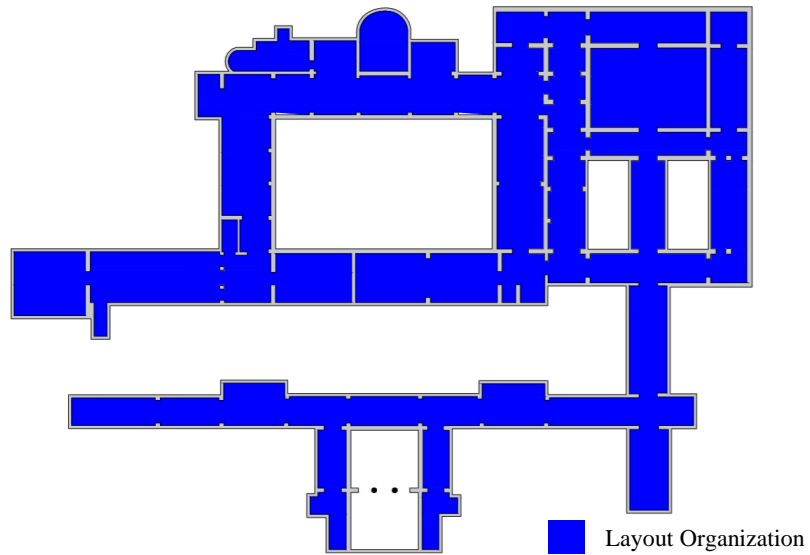

Figure 4.55: Floor 2, Linear Organization, V & A Museum

Floors 3 & 4 present a linear type of organization within the straight functions that have been designed the internal space (Figure 4.56 & Figure 4.57).

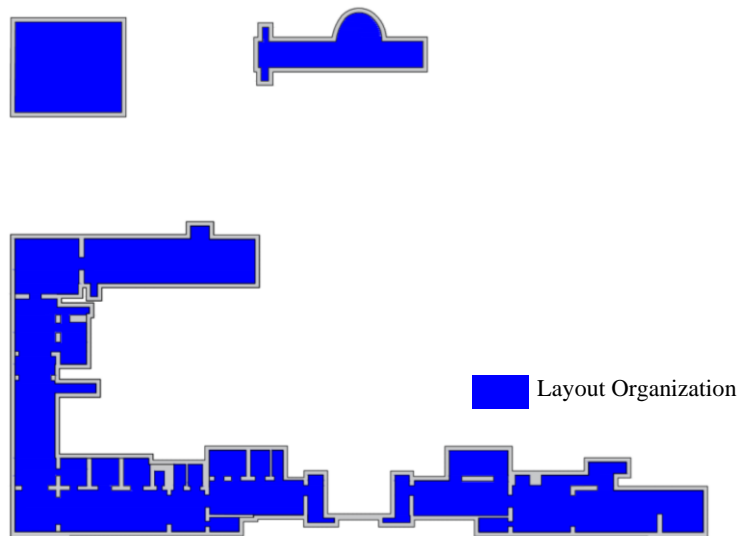

Figure 4.56: Floor 3, Linear Organization, V & A Museum

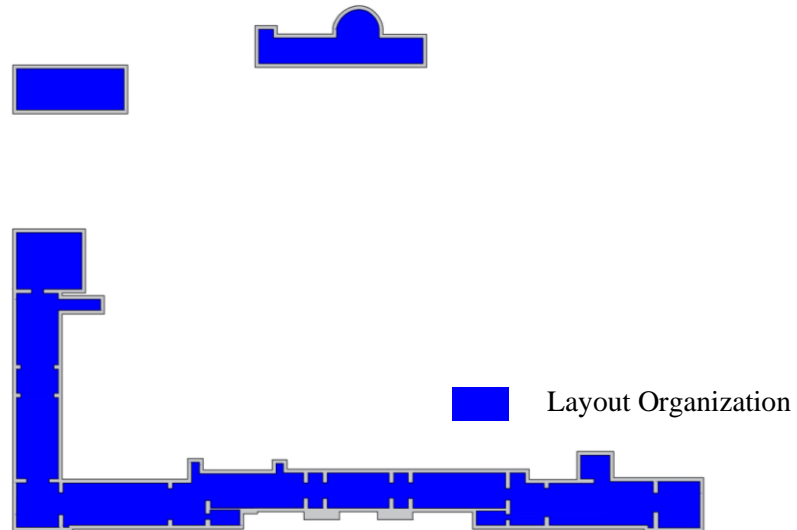

Figure 4.57: Floor 4, Linear Organization, V & A Museum

➤ **Accessibility (access points) and Zoning (exhibited space & foyer).**

Entering the museums through the “Tunnel Entrance” which is located Floor -1. In the layout there are one foyer. All the vertical access points: Stairs & Lifts works as a starting point for the visitor journey (Figure 4.58).

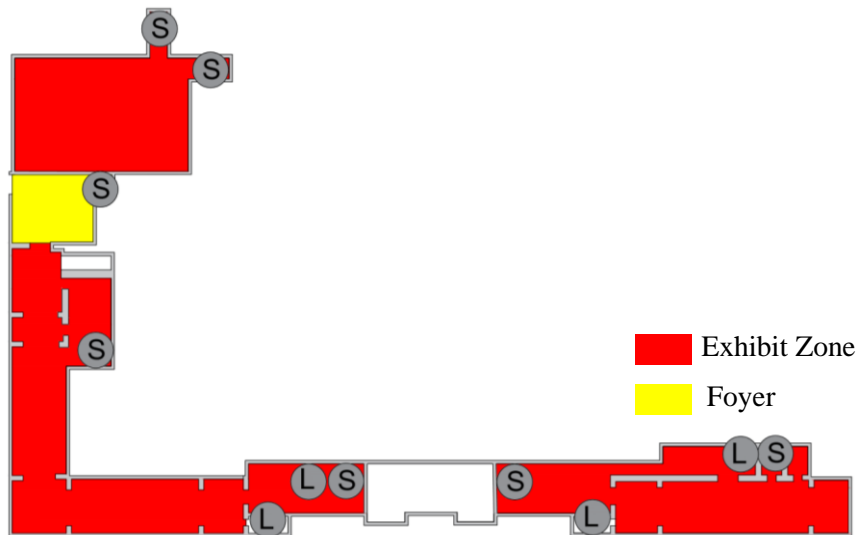

Figure 4.58: Floor -1, Access points, Exhibitions area & Lobbies, V & A Museum

Ground Floor (0) has two entrances from the front elevation “Cromwell Road Entrance” & from the side “Exhibition Road Entrance” both entrances opened to a foyer which include services like: shop, cafes and lead to the exhibition’s wings. Furthermore, the Ground floor include another 3 foyers. The vertical access points that connect the Floors of the whole building are distributed within the layout: Stairs & Lifts and sited as starting points (Figure 4.59).

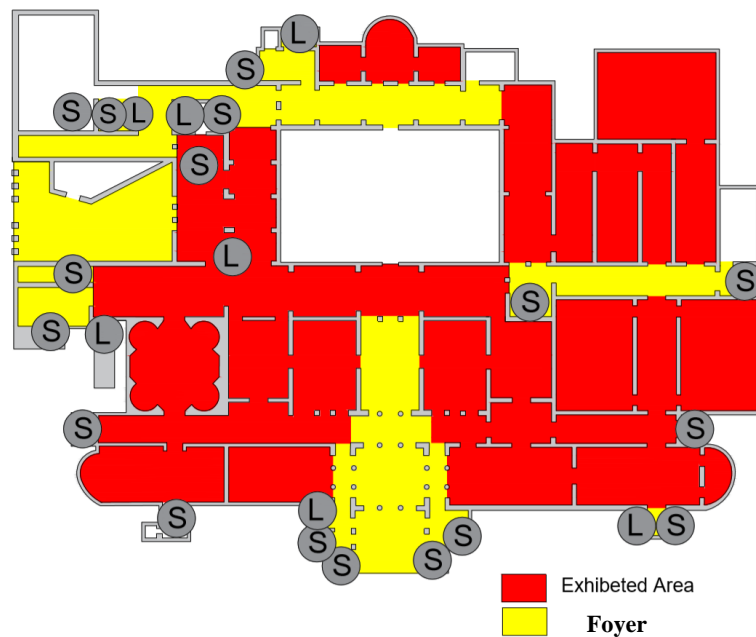

Figure 4.59: Floor 0, Access points, Exhibitions area & Lobbies, V & A Museum

Floor 1 has no any certain space work as a foyer although the access points are distributed within the layout: Stairs & Lifts (Figure 4.60).

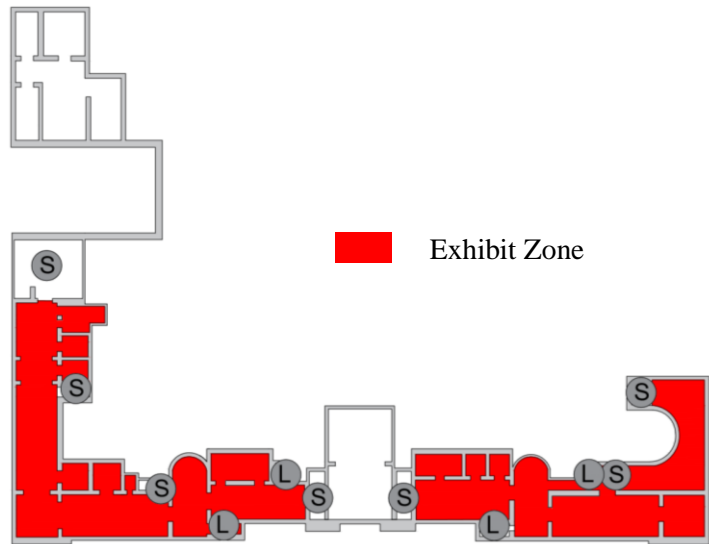

Figure 4.60: Floor 1, Access points, Exhibitions area & Lobbies, V & A Museum

Floor 2 has a layout with various access points: stairs & Lifts located as a part of foyer or standalone creating the starting point for the visitor experience between the displayed items (Figure 4.61).

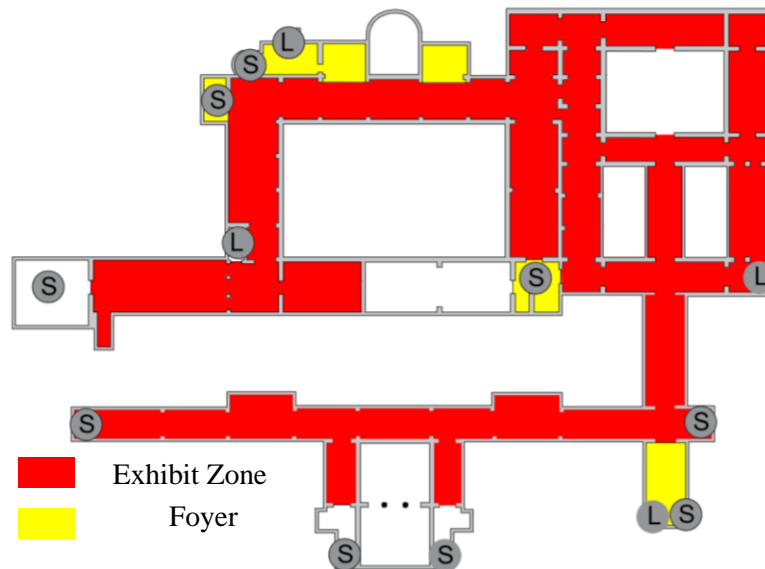

Figure 4.61: Floor 2, Access points, Exhibitions area & Lobbies, V & A Museum

Floor 3 & 4 can be reach vertically through the access points: Stairs & Lifts. In Floor 3 there are four foyers, However, in floor 4 there are only two (Figure 4.62 & Figure 4.63).

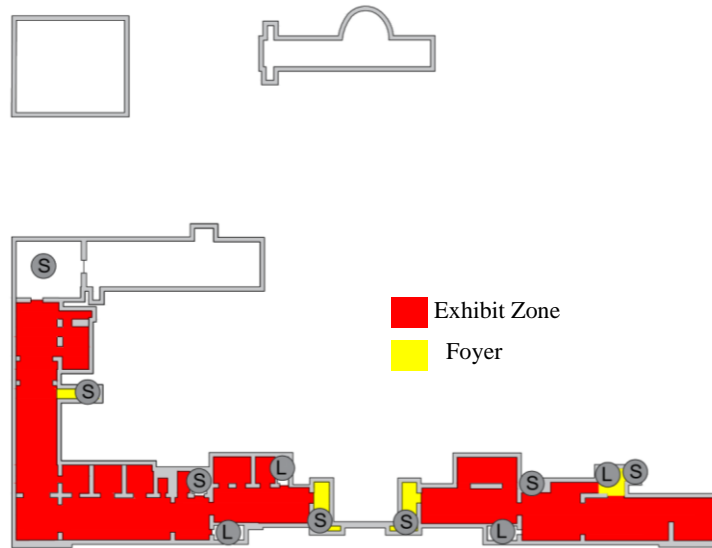

Figure 4.62: Floor 3, Access points, Exhibitions area & Lobbies, V & A Museum

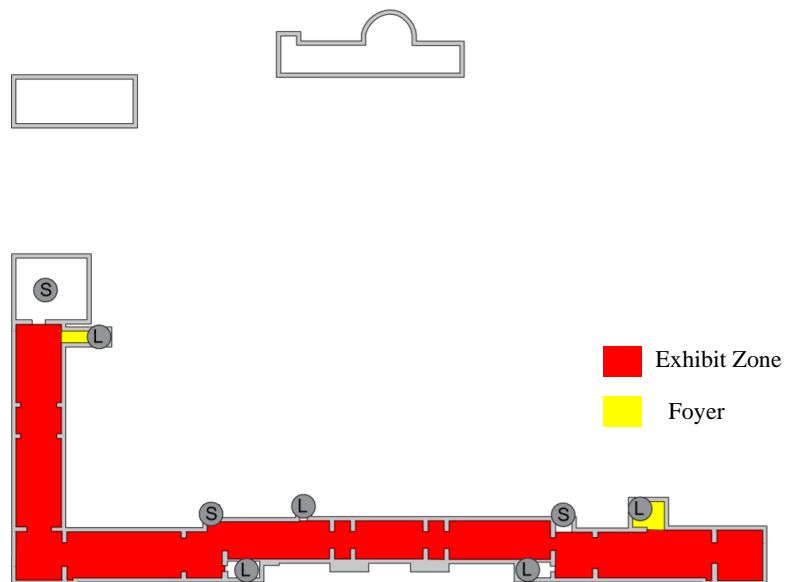

Figure 4.63: Floor 4, Access points, Exhibitions area & Lobbies, V & A Museum

➤ **Pathway-Layout Relation**

The analysis of Linear type organization for Floor -1, shows a “Linear Procession” type of relation between layout and pathway (Figure 4.64).

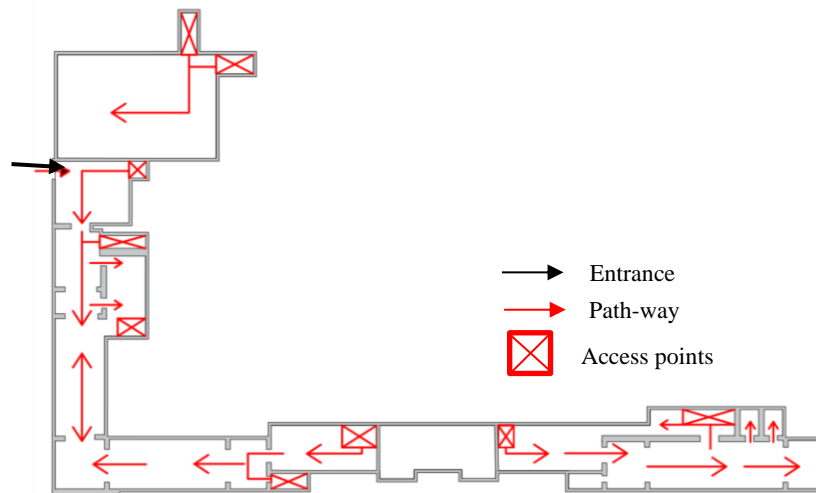

Figure 4.64: Floor-1, Linear Procession, V & A Museum

Ground Floor (0) present a various type of pathway. It shows a Linear, Loop & Core type of relation between the pathway & layout design. Together sorted under the “Complex Type” (Figure 4.65).

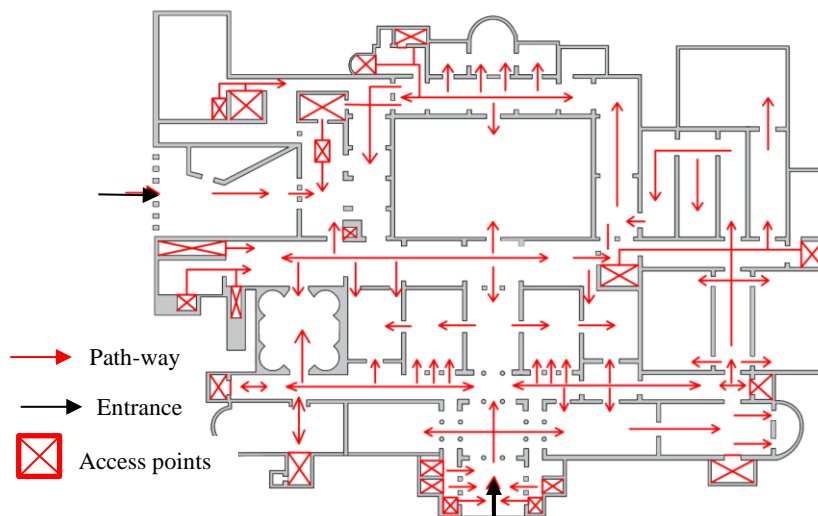

Figure 4.65: Floor 0, Complex Type, V & A Museum

Floor 1 has a Linear pathway along the length of the layout. Defined as a Linear Procession (Figure 4.66).

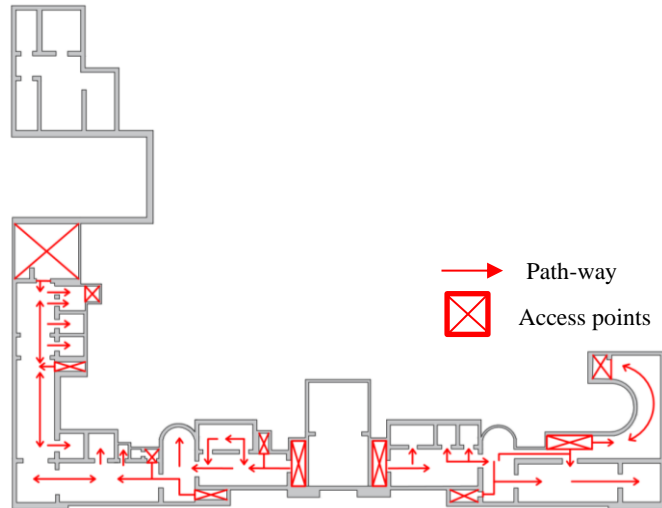

Figure 4.66: Floor 1, Linear Procession, V & A Museum

Floor 2 & 3 & 4 have the same Linear organization which reflect a Linear Procession type of relation (Figure 4.67, Figure 4.68 & Figure 4.69).

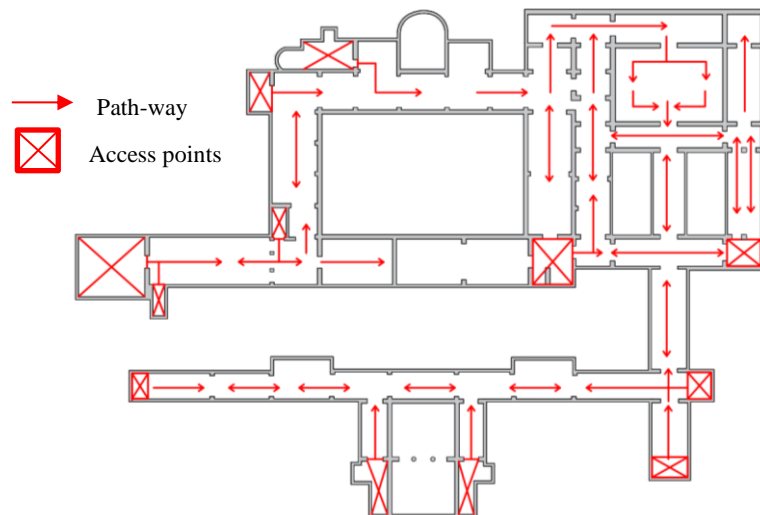

Figure 4.67: Floor 2, Linear Procession, V & A Museum

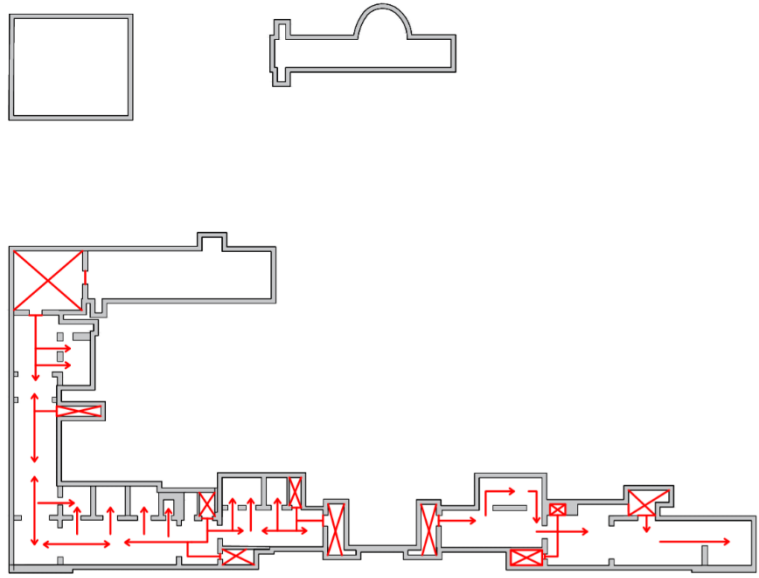

Figure 4.68: Floor 3, Linear Procession, V & A Museum

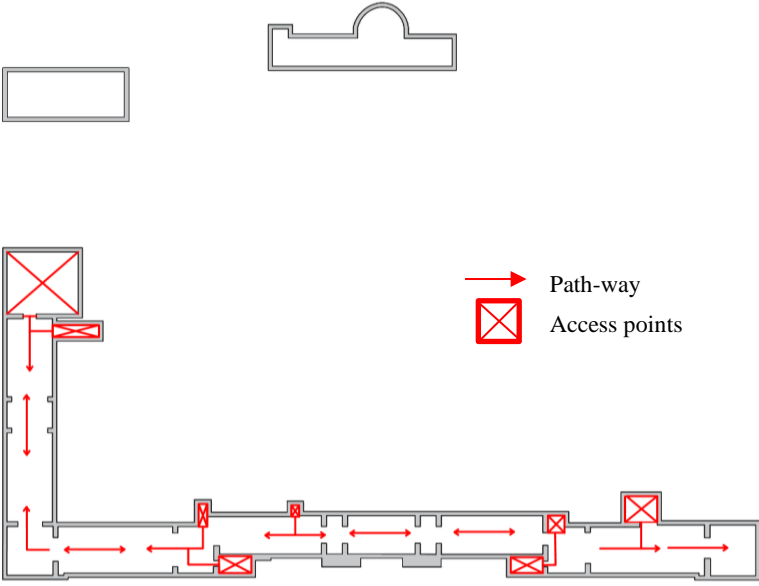

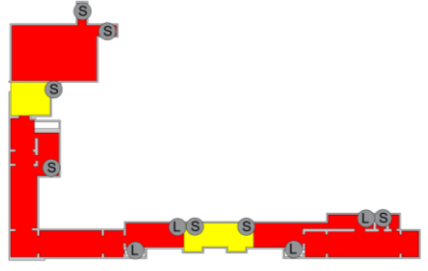
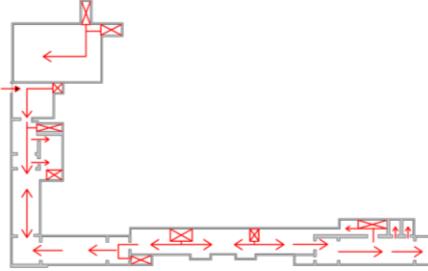
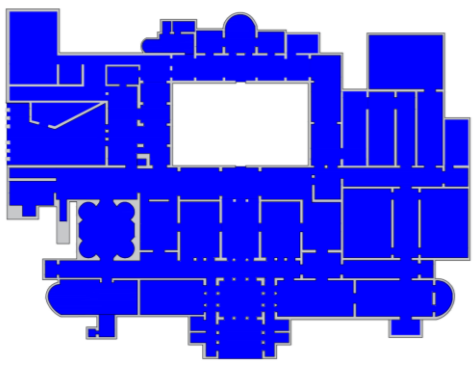
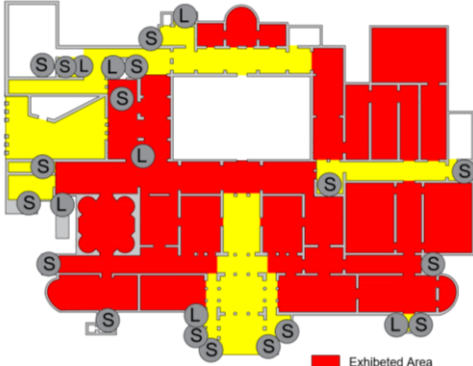
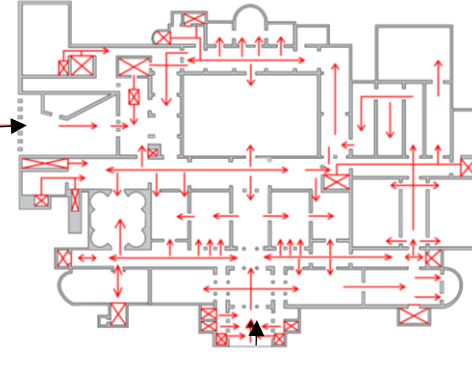
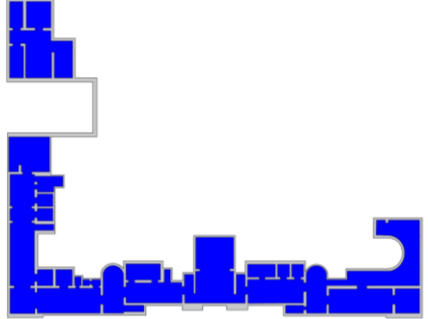
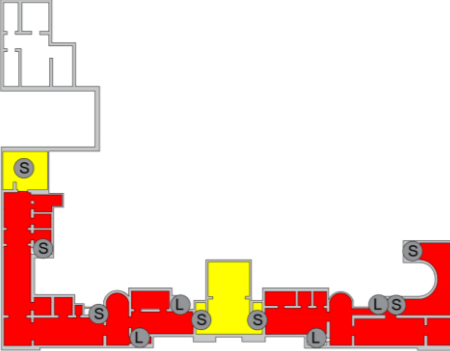
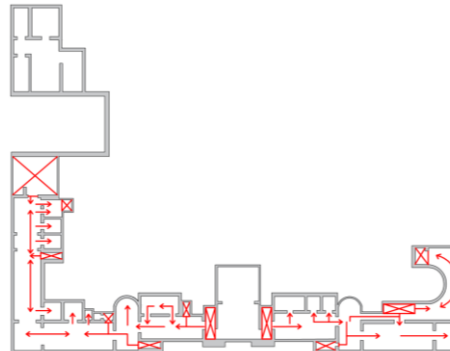
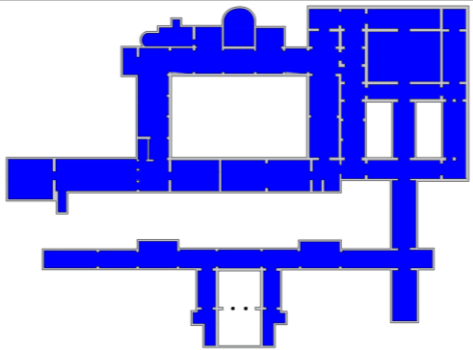
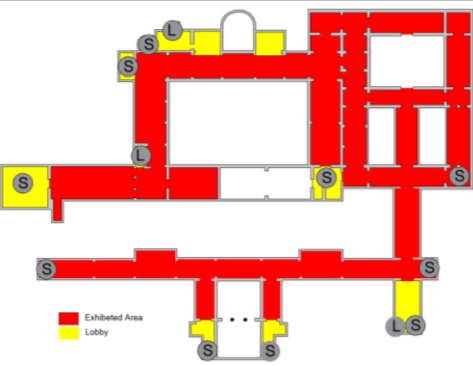
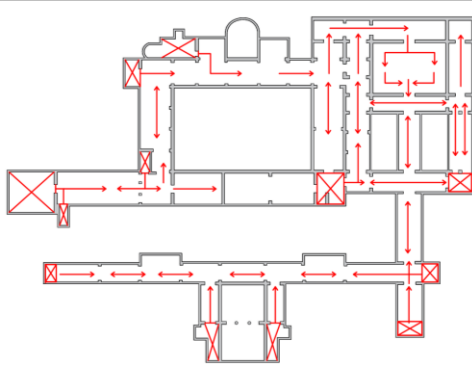

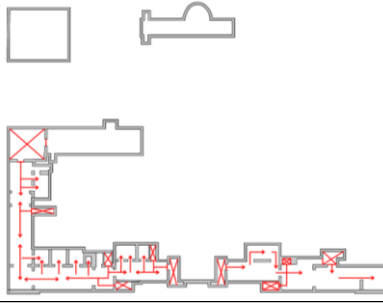
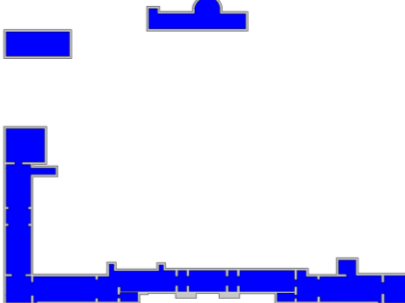
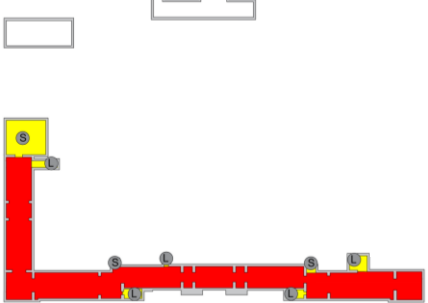
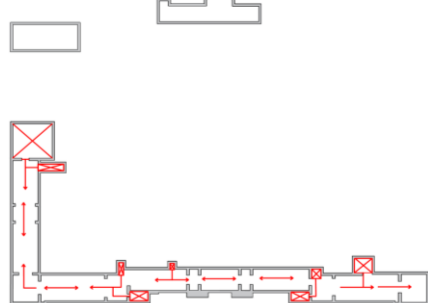

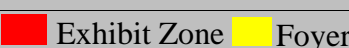
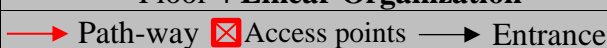

Figure 4.69: Floor 4, Linear Procession, V & A Museum

➤ **Summary of Victoria & Albert Museums Layout Analysis**

The spatial organization of Victoria & Albert Museum have similarities in five floors of the whole six levels. Floors (-1,1,2,3,4) have the same Linear Organization type. The Ground Floor has a different spatial organization a Radial Organization type. There are three Entrances of the Building. Two of them are located in the Ground floor and the last one part of Floor -1 through a tunnel. The building has main foyer located under the Dome in the ground floor. Secondary foyers distributed within the six floors. Moving vertically throughout the access points: Stairs & Lifts which also worked as a starting points for the visitor's journey. Reaching that the relation between pathway & layout are Linear Procession if the floor & the ground floor reflect a Complex type. The inventory table Layout Analysis of V&B Six Floors (Table 4.12).

Table 4.12: Layout Analysis of V & A Museum Six Floors

LAYOUT ANALYSIS OF V & A MUSEUM SIX FLOORS		
Layout organization	Access points, Exhibitions' area & Foyers	Type of relation (pathway-layout)
		
Floor -1 Linear Organization		Floor -1 Linear Procession
		
Floor 0 Radial Organization		Floor 0 Complex Type
		
Floor 1 Linear Organization		Floor 1 Linear Organization
		
Floor 2 Linear Organization		Floor 2 Linear Organization
		
Floor 3 Linear Organization		Floor 3 Linear Organization
		
Floor 4 Linear Organization	S Stair L Lift	Floor 4 Linear Organization
 Layout Organization	 Exhibit Zone Foyer	 Path-way Access points Entrance

4.4 Finding

The six selected case studies received millions of international visitors yearly and they are the most crowded museums in the European context within a historical building. The spatial organization for adaptively-reused historical building serves all the visitors. Due to the preservation of the heritage value designer face limitation. This research find that designer incur the problem by adding an architectural element to the original building. In the Louvre Museum the designer adds the pyramid which works as a foyer rich of various access points and create a Radial type of organization which is the most effective in crowd solution. In Victory & Albert Museum appears a second Entrance as part of outdoor yard. This addition contributed easing the crowds at the main entrance.

The “Introduction Table” illustrate that the majority of the exhibition area in indoor spaces, however, all the museums sites include outdoor areas. The crowds can be reduced while using the outdoor zone as exhibition area. The circulation routes will be more varied and without walls or partitions limited the movement of the visitors. Also, the tables present that each of the museums has its own specialties zones as a wing or a certain object. Furthermore, an “Educational Area” which may include a seminar room, conference room, theatre & creative studio, has been seen in all museums. Undoubtedly, all interior spaces have regular services like toilets, shops & cafes. The research noticed that the negative impact for the crowd is “Waiting Time” can be investigated in the Educational or Service areas.

The last information by the “Introduction Tables” is Crowd Density. The numbers present the relation between the number for average visitors per day on the number of totally area in the museum for the year of 2018. The results have arranged the case studies in different manner comparing to the list of “Most visited Museum”, However, Louvre Museum remains in the beginning as the most crowd density building with 0.46 people per meter square (Figure 4.70).

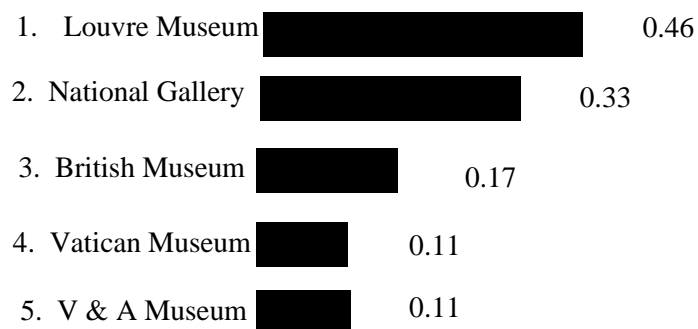

Figure 4.70: Crowd Density for Five Case Studies

The research finds that the most floors face crowds problem are Floor 0 & Floor 1 in the Louvre Museum, here there are three exhibited wings with no any main foyers, and linear type of organization which offer only linear procession toward the circulation routes, comparing with the same museum floor -2 & floor -1 have foyers with less of exhibited space and floor -1 has the additional pyramid which offer Radial organization type with Core circulation routes that create three options for the visitors Each of the three-circulation option has access points. All that works as solutions to reduce crowd problem in floor -2 & -1. review (Table 4.13).

The “Layout Analysis Tables”, throughout the three main aspects: Type of Layout Organization, Access Points, Exhibitions Area & Foyers, and the Relation Between Pathway-Layout which considered as circulation routes. This thesis finds that Layout Organization differs between levels in the same Museum. Example of the British Museum, each floor by considering the crowds and the extend exhibited zones has arranged the floor as need it. In the Ground Floor where the Entrance there is one main big foyer as “Great Court” in the middle and the exhibition zones arranged around it with a Radial type of organization that designed Core circulation routes. These routes offer various options towards the visitors which works to ease the crowd movements. However, the extend of the exhibited space on the upper floor is less, Here the type is centralized organization which offers a Loop circulation route with one smaller foyer. The Lower floor has a limited exhibited space with liner procession and liner organization type. The difference between the floors in same building work in effective solutions for the gathering issues.

Four of the historical buildings that have been studied contain more than one Entrance leading to its interior space. Certainly, that works in a better way for pressure relief on the Entrances. In general, foyers play a key role in leading people within the interior space and all the exhibited halls linked with the main foyer. The main foyers created a central zone between the exhibited halls on the same floors that have the entrance. Finding that it is a critical area that includes the Services & oriented function for the visitor while entering the building.

These case studies illustrate that layouts have also secondary foyers that are smaller in sizes and contain the access points distributed within the floors. Access points considered as a starting point for the visitor journey example of Stairs & Lifts which

are common between the whole six buildings. Additionally, Escalator has been seen only in Louvre and Vatican Museums deal with a bigger number of visitors which participate to reduce the gathering issues in the foyers.

The final aspect that analyses the floors & level through the perspective of pathway-layout relation appears various types in the same case study. the Complex type which has a Core, linear and loop pathways funded in the Ground floor of both National Gallery & Victory & Albert Museums within the Radial organization type. The inventory table for the six museums (Table 4.13).

Table 4.13: The Inventory Table for the Six Museums.

LAYOUT ANALYSIS OF LOUVRE MUSEUM FIVE FLOORS			LAYOUT ANALYSIS OF V & A MUSEUM SIX FLOORS		
Layout organization	Access points, Exhibitions' area & Foyers	Type of relation (pathway-layout)	Layout organization	Access points, Exhibitions' area & Foyers	Type of relation (pathway-layout)
Floor -2, Linear Organization Type		Floor -2, Linear Procession	Floor -1 Linear Organization		Floor -1 Linear Procession
Floor -1, Radial Organization Type		Floor -1, Core	Floor 0 Radial Organization		Floor 0 Complex Type
Floor 0, Linear Organization Type		Floor 0, Linear Procession	Floor 1 Linear Organization		Floor 1 Linear Organization
Floor 1, Linear organization Type		Floor 1, Linear Procession	Floor 2 Linear Organization		Floor 2 Linear Organization
Floor 2, Linear Organization Type		Floor 2, Linear Procession	Floor 3 Linear Organization		Floor 3 Linear Organization
			LAYOUT ANALYSIS OF VATICAN MUSEUM THREE FLOORS		
			Layout organization	Access points, Exhibitions' area & Foyers	Type of relation (pathway-layout)
			Lower Floor Linear Organization Type		Lower Floor Linear Procession Type
			Upper Floor Linear Organization Type		Upper Floor Linear Procession Type
			Basement Floor Linear Organization Type		Basement Floor Linear Procession Type
LAYOUT ANALYSIS OF BRITISH MUSEUM THREE FLOORS					
Layout organization	Access points, Exhibitions' area & Foyers	Type of relation (pathway-layout)			
Ground Floor levels (0, -1, 1, 2), Radial Organization Type		Ground Floor levels (0, -1, 1, 2), Core Type			
Upper Floor levels (3, 4, 5) Centralized Organization Type		Upper Floor levels (3, 4, 5) Loop Type			
Lower Floor levels (-1, -2) Linear Organization Type		Lower Floor levels (-1, -2) Linear Procession Type			
			LAYOUT ANALYSIS OF NATIONAL GALLERY THREE OF THE FLOORS		
			Layout organization	Access points, Exhibitions' area & Foyers	Type of relation (pathway-layout)
			Floor -2 Linear Organization Type		Floor -2 Linear Procession
			Ground Floor Radial Organization Type		Ground Floor Complex Type
			Floor 2 Radial Organization Type		Floor 2 Core Type

Chapter 5

CONCLUSION

Museums all over the world participate in the same functional role. Their major aim is to present the culture, and history of the nation by preserving and displaying various artworks and objects. In this thesis, the most visited museums within the historical European context have analyzed from the perspective of the spatial organization by emphasizing the crowd issue in regards to the areas of the museums and the number of visitors. Aiming to figure out a spatial organization that avoids the crowd's problem, therefore, finding out circulation routes between and inside the halls that can discount the gathering issues. The study considers the importance of a smooth pathway within interior space along with clear, various access points between the floors, leading the visitor to have a successful journey without losing time, or information due to any gathering on the pathways between the exhibition halls.

Concluding with the answers to the thesis questions; How the spatial organization of the museums affects the circulation routes? What sort of layout can avoid the crowd's issues on the circulation routes? Based on the theory and the analysis of the six museums case studies; The spatial organization for the floors means the arrangement of the zones in the layout and what function does it require. This arrangement includes creating a relation between the zones. These relations considered as wayfinding or pathways. In Museum the exhibition area in the main zone, however, foyers, access points, and services contribute together to serve the visitors in the internal space. The

relation between this component create directly the circulation routes. It creates the pattern of movement in the internal space of the Museum. Therefore, this research answers that the spatial organization affects strongly and directly the pattern of circulation routes. This research illustrated in the "Analysis Tables" the relation between layout organization and pathway pattern and sorted the types.

The answer of the second question and after considering & analyzing the most visited museums and the high crowd density spaces is the following; the Radial Type Organization can be considered as the layout that can avoid the crowd's issues on the circulation routes. The Radial type organization can reflect the Complex circulation routes of; Core, Loop & Linear, so it offers the visitors many pathway options in the internal spaces. The layout which has an exhibited outdoor area gives the chance to the visitors to create an unlimited pathway by walls or Partition. Crowd routes control can be done also by including the layout more than one Entrance. with emphasizing to have in the layout the following function; the main foyer and secondary foyers including various access points (lifts, Escalators & Stairs).

For further studies, can be the question and the focuses of circulation routes by studying the vertically drawings of the building. The findings mentioned in chapter four can be considered and expanded into recommendations for designer who design the museums from scratch or who works with adaptive reuse method:

1. Floors with Radial Organization type offers a Complex of Core, Loop & Linear Procession pathway, which is effective solution to circulation routes in the main floor with Entrances.
2. On some levels, the linear type of organization is part of the preservation limitations of the historical building, the alternative here to have various forms and number of access point examples in Louvre Museums floors (0, 1,2,).
3. Waiting Time can be investigated in watching documentaries movies, workshops & seminars in the educational zone but it is advisable to locate it nearby the most crowds' halls with its own foyer.
4. Due to the new situation of COVID-19, museums that have outdoor area & semi-outdoor area can be used as an exhibition area to reduce crowds and for proper ventilation.

REFERENCES

- Adrian Cave. (2007). The use of historic buildings as museums and art galleries. Retrieved 18 July 2020, from : <https://www.environment.nsw.gov.au/resources/heritagebranch/heritage/justbecause.pdf>
- Alexander, E. P. (1979). *Museums in motion: An introduction to the history and functions of museums* (2nd ed.). Nashville: Altamira press.
- Ambrose, T. & Paine, C. (1993). *Museum Basics*. London & New York: ICOM and Routledge.
- Ancient World Wonder. (2003). *Bibliotheca Alexandrina*. Retrieved from: <https://www.ancientworldwonders.com/library-alexandria-bibliotheca-alexandrina.html>
- Anderson, J. (1984). *Time Machines: The world of Living History*. Nashville: Armand Colin Association for State and Local History.
- B.O.H. (n. d). "The Exhibition Building of 1862," in *Survey of London: Volume 38, South Kensington Museums Area*, ed. F H W Sheppard (London: London County Council, 1975), 137-147. *British History Online*, Retrieved July 25, 2020 from: <http://www.british-history.ac.uk/survey-london/vol38/pp137-147>.

Beirne, S. (2003). Suzie Beirne m.d.i.a. Usenature (Usenature.com).

Berti, M., & Costa.V. (2009). the Ancient Library of Alexandria: A Model for

Bianchini , R. (2019). Vatican Museums, Rome. Retrieved 21 June 2020, from the
World Wide Web <https://www.inexhibit.com/mymuseum/vatican-museums-rome/>

Black, G. (2005). Engaging Museum (Developing Museums for Visitors Involvement)
(6th Edition ed. Vol. 2). New York: Routledge.

Bonet, L. (2007). *Renovating for Living. Barcelona*: Loft Publications.

Brebbia, C. A. & Hernández, C. (2015). *Structural studies, repairs and maintenance of heritage architecture XIV* (Vol. 153). WIT press.

British Museum. Blog. Official Web Site. Retrieved 20 June 2020, from:
<https://www.britishmuseum.org/about-us/british-museum-story/architecture>

Burcaw, G. E. (1983). Introduction to museum work. Nashville: American

Chee, M. (2019). 2018 TEA/AECOM Theme Index and Museum Index reveals
world's most popular theme parks, water parks and museums. Retrieved 15
July 2020, from the World Wide Web : <https://aecom.com/press-releases/aecom-and-teas-definitive-global-report-shows-attendance-at->

themed-attractions-has-exceeded-a-half-billion-visits-for-the-first-time-in-history/

Dernie David (2006). *Exhibition Design*. W. W. Norton & Company. ISBN 978-0-393-73211-5.

Douglas, J. (2006). *Building adaptation*. Published by Elsevier Ltd.

Elizabeth Rodini.(n.d).A brief history of the art museum. Retrieved 9 August 2020.From: <https://www.khanacademy.org/humanities/approaches-to-art-history/tools-for-understanding-museums/museums-in-history/a/a-brief-history-of-the-art-museum-edit>

Elottol, R., & Bahauddin, A. (2011). Practical Step towards integrating Elderly Pathway Design into Museum Space planning Framework of Satisfaction Assessment. *International Transaction journal of Engineering, Management and Applied Sciences and Technologies*, 2(3), 265-285.

Geoffrey D. Lewis. (2019). Museum. Retrieved: 8 August 2020, From: <https://www.britannica.com/topic/museum-cultural-institution>

Gill, J. (2016). The History of London's National Gallery In 1 Minute. Retrieved 6 July 2020, from: <https://theculturetrip.com/europe/united-kingdom/england/london/articles/history-of-the-national-gallery-london/>

- Günay, B. (2012). Museum concept from past to present and importance of museums as centers of art education. *Procedia-Social and Behavioral Sciences*, 55, 1250-1258.
- Henderson, J. (2001). In: Sun Shuo, (Ed), Trans. Museum Architecture. China Light Industry Press, Beijing.
- Hooper Greenhill, E. (1992). *Museums and the Shaping of Knowledge*. London: Routledge, <https://doi.org/10.4324/9780203415825>
- Hooper-Greenhill Ding Xiaoyu .(2010) .Architectural Space and Exhibition Design of Museums , *Archi Creation* ,no, pp.164-171.
- Hsu, L. (2004). Circulation in Museums. 2(3), 122-150
- Kelly, L. (2010, June 8). Australian Museum. Retrieved from: <http://australianmuseum.net.au/blogpost/Museullaneous/The-role-of>
- Kit (2014). “Pyramid” Project Launch. Christine Cuny
- Lehman, K. F. (2008). *Museum history and development* (Doctoral dissertation, University of Tasmania).
- Li, Z., Wei, Q., & He, H. (2013). A brief analysis of spatial constitution and functional organization of museum architecture: A case study on museums in Hefei. *Frontiers of Architectural Research*, 2(3), 354-361.

Matthews, G. M. (1991). *Museums and art galleries: a design and development guide*.
Butterworth Architecture.

Mornement, (2007). *Extensions*. London: Laurence King Publishing

Morris, D. (1962). *The Biology of Art*. New York: Alfred A. Knopf.

Murray, D. (1904). *Museums, their history and their use: with a bibliography and list of museums in the United Kingdom (Vol. 2)*. James MacLehose and Sons, publishers to the University. museum—7298

Museums and Galleries Foundation of NSW. (2004). *Just because it's old: of NSW museums and galleries in heritage buildings*. Retrieved 18 July 2020, from: <https://www.environment.nsw.gov.au/resources/heritagebranch/heritage/justbecause.pdf>

National Gallery (2020). *About the Building*. Retrieved 6 July 2020, from: <https://www.nationalgallery.org.uk/about-us/history/about-the-building>

Nicholson, Freda H. (2020) "Science Museums." *Dictionary of American History*. Retrieved August 05, 2020, from Encyclopedia.com: <https://www.encyclopedia.com/history/dictionaries-thesauruses-pictures-and-press-releases/science-museums>

Nikolić, O., Petronijević, A. M., & Nikolic, V (2018) . THE ROLE OF THE ARCHITECT IN THE SPATIAL AND FUNCTIONAL ORGANIZATION OF THE MUSEUM EXHIBITION.

Panero, J. (2012). What's a museum? *The New Criterion*,

Physick, John (1982). *The Victoria and Albert Museum: The History of its Building*

Ripley, D. (1970). *The Sacred Grove: museums and their evolution*. Victor Gollancz.

Rohloff, I. K., Psarra, S., & Wineman, J. (2009). Experiencing museum gallery layouts through local and global visibility properties in morphology: An inquiry on the YCBA, the MoMA and the HMA. In *the 7th International Space Syntax Symposium* (Vol. 7, No. 2, pp. 94-108).

Senior, J. (2005). the Rise of Museums. Retrieved 9 August 2020. From: <https://www.open.edu/openlearn/history-the-arts/history/the-rise-museums>

Still, K. (2019). Crowd Safety & Crowd Risk Analysis. Retrieved: 10 Sept 2020

Szalay, J. (2018). The Louvre Museum: Facts, Paintings & Tickets. Retrieved 20 June 2020, from the World Wide Web : <https://www.livescience.com/31935-louvre-museum.html#:~:text=History%20of%20the%20Louvre,a%20blogger%20at%20Culture%20Tourist>.

The Editors of Encyclopedia Britannica (2020). British Museum. Retrieved 20 June 2020, from the World Wide Web: <https://www.britannica.com/biography/Richard-Garnett>

The Editors of Encyclopedia Britannica (2020). Louvre Museum. Retrieved 16 June 2020, from the World Wide Web: <https://www.britannica.com/topic/Louvre-Museum>

Tzortzi, K. (2007). MUSEUM BUILDING DESIGN AND EXHIBITION LAYOUT: patterns of interaction. The Bartlett School of Graduate Studies, UCL

U.N.D.P (1999), *International Conference on The Revitalization of Historic Cities*. 20-22 May 1999, Nicosia

V& A Museum (2019). Building the Museum. Queen Victoria & Prince Albert's Bicentenary Retrieved 28 June 2020, from: <https://www.vam.ac.uk/articles/building-the-museum>

Virginia Association of Museum. (n.d). Types of Museums. Retrieved 8 August 2020. From <https://www.vamuseums.org/>

Wisconsin Historical Society. (2020). Is your building historic? Retrieved: 18 July 2020, From: <https://www.wisconsinhistory.org/Records/Article/CS4168>

Yan, Y. (2009). The Museum Indoor Traffic Scheme, Sichuan Building Science.no.5, pp. 210-214 (chapter 35).

URL 1. Retrieved 9 August 2020. From: <https://www.britannica.com/topic/Louvre-Museum>

URL 2. Retrieved 9 August 2020. From: <https://www.britannica.com/topic/Tate-galleries>

URL 3. Retrieved 9 August 2020. From: <https://culture-communication.fr/en/how-museum-visitors-became-consumers/>

URL 4: http://geologi.snm.ku.dk/english/about_the_geological_museum/

URL 5. Retrieved 9 August 2020. From : <https://depositphotos.com/186680204/stock-photo-view-historical-center-rome-height.html>

URL 6. Retrieved 9 August 2020. From: <https://blog.britishmuseum.org/why-15-january/>

URL 7. Retrieved 9 August 2020. From: https://commons.wikimedia.org/wiki/File:Microcosm_of_London_Plate_047_-_King%27s_Mews.jpg

URL 8. Retrieved 9 August 2020. From: https://en.wikipedia.org/wiki/Carlton_House

URL 9. Retrieved 9 August 2020. From: <https://www.buildington.co.uk/london-sw7/cromwell-road/waterhouse-building-natural-history-museum/id/841>

URL 10. Retrieved 9 August 2020. From:
https://en.wikipedia.org/wiki/1862_International_Exhibition

URL 11. Retrieved 9 August 2020. From: <http://www.wildlifeandtravel.com/the-natural-history-museum-kensington-london-my-happy-place/>

URL 12. Retrieved 9 August 2020. From: <https://www.british-history.ac.uk/survey-london/vol38/pp201-216>

URL 13. Retrieved 9 August 2020. From: <https://www.nhm.ac.uk/visit/galleries-and-museum-map.html>

URL 14. Retrieved 9 August 2020. From:
<http://collections.vam.ac.uk/item/O1092841/exterior-view-of-brompton-park-photograph-thompson-charles-thurston/>