

Roof Defects in North Cyprus

Shadi Pakpour Aghghaleh

Submitted to the
Institute of Graduate Studies and Research
in partial fulfillment of the requirements for the Degree of

Master of Science
in
Architecture

Eastern Mediterranean University
February 2015
Gazimağusa, North Cyprus

Approval of the Institute of Graduate Studies and Research

Prof. Dr. Serhan Çiftçiođlu
Acting Director

I certify that this thesis satisfies the requirements as a thesis for the degree of Master of Science in Architecture.

Prof. Dr. Özgür Dinçyürek
Chair, Department of Architecture

We certify that we have read this thesis and that in our opinion it is fully adequate in scope and quality as a thesis for the degree of Master of Science in Architecture.

Asst. Prof. Dr. Halil Zafer Alibaba
Supervisor

Examining Committee

1. Asst. Prof. Dr. Halil Zafer Alibaba

2. Asst. Prof. Dr. Polat Hançer

3. Asst. Prof. Dr. Pınar Uluçay

ABSTRACT

The construction boom in North Cyprus, followed by Annan Plan, have resulted in the construction of a great number of buildings with minimum costs and quality. Although there exist certain rules for the construction of new buildings in North Cyprus, and part of these rules are related to the roofs, defects are observed few years after construction.

This thesis intends to introduce different roof systems in North Cyprus, to find their problems and suggest solutions. In this respect, Nicosia, Famagusta, Kyrenia, and Iskele districts in Northern Cyprus are selected as cases for this study. First, roofs are analyzed from form, structure, material, indoor air quality and thermal insulation, and construction details' aspects.

Form of roofs is being analyzed by Google Earth maps for urban and rural parts of the selected cases. Roof structures are analyzed by distributing close-ended questionnaires among architects, and constructors of the 20 chosen construction companies. Finally, 15 designed projects are selected and their materials, indoor air quality and thermal insulation, and construction details are discussed.

Owners, 5-6 years after occupation and constructors are asked to evaluate roof systems and to choose the most important problems in North Cyprus. The number of buildings which were constructed in the selected districts according to Devlet Planlama Örgütü in 2009 was 2064, thus; 326 owners from the urban and rural parts of these districts are randomly selected to fill the questionnaires.

By utilizing the results of observations and filled questionnaires, the root of roof defects in Northern Cyprus can be divided into poor design, construction and workmanship, and maintenance. Lack of proper details, thermal insulations, and drainage systems with improper sloping for flat roofs are caused by poor design.

Cockles, ridges and splits on roofing membrane, poor leveling and also slipped and loose tiles are common defects caused by poor workmanship. Other problems are related to the maintenance such as mold growth on roof tiles, placing various elements on roof, and broken and blocked gutters.

This thesis can be useful for constructors and designers, in order to minimize roof defects by proper design and construction and researchers who are interested in roofs and diagnosing their problems.

Keywords: Roof, roof defects, TRNC construction industry, building construction details, architectural design

ÖZ

Annan Planı'nın ardından Kuzey Kıbrıs'ta inşaat patlaması neticesinde birçok bina inşa edilmiştir. Çatı yapımı ile ilgili kuralların olmasına rağmen çok sayıda binada çatılarla ilgili problemler olduğu gözlemlenmiştir.

Bu tez, çatılarla ilgili sorunları bulmak ve çözüm önermek için hazırlanmıştır. Bu bağlamda, Lefkoşa, Gazimağusa, Girne ve İskele dahilindeki çatı sorunları irdelenmiştir. Öncelikle çatılar biçim, yapı malzemeleri, hijyen, ısı izolasyonu ve yapı detayları açısından analiz edilmiştir.

Mevcut çatılar Google Earth yardımı ile tesbit edilip daha sonra analiz edilmiştir. Çatı'ları analiz etmek için kapalı uçlu sorular içeren anketler hazırlanıp mimarlara ve müteahhitlere dağıtılmıştır. 20 adet müteahhit firma ile görüşme yapılmıştır. Seçilmiş firmalara ait 15 proje için analizler tamamlanmıştır.

Yapı sahiplerinden 326 kişi seçilip anket yapılmıştır. Yapı sahiplerine çatılar ile ilgili sorular sorulmuş ve memnuniyetleri ve memnuniyetsizlikleri analiz edilmiştir.

Gözlemlerin ve analizlerin sonucunda bulunan sonuçlara göre çatı sorunların temelinde kötü tasarım, zayıf işçilik ve tamirat, yanlış yapı detayı, ısı izolasyon uygulanması, yanlış su drenaj yapımı, az meyil yapımı bulunmuştur. Zayıf ve tecrübesiz işçi kullanımı sonucunda mahyalarda, meyillerde, kiremit montajında birçok sorun ortaya çıkmıştır.

Bu tez müteahhit firmalara, tasarımcılara çatılarla ilgili sorunları ortaya koymak ve çözüm önermesi açısından faydalı olacaktır.

Anahtar Kelimeler: Çatı, çatı sorunları, KKTC inşaat sektörü, yapı detayları, mimari tasarım

To

My mother MASOUMEH BAHRAMI

and

My father SALMAN PAKPOUR AGHGHALEH

ACKNOWLEDGEMENT

First and foremost, I would like to express my deepest gratitude to my supervisor, Assist. Prof. Dr. Zafer Halil Alibaba, who has supported me throughout my thesis with his patience and knowledge.

Furthermore, I would also like to acknowledge with much appreciation the crucial role of the construction companies in Northern Cyprus who have aided me by providing the required information.

I would like to thank my parents, elder sister Elnaz Pakpour Aghghaleh, and brother Armin Pakpour Aghghaleh, for supporting and encouraging me with their best wishes. Last but not least, I would like to thank Mehrdad Roudini, who as a good friend, was always willing to help and give his best suggestions.

TABLE OF CONTENTS

ABSTRACT	iii
ÖZ.....	v
DEDICATION.....	vii
ACKNOWLEDGEMENT.....	viii
LIST OF TABLES.....	xii
LIST OF FIGURES.....	xiv
1 INTRODUCTION.....	1
1.1 Introduction.....	1
1.2 Problem Statement.....	2
1.3 Aims and Objectives.....	2
1.4 Methodology of the Thesis.....	3
1.5 Limitation of the Thesis.....	7
1.6 Organization of Thesis.....	8
1.7 Literature Review.....	8
2 EVALUATION AND CATEGORIZATION OF ROOFS.....	19
2.1 Introduction.....	19
2.2 Roof Forms.....	20
2.2.1 Materials and Forms.....	25
2.2.2 Roof Form and Providing Energy.....	26
2.3 Roof Structures.....	26
2.3.1 Flat Roofs	27
2.3.2 Pitched Roofs.....	32
2.4 Indoor air quality and Thermal Comfort.....	41

2.4.1 Thermal Insulation.....	41
2.4.2 Air-tightness.....	44
2.4.3 Moisture Control.....	44
2.4.4 Roof Ventilation.....	45
2.4.5 Sound Insulation.....	47
2.4.6 Fire Protection.....	47
2.4.7 Corrosion Protection.....	48
2.5 Roof Materials.....	48
2.5.1 Concrete.....	49
2.5.2 Reinforced Concrete.....	50
2.5.3 Timber.....	51
2.5.4 Ferrous and Nonferrous Metals.....	54
2.5.5 Bituminous and Flat Roofing Materials.....	55
2.5.6 Roofing Tiles.....	58
2.5.7 Insulation Materials.....	58
2.6 Roofs' Construction Details.....	61
2.6.1 Flat Roof Construction Details.....	61
2.6.2 Pitched Roofs.....	72
2.7 Roofs' Design and Construction Standards.....	79
3 FINDINGS AND DISCUSSIONS.....	86
3.1 Evaluation Criteria for Roof Defects in North Cyprus.....	86
3.1.1 Selection of the Case Area.....	87
3.2 Analysis of Roof Forms in North Cyprus.....	89
3.3 Analysis of Roof Structures in North Cyprus.....	92
3.4 Analysis of Roof Materials in North Cyprus.....	93

3.5 Analysis of Roofs' Indoor air quality and Thermal Insulation in North Cyprus.....	94
3.6 Analysis of Roof Construction Details in North Cyprus.....	95
3.7 Evaluation of Roofs According to the Owners.....	99
3.8 Evaluation of Roofs According to the Constructors	101
3.9 Findings on Roof Defects According to the Designed Projects	102
3.10 Findings on Roof Defects According to the Owners.....	121
3.11 Findings on Roof Defects According to the Constructors.....	121
3.12 Discussions and Suggestions.....	122
4 CONCLUSION.....	138
REFERENCES.....	144
APPENDICES.....	154
Appendix A: Questionnaire for Constructors (English).....	155
Appendix B: Questionnaire for Constructors (Turkish).....	157
Appendix C: Questionnaire for Owners (English).....	159
Appendix D: Questionnaire for Owners (Turkish).....	161

LIST OF TABLES

Table 1. Definition of defect.....	10
Table 2. Roof defects (Hinks & Cook, 1997).....	16
Table 3. Roof components (Schunk et al., 2003).....	24
Table 4. Edges of a roof (Schunk et al., 2003).....	25
Table 5. Different types of flat metal roofs (Ching & Adams, 2001).....	31
Table 6. Form of trusses (Ching & Adams, 2001).....	40
Table 7. Typical profiles for sheet-steel roofing (Lyons, 2004).....	55
Table 8. Roof tiles, feature tiles and plain tile fittings (Lyons, 2004).....	59
Table 9. Construction details of a flat lead roof (Emmitt & Gorse, 2005).....	64
Table 10. Construction details of a bitumen-felt flat roof (Emmitt & Gorse, 2005).....	68
Table 11. Construction details of asphalt covering concrete flat roof (Emmitt & Gorse, 2005).....	69
Table 12. Construction details of different types of DPC (Emmitt & Gorse, 2005).....	71
Table 13. Different types of dormer windows (Emmitt & Gorse, 2005).....	73
Table 14. Construction details of plain tiles (Emmitt & Gorse, 2005).....	74
Table 15. Construction details of slates (Emmitt & Gorse, 2005).....	77
Table 16. Construction details of sheet metal covering (Emmitt & Gorse, 2005).....	78
Table 17. Analysis of roof materials in North Cyprus.....	94
Table 18. Analysis of roof details in North Cyprus.....	97
Table 19. Analysis of roof details in North Cyprus.....	98
Table 20. Discussions and suggestions for common flat roof defects in North Cyprus (Suggestions from Schunck, 2010).....	125

Table 21. Discussions and suggestions for common flat roof defects in North Cyprus (Suggestions from Schunck, 2010 and Özdeniz & Hançer, 2005).....	126
Table 22. Discussions and suggestions for common flat roof defects in North Cyprus (Suggestions from Schunck, 2010).....	127
Table 23. Discussions and suggestions for common flat roof defects in North Cyprus (Suggestions from Schunck, 2010).....	128
Table 24. Discussions and suggestions for common flat roof defects in North Cyprus (Suggestions from Schunck, 2010).....	129
Table 25. Discussions and suggestions for common flat roof defects in North Cyprus.....	130
Table 26. Guide for tables 20 to 25 (Schunck, 2010 and Özdeniz & Hançer, 2005).....	131
Table 27. Discussions and suggestions for common pitched roof defects in North Cyprus (Suggestions from Schunck & Oster, 2003 and Özdeniz & Hançer, 2005).	132
Table 28. Discussions and suggestions for common pitched roof defects in North Cyprus (Suggestions from Schunck & Oster, 2003)	133
Table 29. Discussions and suggestions for common pitched roof defects in North Cyprus (Suggestions from Schunck & Oster, 2003 and Özdeniz & Hançer, 2005).	134
Table 30. Discussions and suggestions for common pitched roof defects in North Cyprus (Suggestions from Schunck & Oster, 2003)	135
Table 31. Discussions and suggestions for common pitched roof defects in North Cyprus	136
Table 32. Guide for tables 27 to 31 (Suggestions from Schunck & Oster, 2003 and Özdeniz & Hançer, 2005).....	137
Table 33. The causing roots of roof defects in North Cyprus.....	142

LIST OF FIGURES

Figure 1. Distribution of population in North Cyprus (Devlet Planlama Örgütü, 2011).....	4
Figure 2. Comparison of effects of nine subsystems (Das & Chew, 2011).....	14
Figure 3. Roof forms (Davies & Jokiniemi, 2008).....	23
Figure 4. Flat reinforced concrete roof (Ching & Adams, 2001).....	28
Figure 5. Longitudinal section of a reinforced concrete beam (Ching & Adams, 2001).....	29
Figure 6. Metal flat roof (Ching & Adams, 2001).....	30
Figure 7. Open web steel joists (Ching & Adams, 2001).....	32
Figure 8. Standing roofs' spans (Özdemir, n.d.).....	33
Figure 9. Standing roof (Özdemir, n.d.).....	34
Figure 10. Standing roof truss with two hangers (Özdemir, n.d.).....	35
Figure 11. Standing roof truss with three hangers (Özdemir, n.d.).....	35
Figure 12. Standing roof truss with four hangers (Özdemir, n.d.).....	35
Figure 13. Hanging roof truss with one hanger (Özdemir, n.d.).....	36
Figure 14. Hanging roof truss with two hangers (Özdemir, n.d.).....	36
Figure 15. Hanging roof truss with three hangers (Özdemir, n.d.).....	36
Figure 16. Mono-pitched roof (Foster, 1994).....	37
Figure 17. Steel Rigid Frame (Ching & Adams, 2001).....	38
Figure 18. Position of thermal insulation in flat roofs (Ching & Adams, 2001).....	42
Figure 19. Cold roof: continuous insulation across ceiling (Emmitt & Gorse, 2005).....	43
Figure 20. Warm pitched roof (Emmitt & Gorse, 2005).....	43

Figure 21. Roof ventilation (Emmitt & Gorse, 2005).....	46
Figure 22. Roof ventilation (Emmitt & Gorse, 2005).....	46
Figure 23. Pitched roof ventilation (Emmitt & Gorse, 2005).....	47
Figure 24. Concrete roofing tiles and slates (Lyons, 2004).....	52
Figure 25. Built-up roofing system (Lyons, 2004).....	56
Figure 26. Typical single-ply roofing system (Lyons, 2004).....	57
Figure 27. Flat roof and its components (Chudley, 1989).....	62
Figure 28. Copper flat roof (Emmitt & Gorse, 2005).....	63
Figure 29. Conical roll (Emmitt & Gorse, 2005).....	65
Figure 30. Zinc batten rolls and drip (Emmitt & Gorse, 2005).....	65
Figure 31. Asphalt covered flat roof (Emmitt & Gorse, 2005).....	66
Figure 32. Asphalt skirting (Emmitt & Gorse, 2005).....	66
Figure 33. Wall insulation joined to roof insulation (Emmitt & Gorse, 2005).....	70
Figure 34. Copping stone (Emmitt & Gorse, 2005).....	71
Figure 35. Ventilation of a pitched roof (Emmitt & Gorse, 2005).....	72
Figure 36. Single lap tiles (Emmitt & Gorse, 2005).....	75
Figure 37. Pantile (Emmitt & Gorse, 2005).....	76
Figure 38. North Cyprus (URL 1).....	89
Figure 39. Construction in North Cyprus (URL 2).....	89
Figure 40. Construction in North Cyprus (URL 3).....	89
Figure 41. The percentage of flat and pitched roofs in some of the rural and urban parts of Nicosia district (Google earth, 2014d).....	90
Figure 42. The percentage of flat and pitched roofs in some of the rural and urban parts of Famagusta district (Google earth, 2014c).....	90

Figure 43. The percentage of flat and pitched roofs in some of the rural and urban parts of Kyrenia District (Google earth, 2014b).....	91
Figure 44. The percentage of flat and pitched roofs in some of the rural and urban parts of Iskele District (Google earth, 2014a).....	92
Figure 45. The percentage of application of different roof structures in North Cyprus.....	93
Figure 46. The level of satisfaction of the owners.....	99
Figure 47. The preferred material for roof structure according to the owners.....	100
Figure 48. Preferred roof forms according to the owners in TRNC.....	100
Figure 49. The level of satisfaction of the constructors.....	101
Figure 50. Preferred roof types according to the constructors.....	101
Figure 51. Popular roof types today.....	102
Figure 52. Standing timber roof construction in North Cyprus.....	106
Figure 53. Flat reinforced concrete roof construction in North Cyprus.....	107
Figure 54. Inclined and flat reinforced concrete roof construction in North Cyprus.....	108
Figure 55. Standing timber roof construction in North Cyprus	109
Figure 56. Flat reinforced concrete roof construction in North Cyprus.....	110
Figure 57. Flat reinforced concrete roof construction in North Cyprus	111
Figure 58. Standing timber roof construction in North Cyprus	112
Figure 59. Low sloped metal roof construction in North Cyprus.....	113
Figure 60. Metal truss construction in North Cyprus.....	114
Figure 61. Low sloped metal roof construction in North Cyprus.....	115
Figure 62. Standing timber roof construction in North Cyprus.....	116

Figure 63. Inclined and flat reinforced concrete roof construction in North Cyprus.....	117
Figure 64. Inclined reinforced concrete roof construction in North Cyprus.....	118
Figure 65. Pitched timber roof construction in North Cyprus.....	119
Figure 66. Pitched timber roof construction in North Cyprus.....	120
Figure 67. Roof defects according to the owners.....	121
Figure 68. Roof defects according to the constructors.....	122

Chapter 1

INTRODUCTION

1.1 Introduction

Design and construction defects are the reason of significant maintenance expenditures (Assaf et al., 1996). While defects have become accepted parts of the construction process, it is the main aim of designers and constructors to minimize them in order to enhance profits (Chong & Low, 2006). In this respect, obtaining knowledge related to the subject and defining what is meant by defect are the first steps toward prevention and remedies.

Various definitions are given by professionals for defect. This thesis uses the definition of Watt in 1999 as the base. “Defect is the term used to define a failing or shortcoming in the function, performance, statutory, or user requirements of a building, and might manifest itself within the structure, fabric, services or other facilities of the affected building” (Watt, 1999).

All building elements are susceptible to defect (Das & Chew, 2011). However, type of defect is directly affected by the function of that building member. Roofs are one of the major elements of the building envelope and are in direct contact with the surrounding environment. Lots of researchers have emphasized the importance of roof defects (Watt, 1999; Das & Chew, 2011; McCampbell, 1992; Perry, 2000; Ilozor et

al., 2004). In this respect, this thesis focuses on contemporary roof defects in North Cyprus in order to improve its current condition.

1.2 Problem Statement

Despite the fact that there exist a number of construction rules in North Cyprus (one of these rules is FASIL 96: Yollar ve Binalar Düzenleme Yasasi which was issued in 1959, the author's questionnaire survey during the first stages of collecting data together with the observations have illustrated that roof defects are still observed and the owners are not satisfied with the roofs' current conditions in North Cyprus. FASIL 96 devoted some parts into the roof construction (FASIL 96, 2012), however; these rules seem incapable of solving the problems. The reason can be improper design, material, inspection or maintenance. The objective of this study is to find the roots of this problem and suggesting solutions to solve them.

1.3 Aims and Objectives

By considering the mentioned problems and the costs that defects impose to both owners and constructors, this thesis aims to find the main reasons of roof problems in North Cyprus and tries to solve the problem by giving suggestions. In order to do so, this study tries to find answers for the following questions:

1. What is a defect and what causes defect in a building?
2. What are different categories of building defects?
3. What are different types of roofs from form, material, structure, construction detail and indoor air quality and insulation aspects?
4. Which roof types are constructed in North Cyprus?
5. What are the main roof defects according to the owners in North Cyprus?
6. What are the roof defects according to the constructors in North Cyprus?

7. According to the observations and design details what types of roof defects are detected in North Cyprus?
8. What are the suggestions to improve current conditions of roof construction and installation in North Cyprus?

By reviewing the existing literatures, the author tries to find answers for the first three questions. In this respect, the literature review section intends to find the origins of defects and the categorization of roof defects in the existing studies. The second chapter studies roofs from different aspects and categorizes them. The answer for the other questions are found in the third chapter of this thesis; while the last question is discussed in the discussion part.

1.4 Methodology of the Thesis

North Cyprus is divided into 5 districts which are Nicosia, Famagusta, Kyrenia, Güzelyurt and Iskele. These five districts are also divided into 12 sub-districts. According to the latest census in North Cyprus, which is done in 2011, the de-facto population is estimated to be 294,396 (Devlet Planlama Örgütü, 2011). The distribution of population among the districts of North Cyprus is demonstrated in the following figure. [Figure 1] Four Districts of North Cyprus (Nicosia, Famagusta, Kyrenia and İskele) are selected to collect the required data for this study. As it is demonstrated in Figure 1. these four districts together constitute approximately %90 of the population of North Cyprus which make them suitable cases to study roof construction in North Cyprus.

The required data for this thesis is gathered in two steps. The first step was to collect data related to the roof construction in North Cyprus. Similar to how roofs are studied

in the second chapter of this thesis, they are studied in five different categories which are: form, structure, material, indoor air quality and thermal insulation and construction details.

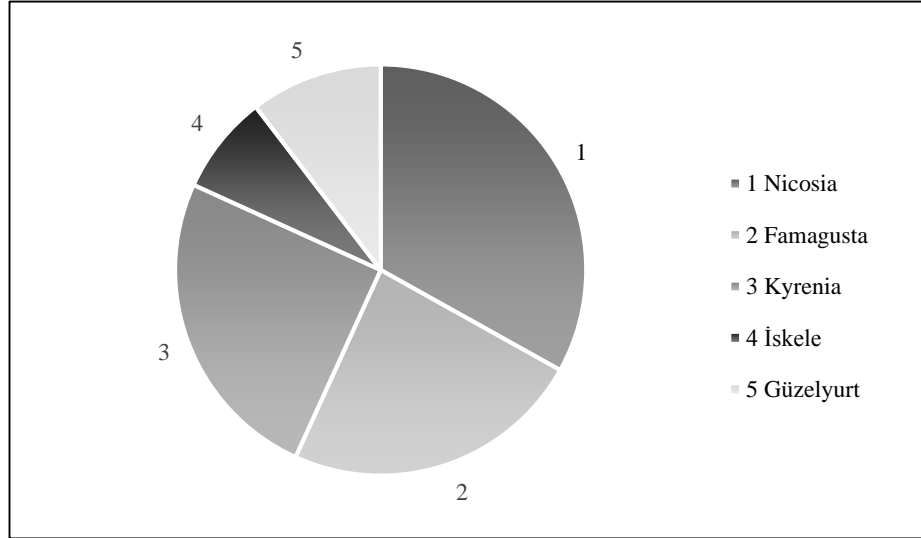

Figure 1. Distribution of population in North Cyprus (Devlet Planlama Örgütü, 2011)

In order to find roof forms in North Cyprus, Google earth maps are used and the percentage of pitched and flat roof are being counted in the urban and rural parts of Nicosia, Kyrenia, Famagusta and Iskele districts. The results are shown in the bar charts and are compared according to the percentage of application of flat and pitched roofs in these districts.

From 20 villages of the Nicosia district (Devlet Planlama Örgütü, 2009), 17 villages are selected together with its urban parts. From 18 villages of Famagusta district (Devlet Planlama Örgütü, 2009), 14 are selected. From 30 villages of Kyrenia (Devlet Planlama Örgütü, 2009), 18 are chosen; while from 30 villages of Iskele (Devlet Planlama Örgütü, 2009), 19 are counted.

In order to analyze roofs in North Cyprus according to their structure, material, indoor air quality and thermal insulation and construction details, 20 construction firms are chosen from these four districts. The number of construction firms in North Cyprus which are registered in Kıbrıs Türk İnşaat Mütahitleri Birliği is 488. %46 of these firms are located in Nicosia, %16 in Famagusta, %31 in Kyrenia and %3 in İskele (Kıbrıs Türk İnşaat Mütahitleri Birliği, 2012).

Some of these registered firms did not work at the time when the study was conducted and some did not respond to the questions. In this respect, 20 construction companies of North Cyprus are selected. 9 of these companies were located in Nicosia, 4 in Famagusta, 6 in Kyrenia and 1 in İskele.

The buildings which are built by these companies are analyzed and 15 projects which were the representatives of roof construction in North Cyprus are discussed in this thesis. These projects are analyzed according to the material, indoor air quality and thermal insulation and construction details. The results are demonstrated in tables. Furthermore, roof defects which originate from the designing stages in North Cyprus are analyzed in these selected projects. The constructors were also asked to rate the frequency of the application of roof structures in each district and the average is shown in a bar chart.

Furthermore, the architects, constructors and civil engineers of these firms are asked to fill close-ended questionnaires. Six questions are asked from the participants and their level of satisfaction, preferred roof type, common roof defects and popular roof systems in North Cyprus are asked from the constructors. Roof defects are asked by a multi choice question in the questionnaire; constructors were asked to choose

maximum 5 roof defects that they mostly observe in North Cyprus. The results are analyzed by Statistical Package for the Social Sciences (SPSS) version 21 and the results are illustrated in figures.

The second step of data collection process for this research was to analyze owners 5-6 years after occupation because it is the time when most of the building defects are observed (Chong & Low, 2006). The number of completed buildings in North Cyprus in 2009 is used as a base for calculating the sample size.

According to the municipality and district offices' statistics, 2064 private buildings with over ground story are constructed in Nicosia, Famagusta, Kyrenia and Iskele in 2009. Each district is divided into urban and rural regions. In Nicosia district, %10.22 of the completed buildings were constructed in urban regions and %19.08 were built in rural parts. In Famagusta district, %10.36 were constructed in urban and %4.99 in rural parts. In Kyrenia, %6.58 of buildings are located in urban and %36.24 in rural regions; while in Iskele %4.99 are in urban and %7.54 in rural areas. In addition to private constructions, some public buildings are built in 2009 in Northern Cyprus, however; for this study only private owners were accessible to analyze (Devlet Planlama Örgütü, 2009).

In order to study 2064 completed buildings in 2009, 326 cases should be selected (according to the sample size formula in Survey System, 2012). From Nicosia district, 34 owners are chosen from urban and 62 from rural areas. From Famagusta district, 36 respondents were selected from urban and 17 from rural regions. In Kyrenia district, 22 owners from urban and 117 from rural regions are analyzed. While in Iskele district, 17 respondents from urban and 21 from rural are studied.

Close-ended questionnaires are distributed among the selected owners. Level of satisfaction, the owners' preferences in choosing a roof system and roof defects which they have observed are asked from the respondents. The selected owners are asked to choose whether they are satisfied, neutr or dissatisfied with the buildings' roof system to find their level of satisfaction. The form of a roof which they prefer is asked by showing different roof forms to the owners and asking them to choose maximum three. Roof defects are chategorized according to the existing literature (Alibaba, 2003) and the respondents are asked to choose maximum 5 roof defects which they have observed in the building.

The quantitative data is analyzed by Statistical Package for the Social Sciences (SPSS) version 21 and the results are showed in figures so that it is possible to compare the results.

The last stage of collecting data was to observe contemporary roof defects. 42 different commonly occurring roof problems are observed in North Cyprus and they are studied by photographing and the results are shown in the tables.

1.5 Limitation of the Thesis

The diversity of roof systems all over the world has made it impossible for the author to study all of them within the limited time of this project. Hence, this research is limited to a specific case which is North Cyprus with its hot and humid climate. It is clear that the results are different in other regions and climates, thus; further comparative studies can be conducted to improve the quality of all roof types.

The main aim of this thesis is to analyze current roof systems and their defects in order to find suggestions to solve their problems, for this reason; historic roofs have become

out of the scope of this research. Only contemporary roof systems (roofs which are less than 20 years old) are studied.

Data gathering was limited by the accessible constructors. Although there are a lot of construction firms in North Cyprus, only 20 of them participated in the process of accessing the required data. Some of these companies did not work at the time when the data was collected and some refused to participate.

1.6 Organization of the Thesis

This thesis is divided into four chapters. In the introduction chapter, the problems, scope and limitation of this research are introduced and the literatures related to the subject are reviewed. The second chapter analyzes roofs from structural, indoor air quality and insulation, form, construction detail and material aspects. This type of classification is based on the definition of defect and roofs' function. The third chapter of this thesis is devoted to data analysis and findings; this chapter then continues with discussions and suggestions. Conclusion will be discussed in the last chapter of this thesis.

1.7 Literature Review

In the construction industry, words such as defect, error, failure and snag has been used interchangeably, with the same meaning of imperfection. However, ignoring the differences among these words can lead to the application of wrong strategies when trying to prevent those (Marcarulla et al., 2013). In the construction industry defect is more commonly used. There exist various categorizations for the reason of defects in a building. Chong and Low in 2006 have declared that details, climatic issues, dampness, the effect of users and loads, destruction, the quality of the applied materials and constructional problems are the main reasons of defects.

Defects in a building construction are often repeated several times as a result of lack of knowledge and carelessness. It is impossible to prevent all types of defects, however; they should be minimized in a building by proper design, automation and using software (Chong & Low, 2006). Defects have become accepted parts of building construction (Mills et al., 2009). Approximately %48 of the dwellings which have less than 10 years old, face severe problems. Today, the main aim of the constructors is to reach zero defect and improve profits and satisfaction of both employees and subcontractors (Leonard & Taggart, 2010 cited in Macarulla et al., 2013). The primary step to prevent defect is to gain knowledge. Various definitions are given by professionals. Some of them are mentioned in the following table. [Table 1]

All the definitions of defect are focusing on the performance and functions of a building element. This fact, resulted in the generation of various categorizations of defect in the building industry. Georgiou et al. in 1999 divided defects into major and minor ones according to their severity (Georgiou et al., 1999). While Sommerville and McCosh divide them into technical, omissions and aesthetic defects (Sommerville & McCosh, 2006).

Table 1. Definition of defect

Definition of Defects							
Atkinson, 1987	Knocke, 1992	CIB Working Commission W86, 1993	Watt, 1999	ISO 9000, 2005	Chew, 2005 cited in Marcarulla et al., 2013	Oxford English Dictionary	Webster Dictionary
‘‘A shortfall in performance which manifests itself once the building is operational’’	‘‘Physical manifestation of an error or omission’’	‘‘A situation where one or more elements do not perform it/their intended function(s)’’	‘‘A term used to define a failing or shortcoming in the function, performance, statutory or user requirements of a building, and might manifest itself within the structure, fabric, services or other facilities of the affected building’’	‘‘The non-fulfillment of a requirement related to an intended or specified use’’	‘‘Resulting from failures in function, performance, statutory, and user requirements’’	‘‘A shortcoming or falling short in the performance of a building element’’	‘‘Lack of something necessary for completeness, shortcoming’’

Seeley in 1987 claimed that %58 of defects are caused as a result of poor design, %35 because of installation and operational problems, %12 materials and %11 ignoring user needs (Seeley, 1987 cited in Chong & Low, 2006). Anderson, when studying vapor infiltration, concluded that the causing roots of defects can be divided into workmanship, material and design (Anderson, 1999).

Chong and Low in 2006 have discussed the causing reasons of which the defects are originated. The main reasons are design, workmanship, materials and maintenance. Auchterlounie focuses on the construction strategies, poor workmanship, poor material and analysis, lack of proper drainage system, poor design and installation when tries to categorize the roots of defects (Auchterlounie, 2009). Georgiou recognizes two main causes for defect: defects due to construction process and due to poor maintenance (Georgou, 2010).

BRE and Richardson in 1991, have mentioned climatic issues, environmental circumstances, the effect of land, lack of proper details, constructional changes, installing technique, manufacturing, preservation, and in-situ working situations, as the reason of building defects. While Richardson has another categorization and believes that building problems are caused by improper design and construction and sometimes by external factors (Richardson, 1991).

Assaf et al. have categorized roots of building defects in 1996, the results have demonstrated that constructional details, architectural details, the effect of details on maintenance, partialness and sufficiency, errors as a result of consultant company direction, problems as a result of poor drawings, errors because of contractor directions and problems because of materials are the reasons. Olubodum & Mole have mentioned

aging and vandalism as some of the roots of defects. Their research then continues by introducing other reasons such as design, construction, and the changing standards (Olubodum & Mole, 1999).

Andi and Minat in 2003 have focused on the defects which are caused during the design process. Lack of knowledge and information together with the effect of organizational factors have caused these defects (Andi & Minat, 2003 cited in Chong & Low, 2006).

Ahzahar et al. have discussed that errors are caused during the design, manufacturing, and installation process. Also materials can be the reason of problems. One the mentioned reasons or a combination of them can cause defects (Ahzahar et al., 2011).

All building element, services and members which help to use them and together construct a building are susceptible to defect (Das & Chew, 2011). Professionals have studied building elements in various categories. Das and Chew have generally divided building elements into two systems: Civil-Architectural system and Mechanical-Electrical systems. The first system has basement, façade, wet area and roof as sub systems, while sanitary and plumb, HVAC, elevator, electrical and fire protection are subsystems of the Mechanical-Electrical systems (Das & Chew, 2011).

Abdul-Rahman in 2014 has another type of categorization of building elements. He mentioned “foundation and floor structure, external walls, roof, internal walls and floors, above ground service, below ground drainage and external works, wall and floor finishes, damp proof course, door and window fixing, sanitary installation and piping work” as the main building elements (Abdul-Rahman, 2014).

Roofs are the major elements of the building envelope. The major function of a roof is to cover interior spaces. All roof types have same functions of providing ‘strength and stability, weather resistance, thermal insulation, fire resistance and sound insulation’ (Foster, 1994). Roofs are mentioned as one of the important members of civil-architectural systems and for this reason they are also susceptible to defects.

A research on 12,000 defects was done by Institut Technique du Bâtiment et des Travaux Publics in 1982 has illustrated that roofs are the most defective building elements. Another research in Australia concluded that roofs are the second critical building elements, because they are influenced by temperature changes, solar radiation, wind, rain and snow. In addition, any kind of defect in roofs can lead to severe problems and even its failure (Ilozor et al., 2004).

BRE has studied 955 low-rise buildings in 1988 and concluded that roofs are the second defective building members (summarized in BRE, 1988 cited in Watt, 1999). However, the difference between the climates of the regions in which these studies are conducted with the climate of North Cyprus, may cause different results. For this reason, the most beneficial results are the ones which are concluded from the research done by Das and Chew in Singapore.

Das and Chew have studied defects in different building elements. Their criticality, the frequency of occurrence, economic impact, effect on the performance of building system and their impact on human health. The figure shows that roof defects are not often critical ones, however; they are frequently occurring and have great economic impact (after basement/façade and HVAC). Additionally, they are the most effective

defects on the human health among subsystems of civil-architectural system (Das & Chew, 2011). [Figure 2]

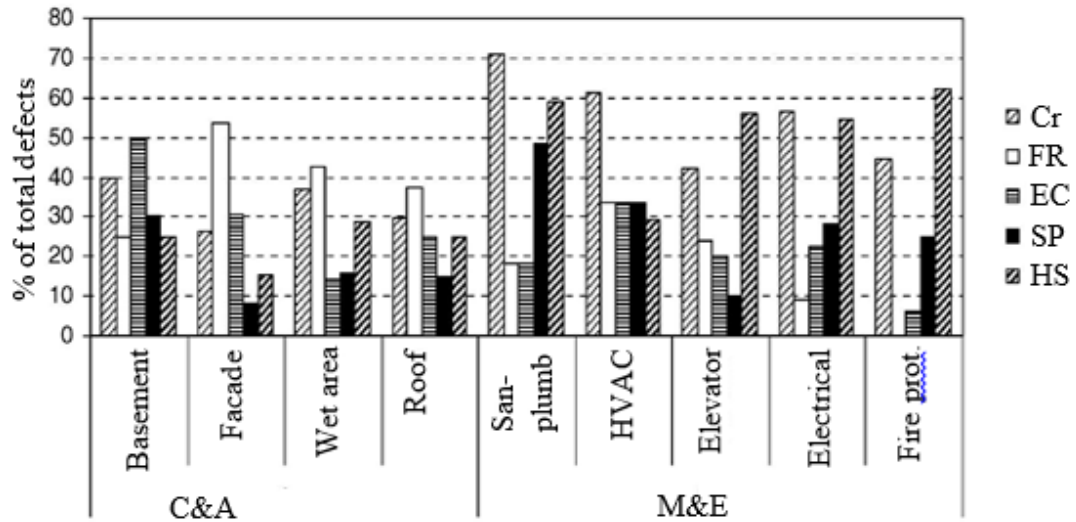

Cr= Critical defects, FR= Frequent defects, EC= Defects with significant economic impact, SP= Defects with significant system performance impact, HS= Defects with significant health-safety-comfort impact.

Figure 2. Comparison of effects of nine subsystems (Das & Chew, 2011)

Various professionals have attempted to categorize and study roof defects. Bell and Parker have studied a store and divided roof problems into three main categories: design, construction and maintenance. They claimed that ponded water, buckling beam-column connections, poor quality welds and poor maintenance have caused defects in the case (Bell & Parker, 1987). Small and Swanson have analyzed another roof and found out that the failure of roof occurred as a result of ignoring what is designed, constructing weaker than what is designed, and failure of the weakest parts (Small & Swanson, 2006).

Coffelt and Hendrickson have studied leakage as one of the most frequently occurring roof problems and its economic impact (Coffelt & Hendrickson, 2012). Walter et al.

studied waterproofing systems in roofs and specifically focused on bituminous, the causing reasons of its defects and methods to repair it. They summarized the reasons of defects as: “design error, application error, external mechanical accidental actions, environmental actions, lack of maintenance, changes in the initially predicted in-service conditions” (Walter et al., 2005). Morcous and Rivard have studied defects for the three members of low-slope roof independently (membrane, flashing and insulation). They concluded that “blisters, debris and vegetation, improper equipment support, holes, flashing, patch, ponding, ridges, slippage, splits, surface deterioration, drains and scuppers, embedded metal edge, flashed penetration, metal cap, pitch pans, wet insulation” are the main errors of low-slope roof types (Morcous & Rivard, 2006). Jordan has focused on the roofs’ drainage systems and claimed that most of the collapses during heavy rainfalls are originated from the drainage system. Finally, he suggested methods for proper drainage design (Jordan, 2005). Another research, related to the drainage system was done by Verhulst et al. They concluded that poor design and maintenance result in ponding which cause deflection and collapse (Verhulst et al., 2009).

Hinks and Cook have written a book related to building defects. This book studies felted flat roofs, mastic asphalt flat roofs, metal-clad flat roofs and pitched roofs separately. [Table 2] Chong and Low in 2006 found out that leakage, cracks, water proofing, delamination, stain and poor thermal insulation are the main roof errors (Chong & Low, 2006). While another research which is done by Chong and Low in 2005 had generally categorized the root of roof defects into: design, workmanship, material, maintenance and lack of protection (Chong & Low, 2005).

Table 2. Roof defects (Hinks & Cook, 1997)

Felted flat roofs	Mastic asphalt flat roofs	Metal-clad flat roofs	Pitched roofs
<ul style="list-style-type: none"> • Cracking • Small blisters • Large blisters • Ridging and cockles • Lap or joint failure • Ponding • General deterioration • Loss of chippings • Dents and rips • Sticky or semi-liquid surface • Water ingress • Splitting parallel to metal eaves trim 	<ul style="list-style-type: none"> • Crazing • surface cracks • Cracking • Blisters • Ridging or cockling • Ponding • General damage • Chemical damage • Loss of chippings • Discolored solar treatment • Water ingress • High temperature embrittlement • Low temperature embrittlement 	<p>Lead:</p> <ul style="list-style-type: none"> • Splits and cracks • Dents and cuts • Edges lifting • Surface marking • Loss of metal • Sugaring to underside of metal • White streaks • Movement of lead <p>Copper:</p> <ul style="list-style-type: none"> • Patina or verdigris • Corrosion of fixings • External corrosion from internal sources • Cracking around seams and rolls • Water ingress • Dents and cuts • Edge lifting <p>Zinc:</p> <ul style="list-style-type: none"> • Surface corrosion and pitting • Internal surface corrosion • Water ingress • Dents and cuts • Edges lifting 	<ul style="list-style-type: none"> • Roof units loose and/or slipped • Sagging of roof • Roof spread causing cracking and outward movement of walls • Deterioration of timber • Lamination and Spalling of clay tiles • Lamination of natural slates • Deterioration of cedar shingles

Ilozor et al. have studied residential house defects in Australia and one part of their study focuses on roofs. They found out that the reason of all roof faults are improper material, slope, guttering and in some cases external factors (Ilozor et al., 2004). Forcada et al. have studied housing defects in Spain and concluded that the roof errors often occur as a result of poor installation and drainage. After these two, the missing parts of roofs affects surface appearance and causes problems (Forcada et al., 2014). Furthermore, Abdul-Rahman et al. have studied defects as a whole in Malaysia and in

one part of their article which is related to roof defects they have claimed that “water staining, mold growth, fungal decay, deterioration of covering, deformation or displacement of roof” are the major roof problems (Abdul-Rahman, 2014).

In this respect, the existing literatures related to roof defects can be reviewed in three categories. The first type are the ones which select one or more specific case(s) and study the roots of defect according to the authors’ experiments (Bell & Parker, 1987; Gurfinkel, 1988; Estenssoro, 1989; Perry, 2000; Small & Swanson, 2006; Bolduc, 2011; Pinto et al., 2011).

The second type of literatures focus on one type of roof defect; trying to give suggestions in order to solve the problem (Bailey & Bradford, 2005; Coffelt & Hendrickson, 2012; Walter et al., 2005; Morcoux & Rivard, 2006; Jordan, 2005; Verhulst et al., 2009). The last type of studies analyze all building defects and mention roofs as part of these defective building components (Hinks & Cook, 1997; Ilozor et al., 2004; Chong & Low, 2005; Chong & Low, 2006; Abdul-Rahman et al., 2014; Forcada et al., 2014).

None of the existing literatures have a general view to all types of roof defects both during the construction process and 5-6 years after handover and this gap currently exists among existing literatures. Most of the building defects are recognized 5-6 years after occupation when it is difficult to access the building in order to gather information. These types of defects are not often reported unless they are severe enough to be reported to the authorities. However they are the reason of significant costs and affect human health. In addition, no research have studied roof defects in

North Cyprus which has hot and humid climate. For these reasons contemporary roof defects have become the subject of this thesis.

Chapter 2

EVALUATION AND CATEGORIZATION OF ROOFS

2.1 Introduction

The important role of roofs can be fully comprehend when the elementary function of a building is considered. This role comes to our language when we say ‘‘under/one/roof’’ which is not always the physical form of a building. The meaning of a building is inseparable of the word protection, which is totally met by a roof (Shunck et al., 2003).

Heidegger declares the relation between verbs: to build, to live and to be. ‘‘ He traces the Middle High German etymological roots of these verbs and arrives at words meaning to be satisfied and protection against pursuit’’. And he finally arrives to some meanings like free and freedom. This illustrates that building, house and roof are some needs of a human being, because separating interior spaces from exterior ones is a primary human need which is met by a roof. In fact, roof identifies a space by separating it from other external spaces and everything which is situated under it is demarcated (Shunck et al., 2003).

Human being began to construct roofs to cover their individual spaces and to determine their status and that was how the definition of beauty was born. In fact roofs are symbols of the main role of a building. We live in an era when architecture requires a definite change and roofs are not exceptions (Shunck et al., 2003).

The first step toward change is gaining knowledge, for this reason; roof types are studied from different aspects; thus, it becomes possible to categorize them and to analyze their defects.

2.2 Roof Forms

Roofs are multi-task building elements. Each of the tasks that a roof should do as a member of the building envelope affects its form. The major task of a roof is to protect other members of the construction and to have unity with the components of the building envelope (Schunck et al., 2003).

Shunck et al. in 2003 have discussed that three major parameters should be considered when choosing type of a roof: ‘use, construction and form’. Besides, landscape becomes also important because roofs should form a unity with the landscape in which they are located. In this section the main aim is to find which factors affect form of a roof and to discuss their main forms.

The simplest roof forms are mono-pitched ones. Among mono-pitched roofs, the professionals are almost certain that the first type of roofs were lean-to ones. They are still popular roof forms, however; often used as an extension to the main building. Lean-to roofs have a single pitch and are connected to a wall from one side. This form gives the quality of easily draining rainwater from the building (Jupp, 2002).

Later, when mankind began to proceed from lean-to roofs, into roofs which are supported with struts and pillars, they started to face problems related to draining rainwater and soon they understood that slopes are essential to construct a roof. In this

respect, duo-pitched roofs were constructed which were more advanced compared to the lean-to ones (Jupp, 2002).

With respect to the culture of each region, various materials and roof components have caused different types of roofs and related skills. The diversity of roof systems can fulfill different functions (Flickinger, 2001). However, in this chapter only roof systems which are common in North Cyprus are discussed.

Ching and Adams have studied roofs in three forms: flat roofs, low-pitched roofs and high-pitched ones. The main advantage of flat roofs is that they can horizontally cover all buildings, regardless to the form and plan. It should be mentioned that the roofing material for a flat roof should be continuous (Ching & Adams, 2001).

Pitched roofs can be divided into two wide categories according to the angle of slope. The ones which have an inclination less than 3:12 are called low-pitched roofs, while an inclination more than that (4:12 to 12:12) is named medium to high slope. It should be mentioned that the angle of a slope influences roofing materials, type of eaves and the resistance of the roof against wind loads. For example for low-pitched roofs it is better to apply continuous roofing materials (Ching & Adams, 2001).

Ching and Adams have also divided pitched roofs into gable roofs, hipped roofs and gambrel ones according to their appearance. Gable roofs are the ones which have two downward sloped plates from a central ridge and form gables. Another type of pitched roofs are hipped ones. ‘‘Hipped roofs have sloping ends and sides meeting at an inclined projecting angle (Ching & Adams, 2001)’’. They have a genteel form which are believed to be constructed as an imitation of the mansion house (Schunk et al.,

2003). Gambrel roofs are divided on each side into a shallower slope above a steeper one (Ching & Adams, 2001).

Curved form roofs are created in order to solve some constructional problems. In many cases domes were used for religious buildings. While these forms were first chosen to solve structural problems, they soon became popular because dome forms attracted people and could be used for especial functions. The relation between form and importance of a building was then rejected during Post-Modernism period (Schunk et al., 2003).

Another categorization of the form of a roof is done by Alibaba in 2003. He has divided roof forms into: flat, pent, gable, hipped, butterfly, sawtooth, tower, mansard, folded slab, barrel vault, mushroom, geodesic domes, tensile, inflated, membrane and supported roofs (Alibaba, 2003).

Dictionary of architecture and building construction has also categorized various roof forms. These forms are demonstrated in the following figure. [Figure 3]

In recent years, with the development of aircraft and automotive industries, the new trend of creating fluid transition between different elements of the building envelope have become popular (Schunk et al., 2003). The new techniques have created various innovative roof forms which are rarely used in North Cyprus. Therefore, in this thesis they are not analyzed. The appearance of a roof is affected by the applied materials and textures, the angle of slope and the way different roof components are arranged (Schunk et al., 2003). All these factors are studied in the following paragraphs.

					
Pent roof	Duo pitched	Pavilion roof	Hipped roof	Gabled roof	Gabled mansard roof
					
Jerkinhead roof	Hipped mansard roof	Gambrel roof	Knee roof	Hipped knee roof	Half hip and gable roof
					
L roof	Heel gable roof	Crossform roof	Monitor roof	Split-level roof	Split-level roof
					
Catslide roof	Skirt roof	Butterfly roof	M roof	Sawtooth roof	Lean-to roof

Figure 3. Roof forms (Davies & Jokiniemi, 2008)

Edges of a roof perform different tasks and they should be designed accordingly. For example, in the case of gable roof, ridge should be designed in a way that rainwater cannot penetrate from the junction between the slopes. Besides, ridge should prevent from the movement of the related pitched plates (Schunk et al., 2003).

In case of mono-pitched roof, ridge should also resist the roof's movements and verges should have the ability to move independently regardless to the external walls' movements. They should also protect the building envelope. Eaves do almost similar tasks additionally they should drain rainwater and provide ventilation when required (Schunk et al., 2003).

Arises are roof components which accommodate movements of the adjoining parts. ‘‘ridge of a gable roof, hips, valleys, troughs, cranks and steps’’ are various members of the roofs' arises. In addition to arises, openings which are implemented to provide fresh air and light, can affect the form of a roof (Schunk et al., 2003).

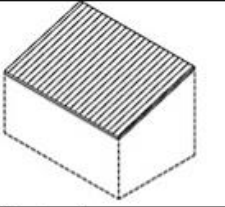
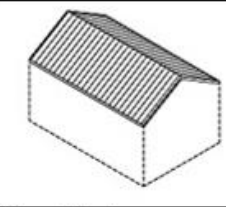
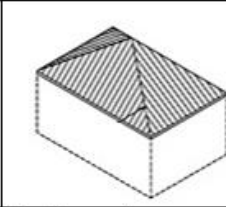
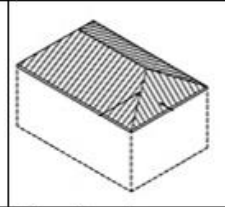
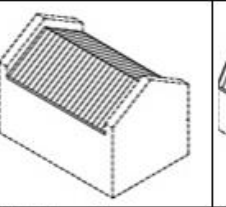
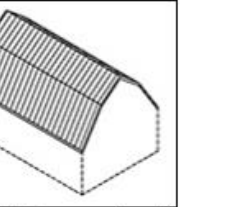
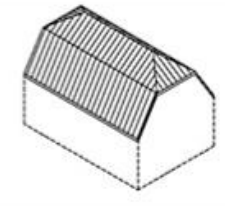
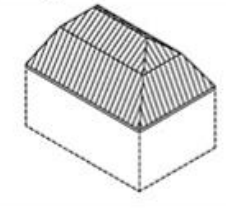
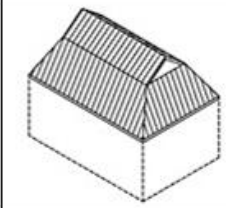
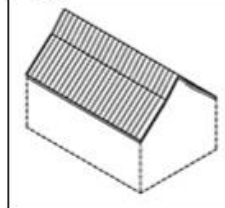
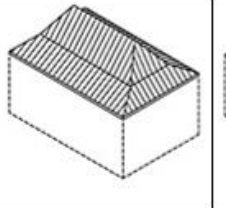
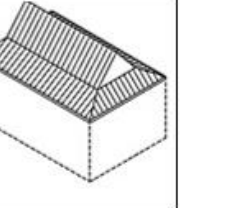
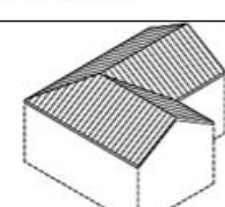
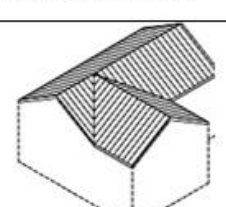
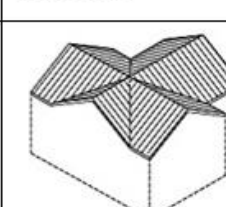
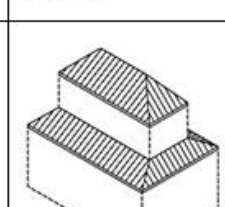
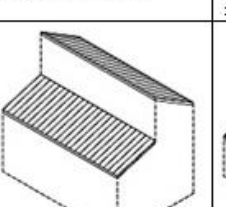
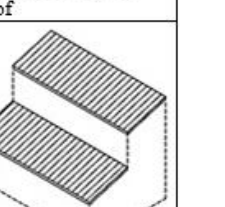
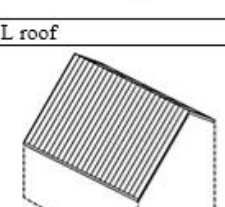
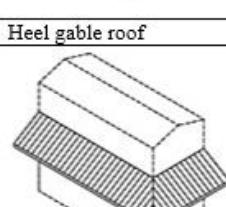
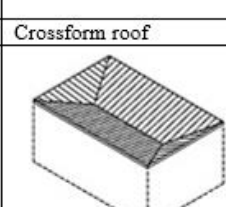
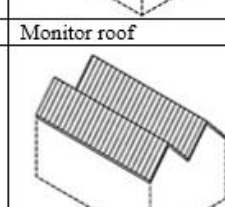
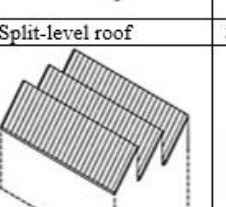
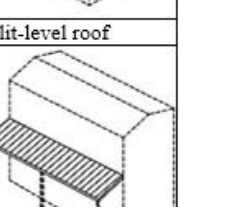
Penetrations are similar to the openings in a plane roof. When penetrations are large, drain channels are needed and ventilating these roofs becomes highly complicated (Schunk et al., 2003). [Table 3, 4]

Table 3. Roof components (Schunk et al., 2003)

Surface	
Edges	Ridge, verge, eaves
Arises	Ridge, ridge of gable roof, hip, valley, trough, crank, step
Penetrations Openings	Chimney etc., window, dormer window
Junctions	wall

Table 4. Edges of a roof (Schunk et al., 2003)

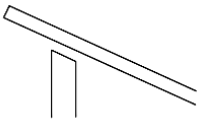
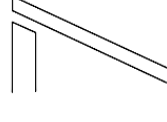
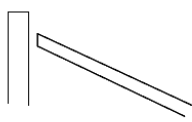
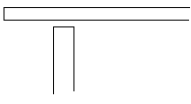
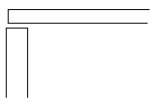
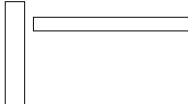
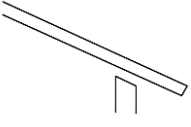
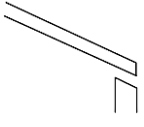
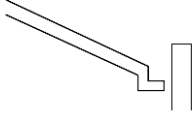
	Roof overhang	Flush	Wall parapet
Ridge			
Verge			
Eaves			

2.2.1 Materials and Forms

Form of a roof has great impact on the materials which professionals choose. If all materials are used for all forms of roofs, sense of the material is ignored. Especially for pitched roofs, materials directly affects form and the appearance of a roof. Materials which are suitable for low-pitched roofs can also be used for steeper ones, however; the reverse is not always true (Schunk et al., 2003).

Two types of relationships can be between a roof and building: unity or separation. Traditional buildings had unity when applying materials such as stone, brick and years later, concrete and metal. These types of buildings have a homogenous envelope. The only problem is that the effect of climatic loads are higher on roofs compared to the other members of the building envelope and using the same material may increase the costs or be inadequate.

In response to the discussed problem, the second method of separation was created, when roof behaves like a canopy over external walls. Even in buildings which have an overlap between walls and roofs, the second method can be used (Schunk et al., 2003).

2.2.2 Roof Form and Providing Energy

When roofs are utilized to provide energy, their appearance would completely change. The glasses which are used as collectors are in total contrast with roofing materials. Form of panels are almost impossible to be changed and roofs cannot be constructed in form of panels. The most appropriate way to create harmony and unity between these two is to cover the whole roof with panels. It is obvious that the required amount of energy should be measured in this case.

Plate of a roof can be covered with vegetation which has positive impact on the climate in which the building is situated. In addition, vegetation reduces the amount of energy which is essential for heating and cooling interior spaces. Planted roofs need especial details for different building members which at the same time affect form of the roof (Schunk et al., 2003).

2.3 Roof Structures

In most of the buildings, roof is used to protect the spaces beneath it from adverse weather conditions. In multistory buildings, shorter spans are used which means that roofs are constructed similar to the floors. However, in small houses, long spans necessitate flat roof with timber and reinforced concrete or pitched roof with either timber or steel. In these types of buildings, roofs become important building components (Foster, 1994).

Roofs can be divided into different categories from structural point of view. Different form of planes of the outer layer, size of spans and structural principles can create various types of structures for roof systems (Foster, 1994).

Size of spans directly affects the type of roof and the structure which is chosen. Foster categorizes spans as following: less than 7.50 m short span, 7.60-24.40 m medium span and over 24.40 m long span. When structure is considered, short spans are more economical and have better performance, however; in some cases the function of a building does not allow the designer to locate internal supports. Thus, designer has to find the shortest span which is possible according to the clear floor area which is required. It should be noted that 3-dimensional structures are not economical choices for short spans (Foster, 1994).

The form of a roof's structure can be categorized as two or three dimensional ones. The former, has only two dimensions (depth and length), all forces and loads are resolved within these two dimensions, while the later has three dimensions (length, depth and breadth) (Foster, 1994).

2.3.1 Flat Roofs

The roofs which have horizontal plane or an inclination less than 10 degrees are called flat roofs, while pitched roofs have an inclination higher than 10 degrees. Climate often determines which one to choose, however; in moderate climates architectural aspects become more important (Foster, 1994).

Today, various flat roof structures are applied by the constructors all over the world (for example single flat roof with timber, double flat roof with timber, reinforced concrete flat roof, precast concrete flat roof, flat metal roof, open web steel joists, etc.);

however, in this section, only the ones which are more common in North Cyprus are discussed.

- **Reinforced concrete flat roofs**

Reinforced slabs are in shape of plates which can be reinforced in one or two directions. In order to calculate the distances between bars and their sizes, related building codes should be used. Beams in a reinforced concrete roof should be designed in such a way that they can resist longitudinal loads. Part of the reinforced concrete slabs always acts with beams (Ching & Adams, 2001).

Steel bars in reinforced concrete beams extend continuously down the columns to guarantee the strength of the structure. In order to minimize bending in the structure, continuity between all structural members is required. The details of a concrete flat slab is shown in the following figures (Ching & Adams, 2001). [Figure 4, 5]

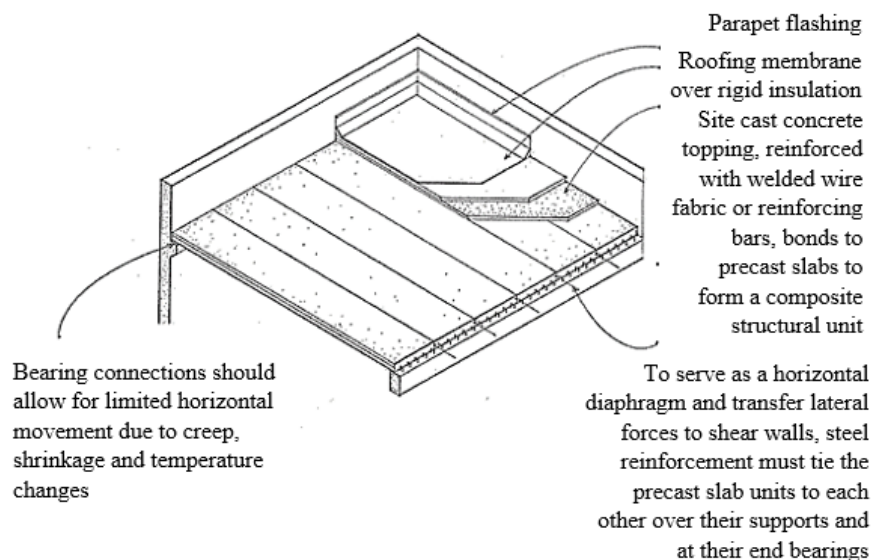

Figure 4. Flat reinforced concrete roof (Ching & Adams, 2001)

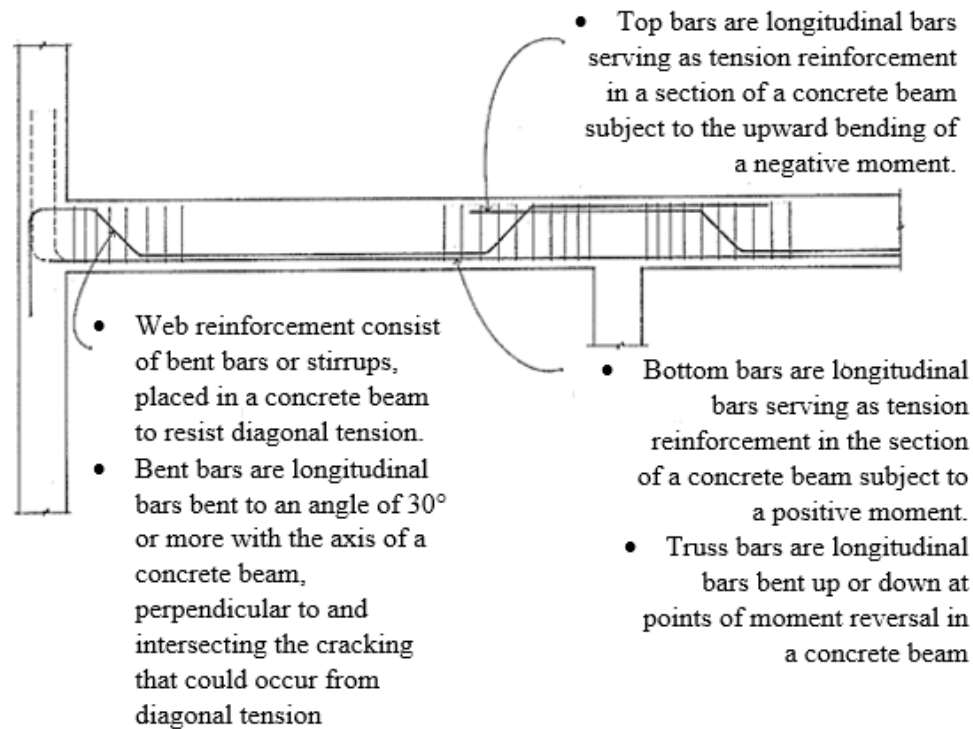

Figure 5. Longitudinal section of a reinforced concrete beam
(Ching & Adams, 2001)

- **Precast concrete flat roofs**

Slabs, beams and tees are the members of a precast roof. These roof components are constructed in the form of one way units which can be supported in various ways. Site-cast concrete, precast concrete, masonry techniques or steel can be used to support the structure. The major advantage of this structure is that it is pre-stressed, thus; less thickness is required. This fact makes the structure lighter and more suitable for longer spans (Ching & Adams, 2001).

In order to manufacture the structure, members are casted and cured in the factories and transported to the site. Structural components are connected with rigid joints and cranes are utilized to place them. This method enhances the final quality because factory production is precise and fast. In addition, less on-site construction duration

and higher strength are other advantages of precast concrete structures. The major disadvantage of this type of structure is that, it limits the form of buildings because forms should be standardized to cut down the costs in factory production (Ching & Adams, 2001).

- **Metal flat roofs**

Steel skeletons are constructed with beams, columns and girders. These types of structures can be constructed in different heights, from a single-story buildings to skyscrapers. Steel is difficult to be cut and shaped in-site, thus; the structural components are prepared in the factories and then transported to the site. Shaping structure in factories reduces the construction duration and increases quality. (Ching & Adams, 2001).

Type of connectors which are used for steel structures is one of the primary issues to discuss. Different connectors or combination of some of them can be applied. The type of connector is commonly selected according to the required strength, rigidity and the cost of connection. Even the appearance can be effective in cases when the connector is exposed (Ching & Adams, 2001). [Figure 6]

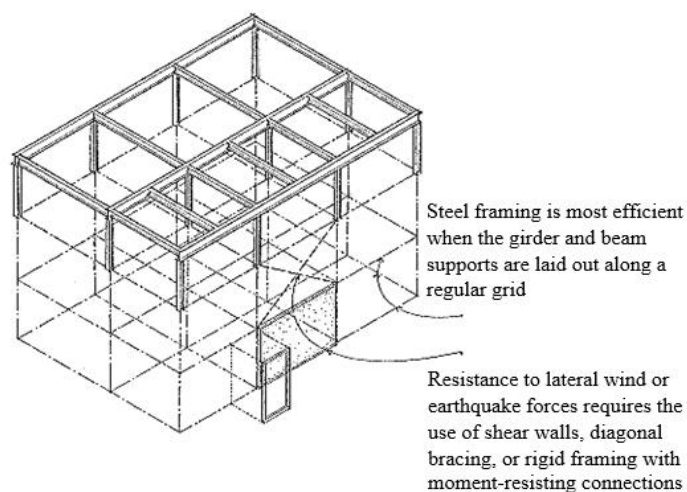
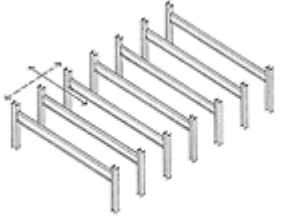
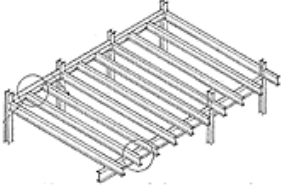



Figure 6. Metal flat roof (Ching & Adams, 2001)

Flat metal roofs can be categorized according to their beam systems. The following table demonstrates different types of flat metal roofs [Table 5].

Table 5. Different types of flat metal roofs (Ching & Adams, 2001)

<p>One way beam system</p>	<p>Each pair of columns support a beam or a girder. They are the most appropriate choices for narrow plans because they can provide narrow and long spaces without any columns. It is obvious that lateral load carrying is required in this case especially in the direction of shorter spans.</p>	
<p>Two way beam system</p>	<p>—</p>	
<p>Triple beam system</p>	<p>When large column-free interior spaces are required, girders and trusses are used to protect the primary and secondary beams.</p>	

- **Open web steel joists**

These types of structures have trussed webs and are produced in factories. Their main characteristic is that they are light. The trussed web can be manufactured in various forms and the K-series has the minimum strength compared to the LH and DLH-series. The latter two types are suitable for longer spans (Ching & Adams, 2001). [Figure 7]

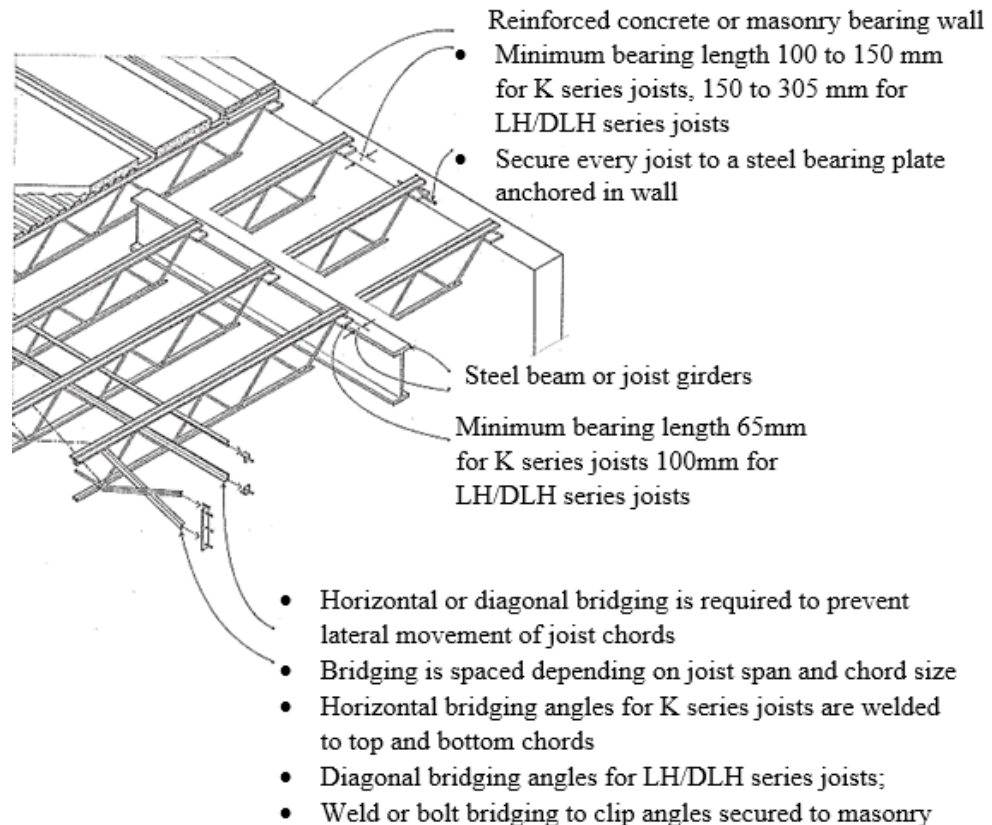

Figure 7. Open web steel joists (Ching & Adams, 2001)

2.3.2 Pitched Roofs

In the climates where lots of rainfalls are observed, pitched roofs with higher inclination are the best choices; while in regions with high amount of snow falls, less inclination is desirable (less than 35-40 degrees). Snow on roofs performs as a natural thermal insulation in winter and thaw water falls down easily (Foster, 1994).

The degree of slope is also determined by the type of covering which is chosen. There are two types of coverings: unite and membrane materials. The former, needs higher inclination as the small space between tiles increases the potential of water penetration. The degree of slope depends on the size and form of the units. However, membrane materials, can be applied for both flat roofs and pitched ones (Foster, 1994).

Similar to flat roofs, the pitched ones are also constructed with different structures. Some of these structures are: wood rafters with sheathing, mono-pitched roof structure, lean-to roof structure, couple roof structure, closed-couple roof structure, collar roof in timber, timber beams with purlin and decking, steel rigid frame, truss, etc. Among all these pitched roof structure types, only the ones which are common in North Cyprus are studied in detail. Two types of common timber roof structures are standing and hanging roofs which are discussed here. Later the structures of mono-pitched, lean-to and couple roofs are studied.

- **Standing roofs**

The simplest type of pitched-roofs with slopes on both sides are called ridged roofs. Although couple roofs are simple, they are not always economical to construct (Foster, 1994).

Standing roof is a type of roof with all elements over bearing walls, joists, or a reinforced concrete slab. When roof is situated over bearing walls or joists, the effective span cannot exceed 4 m. The following figures demonstrate this type of structure (Özdemir, n.d.). [Figure 8, 9]

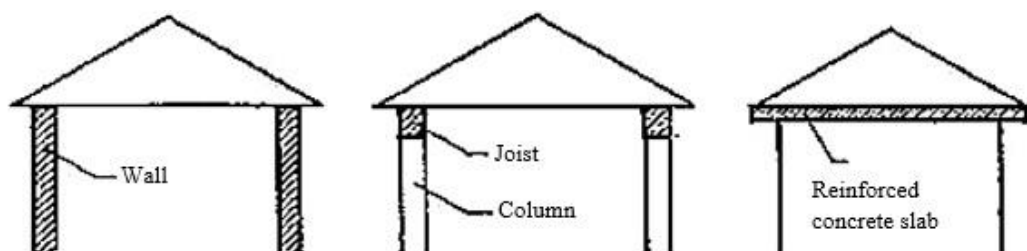

Figure 8. Standing roofs' spans (Özdemir, n.d.)

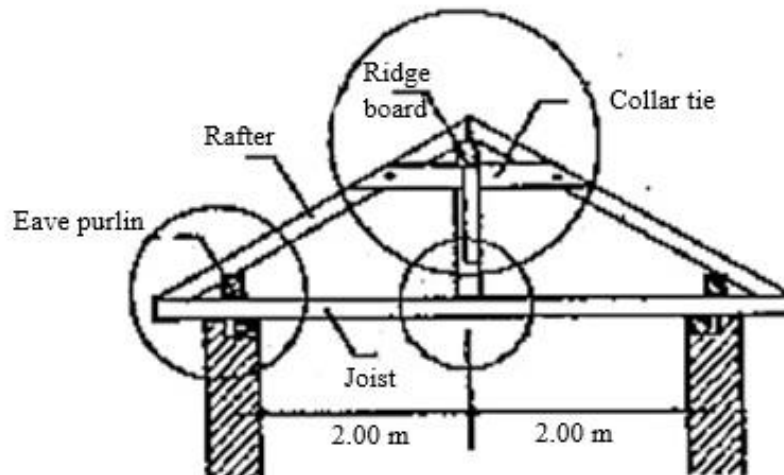

Figure 9. Standing roof (Özdemir, n.d.)

Construction steps:

- Bearing plates are placed over the bearing walls or slab
- Joists are located over plates (if there is no slab)
- Eave purlins are situated at the edges; while hangers are between purlins and intermediate purlins and ridge board are over hangers
- Struts, collar ties, and wind bracing are supporting roof and prevent from lateral movements
- Rafters are nailed perpendicular to the purlins
- Roof sheathing and roof covering are placed over the rafters

When the closest distance between purlin and ridge does not exceed 2 m; instead of ridge board rafters are tongue and grooved together.

Joists, struts, purlins, ties and rafters are making a triangular shape in a same plane; for this reason, this roof is also called a standing truss. The distance between trusses should be 2 to 2.50 m. Simple forms of standing trusses are shown in the following figures (Özdemir, n.d.). [Figure 10, 11, 12]

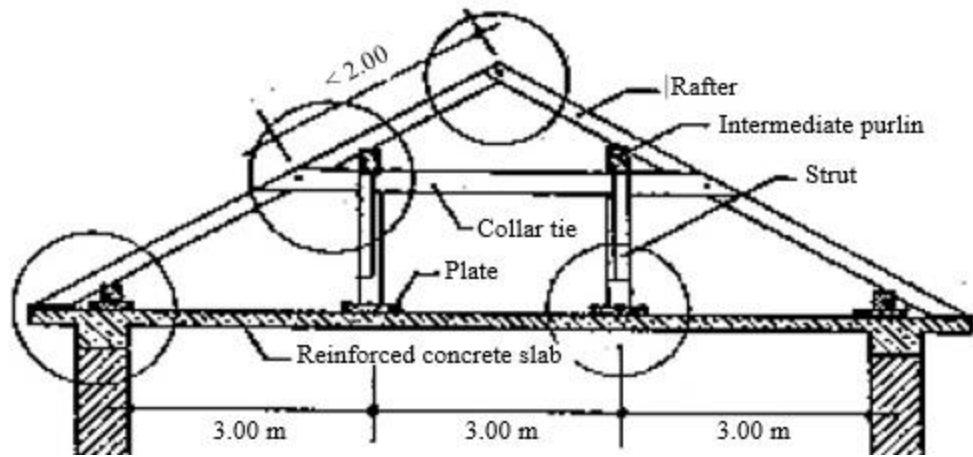

Figure 10. Free standing roof truss with two hangers (Özdemir, n.d.)

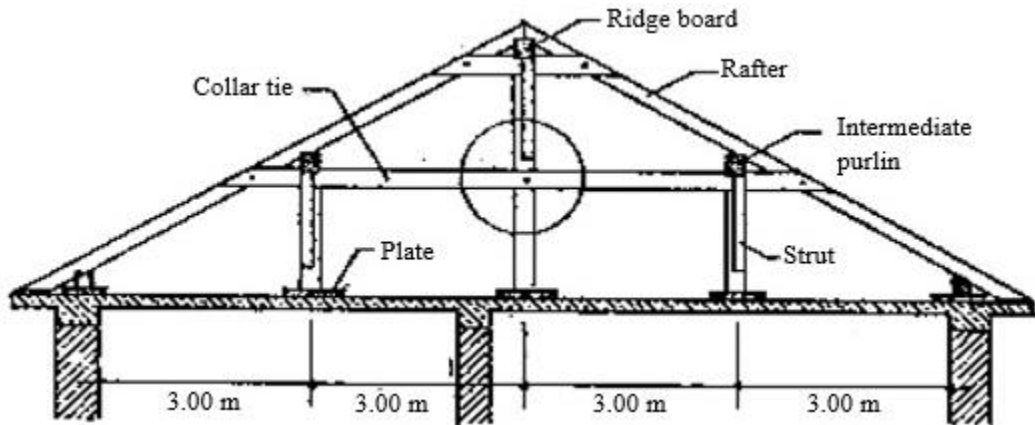

Figure 11. Free standing roof truss with three hangers (Özdemir, n.d.)

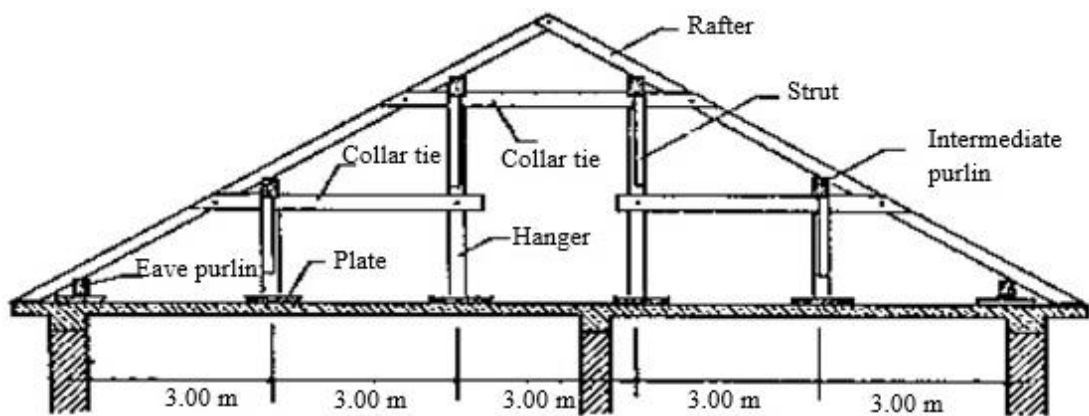

Figure 12. Free standing roof truss with four hangers (Özdemir, n.d.)

- **Hanging roofs**

When the distance between interior or exterior wall axes exceed 4 m, hanging roofs are often applied. In this case, the roof is supported by trusses. The elements of a hanging roof are joists, tie beams (bottom chord), hanger, main rafters, common rafters and supports (top chord). Joists and hangers are in tension; while rafters and supports are in compression (Özdemir, n.d.). [Figure 13, 14, 15]

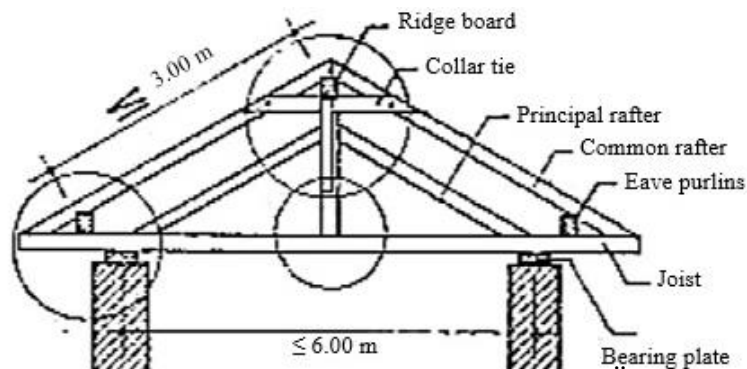

Figure 13. Hanging roof truss with one hanger (Özdemir, n.d.)

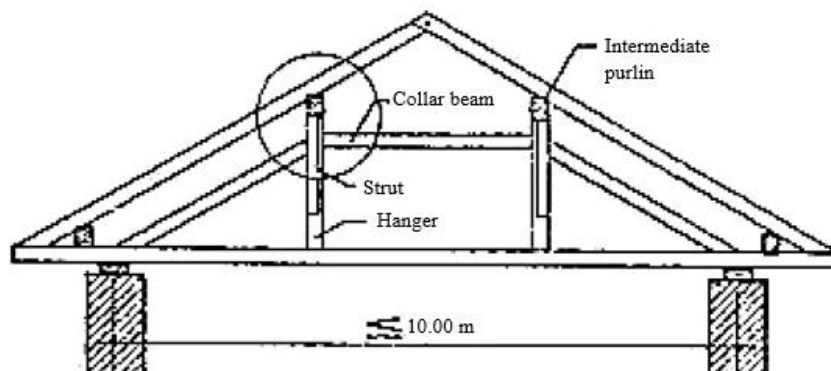

Figure 14. Hanging roof truss with two hangers (Özdemir, n.d.)

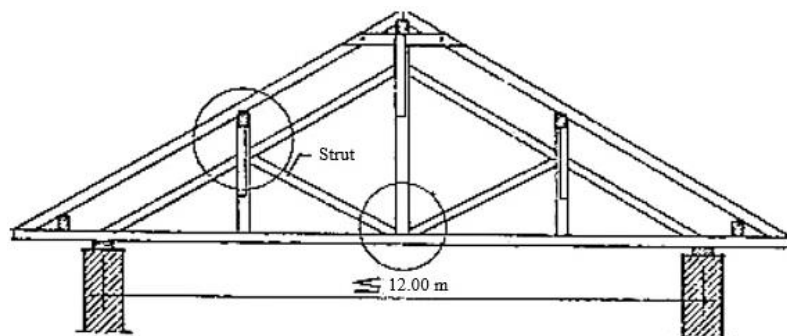

Figure 15. Hanging roof truss with three hangers (Özdemir, n.d.)

- **Mono-pitched roofs**

From structural point of view, this type of pitched roofs are similar to the flat roofs. Even the size of rafters and the space between them is been calculated in a similar way. The only difference is related to the bearings. In case of flat roofs, the joists are standing horizontally on walls; while for pitched roofs, rafters are located with a specified angle on the walls. This way of ordering the rafters, slides the external walls. In order to avoid this sliding force, all points of rafters which anchor it to the walls must be secured to the plate by using birdsmouth method. For this end, a notch should be made on rafters, however; it should be noted that this notch weakens rafter, thus; its length should not exceed 1/3 of the rafter's thickness. It is also important to mention that plate is a board which is anchored to the parapet. Thus; this method is only applicable for the roofs which terminate into parapets.

Mono-pitched roofs have less resistance against suction and in climates that high velocity winds are common, roof should be completely secured to the walls (Foster, 1994). [Figure 16]

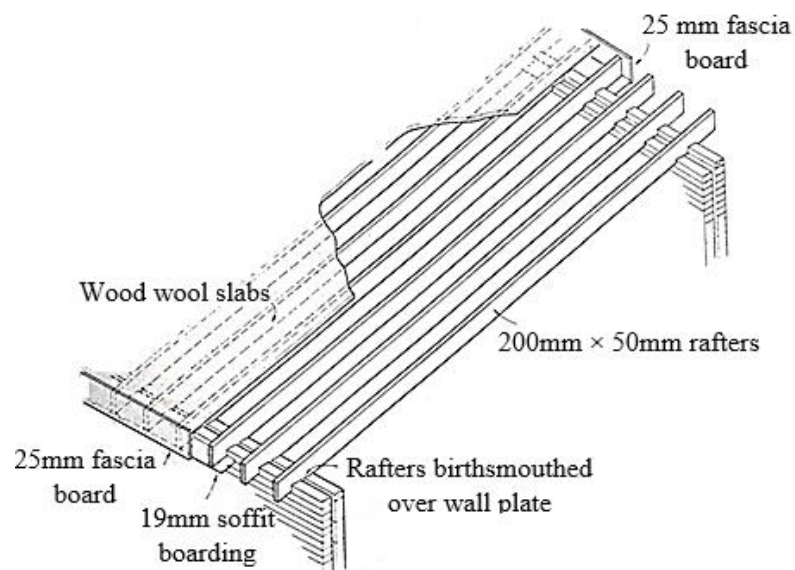

Figure 16. Mono-pitched roof (Foster, 1994)

- **Lean-to roofs**

This type of roofs is similar to mono-pitched ones. The only difference is that it is connected to a wall from one side. Similar to what is discussed before, the rafters which terminate into external walls should be anchored to the plates. In addition higher parts of roof should be connected to the wall with a corbel bracket. Other details are similar to what is mentioned for a mono-pitched roof (Foster, 1994).

- **Steel rigid frames**

Rigid structures are the ones which are constructed with columns and beams or girders and have rigid connections in between. The rigid connectors prevent from rotation in the edges of structural components. The figure illustrates a rigid structure. Various forms of rigid structures can be constructed. They cover up to 9-36 m spans and are generally used for single-story buildings or for especial functions such as light industrial buildings (Ching & Adams, 2001). [Figure 17]

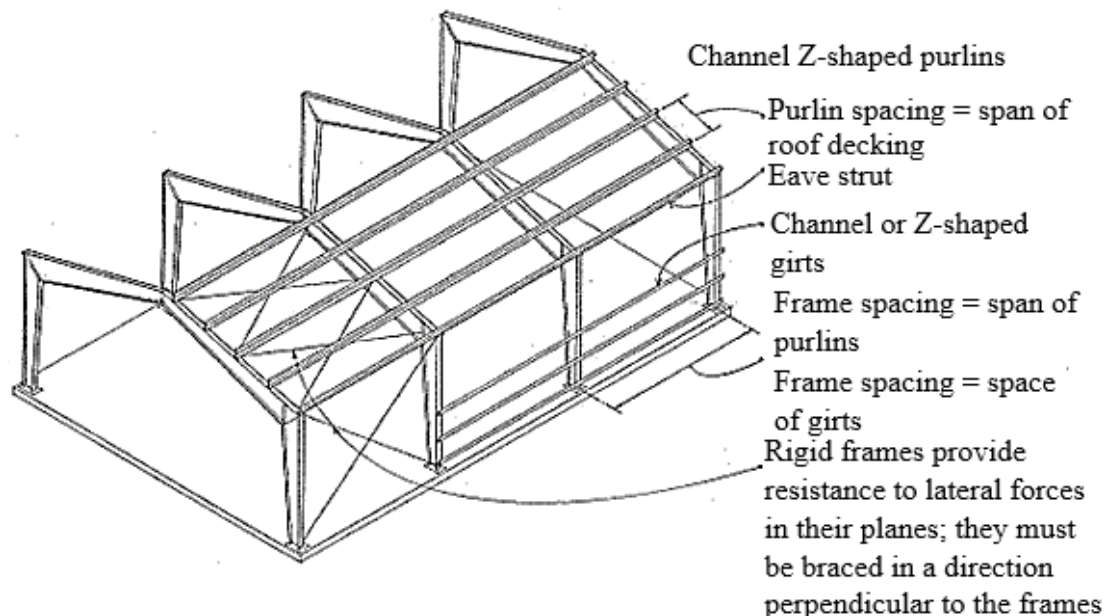

Figure 17. Steel Rigid Frame (Ching & Adams, 2001)

- **Truss**

The use of purlins in a roof structure necessitates supporting elements with proper spacing. When it becomes impossible to have supporting elements, rigid frames or triangular structures (called trusses) are other alternatives. Various considerations affect the truss form. One of them is the length of span. Trussed structures commonly cover longer spans compared to the beams and girders. 7-36 meters spans can be covered by trusses. Two types of trusses are discussed here: timber trusses and steel trusses.

Timber truss can be fabricated with different methods by nailing, gluing or bolting its members. The members can be lapped or butted which necessitates gussets or cover plates (Foster & Greeno, 2007).

Steel trusses are often applied to steel framed constructions and are suitable structures for industrial buildings or buildings with similar functions (Foster & Greeno, 2007). The connections in a steel truss are often with bolting or welding. The final product is in a triangular form with thin members and that is why gusset plates are normally used to provide connections (Ching & Adams, 2001). Different forms of trusses are shown in the following table [Table 6].

Table 6. Form of trusses (Ching & Adams, 2001)

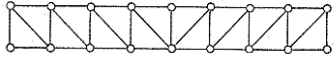
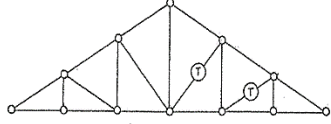
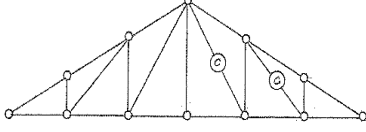
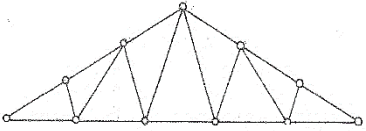
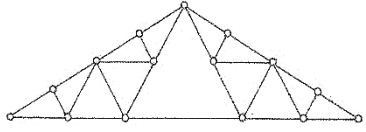
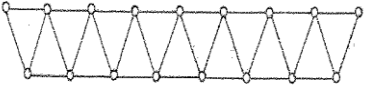
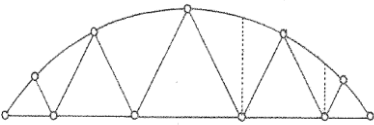
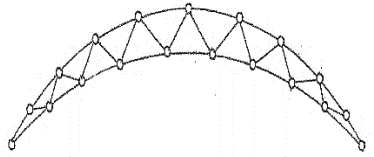
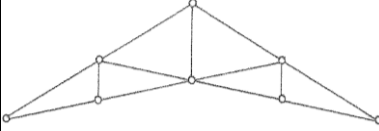
Flat truss	Flat trusses have parallel chords over the truss and beneath it. The strength of these trusses are lower compared to the other types.	
Pratt truss	Pratt trusses have better structural performance because longer web members are resisting tension.	
Howe truss	Howe is another type of trusses which has vertical members in tension and diagonal members in compression.	
Belgian trusses	All members of Belgian truss are diagonal	
Fink truss	Fink trusses are similar to the latter type, the only difference is that in order to reduce the length of compression members, sub diagonals are used.	
Warren truss	Warren trusses which have diagonal web members. In this respect, series of equilateral triangles are formed. Top chord is in compression, thus; by using vertical members the length can be reduced.	
Bowstring truss	Bowstring trusses have curved top and flat bottom chords.	
Crescent trusses	Crescent trusses are similar to the previous type, however; both the top and bottom chords are curved upwards.	
Scissors truss	Tensional members starting from the base of each top chord and continue to the intermediate part of the top chord of the opposite direction.	

Three dimensional roofs are often called ‘‘space structures’’ and all types of them are capable of covering internal spaces (Foster, 1994). In North Cyprus this type of structures are rarely applied; for this reason they are not discussed here.

2.4 Indoor air quality and Thermal Comfort

In recent years, indoor air quality and its impact on human health has been a subject of various studies. Designers are attempting to create buildings which consume minimum energy. The results are comfortable constructions, minimum costs and high indoor air quality (Jones, 1999). In this section, the major factors which affect roof design and guarantee thermal comfort and indoor air quality are discussed.

2.4.1 Thermal Insulation

In recent years implementing thermal insulation has become one of the major issues in conserving energy inside buildings. Insulations are one of the methods to reduce the amount of energy which is being used for heating and cooling buildings. Other methods are totally related to the amount of air movements, function of the building, and how the occupants use energy inside it (Max Fordham LLP, 2006).

The researches of Hançer and Özdeniz in North Cyprus have proven that roofs with insulation have illustrated better thermal performance. When insulating layer is located in the inner layers of the roof thermal performance is being increased. Standing timber roofs showed great results because the ceiling is being protected against direct solar radiations, however; the roof space should be ventilated permanently (Özdeniz & Hançer, 2005).

In case of flat roofs, beside thermal insulation, the reflection of the solar radiations from the roof’s surface becomes a major issue. In buildings which permanently use air

conditioning systems, proper ventilation should be implemented to prevent from condensation (Kießl, 2003). [Figure 18]

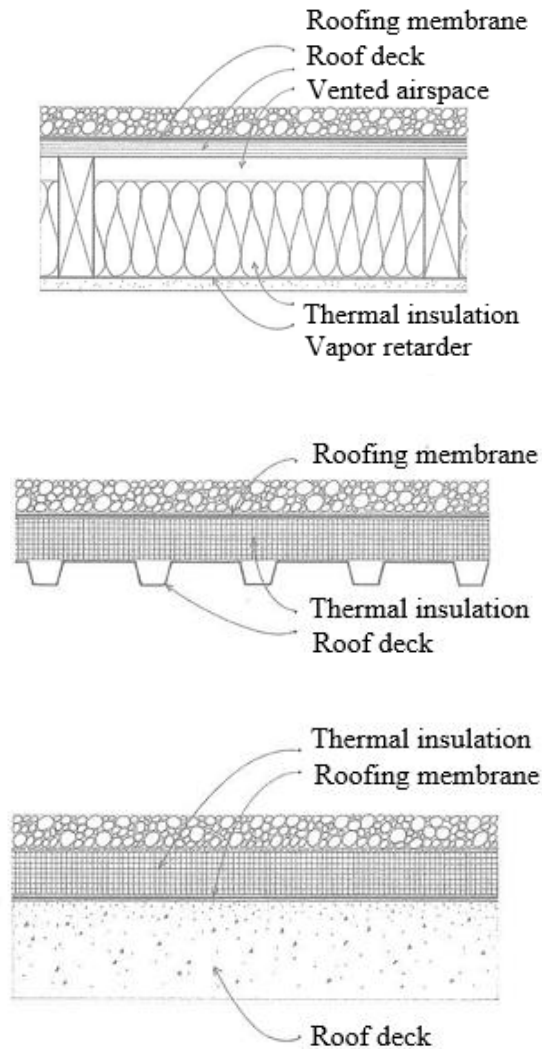

Figure 18. Position of thermal insulation in flat roofs (Ching & Adams, 2001)

In case of pitched roofs, there are two methods to insulate them: cold roof and warm roof. The cheapest and easiest method of installing thermal insulation is to place it over joists. This type of locating thermal insulation is called cold roof. Mineral wools, fiberglass and rock wool are the common insulation materials which are applied for cold roofs (Emmitt & Gorse, 2005). [Figure 19]

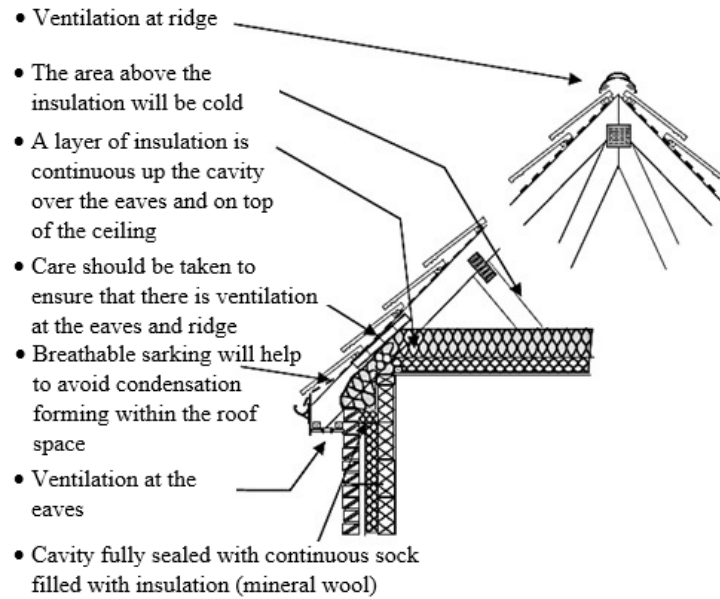

Figure 19. Cold roof: continuous insulation across ceiling (Emmitt & Gorse, 2005)

Warm roofs often cost more than the previous method. Thermal insulation is placed between or beneath rafters. Because the area of a pitched roof is more than a flat one, it asks for more material to insulate. The advantage of this method is that the space beneath roof is protected against temperature changes of the environment and provides dry space beneath it which is suitable to be used. The best application of thermal insulation in this method is shown in the following figure (Emmitt & Gorse, 2005).

[Figure 20]

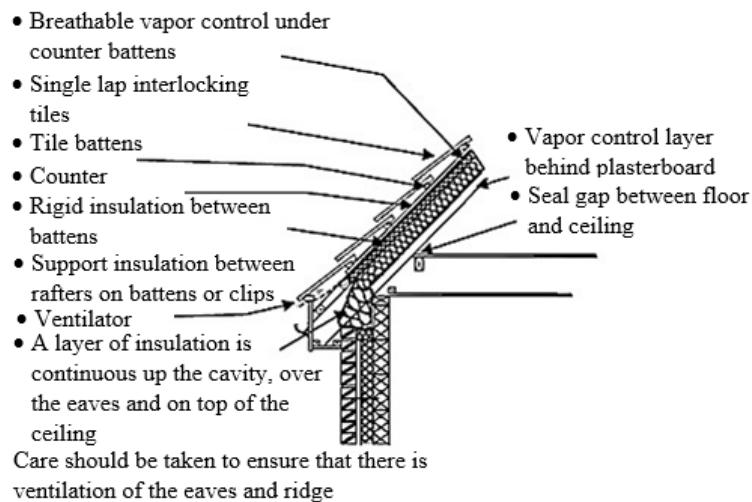

Figure 20. Warm pitched roof (Emmitt & Gorse, 2005)

2.4.2 Air -tightness

Building envelope should be sealed completely in joints and junctions to prevent from transferring heat. These precautions also minimize uncontrolled ventilation and improve indoor air quality. The importance of precise building details can be fully comprehend when it is understood that half of the amount of energy we use is to offset the heat which is lost as a result of uncontrolled ventilation (Kießl, 2003).

Penetration should be minimized in order to develop air tightness. It means that by proper workmanship and construction details, the risk of penetration will decrease noticeably (Kießl, 2003).

2.4.3 Moisture Control

Moisture control means precautions which are taken so that the moisture content does not go beyond the critical level in the building elements. Climatic conditions, humidity and temperature on two side of the element (inside and outside) affects its moisture content (Kießl, 2003).

The moisture content often increases in the following two conditions: 1. when the humidity levels reaches the dew point and condensation causes moisture in the building elements. 2. When building elements absorb moisture to the point that they are damaged and the performance of thermal insulation decreases (Kießl, 2003).

The precautions related to moisture control prevent from capillarity during rain falls and also the growth of algae and lichens. Besides, the risk for frustration decreases, however; they do not affect the structure's resistance against water or waterproof layers in flat roofs because in such cases permanent resistance is needed (Kießl, 2003).

A range of materials may control moisture in roof system: 1. Roof covering which can be constructed with tiles or slated should resist water penetration or etc.. 2. Roofing felt in a pitched roof is located beneath roof covering. Felt can be nailed or only overlapped to drain the water which is penetrated from the roof covering. In addition, it works as a vapor barrier during the construction process. 3. Vapor barrier is chosen according to the other roofing members and perform together with the thermal insulations as diffusion retardants (Kießl, 2003).

2.4.4 Roof ventilation

Ventilation in a roof prevents from moisture penetrations which possibly occur both during the construction process or its lifecycle. In addition, gaining heat as a result of solar radiation over the surface of a roof is being dissipated by a proper ventilation and provides satisfying thermal conditions. In this respect, a layer of ventilation over thermal insulation is being implemented which is in direct contact to the outside air. In pitched roofs this task is done by outlets and inlets which are located in the edges. Besides, a layer of ventilation can be applied beneath roof covering which is called ‘‘upper ventilation level’’ to guarantee proper air flow between roof layers and flow of air in motion is being set (Kießl, 2003).

Various factors may disrupt airflow between roof layers. Some of them are: unevenness, length of flow, the angle of slope, and projections. In additions, wind is another effective factor which can be studied independently in each climate (Kießl, 2003).

To prevent condensation in cold flat roofs, minimum 50mm space in order to allow the flow of outside air is essential. Openings should be made out of strips with 25mm

width. The following figure demonstrates flat roof ventilation (Emmitt & Gorse, 2005). [Figure 21]

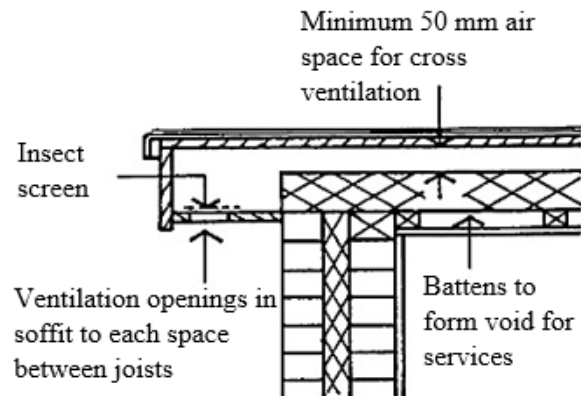

Figure 21. Roof ventilation (Emmitt & Gorse, 2005)

Ventilation is also important in the pitched roof to provide proper airflow. The temperature and pressure difference between roof layers and outside air, causes natural airflow regardless to the climate and the velocity of wind (Kießl, 2003). Ventilation techniques for pitched roofs are illustrated in the following figures. [Figure 22, 23]

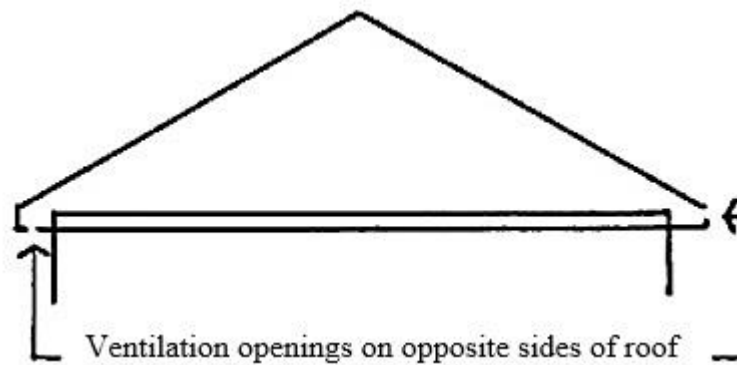

Figure 22. Roof ventilation (Emmitt & Gorse, 2005)

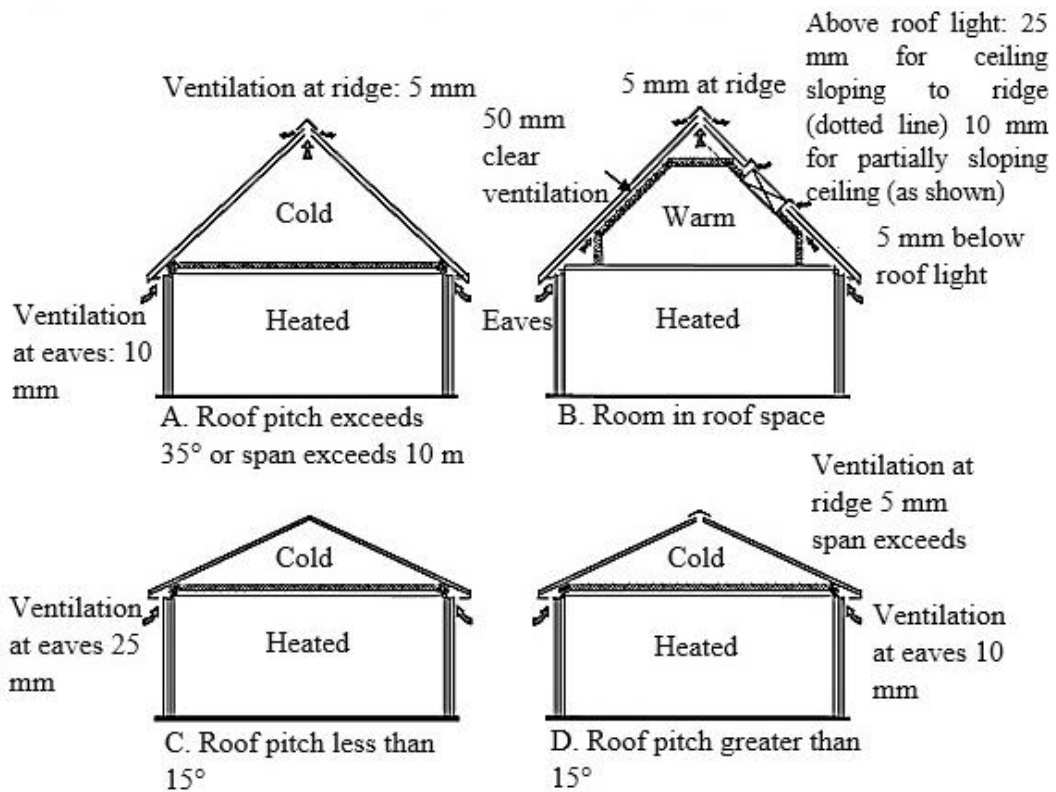

Figure 23. Pitched roof ventilation (Emmitt & Gorse, 2005)

2.4.5 Sound Insulation

Sound insulation for a building reduces negative impacts of the environment's noise inside the building so that the occupants are not disturbed or annoyed. The type of sound insulation should be decided during planning level of the building design so that sound bridges can be totally prevented. Proper workmanship and construction details can minimize sound bridges and the amount of insulation which is essential for each region is listed in the building codes. Calculation and measurement is required to find minimum insulation that is essential (Kiessl, 2003).

2.4.6 Fire Protection

When the term *fire protection* is discussed for a building element, three major aims should be met: 1. to protect the occupants 2. to protect the occupants' properties 3. To prevent the spread of fire to the surrounding buildings. In the latter case, the construction materials of building components and their design in such a way that

create maximum resistance become the major issue. Additionally, roofs should be protected against flying sparks and radiant heat which is also met by the proper materials and design (Kießl, 2003).

2.4.7 Corrosion Protection

Corrosion is generally related to the metal elements which are applied for constructing a building component especially when it is exposed to the surrounding environment. In addition, structural elements have the risk of corrosion as a result of ventilation or diffusion.

Beside chemical corrosion, galvanic corrosion is also possible when different metals are in direct contact. By utilizing coatings, the material can be protected against corrosion to a great extent, however; the effect of different metals on each other should be mentioned when they are located alongside (Kießl, 2003).

2.5 Roof Materials

Beside construction method and durability, cost is one of the most important factors in choosing materials for construction. Today, in many countries materials' environmental impacts (both during production and its lifecycle) are considered. Beside initial cost, the amount of energy which is required to produce material, disposal and maintenance costs are also important factors in selecting among various types of materials (Schunck et al., 2003).

The total cost of a building material consists of the cost of extracting raw materials, transportation, storing, producing and depositing. Some extra expenditure is added when the color or texture of the material should be changed. In recent years, automation in construction has created a great variation of different materials and

qualities. Besides, by using automation, the amount of energy which is required and the quantity of raw materials are being noticeably reduced. The total cost of a material is generally divided into three parts: erection, lifetime and disposal. For example, when considering roof construction, the total cost is highly influenced by the erection expenditures (Schunck et al., 2003).

The second part is related to the lifetime costs. Today, economical problems have forced the professionals to consider lifecycle costs of the implemented materials. Constructors are obliged to choose materials which require less maintenance as a result of increase in the repairing and maintenance costs. Durability of a material in addition to its ability of being repaired and changed is vital for cutting down the lifetime costs. In addition, climatic issues become an important factor as it influences the lifecycle costs of a specific material (Schunck et al., 2003).

The third part is related to the deconstruction costs. In recent years, with introduction of indoor air quality in buildings and its effects on human health (such as insulations and wide use of asbestos), considering environmental impacts of the selected materials becomes essential. The recyclability of the material and ease of disposal can help the decision maker to choose the optimum material which have minimum impacts on the environment (Schunck et al., 2003).

2.5.1 Concrete

‘‘Concrete is a mixture of cement, aggregates and water together, with any other admixtures which may be added to modify the placing and curing process or the ultimate physical properties (Lyons, 2004)’’. Concrete can be reinforced or prestressed with steel. A good-quality concrete is made out of a suitable combination of cement

and water and compacted properly. A good-quality concrete is highly durable, however; in some cases there is a risk of deterioration or internal degradation (Lyons, 2004).

Generally there exist an amount of sulfate in the soil, existence of soluble sulfate in water causes sulfate attack in the concrete. Sulfate attack results in cracks or reduces strength of the concrete which also means high risk for more sulfate attacks (Lyons, 2004).

The resistance of the concrete against fire is high. Its strength does not change noticeably until 250°C, however; when the temperature goes beyond this amount and reaches up to 450°C the strength begins to decrease. Concrete illustrates insulating performance, thus; its temperature does not increase quickly. Aggregates have a great role in the fire resistant quality of concrete.

The chemical performance of concrete and its acid resistance is totally related to its quality. By adding some mixture, chemical attacks can be prevented. Carbonation occurs when CO₂ is being absorbed by the concrete which is not hardened yet. The mixture begins to react in its surface and the process is totally affected by the concrete's quality (Lyons, 2004).

2.5.2 Reinforced Concrete

Concrete can resist compression loads up to 20-40 N/mm², while for high quality concrete it goes up to 100 N/mm². However the tensile resistant of concrete is very low (only %10 of its compression resistance), thus; by applying steel material which is well-known for its tensile resistance, the tensile performance can be increased. The

location and the amount of steel which is required become two major issues in this case (Lyons, 2004).

The fire resistance of reinforced concrete is totally affected by the amount of concrete. It should be mentioned that, when more than 40 mm concrete is used, additional reinforcement becomes essential (Lyons, 2004).

Different methods can be used to reinforce concrete. Pre-tensioning is when steel is being tensioned before curing the concrete, while post-tensioning is when the concrete is being cured first and then the steel is tensioned (Lyons, 2004).

- **Concrete roofing tiles and slates**

These types of roof coverings are generally applied to the pitched roofs and are the cheapest ones which have acceptable appearance. *Plain tiles* are appropriate for slopes less than 30° and *ornamental tiles* are used for slopes which are less than 70°. Another form of tiles are *interlocking tiles* which can cover lower slopes and are available in different colors such as brown, red, rustic and grey (Lyons, 2004). [Figure 24]

2.5.3 Timber

Timber is an original material which is being used to construct buildings for a long time. Because of its versatility, appearance and available variety it is widely used. Additionally, timber is a renewable material which has little environmental impact during its production process.

The moisture movement for timber varies in the direction of different axes. Timber has three axes and the maximum moisture movement is in direction of the tangential ax. In addition, moisture movement changes based on the level of humidity, it is measured to vary between %60 - %90 in 25°C (Lyons, 2004).

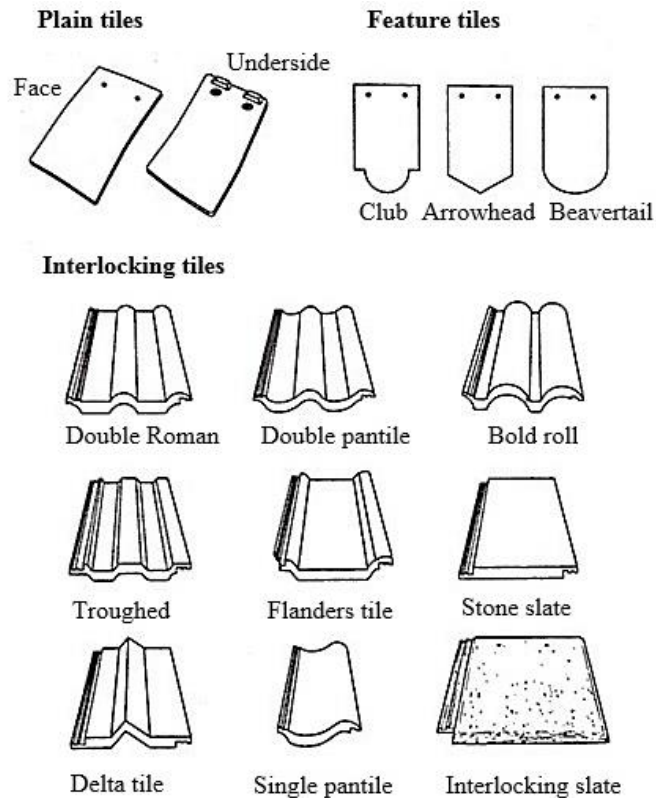

Figure 24. Concrete roofing tiles and slates (Lyons, 2004)

Timber is a natural material which always has natural defects. Generally timber defects are divided into conversion, natural and seasoning. Besides, deterioration, fungal and insects also affect its strength (Lyons, 2004).

- **Laminated veneer lumber**

This material is suitable for columns, beams, purlins, and trusses. I-section joists can be produced by laminated veneer lumber which is also a proper material for webs and flanges in flat and pitched roofs. In order to produce laminated veneer lumber, timber strands are being laminated by using polyurethane resin and then logs are cut in timber strands, finally; resin is treated (Lyons, 2004).

- **Plywood**

Plywood is being produced by laminating thin layers of timber so that it reaches the desired thickness. It is highly applied in building construction because of its duration

and appearance. Plywood is available in form of boxes or I-section building elements. Plywood has high shear strength and its box form is commonly used in pitched or arched roofs. Long spans can be covered by plywood when the softwood is bonded together and creates a T or I shaped beam. When the thickness of the material is 8-10 mm, it can be used for sheeting (Lyons, 2004).

- **Particle boards**

Particle boards are panel materials which are made out of heated particle woods, flaxes, etc. A great amount of them are used in producing furniture and flooring. When particle boards are applied for flat roof decking or as structural elements, they should become moisture resistant. In addition, cement-bonded particle boards are suitable materials for soffits and external sheeting (Lyons, 2004).

- **Fiberboards**

Fiberboard are produced by wood or other fiber materials under heat and pressure. The dense form of fiberboards are called hardboard. Tempered hardboards are proper structural and beam materials. They can also be used for cladding, fascia and soffits.

- **Wood wool slabs**

Wood wool slabs are created by compressing the strands of stabilized fibers. Fibers can be coated with Portland cement and the B-type of the material has load bearing ability as a roof deck. ‘‘Wood wool slabs form a suitable substrate for flat roofs finished with built-up bitumen sheet, asphalt or metals’’ (Lyons, 2004).

- **Thatch and shingles**

Previously, thatch was the common material for roof covering and until the 19th century it was still used in rural regions. Today, the material is being rarely used in three forms: water reed, long straw and combed wheat reed. Red cedar is suitable for

cladding and roofing because of its high strength. Its color gives warmth to a building and has an acceptable appearance (Lyons, 2004).

2.5.4 Ferrous and Nonferrous Metals

Metals are widely used in a building construction in form of steel, aluminum, copper, lead and zinc. In recent years, different alloys of metals and coatings are available to protect metals. Production of metals requires a great amount of energy which can be offset by recycling them (Lyons, 2004).

- **Steel**

Each type of steel have different qualities and various types of them are available in the construction industry. Different types of steel can be produced by changing the amount of carbon, alloying or the heat.

Hollow sections of flat steel material are rounded slowly to produce circular, oval, square or rectangular forms. Steel structures can become resistant against fire by applying insulation, the second method is to use fire engineering techniques (Lyons, 2004).





- **Profiled Steel Sheeting**

The standard form of profiled steel sheeting is trapezoidal and its thickness is chosen according to the length of span and the load it should resist. The curved form of profiled sheeting is suitable for eaves and soffits. The more rigid the steel, the less flexible it becomes so that their application in some parts of building is limited. [Table 7]

Steel should be coated with different materials to become protected. Zinc-coated steel, as an example, is resistant against corrosion, and aluminum-zinc alloy coated, is more

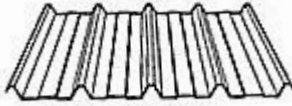
durable than original steel so that it can be used as substrate for organic coated steel. Organic coated steel is generally applied as cladding and roofing material (Lyons, 2004).

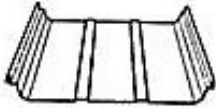
Table 7. Typical profiles for sheet-steel roofing (Lyons, 2004)

Roof cladding profiles		
		
		

- **Steel Tiles and Slates**

Steel tiles have the ability to be refurbished and are lighter than traditional materials. They can cover slopes between 12 to 90°, in addition; they are available in different traditional colors and ventilation accessories (Lyons, 2004).

2.5.5 Bitumen and Flat Roofing Materials

‘‘Built-up bitumen sheet system, mastic asphalt, single-ply plastic membranes and liquid coatings’’ are the roofing materials which also provide the flat roof with vapor barrier. All these types of roofing materials require roof decking (Lyons, 2004).

In cold decking systems, the water resistant layer remains over the decking and is supported by the structure of a roof. In this case, thermal insulation is located over the

plasterboard ceiling. This type of roof necessitates permanent ventilation otherwise there is a risk for condensation. For warm-deck roof systems, thermal insulation is situated between deck and it covers and insulates both the deck and the roof structure. In such circumstances, the insulation is located directly beneath the vapor barrier, thus; it should have the ability to support the imposing loads. For inverted roofs, thermal insulation covers both the deck and the waterproof layer, so that the dead load of the roof will increase. This type of roof assembly is suitable for concrete roofs or the ones which are heavy (Lyons, 2004).

- **Built-up Roofing**

Built-up roofing is produced by several layers of bitumen sheets. This material is applicable to precast or in-situ concrete roof systems. It can also cover ‘cement screeds, plywood, timber, particle board, wood wool slabs and profile metal decking’’. The first layer should be set in the direction of falls in flat roofs. For pitched roofs, the first layer must be nailed to the decking (Lyons, 2004). [Figure 25]

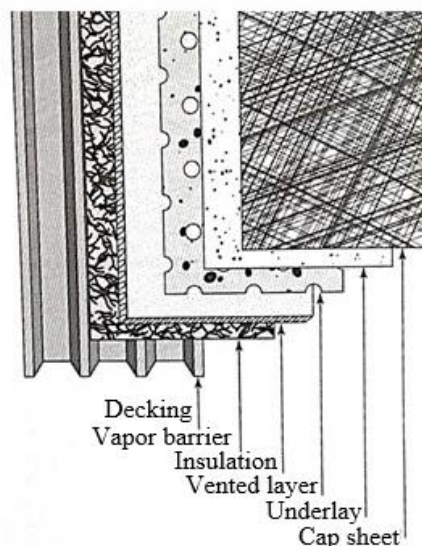

Figure 25. Built-up roofing system (Lyons, 2004)

- **Mastic asphalt**

Mastic asphalt is produced by blended bitumen-based materials and are brought to the construction site in form of blocks which should be melted. The material can cover both flat and pitched roofs and concrete, plywood, chipboard, wood wool slabs and sheet metals are suitable types of decks for this material. Mastic asphalt is the best choice for inverted roofs and the ones with extreme insulation because it prevents from thermal shock (Lyons, 2004).

- **Single-ply roofing system**

Single-ply roofing is a continuous membrane with a thickness of 1-3 mm. It can cover both flat and pitched roofs and can provide a total resistance against water to the roof system (Lyons, 2004). [Figure 26]

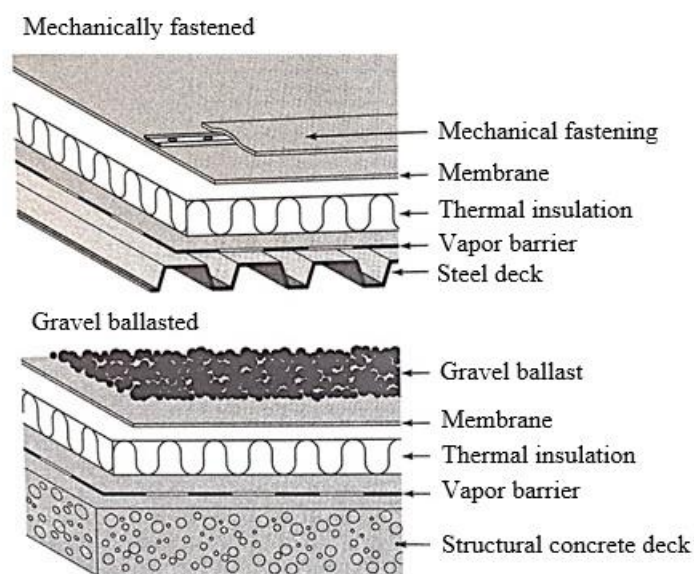

Figure 26. Typical single-ply roofing system (Lyons, 2004)

- **Liquid coatings**

Liquid coatings are made out of bitumen-based and polymer-based materials. Instead of re-roofing, they are mostly used to remedy the failed flat roofs. A wide range of

colors of liquid coatings are available today and the only problem related to applying this material is that it can only support light pedestrian traffic (Lyons, 2004).

2.5.6 Roofing Tiles



















Roofing tiles are often made out of clays which are similar to bricks. A wide range of bright colors of low and high gloss finishes are available in the market, in addition; plain tiles can be implemented as roofing members (Lyons, 2004). [Table 8]

2.5.7 Insulation Materials

Thermal and sound insulations are divided into many groups according to their function, physical form and the material in which they originate. Lyons divides the insulation materials into ‘‘structural insulation materials, rigid and semi rigid sheet and slates, loose fill, blanket materials and applied finishes and aluminum foil.’’ Another categorization can be organic and in-organic insulations. Different types of in-organic insulation materials are as followings:

1. Foam Concrete: can be installed without compaction and is a suitable material for insulating floors and flat roofs.
2. Lightweight aggregate concrete: is suitable for insulating and load bearing.
3. Gypsum plaster
4. Wood wool slabs: are made out of wood fibers and cement. Wood wool slabs are fire resistant and their ability to perform both as load bearing components and insulations make them proper decking materials. The other advantage of using them is that they are also sound insulations.
5. Mineral wool: is a non-combustible material which originates from volcanic rocks. The major advantage of using mineral wool is that it is rot resistant and does not produce CFCs. A wide range of mineral wools are available and its

Table 8. Roof tiles, feature tiles and plain tile fittings (Lyons, 2004)

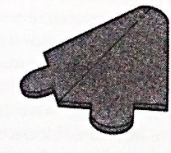
Standard tiles					
Plain		Roman		Pantile	
					
Feature tiles					
Club	Fishtail	Arrowhead	Bullnose	Beavertail	
					
Plain tile fitting					
Gable tile	Eave tile	Bonnet hip	Arris hip	Valley	Cloak verge tile
					
External & internal 90° angle tile	External & internal 90° angle tile	Half round ridge	Angle ridge	Ornamental gable tile	Ornamental hip (club)
					

rigid slabs are suitable for flat and warm pitched roofs. In addition, there are some weather resistant forms of mineral wools which are commonly used for inverted roofs and are fire resistant.

6. Glass Wool: in form of rolls insulates roofs and floors. Also a wide range of glass wools are available in the market. The compression-resistant form of this material is suitable for slabs and PVC-coated rigid panels are used for factory roof lining. The fire resistant quality of this material is similar to the previously discussed insulation materials.
7. Foamed glass blocks: is a durable material with high fire resistance. It is also known for its ability to support compression loads. It is water proof and suitable for roofs.
8. Exfoliated vermiculite: is a proper material for insulating lofts.
9. Glass and multiple glazing: has high sound and thermal insulating ability.
10. Calcium silicate: has a high thermal resistance (Lyons, 2004).

Organic insulation materials are also discussed in the following paragraphs:

1. Cork Products: are often used as roof thermal insulations and are not harmful to the environment. When installed with hot bitumen in flat roofs, cork product insulations become unaffected.
2. Sheet wool: is a renewable material which absorbs and loses water. This helps the material to prevent from condensation and makes it suitable for ventilated lofts. Sheet wools can be located between rafters and joists, however; when sheet wools absorb water their thermal performance highly decreases.
3. Cellulose insulation: is made out of recycled papers and newspapers which are treated with different materials. As cellulose materials are recyclable, they have

minimum impact on the environment. Cellulose is often used for insulating lofts and where eave ventilation is essential.

Some other types of organic insulation materials are hemp and coconut fiber, flax, fiber insulation board, expanded polystyrene, extruded polystyrene, expanded PVC, polyurethane foam, urea-formaldehyde foam and phenolic foam (Lyons, 2004).

2.6 Roofs' Construction Details

The major function of a roof is to protect building from adverse weather conditions, rain, snow and sun. Roof is a member of the building envelope which has the largest surface in contact with solar radiation and can be constructed with different materials and details to protect the building. In this section, roofs are studied in two wide categories which are flat and pitched ones. The major difference between these two which results in various construction details is that steep slope roofs drain rainwater quickly thus their roofing material can be small units. Installing small units is easier and cheaper comparing to the other roofing materials and can be repaired easily whenever required.

2.6.1 Flat Roof Construction Details

Roofing materials for flat roofs are continuous and requires precise workmanship because small mistakes may result in puddles. The advantage of installing continuous roofing materials is that they can cover all buildings regardless to the forms and geometry of the plans and that they can be used as balconies or landscapes (Allen & Iano, 2004). Flat roofs require low slopes to drain rainfalls, otherwise; ponding occurs on the roof surface and the pressure which is imposed to the roof as a result of ponds causes deterioration (Emmitt & Gorse, 2005).

The general form and different components of a flat roof are shown in the following figure. These types of roofs have a slope between 0° to 10° (Chudley, 1989). [Figure 27]

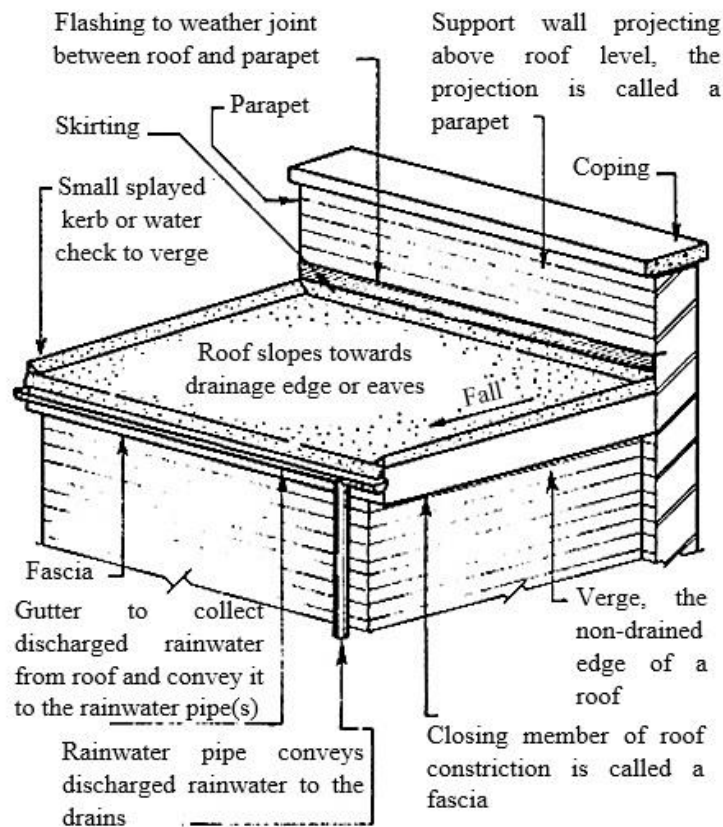

Figure 27. Flat roof and its components (Chudley, 1989)

Flat roofs are often constructed with steel or timber decks which should be in form of well-seasoned lumber. Joints are tongue and grooved and the cracks should be covered with metals. Another method is to apply plywood or structural wood-fiber decks which are dense enough to support the imposed loads. Cast-in-place concrete is the other decking material and should have falls in the direction of the drain and cured properly. In addition, precast concrete or light weight insulating concrete which is totally cured can be installed (Ching & Adams, 2001). The roofing materials for flat roofs are

“built-up bitumen felt, mastic asphalt, non-ferrous sheet metals, lead, copper, zinc and aluminum (Barry, 1980)”.

- **Lead sheet**

Lead is a heavy material and should be installed in form of sheets with high thickness, however; it can be shaped in different forms. The edges of the sheets are overlapped to the wood in the direction of fall which is called wood roll. Drips have a depth of 50 mm and are nailed with a 50×25mm fire batten. Apron should be fixed in such a way that it is not lifted with the imposed loads of the lead (Emmitt & Gorse, 2005).

When roof terminates to a parapet, the rainwater should be collected in the lowest part. To do so, a timber frame is constructed, then covered with lead and jointed in drips. When an external pipe is desired, gutter becomes in form of a cesspool (Emmitt & Gorse, 2005). [Table 9]

- **Copper sheet**

Copper is a durable material which can be formed and bended. Its life time is similar to lead and is produced with 0.6 mm thickness. The minimum slope for copper sheet is 1 in 60 which can be applied by installing firrings. Previously, it used to be installed by wood rolls. The following detail illustrates a flat roof with copper sheet (Emmitt & Gorse, 2005). [Figure 28]

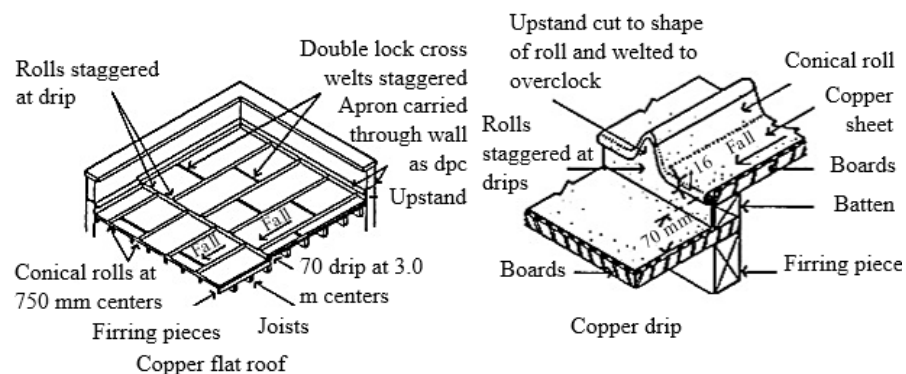
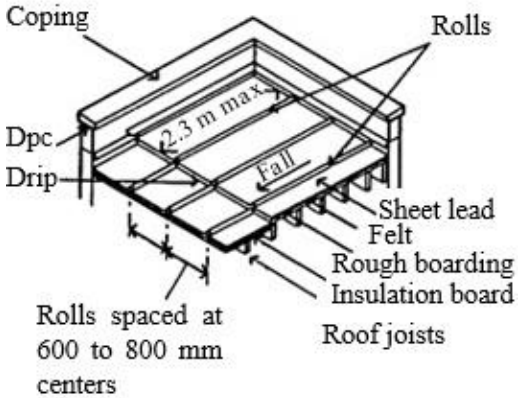
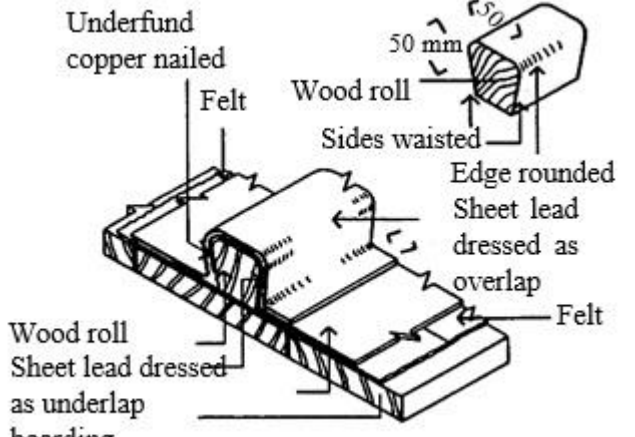
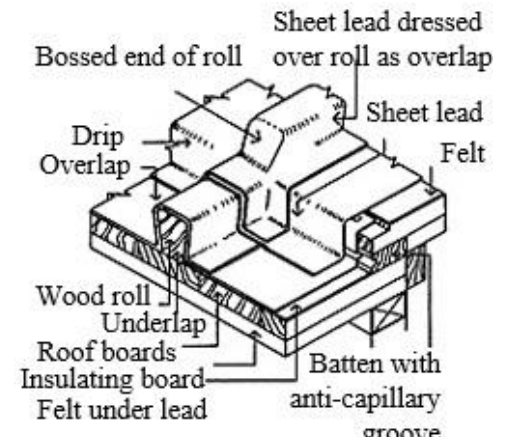
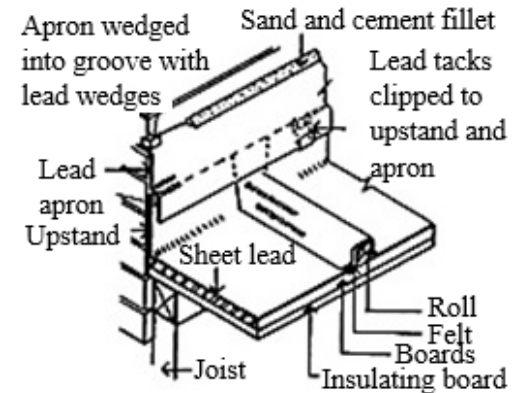
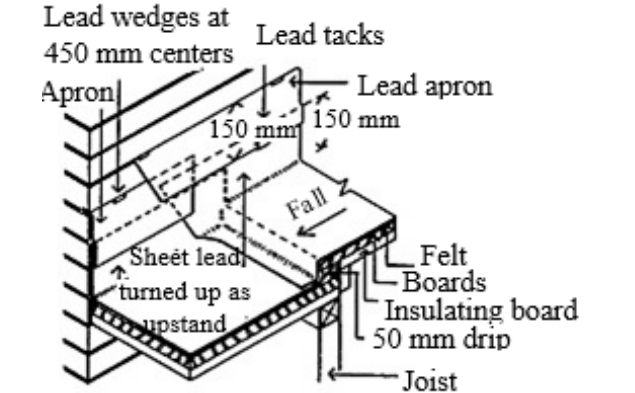
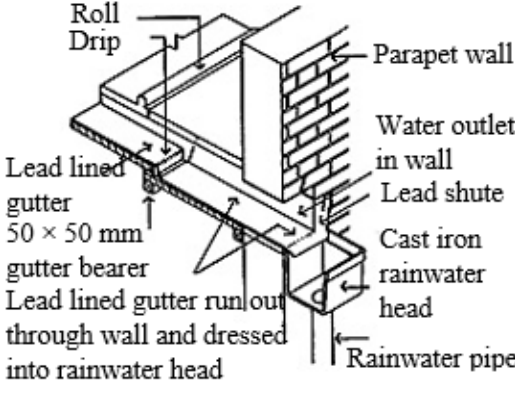

Figure 28. Copper flat roof (Emmitt & Gorse, 2005)

Table 9. Construction details of a flat lead roof (Emmitt & Gorse, 2005)

Flat lead roof	Wood rolls	Drip
 <p>Coping</p> <p>Rolls</p> <p>2.3 m max.</p> <p>Fall</p> <p>Dpc</p> <p>Drip</p> <p>Sheet lead</p> <p>Felt</p> <p>Rough boarding</p> <p>Insulation board</p> <p>Roof joists</p> <p>Rolls spaced at 600 to 800 mm centers</p>	 <p>Underfund copper nailed</p> <p>Felt</p> <p>Wood roll</p> <p>Sides waisted</p> <p>50 mm</p> <p>Edge rounded</p> <p>Sheet lead dressed as overlap</p> <p>Felt</p> <p>Wood roll</p> <p>Sheet lead dressed as underlap</p> <p>boarding</p>	 <p>Sheet lead dressed over roll as overlap</p> <p>Bossed end of roll</p> <p>Sheet lead</p> <p>Felt</p> <p>Drip Overlap</p> <p>Wood roll</p> <p>Underlap</p> <p>Roof boards</p> <p>Insulating board</p> <p>Batten with anti-capillary groove</p> <p>Felt under lead</p>
Junction of roll and upstand	Junction of drip and upstand	Rainwater outlet
 <p>Apron wedged into groove with lead wedges</p> <p>Sand and cement fillet</p> <p>Lead tacks clipped to upstand and apron</p> <p>Lead apron</p> <p>Upstand</p> <p>Sheet lead</p> <p>Roll</p> <p>Felt</p> <p>Boards</p> <p>Insulating board</p> <p>Joist</p>	 <p>Lead wedges at 450 mm centers</p> <p>Lead tacks</p> <p>Apron</p> <p>Lead apron</p> <p>150 mm</p> <p>150 mm</p> <p>Fall</p> <p>Sheet lead turned up as upstand</p> <p>Felt</p> <p>Boards</p> <p>Insulating board</p> <p>50 mm drip</p> <p>Joist</p>	 <p>Roll Drip</p> <p>Parapet wall</p> <p>Water outlet in wall</p> <p>Lead shute</p> <p>Cast iron rainwater head</p> <p>Rainwater pipe</p> <p>Lead lined gutter</p> <p>50 x 50 mm gutter bearer</p> <p>Lead lined gutter run out through wall and dressed into rainwater head</p>

Conical rolls in the direction of fall can be made out of softwood and has a cone-shaped section. This form of section makes it easier to shape the metal in a way that is required [Figure 29].

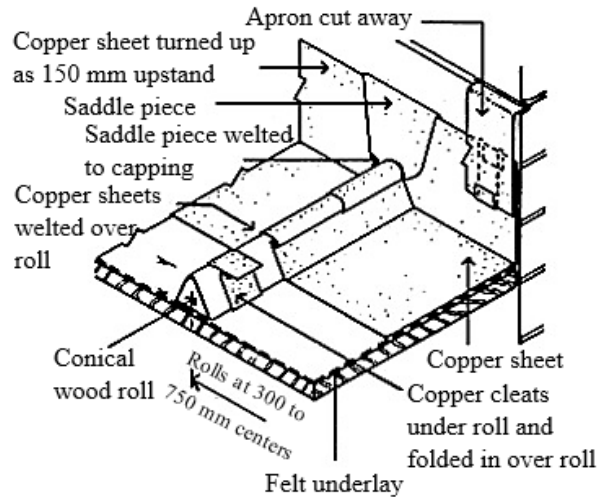
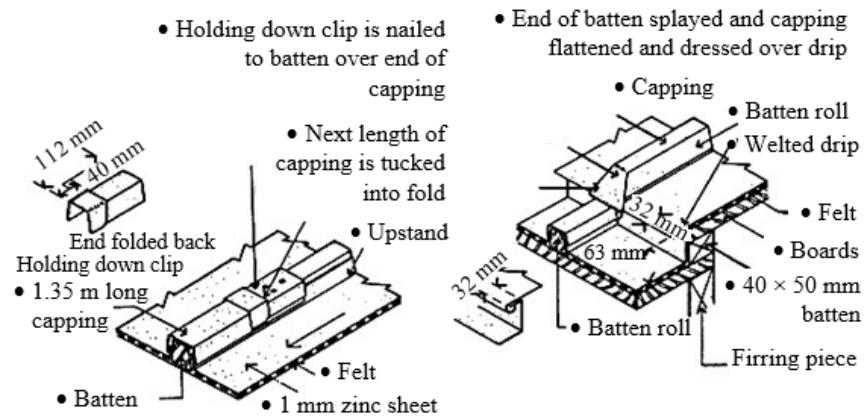

Figure 29. Conical roll (Emmitt & Gorse, 2005)

- **Zink sheet**

Zink is a light grey material which its sheet form is suitable for covering roofs. It is the cheapest metal to apply as a roofing material and bended hardly compared to other metals which are discussed here, because there is a risk of cracking when it is bent.

[Figure 30]



A. Zinc batten rolls
 B. Zinc drip
 Figure 30. Zinc batten rolls and drip (Emmitt & Gorse, 2005)

- **Mastic asphalt**

The other materials which perform as waterproof layers for flat roofs are asphalt and bitumen felt. Asphalt (often called mastic asphalt), has low softening point and it is highly resistant against water penetration. The heated asphalt is poured into molds and becomes solid when it is cooled. Asphalt is heated in-situ and spread over the roof in two layers so that the final thickness reaches 20 mm. When the material is cooled, a continuous waterproof layer is produced. When there are no parapets, the cover continues over the external walls (Emmitt & Gorse, 2005). [Figure 31]

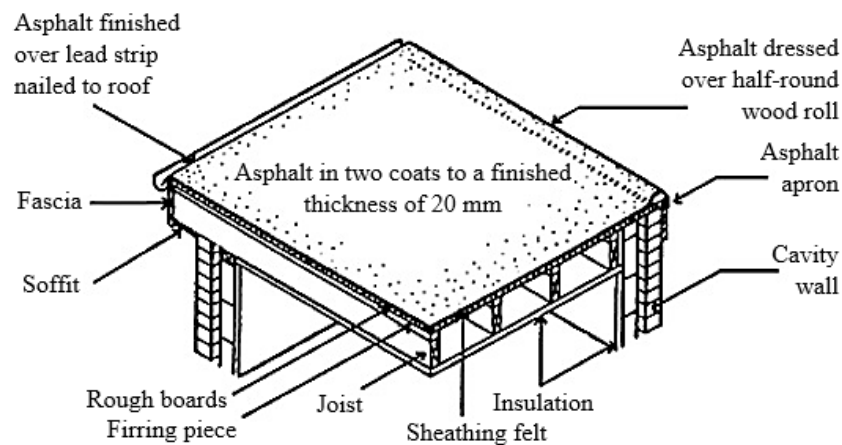

Figure 31. Asphalt covered flat roof (Emmitt & Gorse, 2005)

When roof terminates into a parapet wall, or to the walls of the surrounding buildings, asphalt skirting with the height of 150 mm should be turned into external walls [Figure 32].

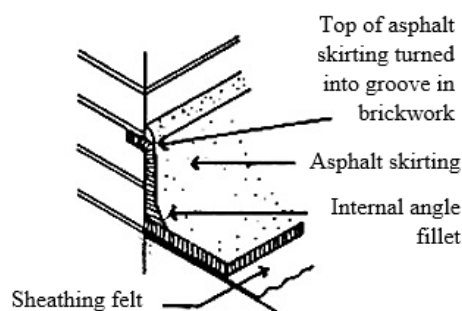

Figure 32. Asphalt skirting (Emmitt & Gorse, 2005)

- **Built-up bitumen felt**

The word felt is used for fibers that are spread at random around a large, slowly rotating drum on which a mat of loosely entwined fibers is built-up. The mat is cut, rolled off the drum and compressed to form a sheet of felted (matted) fibers (Emmitt & Gorse, 2005).

There are different types of felts which are available, sheathing and hair felts, fiber base bitumen felt, glass fiber base and bitumen felts are some examples. These felts are spread over the roof in three layers.

In order to lead the rainwater into gutters, a slight slope is essential. The gutter should be placed one side of the roof. In case of inverted roofs, the insulation is installed beneath covering and cover is directly affected by the changes of outside temperature. When bitumen-felt or asphalt coverings are applied, these temperature changes result in cracking. In such circumstances, the most beneficial location of the thermal insulation is over the covering. The insulation should be dense and does not absorb water (Emmitt & Gorse, 2005). [Table 10]

- **Reinforced concrete flat roofs**

Roof should be designed in such a way that it resist wind, snow and its own weight simultaneously. In order to provide a flat surface for the roof covering, concrete should be power floated and the required slope is produced by using cement sand screed. Asphalt is a proper material to cover reinforced concrete roofs because of its stability and being free of shrinkage while timber roofs are often covered by built-up material. When concrete roof is covered by built-up bitumen felt, water may evaporate from the screeded concrete and result in blisters beneath the bitumen felt (Emmitt & Gorse, 2005).

Table 10. Construction details of a bitumen-felt flat roof (Emmitt & Gorse, 2005)

Built-up felt covering to timber flat roof	
<ul style="list-style-type: none"> • Dpc • Second and third layers with lapped joints full bonded to underlayer • First layer lapped 50 mm and fully bonded • Timber joist, insulation, furring and boarding 	
<p>Eaves gutter</p> <ul style="list-style-type: none"> • Three layers of roofing felt on boards, insulation and vapor barrier • Gutter • Timber fascia board • Lightweight blocks carried up between joists as insulation 	<p>Upstand and flashing</p> <ul style="list-style-type: none"> • Dpc • Copping • Metal flashing built into wall and dressed over upstand • Bitumen felt dpc • Three layers of roofing felt • Angle fillet • Timber boards on insulation board and vapor barrier
<p>Inverted roof abutting an internal wall</p> <ul style="list-style-type: none"> • Dpc-cavity tray • Aerated concrete block • Mineral aggregate • Filter layer • Paving slabs • Insulation • Bitumen felt • Cavity fill continues up the full height of the cavity 	<p>Inverted roof abutting parapet wall</p> <ul style="list-style-type: none"> • Aerated concrete block, low density with good thermal insulation, prevents cold bridge • Dpc-cavity wall • Cavity fill continues up the height of the cavity

Table 11. Construction details of asphalt covering concrete flat roof (Emmitt & Gorse, 2005)

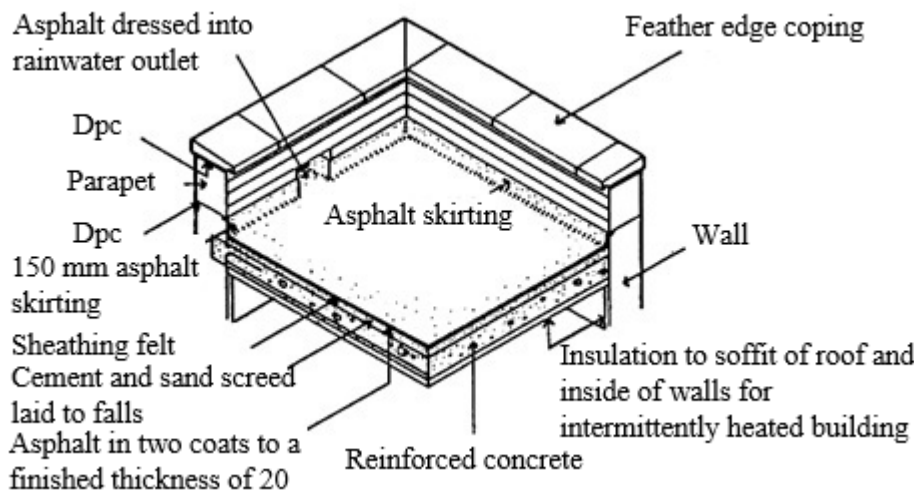
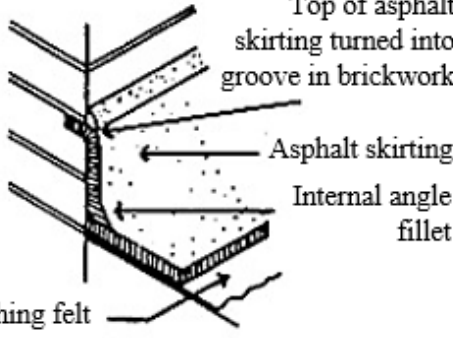
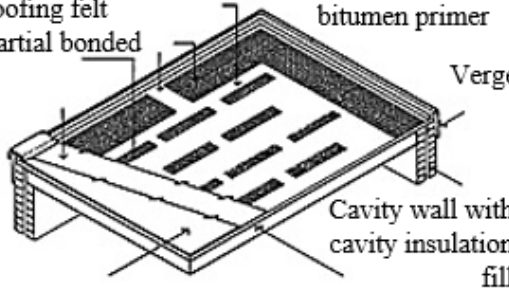
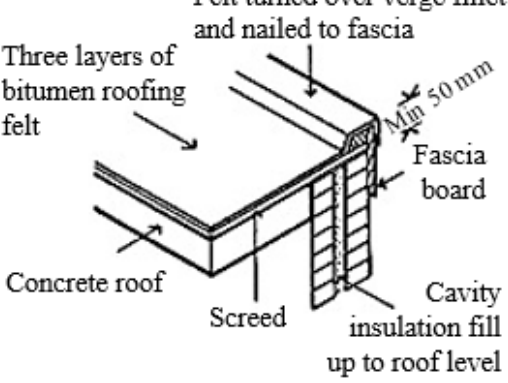
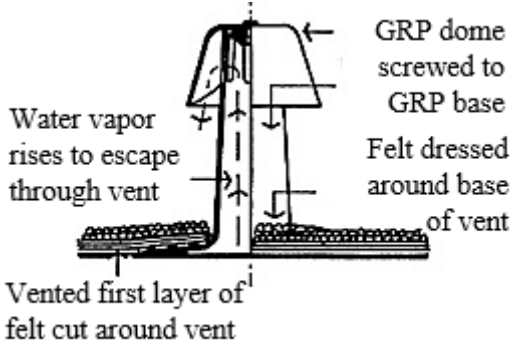
Asphalt covering to concrete flat roof	
	
Asphalt skirting	Partial bond of felt roofing to concrete
	
Verge	Ventilator
	

Ventilation can be provided by plastic ventilators which are located behind felts or in felt overlaps and verges. In this case, apron flashing should be installed over them (Emmitt & Gorse, 2005). [Table 11]

- **Position of thermal insulation**

As it was mentioned before, thermal insulation can be installed with three different methods to a flat roof. The details are illustrated in the hygiene and thermal comfort section. In order to prevent thermal bridges, the beneficial details are the ones which have unite thermal insulation for roofs and walls (Emmitt & Gorse, 2005). [Figure 33]

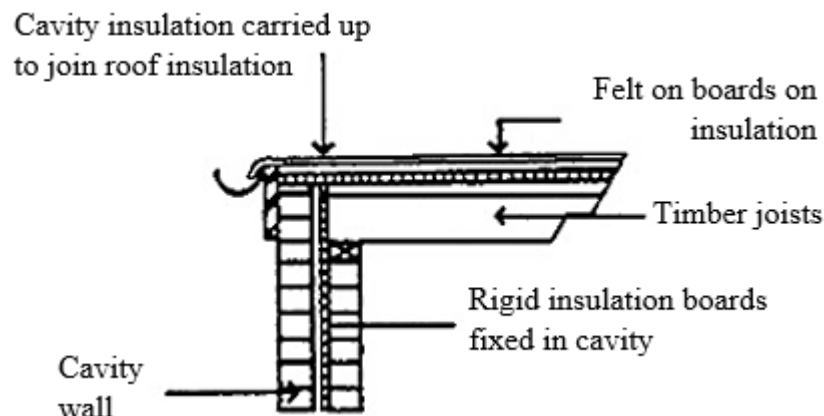

Figure 33. Wall insulation joined to roof insulation (Emmitt & Gorse, 2005)

- **Parapet wall**

In order to make external walls weather resistant, parts which are in direct contact with the environment should be covered with a dense material, which is often stone. The stone should project 50 mm from the edges of the wall. Brick is another material which is suitable to cover parapet wall [Figure 34].

In order to protect the parapet wall against moisture, a horizontal layer is located within it which is called a DPC. The construction detail of DPCs are shown here (Emmitt & Gorse, 2005). [Table 12]

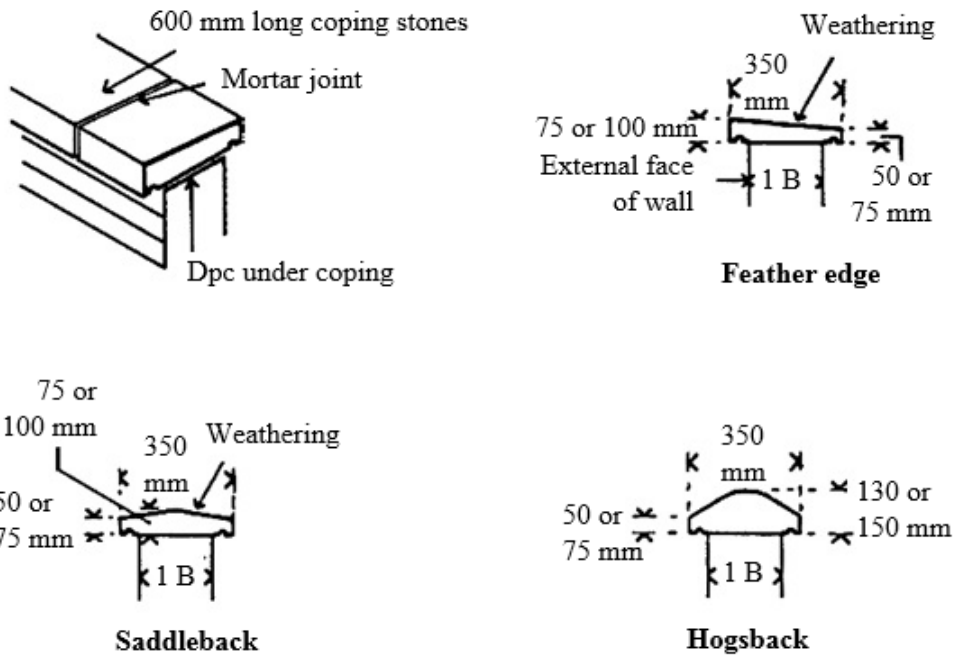

Figure 34. Copping stone (Emmitt & Gorse, 2005)

Table 12. Construction details of different types of DPC (Emmitt & Gorse, 2005)

<p>Solid parapet</p>	
<p>Cavity parapet wall</p>	
<p>Cavity carried above roof</p>	

2.6.2 Pitched Roofs

Most of the pitched roofs have symmetric forms with a central ridge. The structural details of pitched roof were discussed previously in this study. In this part the construction details of pitched roofs will be analyzed.

- **Ventilation**

Ventilators of a pitched roof are gaps in eaves and ridges. The size of ventilation changes for different types of roofs. At least 25mm in the length of eaves is essential. When the slope of a roof is steeper than 35°, 10mm is enough to have proper ventilation. Methods of ventilating pitched roofs are discussed in the indoor air quality and thermal insulation section (Emmitt & Gorse, 2005). [Figure 35]

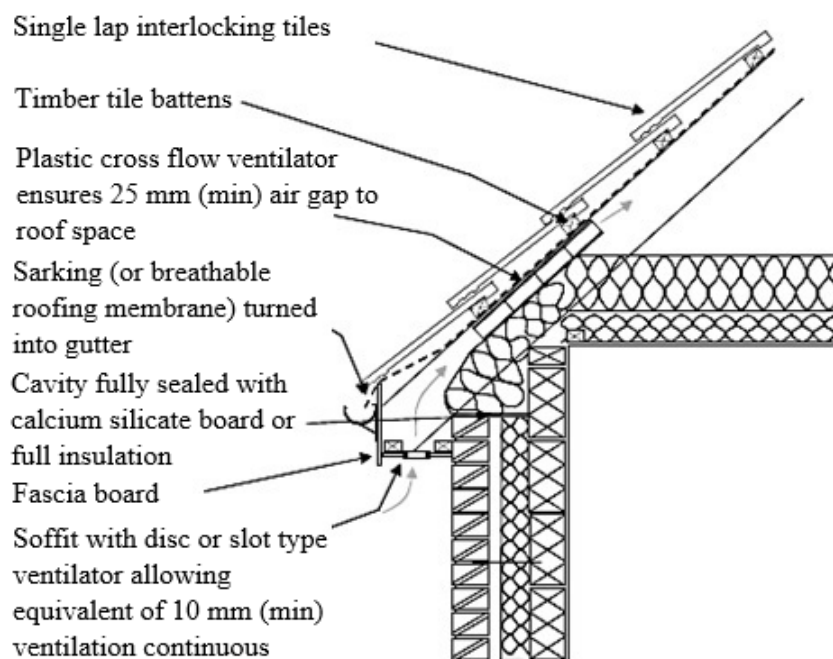

Figure 35. Ventilation of a pitched roof (Emmitt & Gorse, 2005)

- **Dormer Windows**

Dormer windows are vertical openings which allow daylight and air inside and are located over the roof. They may totally or partially project from the roof surface. In

some cases the dormer window may recessed completely behind the roof (Emmitt & Gorse, 2005). [Table 13]

Table 13. Different types of dormer windows (Emmitt & Gorse, 2005)

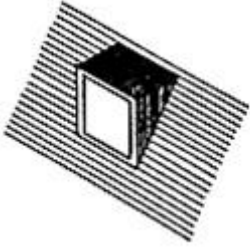
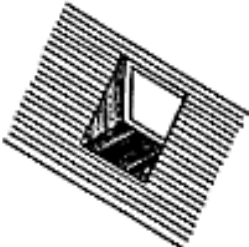
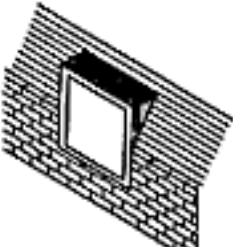
Projecting dormer window	Recessed dormer window	Partly projecting dormer window
		

- **Pitched Roof Coverings**

Various materials can be applied as roof coverings. Some of them are discussed here:

Plain tiles are rectangular units which are produced from burned clays. The slope of a roof which they can cover varies according to the density of the material. The plain tiles which absorb water, can cover roofs with a 45° or higher slopes.

There are three different form of tiles which can cover ridges and according to the desired appearance one of they can be selected. Valleys in a roof which is covered with plain tiles require a lead gutter or a specific type of tiles which are produced to cover those (Emmitt & Gorse, 2005). [Table 14]

Concrete plain tiles are produced by mixing graded sand, cement and water. The mixture is poured into molds and compressed to form concrete plain tiles. There are different forms of concrete plain tiles: Single lap and pantiles which are rounded under and over a tile (Emmitt & Gorse, 2005). [Figure 36, 37]

Table 14. Construction details of plain tiles (Emmitt & Gorse, 2005)

Plain tiling	
<p>Tile and a half width tile in every other course to complete bond</p> <p>265 × 165 mm plain tiles huge double lap with every fourth course nailed</p> <p>Black haired roofing felt fixed across rafters</p> <p>40 × 20 mm battens at 100 mm gauge</p> <p>Rafter</p> <p>Ceiling joists</p> <p>100 × 75 mm wall plate</p> <p>Verge</p> <p>100 mm margin</p> <p>Lap 65</p> <p>180</p> <p>175 × 25 mm fascia</p> <p>Double course at eaves using 180 mm under eaves tiles</p> <p>Cavity wall</p>	
Verge	Ridge
<p>Tile and a half width tile</p> <p>Tiles bedded on wall as undercloak</p> <p>Verge of roof</p> <p>Tiles pointed with mortar</p> <p>Rafter</p>	<p>Half round ridge tiles bedded in mortar and ends solidly filled with mortar for pointing</p> <p>Pointing</p> <p>Ridge board</p> <p>Top course of tiles on 40 × 40 mm battens</p> <p>Plain tiles</p> <p>Roofing felt under battens</p>
Valley tiles	Lead valley gutter
<p>Valley tile</p>	<p>Gutter board</p> <p>Lead gutter</p> <p>Plain tiles</p>

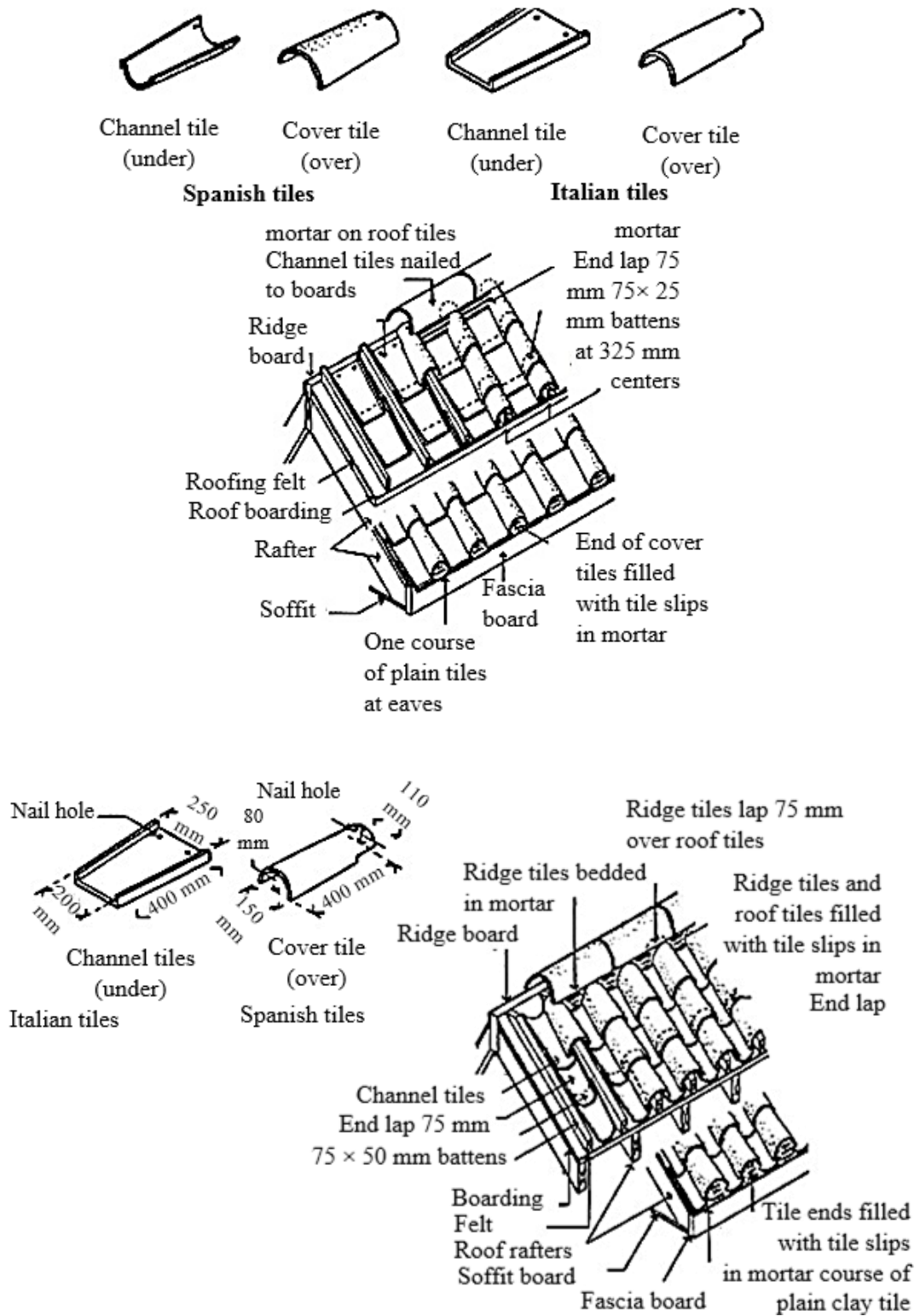

Figure 36. Single lap tiles (Emmitt & Gorse, 2005)

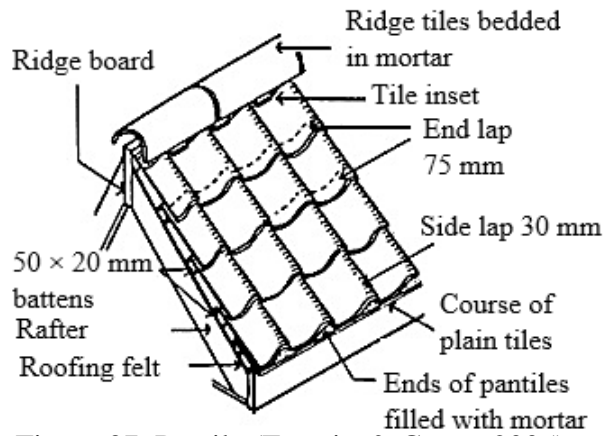
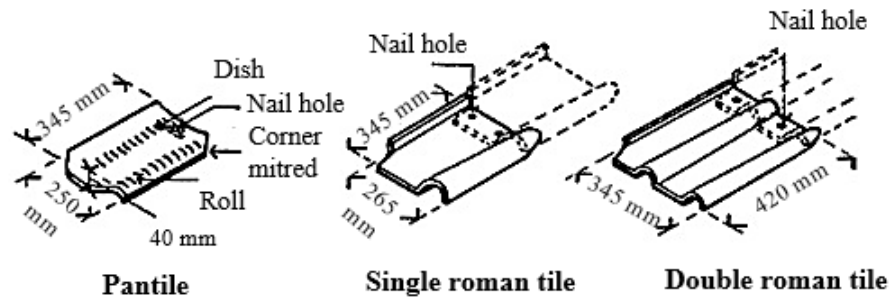
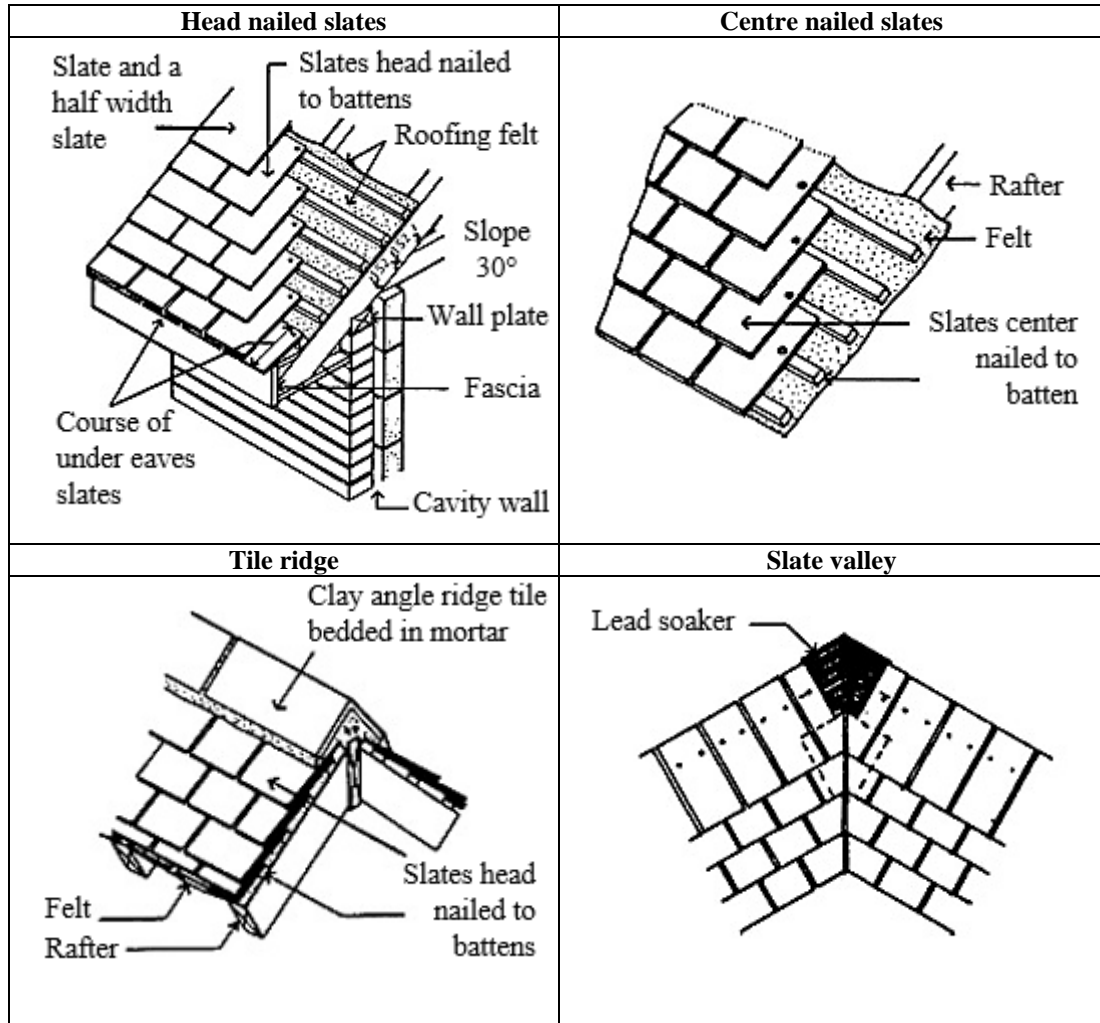

Figure 37. Pantile (Emmitt & Gorse, 2005)

Slates are sheets of natural stone which have been used as a roof covering for a long time especially in regions where they are easy to find and form. The quality of slates differs according to the type, thickness and quality of the stone. Producing new slates is not economically beneficial and in recent years, constructors prefer to use reclaimed slates. The disadvantage of using these materials is that they have different qualities.

It is preferable to cover the ridges (intersection of two slates) with clay ridge tiles. In this case, the material becomes two times thicker in the ridges (Emmitt & Gorse, 2005). [Table 15]

Table 15. Construction details of slates (Emmitt & Gorse, 2005)



Sheet metal covering are suitable for low slope roofs (between 10° to 30°). The main metals which are used to cover roofs are copper and aluminum which have 450 to 600mm width. They are light and do not affect the dead load of the building noticeably (Emmitt & Gorse, 2005). [Table 16]

- **Vapor Barrier**

To prevent moisture movements from inside the building into the cold side of thermal insulation, a layer of vapor barrier (such as polythene) is placed on the inner part of the insulation (Emmitt & Gorse, 2005).

Table 16. Construction details of sheet metal covering (Emmitt & Gorse, 2005)

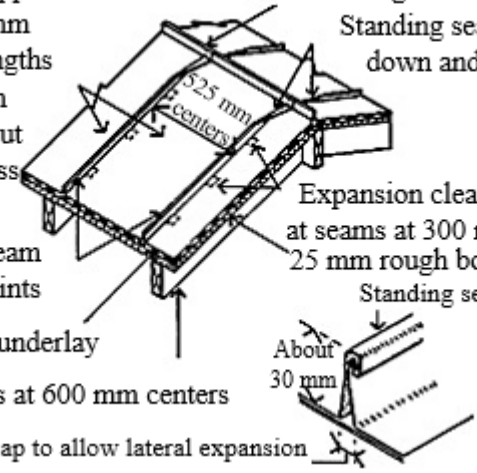
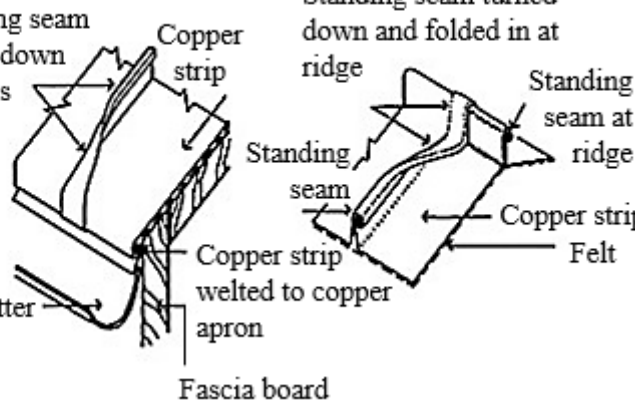
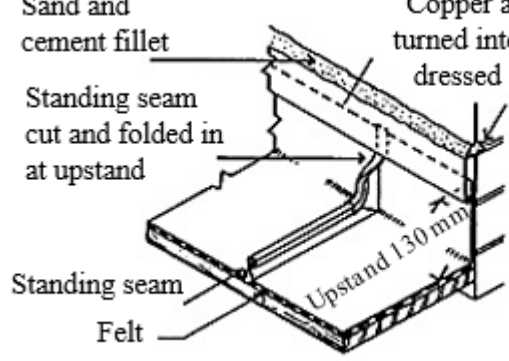
<p>Copper standing seam roofing</p>	<p>0.6 mm copper strip 600 mm wide in lengths up to 8.0 m long without joints across fall</p> <p>Standing seam joints</p> <p>Felt underlay</p> <p>Rafters at 600 mm centers</p> <p>13 mm gap to allow lateral expansion</p> <p>Standing seam at ridge</p> <p>Standing seam turned down and folded in</p> <p>525 mm centers</p> <p>Expansion cleats folded in at seams at 300 mm centers</p> <p>25 mm rough boarding</p> <p>Standing seam</p> <p>About 30 mm</p> 
<p>Eaves and ridge</p>	<p>Standing seam turned down at eaves</p> <p>Copper strip</p> <p>Standing seam turned down and folded in at ridge</p> <p>Standing seam at ridge</p> <p>Copper strip</p> <p>Felt</p> <p>Eaves gutter</p> <p>Copper strip welted to copper apron</p> <p>Fascia board</p> 
<p>Upstand</p>	<p>Sand and cement fillet</p> <p>Standing seam cut and folded in at upstand</p> <p>Standing seam</p> <p>Felt</p> <p>Copper apron welted, turned into groove and dressed over upstand</p> <p>Upstand 130 mm</p> 

2.7 Roofs' Design and Construction Standards

In this section, the existing International Standards related to the roofs' design and construction are studied in order to compare them with contemporary roofs in TRNC. No standards were found for roof construction and design in North Cyprus, thus; International Building Codes and Standards are used for this section.

- **Minimum Slope**

The required minimum slope differs according to the materials which are applied for the roofing membrane. The minimum slope for built-up roofing is %1, however International Building Code suggests at least %2 as applied minimum roof slope. For roofs which terminate into the drains with different slopes and have various up and down point, the shallowest slope should be at least %1 (IBC, 2012).

- **Weather Protection**

Flashing materials must seal roofs' connections with walls, gutters, the points slope or its direction changes and when openings are designed over roofs. The importance of applying flashing is to provide weather resistance and to prevent from moisture movements in the intersections.

When the application of scuppers become necessary, they should be applied in such a form that ponding is prevented. The minimum size of scuppers is 10 cm according to the IBC.

The copings should be covered with a layer of non-combustible material in order to become weather resistant. The width of cover cannot be less than the width of parapet wall (IBC, 2012).

- **Performance requirements**

Rule number 1504 of Building Codes necessitates the constructors to fasten the roofing membrane in such a way that roof's up-lift with wind loads is prevented. In case of low-slope roofs, the materials of these fasteners should be selected in such a way that the roof's integrity during its life cycle is guaranteed. In this respect, roof can resist sun, wind and flexure in high velocity winds (IBC, 2012).

- **Fire resistance**

The International Building Codes have divided buildings into A, B, C and Non Classified classes according to the required level of fire resistance. The minimum fire resistance of roofs changes with the function of the building that it covers (IBC, 2012).

- **Clay and Concrete Tiles**

All clay and concrete tiles which are applied for roofing should be tested for strength and stability. For concrete tiles, also a test of freeze thaw and absorption is needed.

The minimum slope for decks when clay and concrete tiles are applied is %21. However, when the slope is less than %33 an underlayment is also essential. For slopes which are steeper than %33, a layer of interlayment installed shingle is required.

All fasteners which are applied for tile installment should be corrosion protected and a minimum length of penetration of 19.1 millimeters is essential. The method of installing tiles changes according to the climatic conditions, the roofs' slope and the type of tile that is implemented.

All flashings should be corrosion protected and they should be installed in junctures of roofs, vertical layers, or valleys. These flashings should continue for at least 28 cm

on each side of valleys. The width of splash diverter should be 25.4 millimeters. When the slope is steeper than %25 an underlayment is also necessary (IBC, 2012).

- **Built-up Roofs**

As it was mentioned in the previous sections of this thesis, built-up materials are made out of various layers of felt which are cemented together and a layer of aggregate, cap sheet or a similar material which covers them. These materials should be selected in such a way that they work together chemically and mechanically (IBC, 2012).

The minimum slope for built-up roofs is %2 according to the International Building Codes. Only if coal-tar is selected the minimum required slope is %1. In order to find the minimum slope, the shallowest slope in valleys are used (IBC, 2012).

- **Photovoltaic Systems**

The fire resistance of photovoltaic systems is similar to the roof assembly. In addition, the roof's resistance against wind is calculated based on the dimensions of the unit frames (IBC, 2012).

- **Aerial supports**

When the height of aerial supports is not more than 12 inches or 3658 millimeters, combustible materials can be used for their production. However for the aerial and antennas which are more than 3658 millimeters high, non-combustible materials must be used (IBC, 2012).

- **Dormers**

Roofs' dormers should be constructed with similar techniques with the roofs or the exterior walls (IBC, 2012).

- **Ventilation**

When enclosed attics are applied (attics with ceiling directly beneath them), separate cross ventilation is essential for each space. The openings for cross ventilation should be applied in such a way that they resist rain and snow.

This ventilation should not be interfered. The minimum air space is 25 mm and is located between sheeting and insulation according to the International Building Codes. The ventilation area should not be less than 1/150 area of the space which is ventilated (IBC, 2012).

- **Air barrier**

All external building elements should be designed and constructed with a layer of air barrier. This layer must be continuous throughout all building envelope and should be identified clearly during the design stages. Design details of interconnections and joints with this air barrier are essential. The air barrier layer must cover all the building layers which are in contact with the surrounding environment such as external walls, roof, ceiling and lowest floors. This layer should also resist the imposed loads (ASHRAE, 2012).

- **Thermal Insulation**

According to a categorization in ASHRAE, Cyprus is categorized under the 3rd climate classifications. All building which are located in the 3rd category of climates according to ASHRAE must have at least a three-year-aged solar reflectance, a three-year-aged thermal emittance or an increased insulation level (ASHRAE, 2012).

For climate number 3, if the insulation is located entirely above deck, for non-residential and residential buildings, minimum R-Value is R-20.0 c.i. for roofs. While

for semi-heated buildings, it becomes R-5.0c.i. For metal buildings, R13.0+R13.0 in residential and non-residential buildings and R-10.0 in semi-heated ones. Finally in buildings with attics and others, at least R-38.0 for residential and non-residential buildings and R-19.0 for semi-heated ones is essential according to ASHRAE (ASHRAE, 2012).

The thermal insulations of the exterior layers of buildings should be protected with a material against sunlight, moisture, landscaping operations, equipment maintenance, and wind (ICC, 2009).

Thermal insulation should not be located on suspend ceilings which have movable ceiling pads (ASHRAE, 2012).

A research which is conducted by Özdeniz and Hançer have proven that the roofs which have thermal insulation showed better performance compared to the one which are constructed with no thermal insulations in North Cyprus (Özdeniz & Hançer, 2005).

Furthermore, the study has demonstrated that, when the layer of thermal insulation is towards the inner layers of the roof, its performance increases. Standing roofs have shown better performance because they protect ceiling against direct solar radiations and heat. However a permanent layer of ventilation is essential for standing roofs.

Flat roofs are required to have light reflectance beside thermal insulation. The application of thermal insulations prevents condensation, however; ventilation becomes essential in these cases (Özdeniz & Hançer, 2005).

- **Moisture control**

All walls, floors, roofs and the elements of thermal envelope should be covered with a layer of thermal retarder according to the International Residential

Code. The position of this layer is in such a way that it is towards the warmer side of thermal insulation in winter.

The only exception of applying vapor retarder layer is when the material does not change with moisture or when these spaces are permanently ventilated and the moisture is dried out (IRC, 2012).

- **Drainage**

The factors which affect drainage of roof are the roofs' slope, sizes of drains, and their positions. The size of drains should be considered in such a way that water enters drains with a proper speed. At least 2 drains are essential, however; the number of drains must be calculated according to the roofs' area and the amount of rainfalls in the related climate. Minimum size of drain pipes is 3 inches (IBC, 2012).

It is preferred that the distance between drains is not less than 15 meters, while; the distance with roof perimeter shall not exceed 30.5 meters.

Pipe fittings should be selected in accordance with the piping materials. All roof drains should be covered with strainers and the distance between strainers and the roof level shall not exceed 102 mm. The size of gutters is calculated according to the climate in which the roof is constructed, the slope of roof, length of gutters, and the roofs' area (IBC, 2012).

All roof drains can terminate into a separate sewer system or a combined one to drain water. For small-sized buildings, the rainwater can be transferred to external flat spaces like streets. If the sewer is designed only for sewage, rainwater should not be drained by using them.

Size of pipes cannot decrease in the direction of the drains and roofs should be designed in accordance with the maximum depth of the ponding water (IBC, 2012).

- **Drainage fittings**

All pipe fittings should be selected according to the existing standards. No edges, shoulders or anything that decreases the speed of water drain is allowed for the fittings of the drain pipes (IBC, 2012).

All drains must be covered with strainers which extend for at least 102 millimeters from each side. An inlet area which is located over the roofing layer is essential in this case (IBC, 2012).

The intersection of roof with drain should be completely water tight. For this aim, the materials which are suitable for flashing can be selected. The size of drains is calculated according to the 100 years of hourly rainfall rate (IBC, 2012).

Chapter 3

FINDINGS AND DISCUSSIONS

3.1 Evaluation Criteria for Roof Defects in North Cyprus

This chapter discusses the gathered data and analyzes them. The main aim of this part is to give an image of roof construction in Northern Cyprus and to find the related problems. The first section, after introduction, introduces the case for this thesis and the construction industry in TRNC. The third section of this chapter, discusses the collected data to give an image of roof construction in TRNC. Similar to the literature review, this section is also divided into five different parts which are form, structure, indoor air quality and thermal insulation, material and construction details. Then, roof defects according to the owners, constructors, designed projects, observations and discussions will be presented and compared.

Roof forms are studied in Google Earth maps and the percentage of the application of flat and pitched roofs is compared. Then, the structure of roofs is being asked from the architects, civil engineers and constructors of the selected 20 construction companies. The process of studying the roofs' materials, construction details and indoor air quality and thermal insulation continues by analyzing the selected 15 projects. The selected projects are then analyzed to find roof problems which originate from the designing process.

The next stage of data collection studies roof problems according to the owners (5-6 years after occupation). For this reason, the number of constructed units in 2009 in the case are selected as base to calculate the sample size. According to Devlet Planlama Örgütü in 2009, 2064 buildings are constructed in Nicosia, Famagusta, Kyrenia and Iskele districts. 326 buildings are selected and the owners are asked to fill questionnaires. 96 of the respondents are in Nicosia, 53 in Famagusta, 139 in Kyrenia and 38 in Iskele.

The constructors are also asked about roof defects in North Cyprus. 20 different firms are selected and the respondents are asked to fill questionnaires. Finally, photography and observation are utilized to demonstrate roof problems.

3.1.1 Selection of the Case Area

Cyprus is located in east of the Mediterranean Sea and it is the third largest Island. North Cyprus is divided into five districts: Nicosia, Kyrenia, Famagusta, Iskele and Güzelyurt. Nicosia, Kyrenia, Famagusta and Iskele districts are selected as cases for this thesis. Nicosia is the capital of Northern Cyprus and has %33.1 of the population of the country. Kyrenia is situated in the northern coast of Cyprus with %25 of the Island's population. Famagusta has the major port of TRNC with %23.7 of the population, while; Iskele is located in the northeast of Cyprus and it is one of the most beautiful districts of the country with %7.8 of its population (Devlet Planlama Örgütü, 2011). [Figure 38]

Construction in TRNC during the last century can be divided into different periods. Local materials (wood, soil, clay tiles and bush branches) were commonly used during the first years of the century. First change in the construction industry during last

century occurred between 1960 to 1985. Industrial materials such as brick and reinforced concrete became popular which led to constructing cheap buildings. From 1960, and with the development of the tourism industry, new styles and ideas entered the country without considering traditional values (Florides et al., 2001).

On the other hand, Annan Plan had a great impact on the construction in TRNC. Annan Plan caused a noticeable investment in the real estate and a boom in all sectors of construction industry in Northern Cyprus. Especially Famagusta and Kyrenia, faced significant development during 1960s (Yorucu & Keles, 2007).

After 1985 applying insulations became more popular and construction began to cost more. Contemporary roofs are generally flat, with 15 cm thickness. Reinforced structures are common, most of the roofs are built without any thermal insulations. This type of construction is cheap, however; results in great problems. This technique is similar in all cities in North Cyprus and is often applied because it requires no special skills (Florides et al., 2001). [Figure 39, 40]

In recent years, the construction industry in TRNC has faced a stagnation. A number of buildings which are built during the construction boom remain empty without any owners (Anon, 2013). On the other hand this method of cheap construction has resulted in dissatisfaction of the users.



Figure 38. North Cyprus (URL 1)



Figure 39 and 40. Construction in North Cyprus (URL 2, 3)

3.2 Analysis of Roof Forms in North Cyprus

In order to give an image of roof forms in North Cyprus, it is studied in the four districts which are cases of this thesis. The following figures demonstrate the percentage of flat and pitched roofs in rural and urban parts of Nicosia, Famagusta, Kyrenia and Iskele districts. The last column of each figure shows the percentage for the urban parts of these districts.

More developed villages are observed to have more flat roofs. In the core of every village in Nicosia district, gabled and hipped roofs are often observed. Close to the edges of these villages, which are recent developments, flat roofs are often applied. In larger villages, such as Dikmen (%60 flat and %40 pitched) and Gönyeli (%57 flat and %43 pitched) flat roofs are more popular than the pitched ones. Similar results were observed in the urban parts of Nicosia district. [Figure 41]

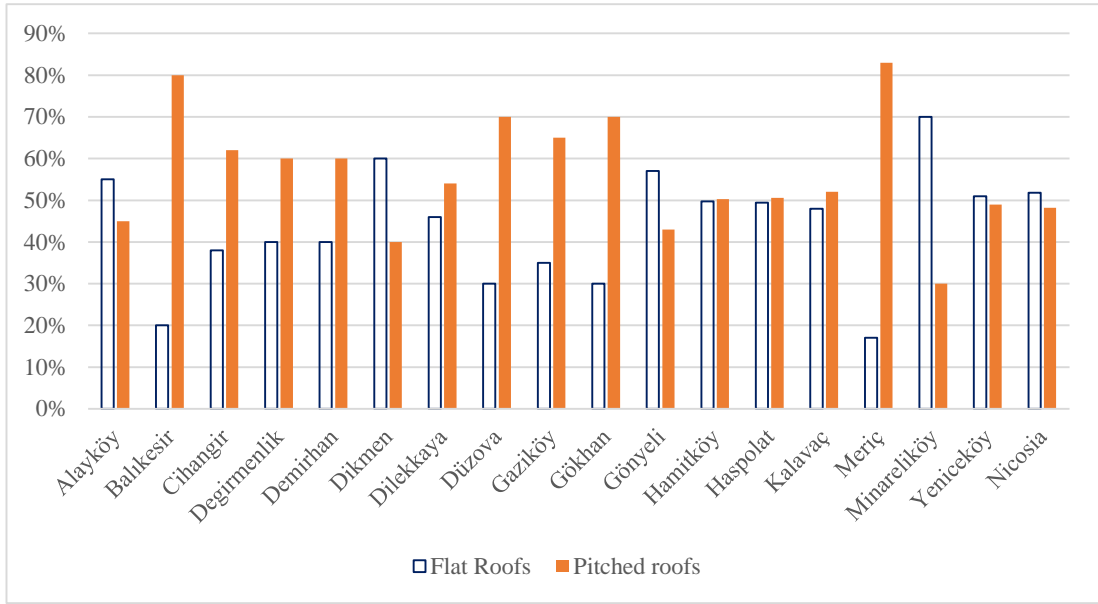

Figure 41. The percentage of flat and pitched roofs in some of the rural and urban parts of Nicosia district (Google earth, 2014d)

Figure 42 compares the percentage of flat and pitched roofs for Famagusta district. As it is demonstrated in the figure, in urban parts of Famagusta, flat roofs are commonly observed (%70 flat and %30 pitched); while in villages, pitched roofs are often applied. Pitched roofs are mostly in the edges of the city. Middle-rise buildings are mostly constructed with flat roofs. [Figure 42]

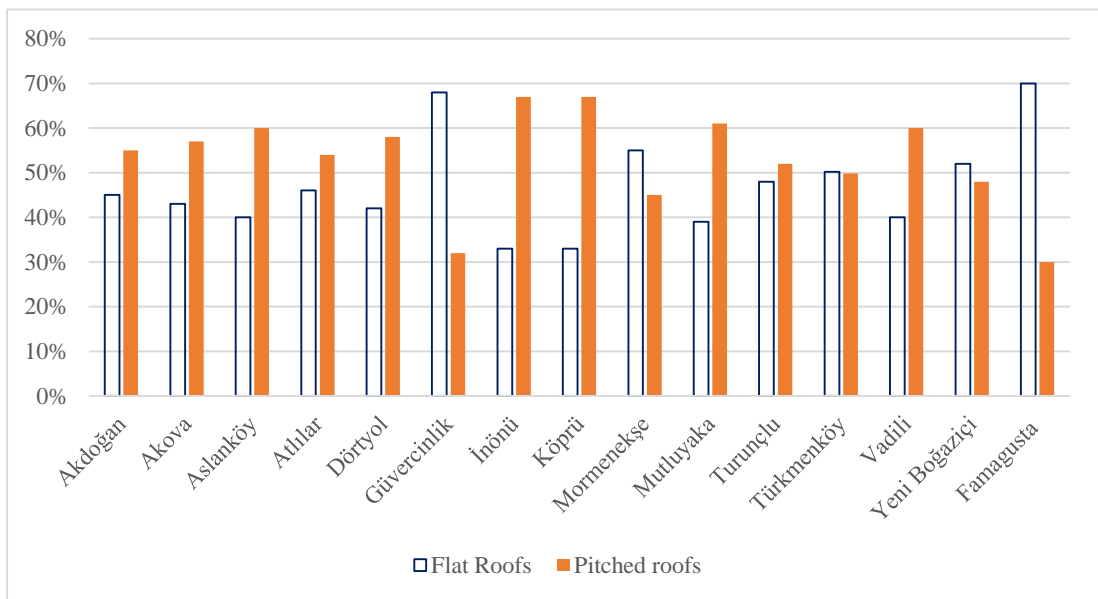

Figure 42. The percentage of flat and pitched roofs in some of the rural and urban parts of Famagusta district (Google earth, 2014c)

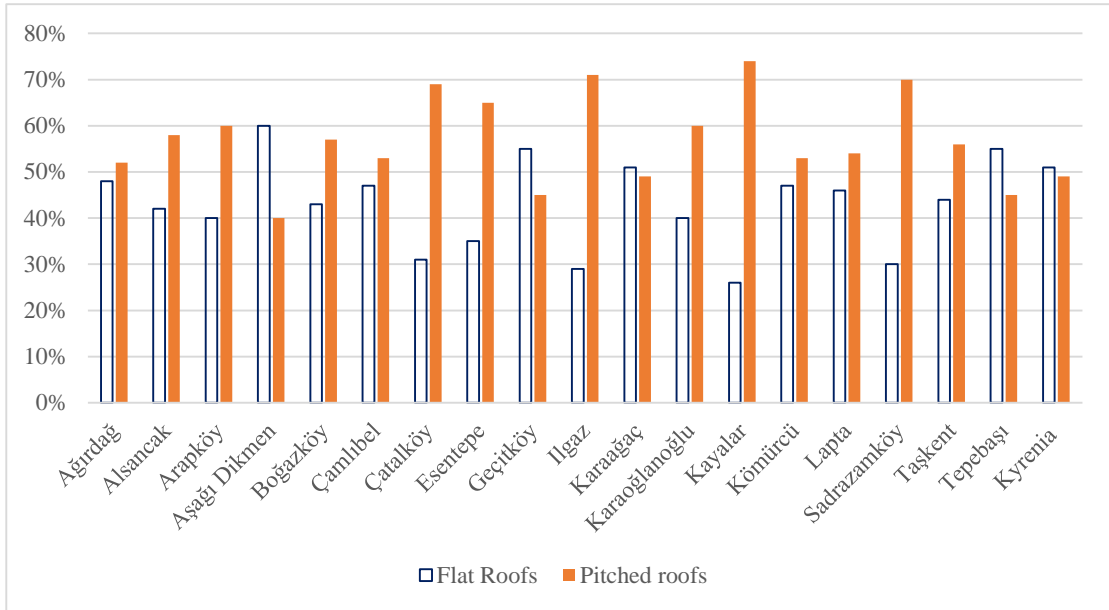

Figure 43. The percentage of flat and pitched roofs in some of the rural and urban parts of Kyrenia district (Google earth, 2014b)

Similarly, figure 43 compares form of the roofs in the Kyrenia district. A slight difference is observed between flat and pitched roofs in the urban parts of Kyrenia. However, this difference increases in the rural parts to the point that it reaches to %69 pitched and %31 in Çatalköy, %71 pitched and %29 flat in İlgaz. [Figure 43]

Finally, figure 44 analyzes roof forms in İskele. In contrast to what is observed in Kyrenia, less flat roofs are observed in the urban parts (especially in the edges of the city); in the villages flat roofs are mostly applied. The difference reaches to its highest level in Bafra, Görneç and Ziyamet. [Figure 44]

Dome forms are rarely chosen for some religious buildings. However, because they are rarely implemented, dome forms are not mentioned in these figures.

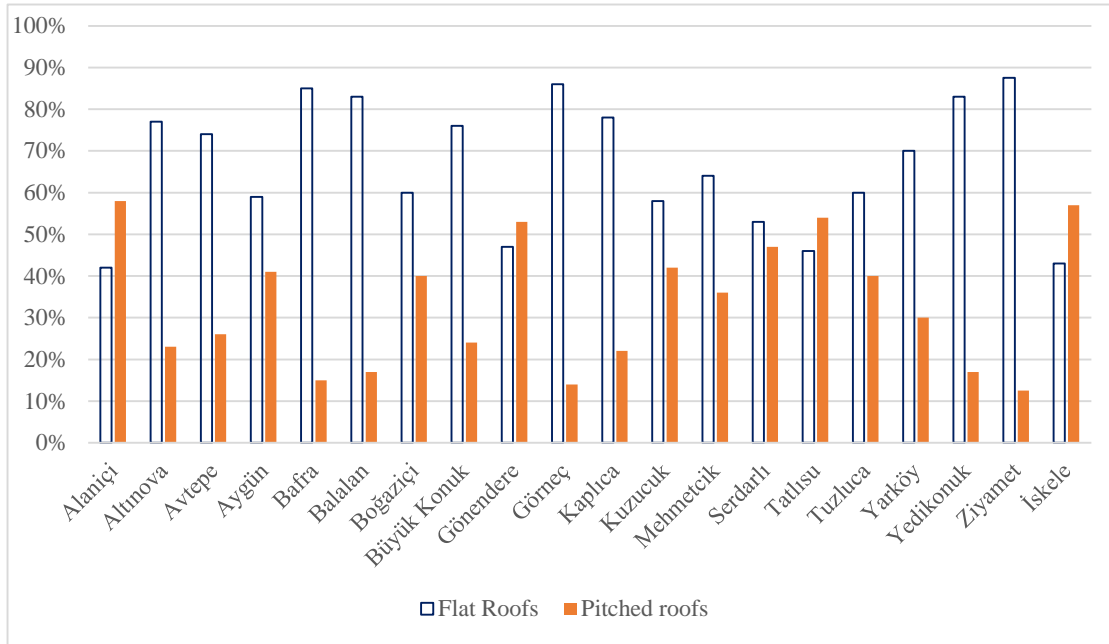

Figure 44. The percentage of flat and pitched roofs in some of the rural and urban parts of Iskele district (Google earth, 2014a)

3.3 Analysis of Roof Structures in North Cyprus

The percentages of the application of each roof structure are asked from the constructors. Five different structures which are common in North Cyprus are given to the respondents and they are asked to point from 1 to 100 to each of them according to their popularity in North Cyprus in a way that the sum of points becomes 100. The average of results is shown in the following figure. [Figure 45]

As it is obvious from the figure, reinforced concrete is the most popular structural material which is selected both for flat roofs and the pitched ones. Especially flat reinforced concrete structures are highly applied in Famagusta. Another structure for pitched roofs is standing timber roof (commonly in Iskele). Steel structures are rarely selected and they are mostly built in form of pitched roofs.

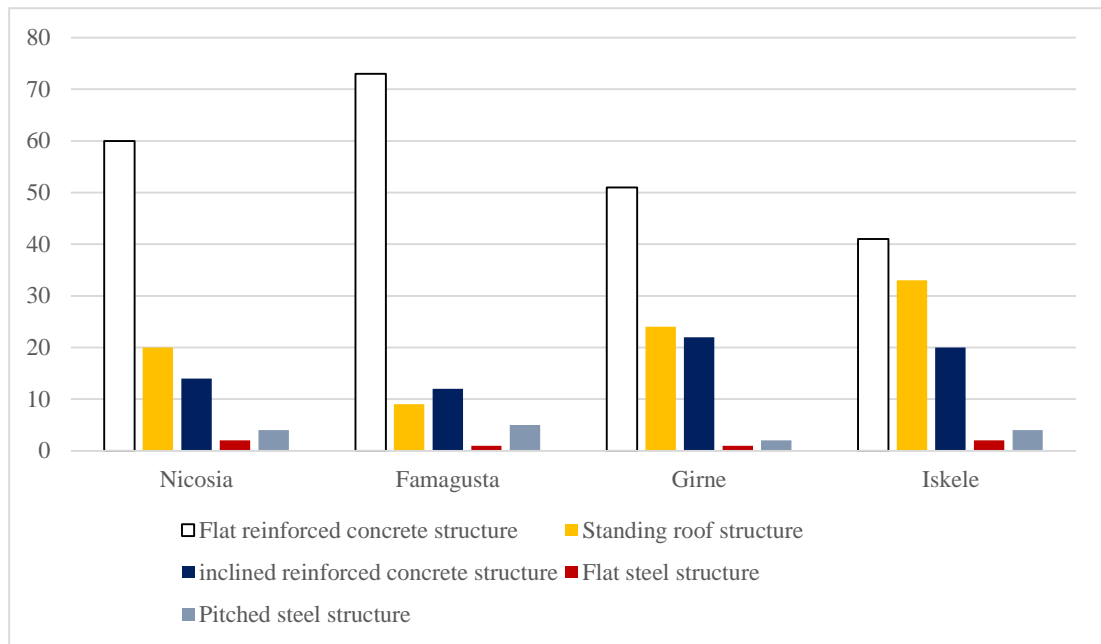

Figure 45. The percentage of application of different roof structures in North Cyprus

3.4 Analysis of Roof Materials in North Cyprus

In this stage, 15 different projects which are designed and built in North Cyprus are analyzed. [Figure 46 to 60] The selected material are shown in the following table. [Table 17]

The structural material for most of these projects is reinforced concrete. The implementation of timber and steel is observed in some cases. Only in 5 project of the analyzed projects thermal insulation is being applied. Polyester is the common material; while, glass wool is also used in some cases (project number 7). Sandwich panels are also performing as thermal insulators in the steel roofs.

Bituminous is the common waterproofing material. Polyester felt and bituminous are working as roofing membrane for flat roofs. Clay tiles are selected for the pitched roofs. In three of these projects Marseille tiles are designed to be implemented.

Galvanized steel is the material of the roofs' gutter for most of the analyzed pitched roofs. Plastic drain pipes are also popular among the constructors. In one case (project number 3), gutter is made out of reinforced concrete and is built along the roof. In project number 8 and number 10, pvc gutters and drain pipes are used.

Table 17. Analysis of roof materials in North Cyprus

Roof Materials in the Analyzed Projects (Figures number ...)	
Project No.1	Reinforced concrete, Romanian timber, bituminous, chipboard, clay tiles, gypsum plaster, plastic, galvanized steel
Project No.2	Reinforce concrete, polyester felt, bituminous waterproofing, gypsum plaster, plastic pipe
Project No.3	Reinforced concrete, polystyrene thermal insulation, clay tile, timber, bituminous waterproofing, gypsum plaster
Project No.4	Reinforced concrete, clay tile, Romanian timber, chipboard, polystyrene thermal insulation, bituminous waterproofing, gypsum plaster, plastic
Project No.5	Reinforced concrete, polyester felt, bituminous waterproofing, gypsum plaster
Project No.6	Reinforced concrete, bituminous, polystyrene felt, leveling concrete, protective concrete, gypsum plaster
Project No.7	Reinforced concrete, timber, polystyrene heat insulation, glass wool insulation, waterproof chipboard, Marseille tiles, gypsum plaster
Project No.8	Steel beam, galvanized profile, sandwich panel, pvc
Project No.9	Corrugated steel sheet, steel box profile
Project No.10	Steel truss, steel box profiles, sandwich panel, pvc gutter and pipes
Project No.11	Reinforced concrete, Romanian timber, clay tile, chipboard, bituminous waterproofing, gypsum plaster
Project No.12	Reinforced concrete, Romanian timber, chipboard, bituminous, vapor retarder, clay tile, terrazzo, gypsum plaster
Project No.13	Timber, blanket type water insulation, Marseille tiles, plastic pipes
Project No.14	Romanian timber, chipboard, clay tile, bituminous waterproofing
Project No.15	Timber, Marseille tiles, blanket type waterproofing

3.5 Analysis of Roofs' Indoor Air Quality and Thermal Insulation in North Cyprus

The construction details of the selected 15 projects are shown in table 18 and 19. Most of these buildings are constructed without any thermal insulations. In order to decrease

costs, a great amount of contemporary buildings are built without thermal insulations in North Cyprus.

The position of thermal insulation is different in these projects. In some cases it is located under the protective layer and roofing membrane, while sometimes it is located on the reinforced concrete slab of a pitched roof or the inclined timber (in project number 7 both slab and inclined rafter are insulated).

Reinforced concrete which is often used as a structural material has a good resistance against fire and it does not rapidly lose its strength when temperature rises. Corrosion occurs when metals are located alongside each other. Metal materials are rarely selected for construction in North Cyprus.

3.6 Analysis of Roof Construction Details in North Cyprus

The construction details of 15 projects are in the table 18 and table 19. It can be concluded from the tables that, in most of the cases, the construction details are similar when roofs are built with same structure and form. There are not a wide variety of materials in these details.

Flat roofs are mostly constructed with reinforced concrete structure. Leveling concrete creates the required slope and bituminous performs as waterproofing. In some cases thermal insulation is located beneath the roofing layer.

Pitched roofs with reinforced concrete, are mostly observed in cases where a combination of pitched and flat reinforced concrete are applied. In the project number 3, which is a sample of this method of construction, the thermal insulation is situated beneath the lath.

Samples of the application of timber and reinforced concrete slabs are projects number 1, 4, 7 and 11. The details are similar and only a slight difference exists between them. Tile laths are located beneath tiles and bitumen performs as waterproofing. Chipboard and rafter are beneath the waterproofing layer. Also, in some cases (for example project number 7) a layer of thermal insulation is applied to both the reinforced concrete slab and the inclined rafter. In some other cases (like project number 1) no thermal insulation is applied which increases the risk of condensation.

Roofs number 8, 9, 10 are samples of steel roof structures. These details are covered with sandwich panels which also acts as insulation. For example in the project number 8, galvanized profile is used and sandwich panel is situated beneath it. Steel beams are supporting the roof. Project number 9 is a store building which demonstrates a sample of steel truss construction in North Cyprus. This truss is built with box profiles. The last three projects are showing the roofs which are constructed with timber rafters. Blanket type waterproofing is applied beneath tiles or the lath in these cases.

Table 18. Analysis of roof details in North Cyprus

Roof Details in the Analyzed Projects (Figures number 52 to 59)		
Standing roof (Project No.1)	Flat reinforced concrete roof (Project No.2)	Flat reinforced concrete roof (Project No.3)
 <ul style="list-style-type: none"> -CLAY TILE -TILE LATH (2x1 ROMANIAN) -BITUMINUS WATER INSULATION -0,8mm Chipboard -4x2 RAFTER -RC SLAB 17 CM -PLASTER 0.5 CM -PLS. PAINTING 	 <ul style="list-style-type: none"> -Waterproofing, polyester felt bituminous -Leveling concrete, 4-6 cm -Reinforced concrete slab, 15 cm -Plaster + painting, 2cm 	 <ul style="list-style-type: none"> Protective layers Polystyrene thermal insulation Bituminous waterproofing Leveling concrete Reinforced concrete slab 15cm Plaster+painting
Inclined reinforced concrete roof (Project No.3)	Standing roof (Project No.4)	Flat reinforced concrete roof (Project No.5)
 <ul style="list-style-type: none"> -Clay tiles -Tile lath (2.5 x 5 cm.) -Polystyrene thermal insulation -Bituminous water insulation -Leveling concrete -Reinforced concrete 	 <ul style="list-style-type: none"> -TILE -TILE LATH (2x1 ROMANIAN) -POLYSTYRENE THERMAL INSULATION -BITUMINUS WATER INSULATION -0,8mm CHIPBOARD -4x2 RAFTER -REINFORCED CONCRETE SLAB 17 CM -PLASTER 0.5 CM -PLS. PAINTING 	 <ul style="list-style-type: none"> -Waterproofing, polyester felt bituminous -Reinforced concrete slab, 15 cm -Plaster + painting, 2cm
Flat reinforced concrete roof (Project No.6)	Standing roof (Project No.7)	Steel roof (Project No.8)
 <ul style="list-style-type: none"> -Protective concrete, 2 cm -Separating layer, Felt 0.5 cm -Waterproofing, polyester felt bituminous cover, 0.5 cm -Leveling concrete, 5 cm, %1 -Reinforced concrete slab, 17 cm -Plaster + painting, 2cm 	 <ul style="list-style-type: none"> Marseille tiles Tile lath (2.5x2.5cm) Polystyrene heat insulation Waterproof chipboard Rafter (6x12 cm) Glass wool heat insulation Reinforced concrete slab Plaster + painting 	 <ul style="list-style-type: none"> Ceiling profile (210mm) Sandwich panel Galvanized steel beam (6x15 cm) Hexagonal gater Drainer Pre. outwaterpipe (Ø 5.5cm) Three sand return plating plates

Table 19. Analysis of roof details in North Cyprus

Roof Details in the Analyzed Projects (Figures number 60 to 66)		
Truss steel roof (Project No.9)	Steel roof (Project No.10)	Standing roof (Project No.11)
 <ul style="list-style-type: none"> -Corrugated steel sheet -Top flange 80x80 -Te bar 60x60 -Bottom flange 80x80 40x40 BOX PROFILE 80x80 BOX PROFILE 	 <ul style="list-style-type: none"> -Sandwich panel -Box profile (4x10) -Wind bracing element -Box profile (4x10) -Truss (5x10) Pvc rainwater gutter Drainer Pvc rainwater pipe Ø 7.5cm 	 <ul style="list-style-type: none"> -TILE -TILE LATH (2x1 ROMANIAN) -BITUMINOUS WATERPROOFING -0.8mm CHIPBOARD -4x2 RAFTER -RC SLAB 17 CM -PLASTER 0.5 CM PLS. PAINTING
Inclined reinforced concrete roof (Project No.12)	Flat reinforced concrete roof (Project No.12)	Pitched timber roof (Project No.13)
 <ul style="list-style-type: none"> Clay tile Tile lath Bituminous waterproofing Reinforced concrete Plaster 	 <ul style="list-style-type: none"> Terrazzo Timber lath Bituminous waterproofing Reinforced concrete slab Plaster 	 <ul style="list-style-type: none"> Marseille tiles Blanket type water insulation Lath 2x2 Rafter 5/15
Pitched timber roof (Project No.14)		Pitched timber roof (Project No.15)
 <ul style="list-style-type: none"> -TILE -TILE LATH (2x1 ROMANIAN) -BITUMINOUS WATERPROOFING -0.8mm CHIPBOARD -4x2 RAFTER 		 <ul style="list-style-type: none"> Marseille tiles Timber lath 2x2 blanket type waterproofing Rafter 5/15

3.7 Evaluation of Roofs According to the Owners

The next stage of collecting data was to study owners 5-6 years after occupation. The level of satisfaction and materials which they prefer for roofs are asked from the participants. For the first question, %1.2 of the respondents did not answer the question. The results of t-test demonstrated that the question is randomly missed. %52.1 of the respondents were unsatisfied with the roof of the occupied building, %37.1 were satisfied and %9.6 neutr. The following figure illustrates that most of the users are not satisfied with roof systems in North Cyprus. [Figure 46]

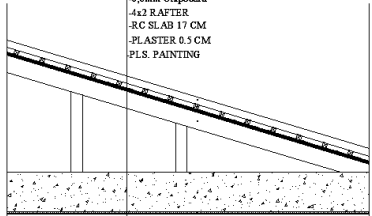
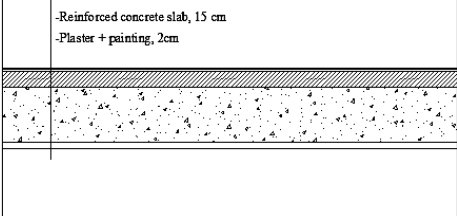
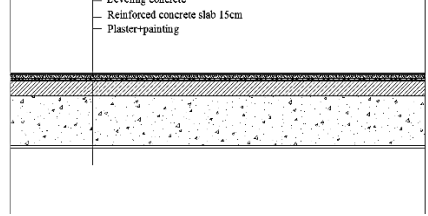
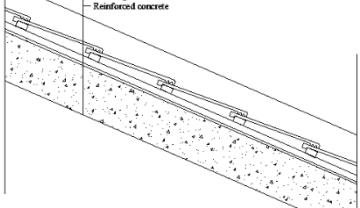
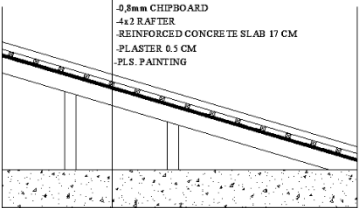
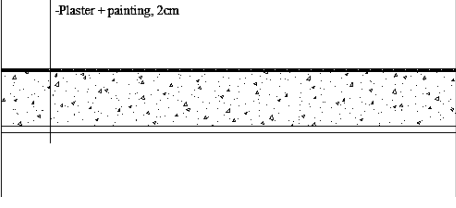
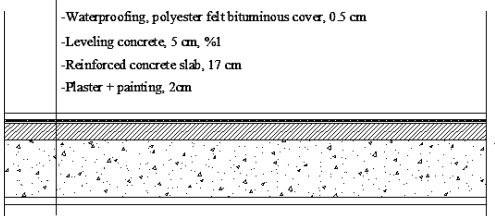
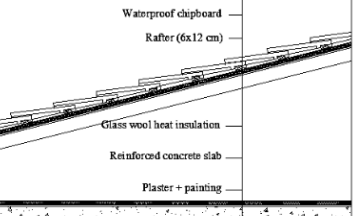
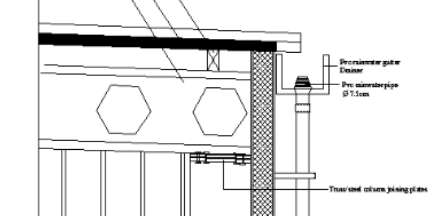
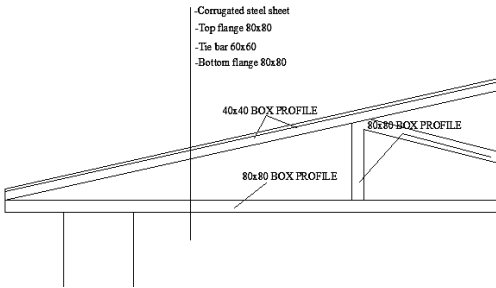
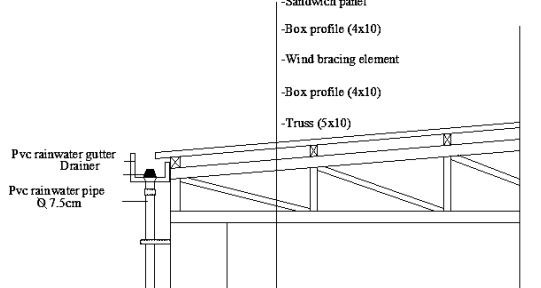
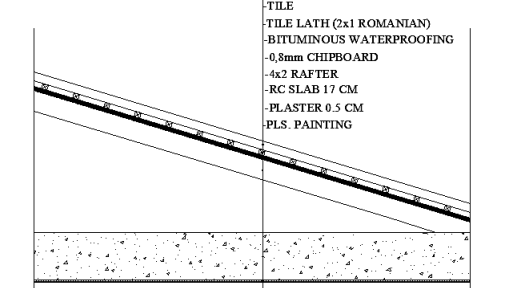
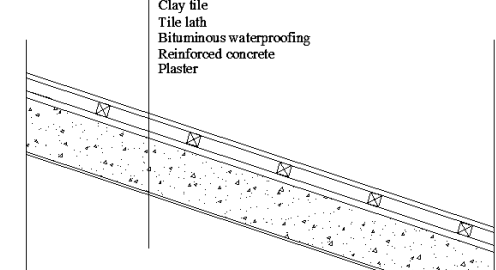
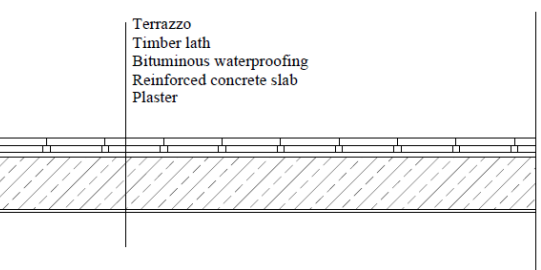
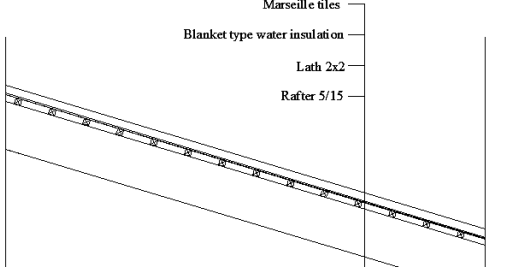
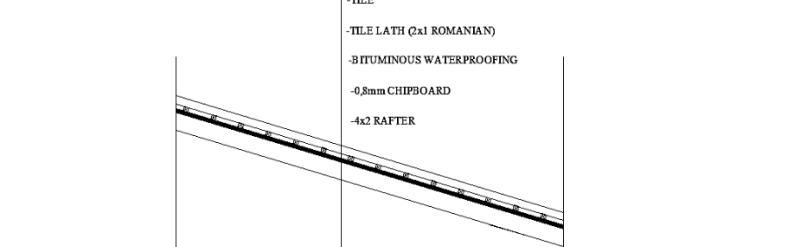
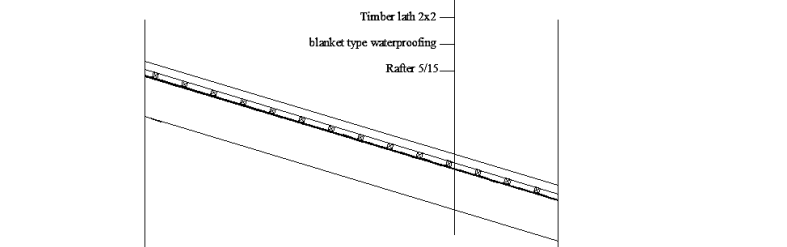
The second figure shows that reinforced concrete is the most preferred material for roof structure. High application of reinforced concrete in North Cyprus may be the reason of choosing this material. Timber, %27.6, is the second selected material, while; precast concrete and metal are rarely chosen. [Figure 47]

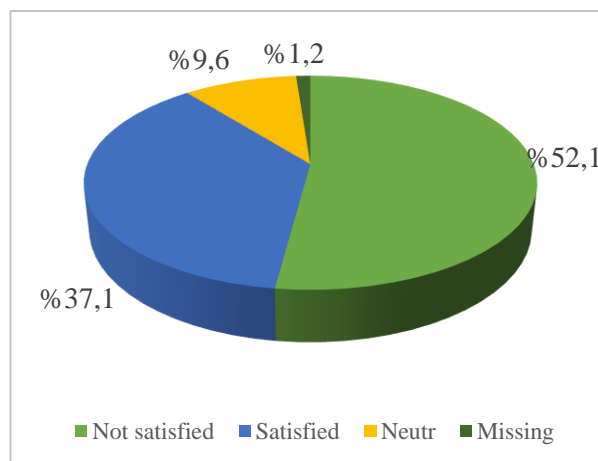

Figure 46. The level of satisfaction of the owners

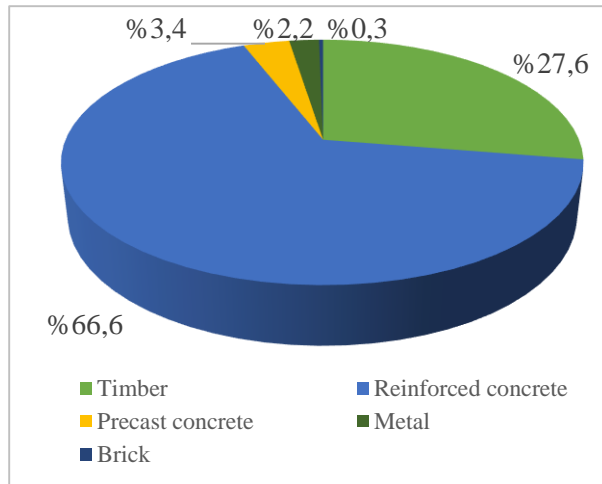

Figure 47. The preferred material for roof structure according to the owners

The next step of studying owners was to find the roof forms which they prefer. Images of some common roof forms are shown to the owners and they are asked to choose maximum three of them. The results are shown in the following figure. Hipped roof (%28.8) is the most popular form, while duo-pitched roof is the second one (%20.5).

Another popular roof form is found to be the pavilion roof (%16.3). The results demonstrated that flat roofs are rarely chosen (%5.7). [Figure 48]

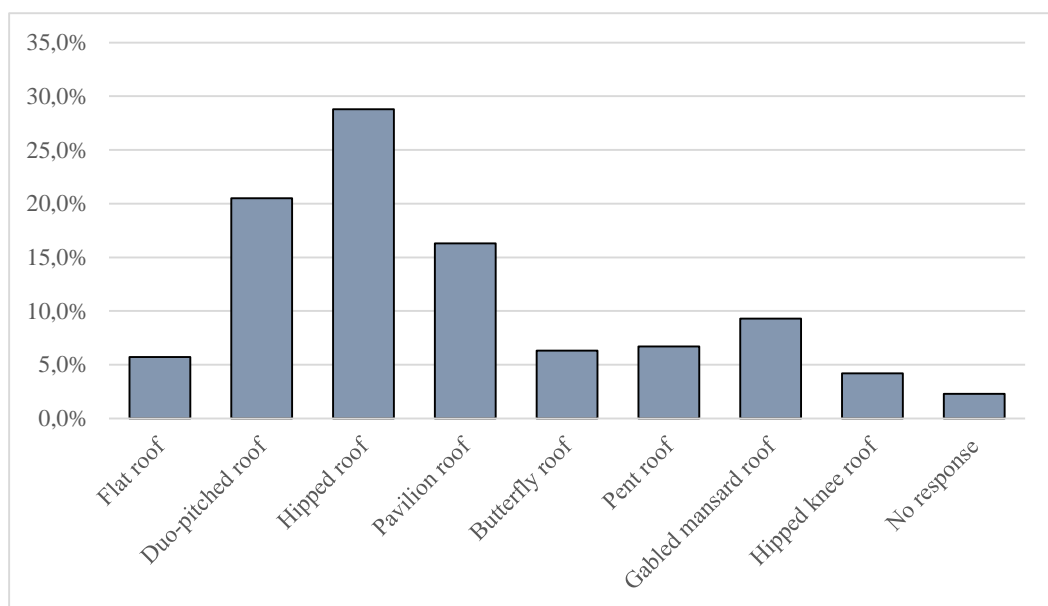

Figure 48. Preferred roof forms according to the owners in TRNC

3.8 Evaluation of Roofs According to the Constructors

Roofs are evaluated by constructors in this step. First, the level of satisfaction and the preferred roof types are asked from the constructors. Most of the constructors were satisfied with the current roof systems in North Cyprus (%65). However, %20 of the constructors were not satisfied and %15 have selected neutr. [Figure 49]

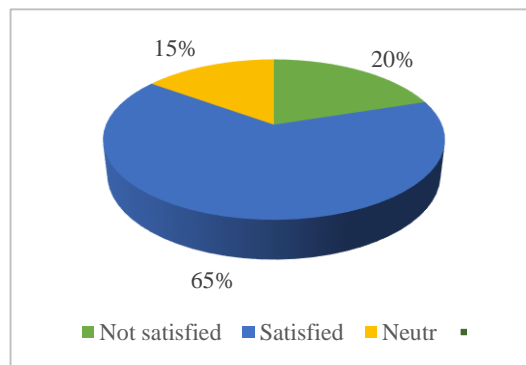

Figure 49. The level of satisfaction of the constructors

Figure 50 illustrates the preferred roof types according to the constructors. %50 of them prefer flat reinforced concrete roof, %15 have selected pitched reinforced concrete roofs. Standing timber is selected by %30 of the respondents. It is clear from the results that they are hesitate to implement other roof types. [Figure 50]

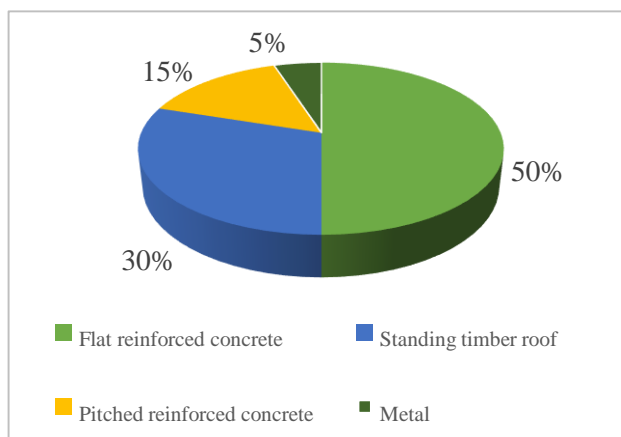

Figure 50. Preferred roof types according to the constructors

Figure 51 shows that %80 of the constructors believe that flat reinforced concrete roofs are popular today, while; %15 claim that standing timber roofs are popular. Only %5 have selected pitched reinforced concrete roofs as the most popular roof types. [Figure 51]

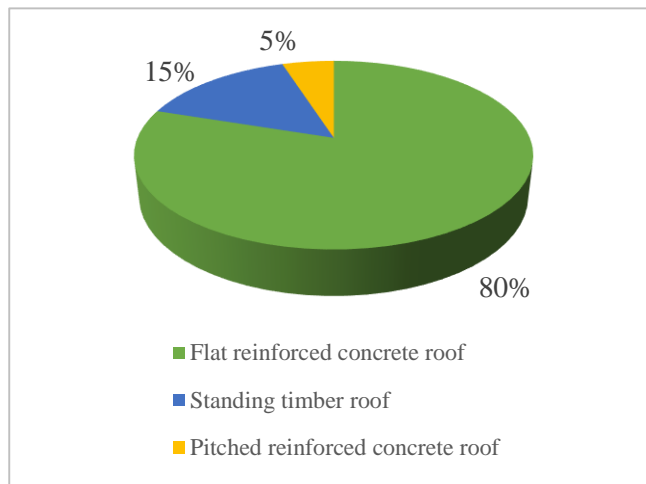

Figure 51. Popular roof types today

3.9 Findings on the Roof Defects According to the Designed Projects

In order to find roof problems which originate from the design stage of roof construction, 15 selected projects which are designed by construction firms and are representatives of roof construction in North Cyprus are analyzed and compared with the International Building Codes which are discussed in Chapter 2 of the thesis.

According to International Building Code, the minimum slope for roofs is %1, however; the minimum suggested slope is %2 for built-up roofs (IBC, 2012). The designed slope for most of the evaluated flat roofs is %1. Examples of this problem are figures 56 and 57.

Considering weather resistance of the studied projects, according to the existing building standards, all roof intersections with walls, gutters, changes in the slope and its direction should be sealed with flashing materials and a precise detail of these flashings are essential for weather resistance of the building (IBC, 2012). However, none of the evaluated projects have shown a detail of flashings.

Additionally, in order to make copings and parapet walls weather resistant, a layer of non-combustible material with a width of not less than the width of parapet is essential according to IBC (IBC, 2012). Lack of this layer in all the cases which are constructed with parapet walls is the other defect which is found during the design process. [Figure 53, 54, 56, 57, 63]

According to rule number 1504 of Building Code, in order to prevent up-lift, roofs should be entirely fastened especially for low-sloped roofs the integrity must be kept (IBC, 2012). The roofs' fastener details are not observed for the evaluated projects.

The minimum roof slope which can be covered by clay tiles is %21 according to the International Building Codes (IBC, 2012). This rule is met in the analyzed projects. However, for roofs with a pitch less than %33, an underlayment is essential (IBC, 2012).

Figure number 52, 54, 55, 58, 64, 65, 66 have a slope less than %33 without this underlayment. Furthermore, International Building Codes necessitates the constructors to implement an interlayment installed shingle for slopes steeper than %33 (IBC, 2012). However, this rule is not met in the selected projects with pitch higher than %33. [Figure 54, 58, 62, 63]

Flashings are essential for junctions, vertical layers and valleys, all of the projects lack precise details of the flashing whenever they are required (IBC, 2012).

In case of enclosed attics [Figure 52, 55, 58, 62], cross ventilation is required. The minimum air space is 25mm which are not considered in any of these projects (IBC, 2012).

All external building elements which are in contact with environment must be covered with a continuous layer of air barrier. The details of this layer should be illustrated in precise details of any project especially in intersections (ASHRAE, 2012). None of the designed projects have shown a detail of this layer.

The minimum thermal insulation for roofs according to ASHRAE is discussed in the second chapter of this thesis. Lack of thermal insulation in many of the studied projects results in thermally uncomfortable conditions for the users. [Figure 52, 53, 56, 57, 62, 63, 64, 65, 66]

According to the existing literatures, roofs have shown best performance when thermal insulation is located toward inner layers of roof (Özdeniz & Hançer, 2005). However, in figure 54 it is located towards the external layers. Similarly, in figure 55 thermal insulation is placed on the inclined roof and above water insulation.

A layer should be installed on the warmer side of thermal insulation in winter for moisture control according to International Standards.

On the other hand, the minimum size of drains is 3 inch which is met in all the projects and in residential buildings the drained water can be transferred to the external flat surfaces like streets (IBC, 2012). All drainers must be covered by strainers which are not considered in any of the projects.

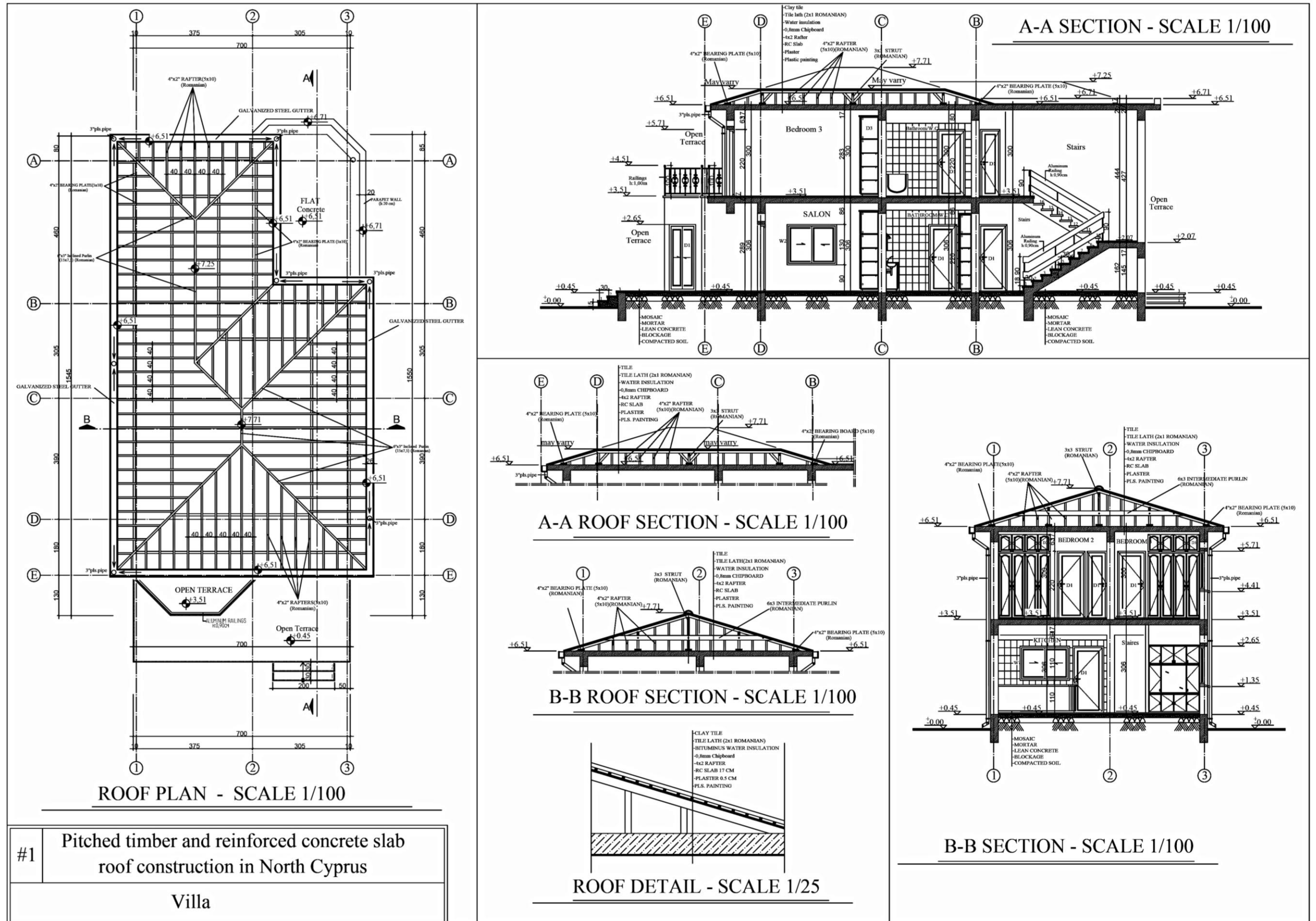

Figure 52. Standing timber roof construction in North Cyprus

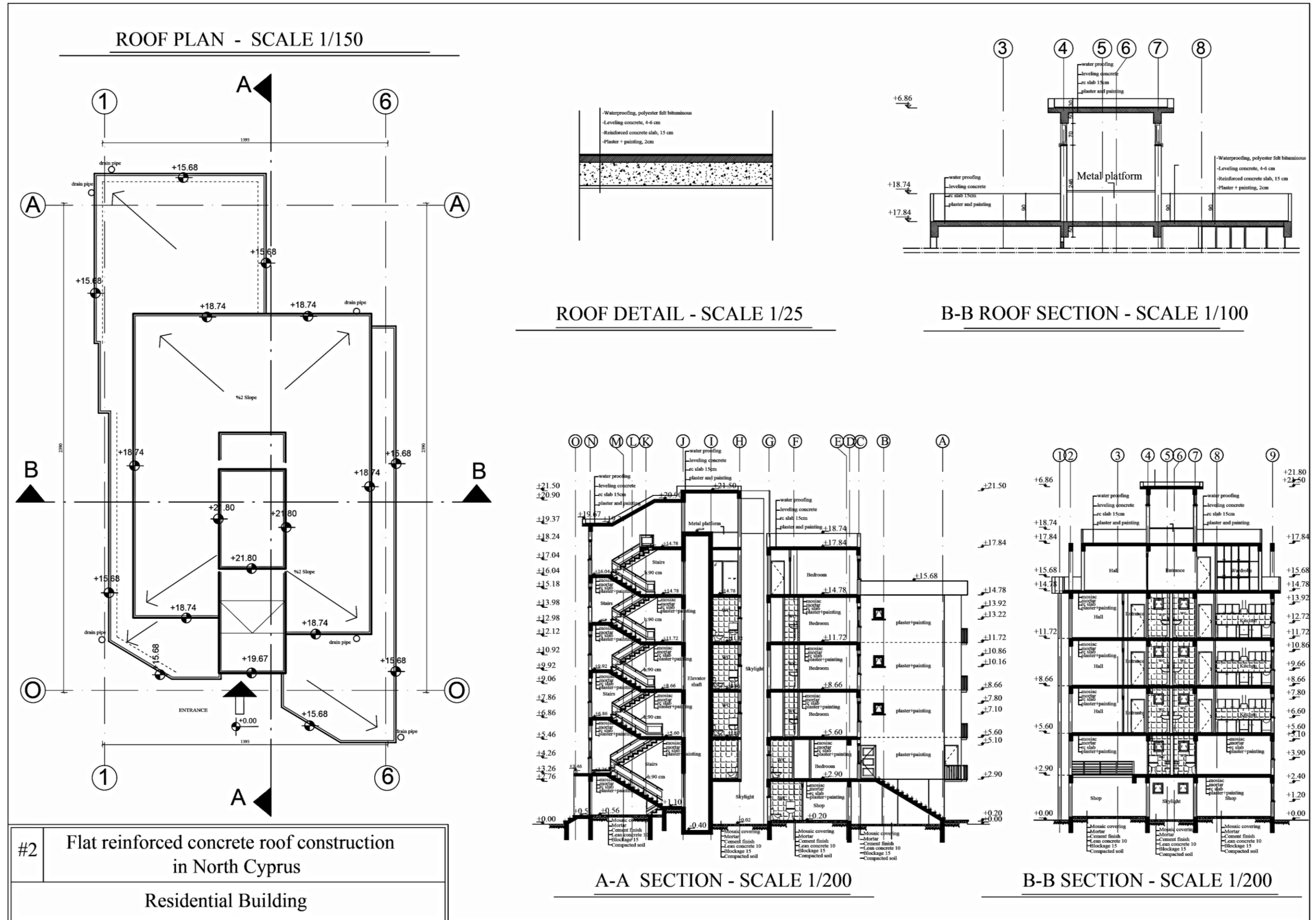

Figure 53. Flat reinforced concrete roof construction in North Cyprus

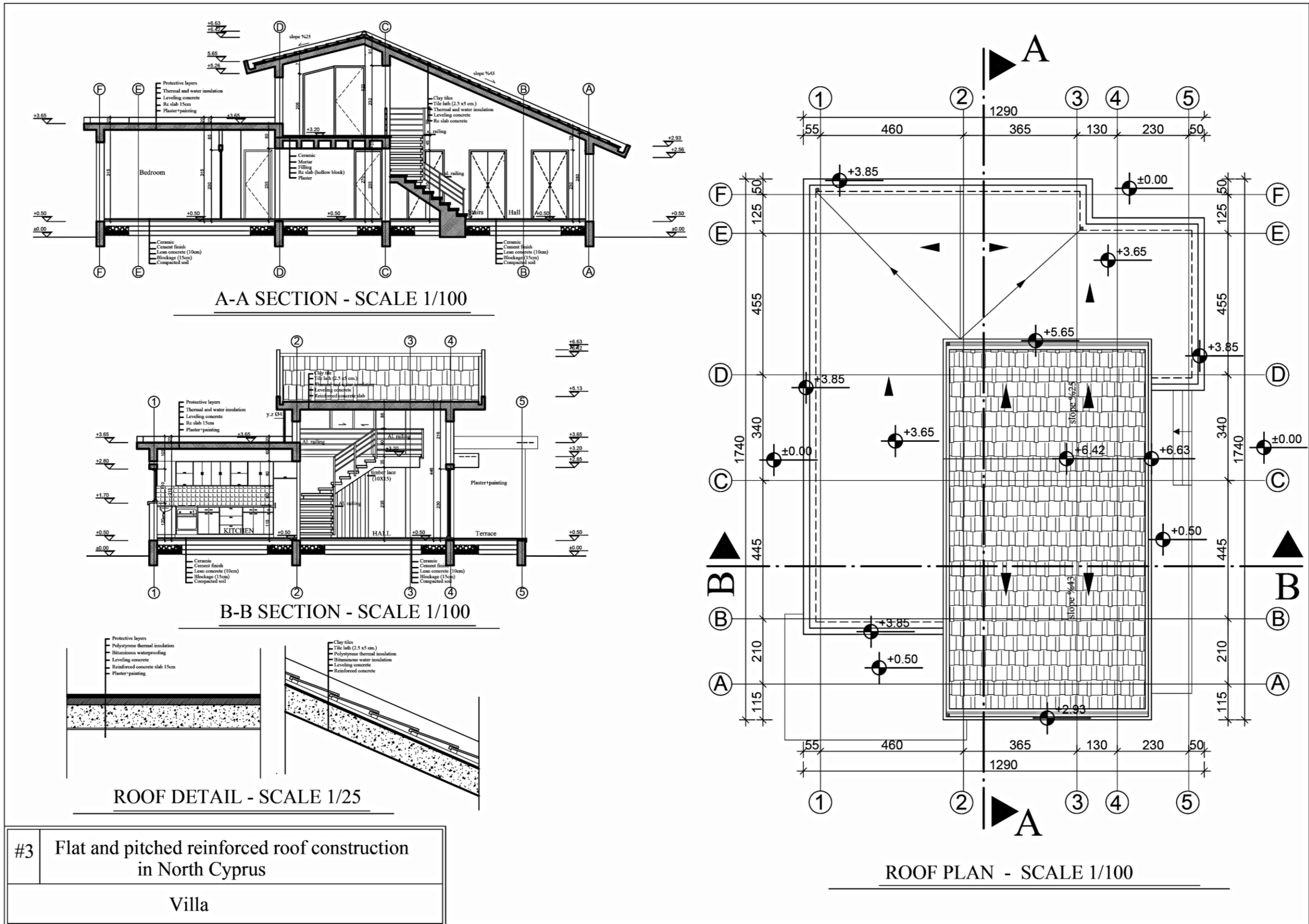
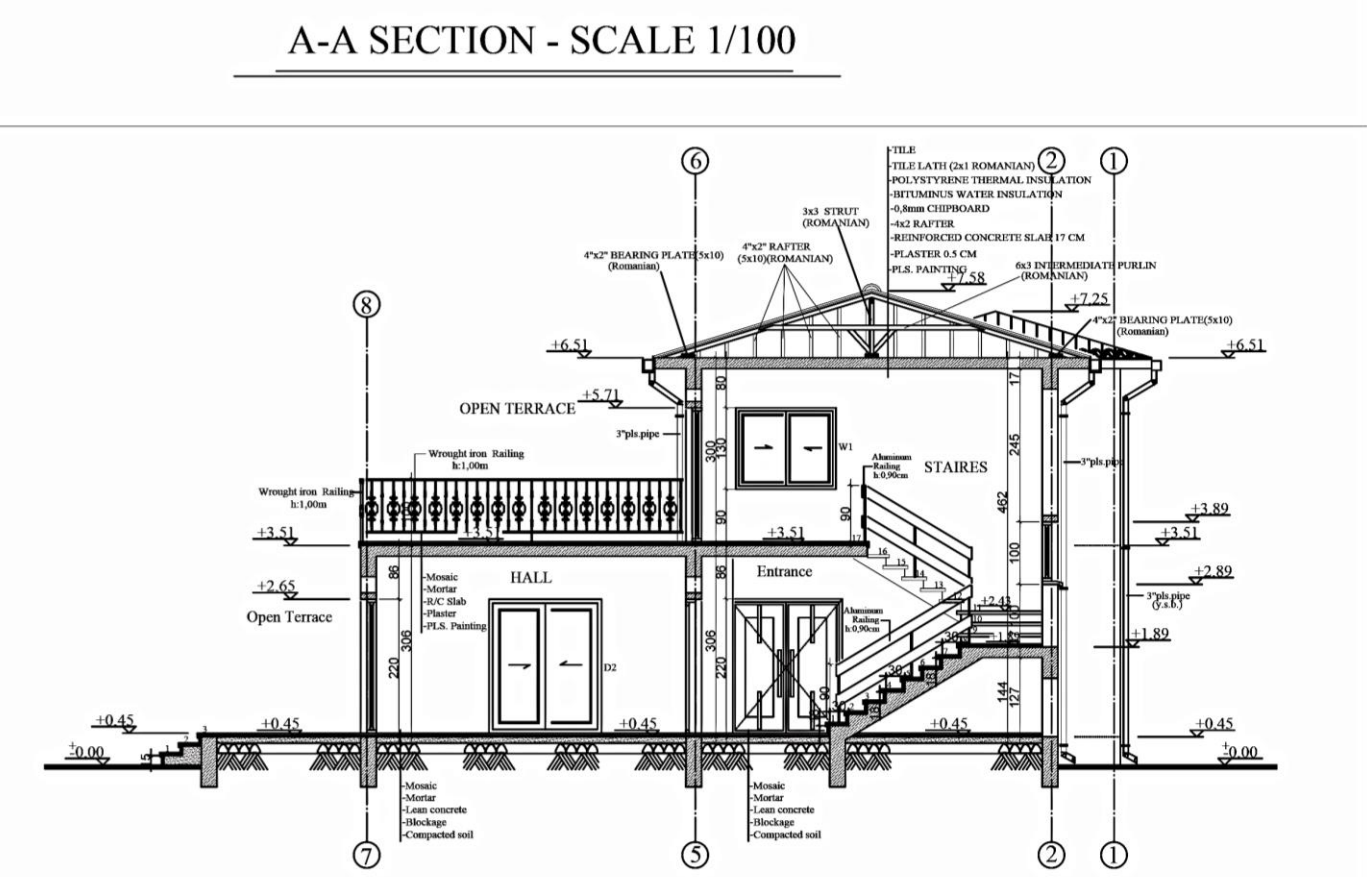
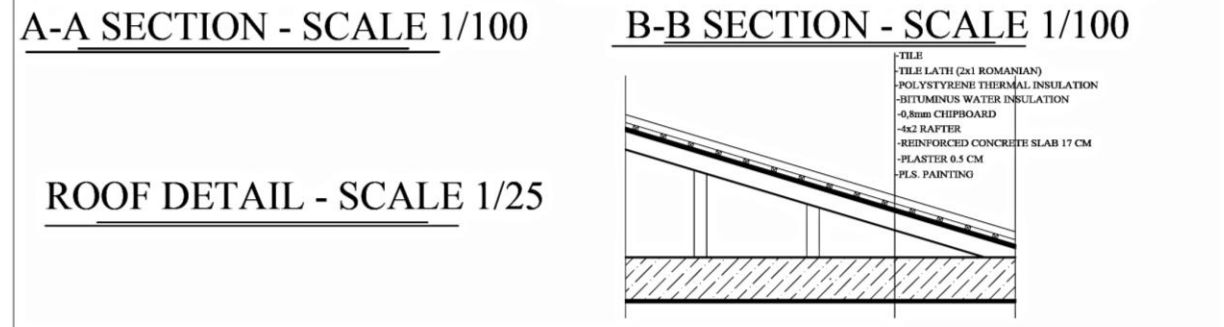
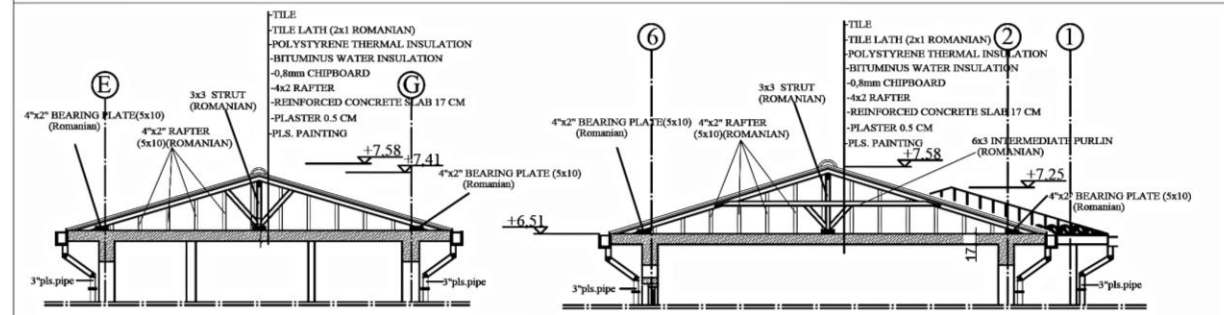
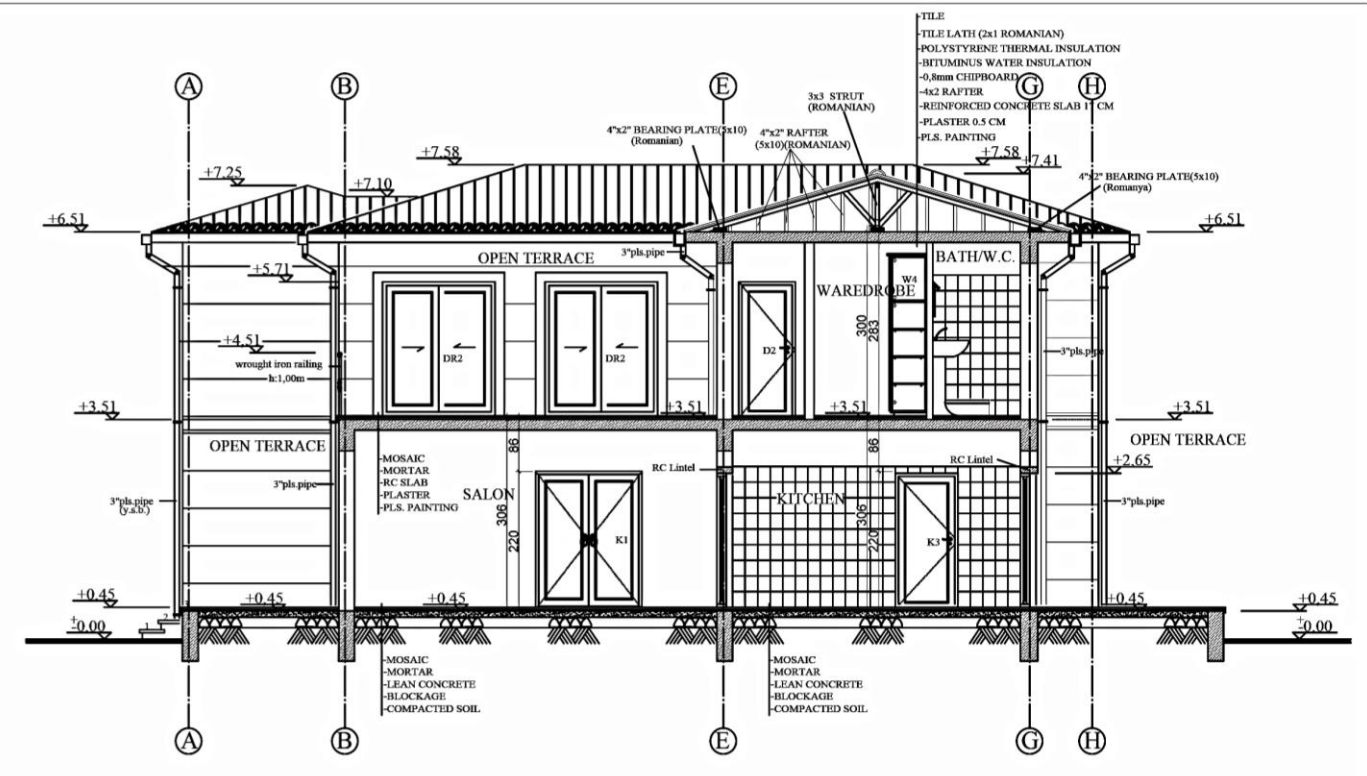
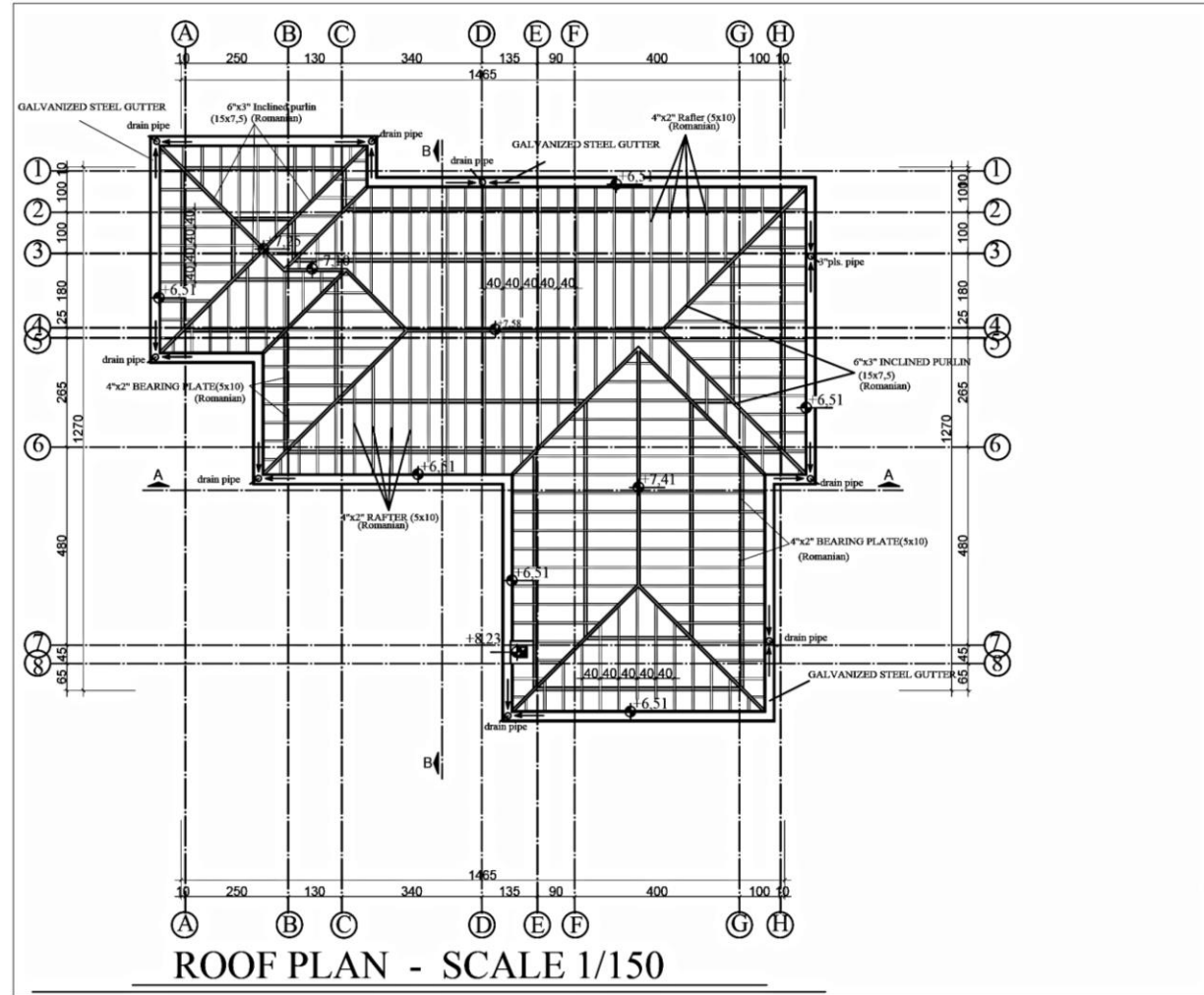

Figure 54. Inclined and flat reinforced concrete roof construction in North Cyprus



#4 Pitched timber and reinforced concrete slab roof construction in North Cyprus
Villa

Figure 55. Standing timber roof construction in North Cyprus

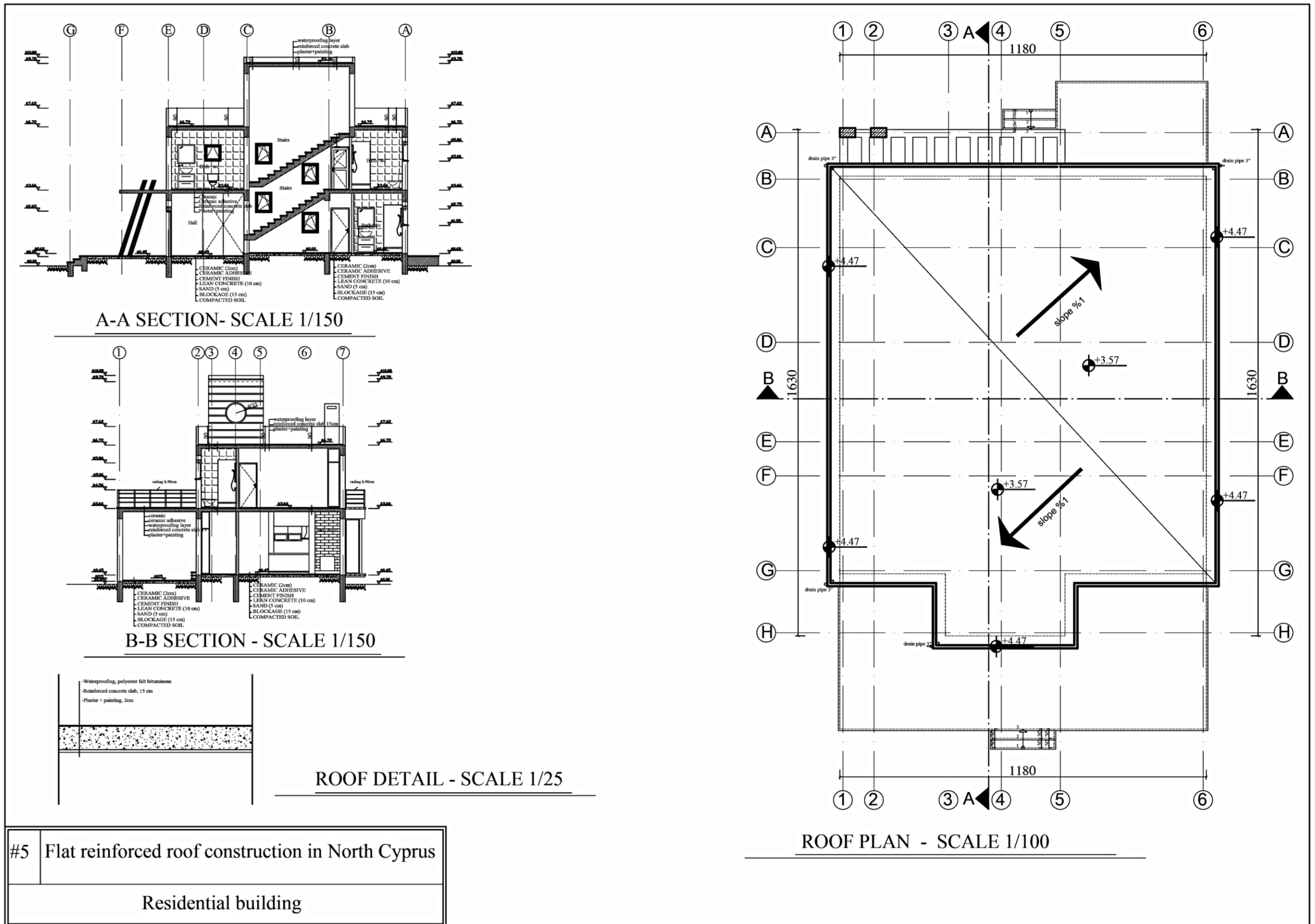

Figure 56. Flat reinforced concrete roof construction in North Cyprus

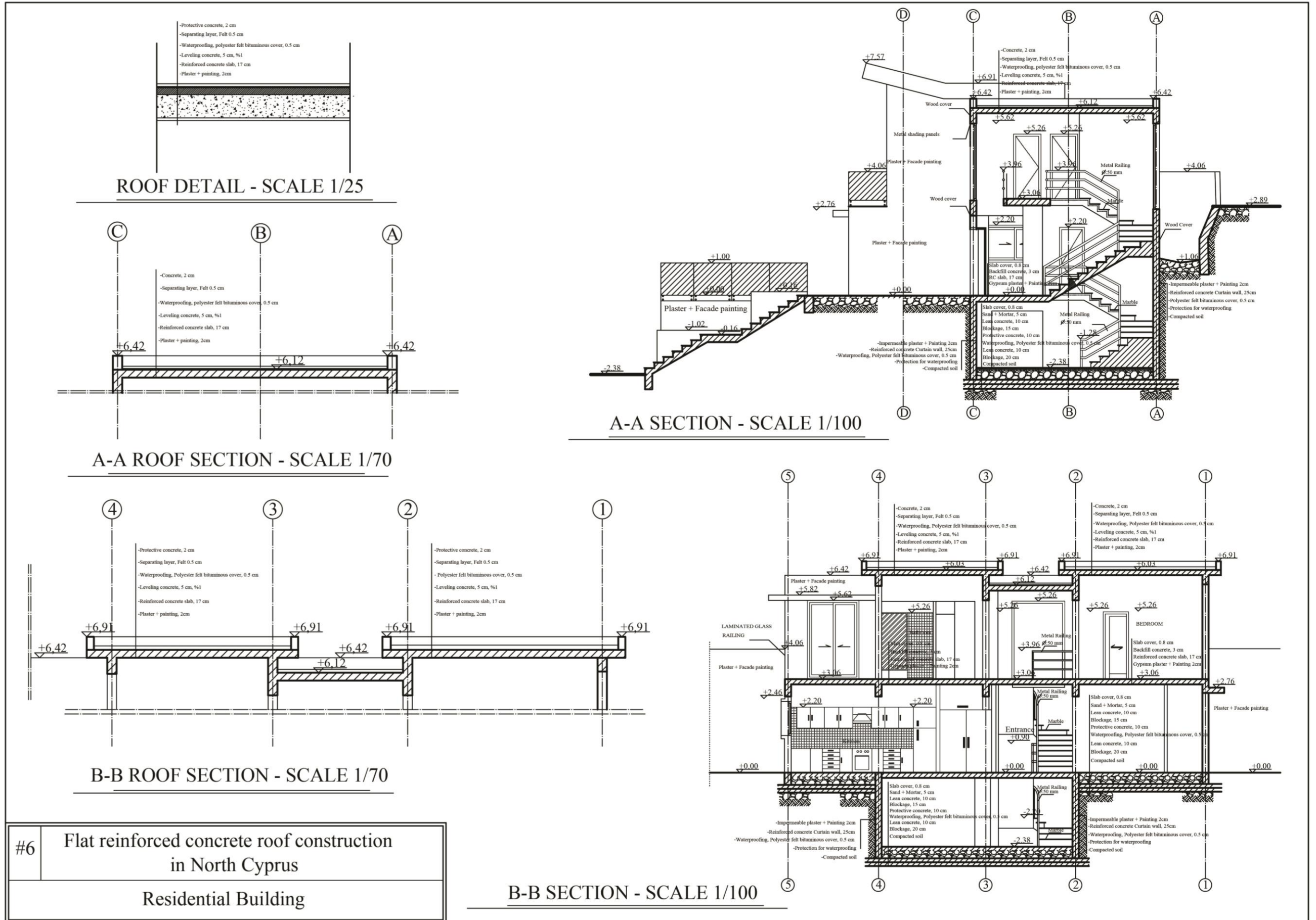
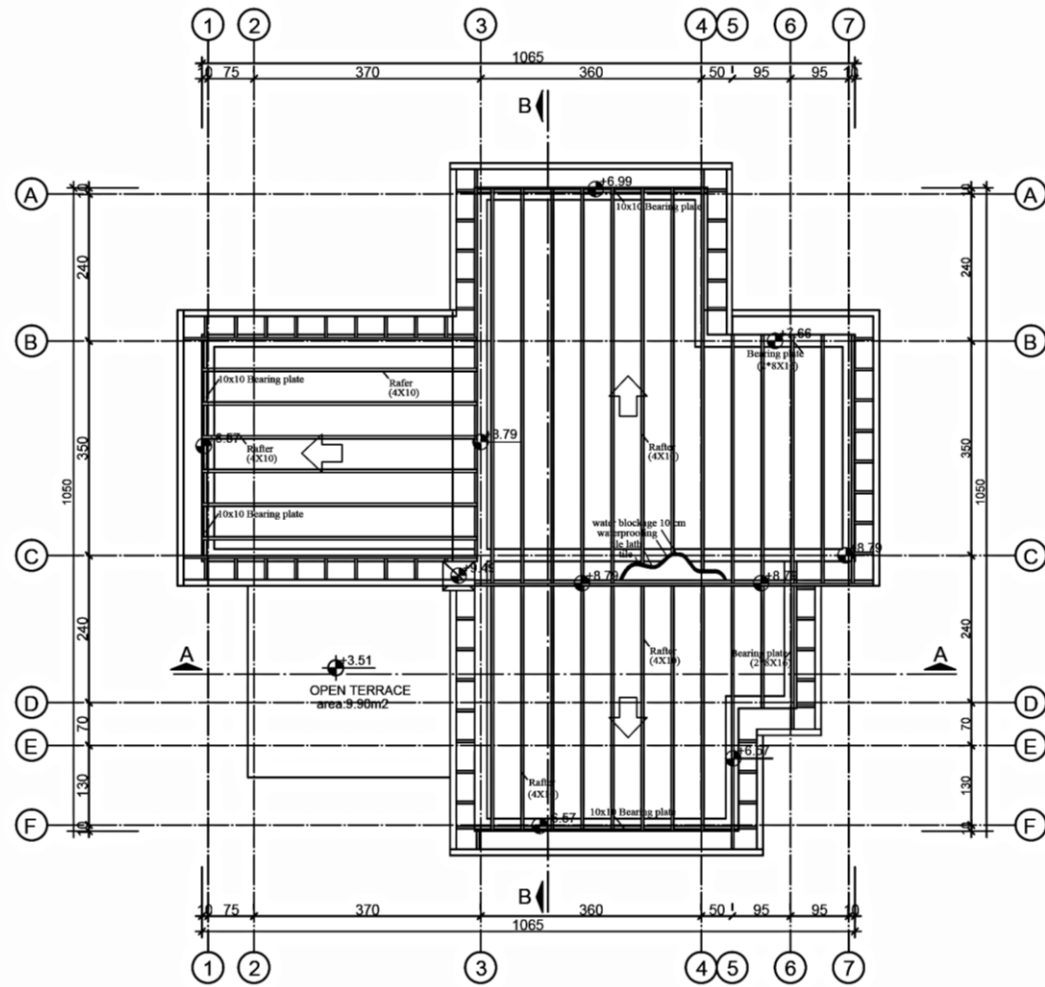
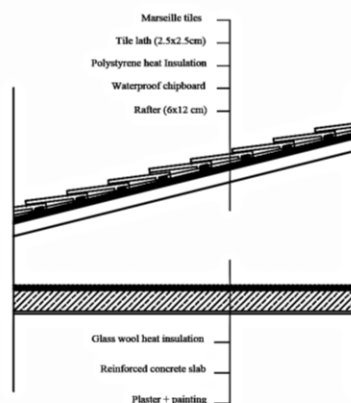

Figure 57. Flat reinforced concrete roof construction in North Cyprus



ROOF PLAN - SCALE 1/100

ROOF DETAIL - SCALE 1/25



#7 Pitched timber and reinforced concrete slab roof construction in North Cyprus

Villa

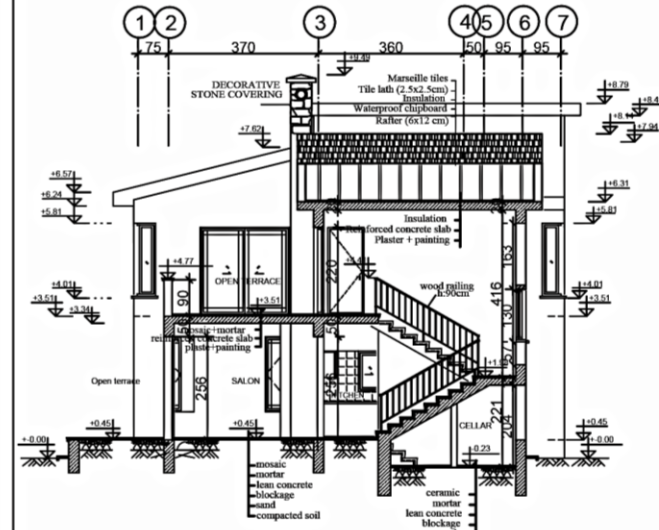

A-A SECTION - SCALE 1/150

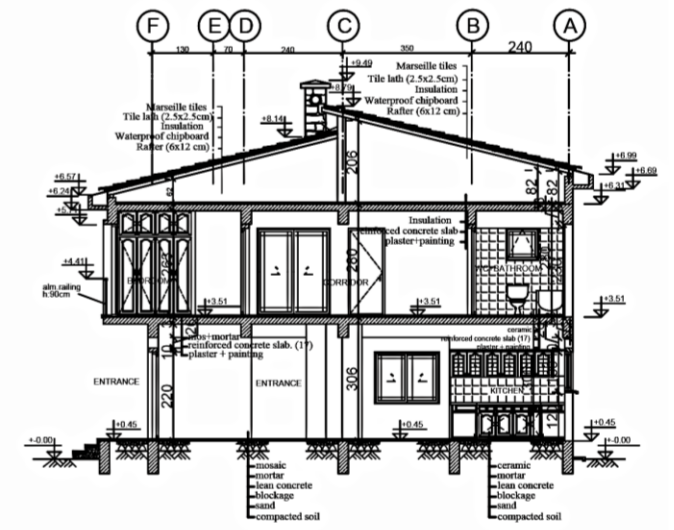

B-B SECTION - SCALE 1/150

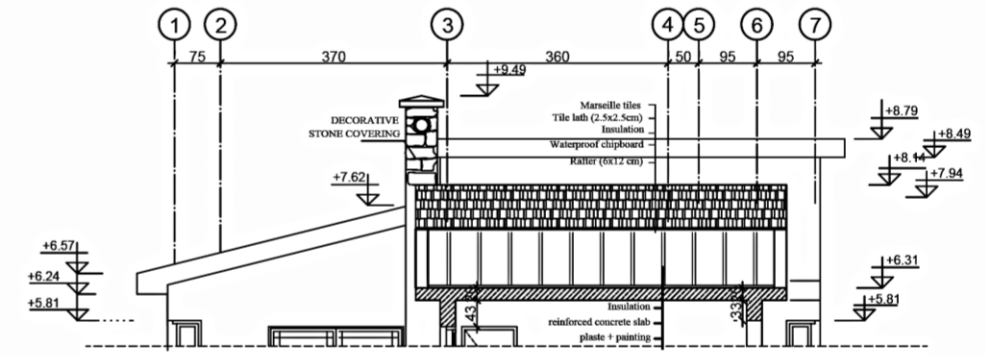

A-A ROOF SECTION - SCALE 1/100

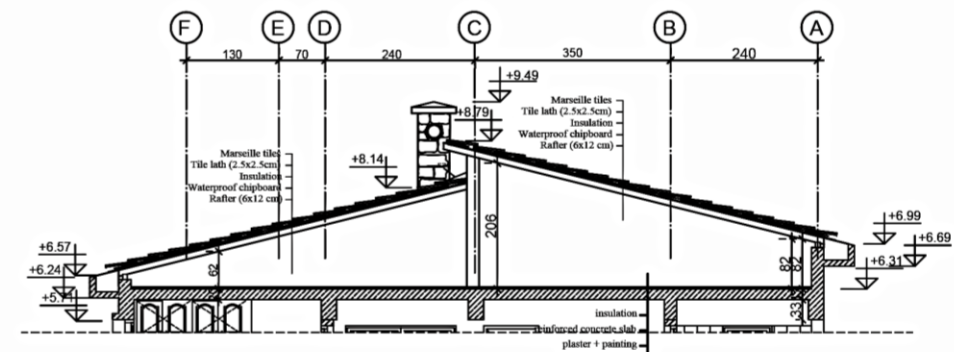

B-B ROOF SECTION - SCALE 1/100

Figure 58. Standing timber roof construction in North Cyprus

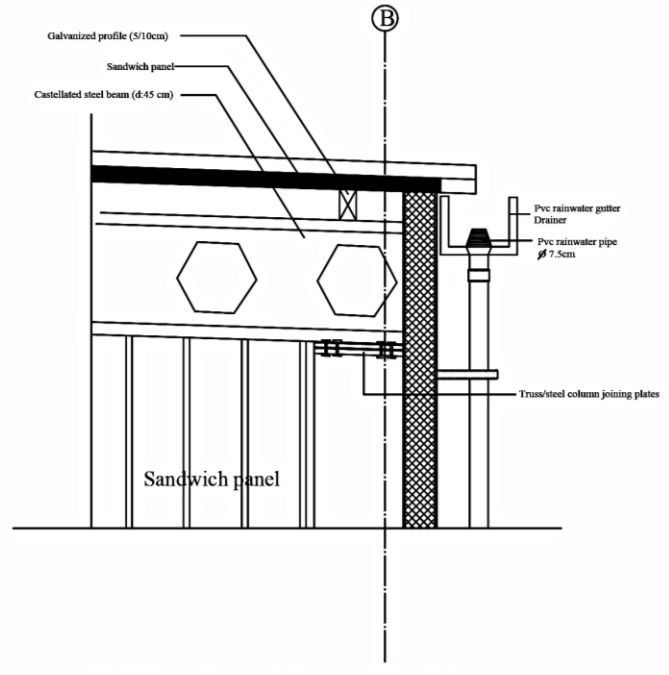

A1 DETAIL - SCALE 1/25

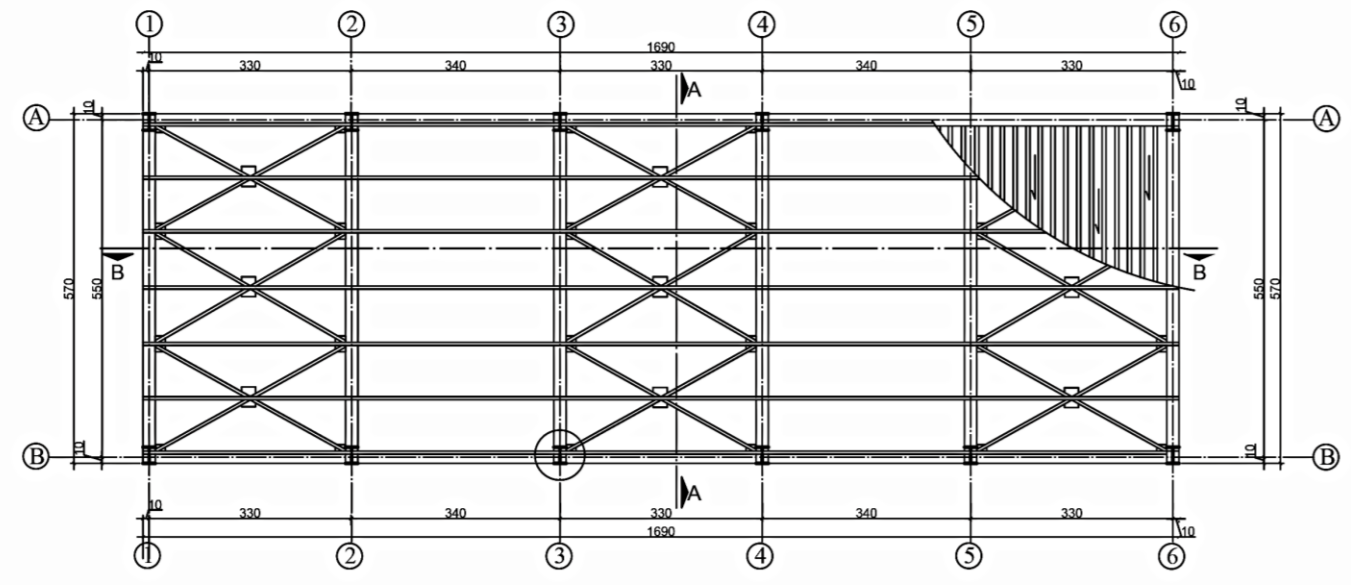

ROOF PLAN- SCALE 1/100

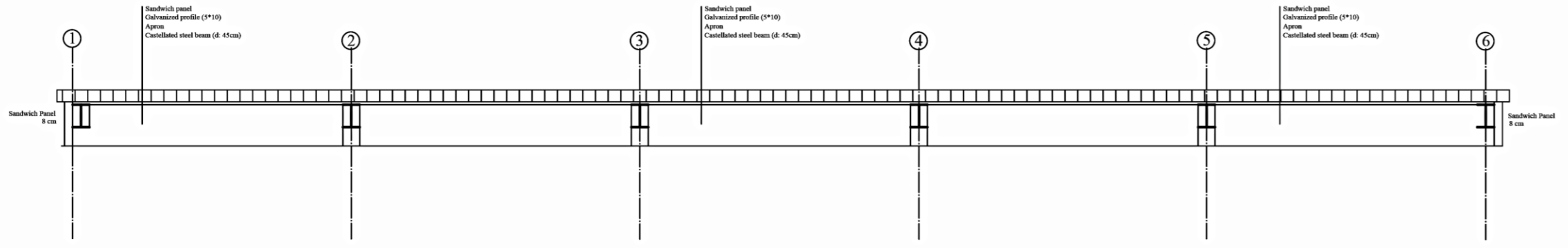

B-B ROOF SECTION - SCALE 1/50

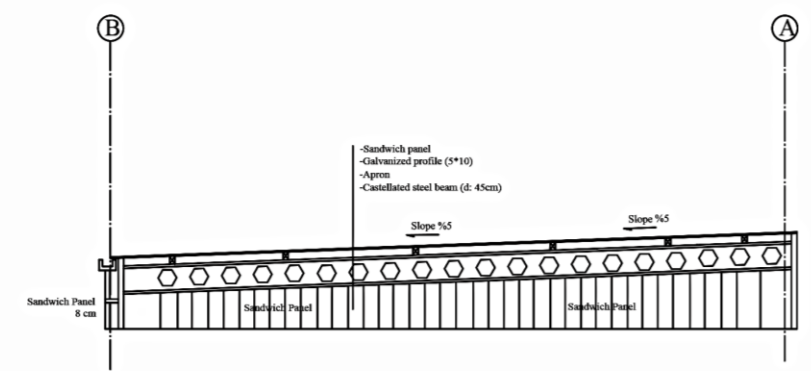

A-A ROOF SECTION - SCALE 1/50

#8	Low sloped metal roof construction in North Cyprus
Studio	

Figure 59. Low sloped metal roof construction in North Cyprus

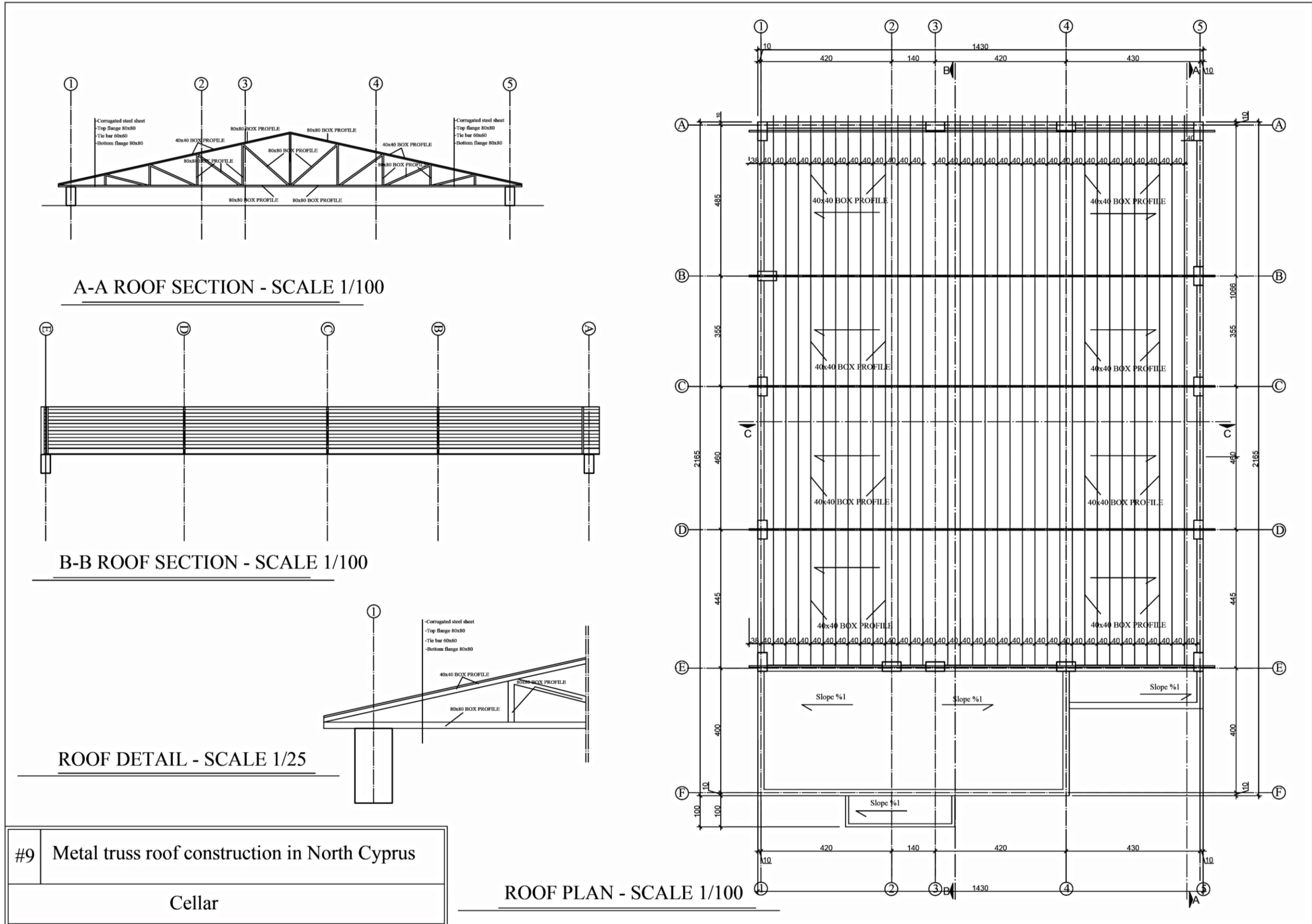
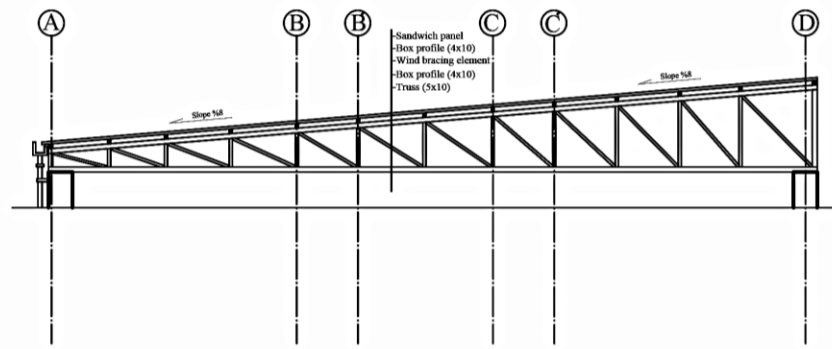

Figure 60. Metal truss construction in North Cyprus



A-A ROOF SECTION - SCALE 1/50



B-B ROOF SECTION - SCALE 1/100

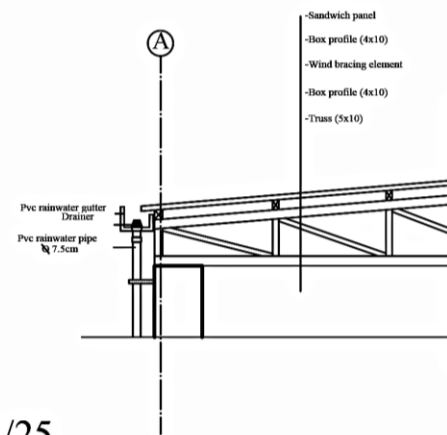

ROOF DETAIL - SCALE 1/25

#10	Low sloped metal roof construction in North Cyprus
	Cellar

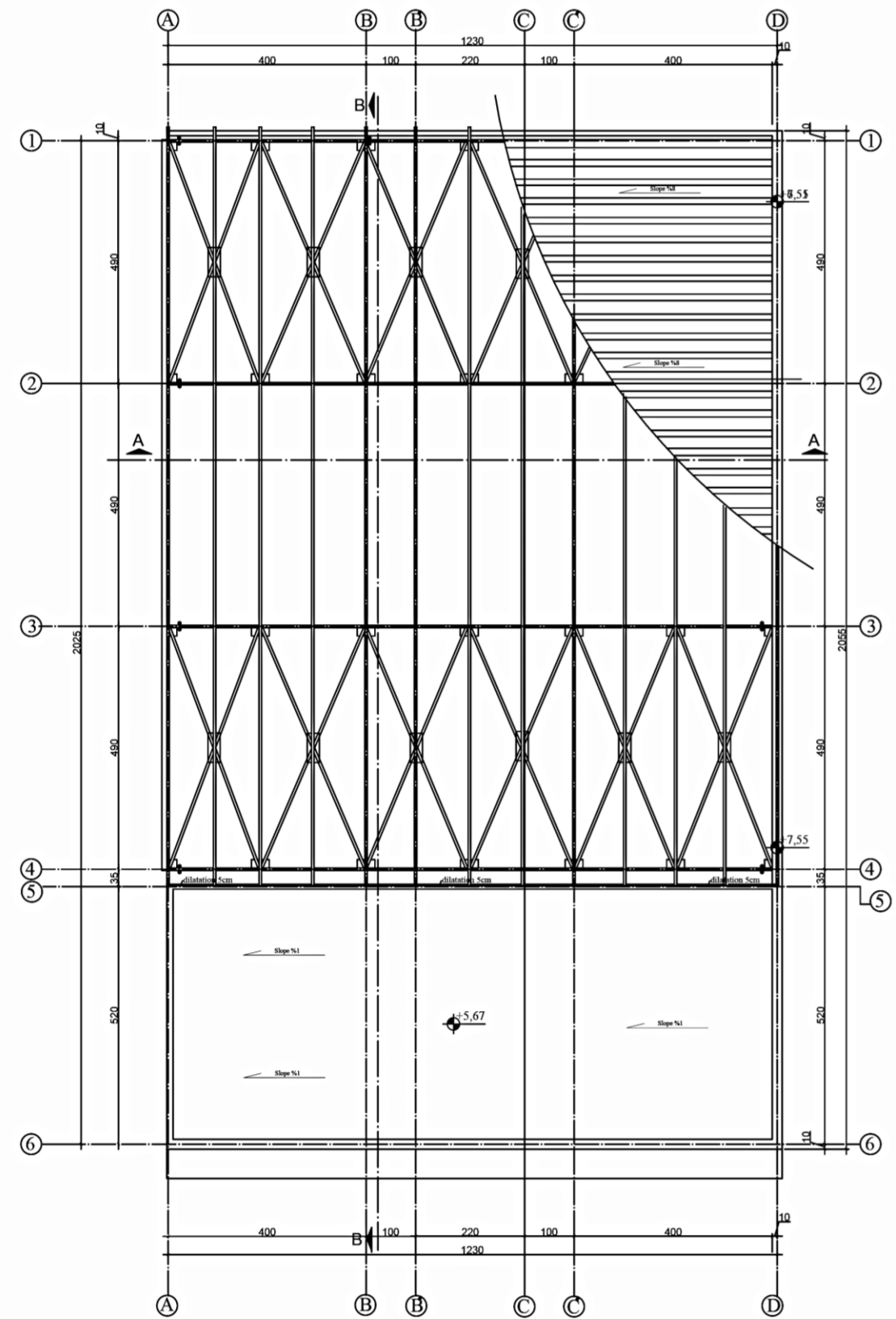

ROOF PLAN - SCALE 1/100

Figure 61. Low sloped metal roof construction in North Cyprus

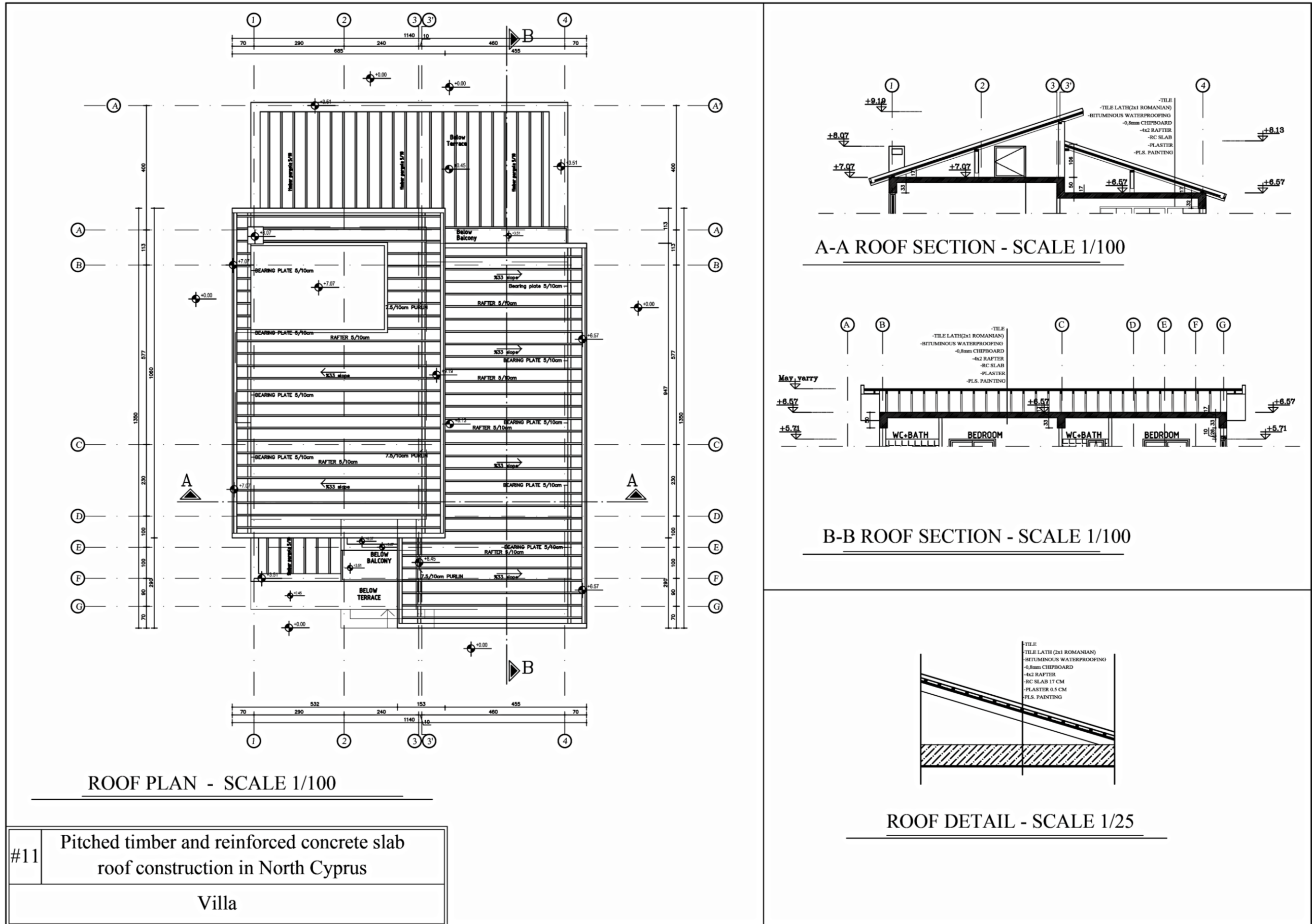
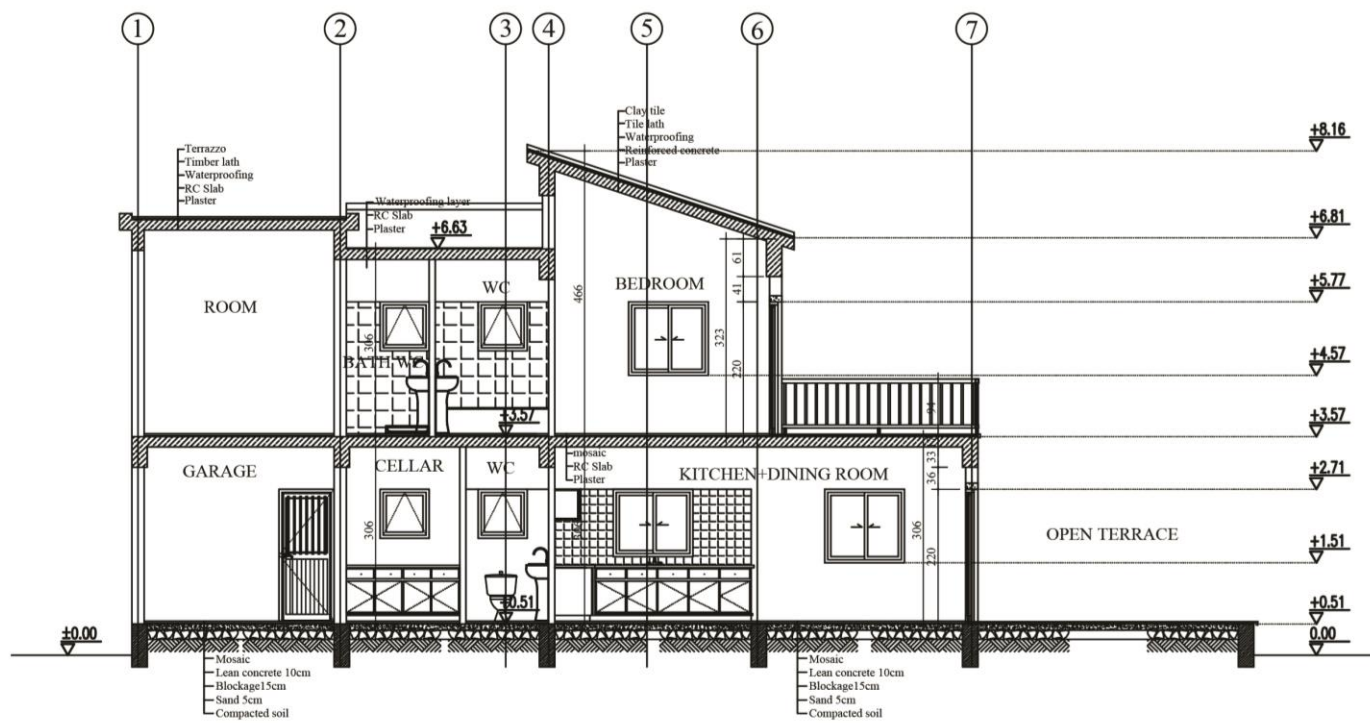
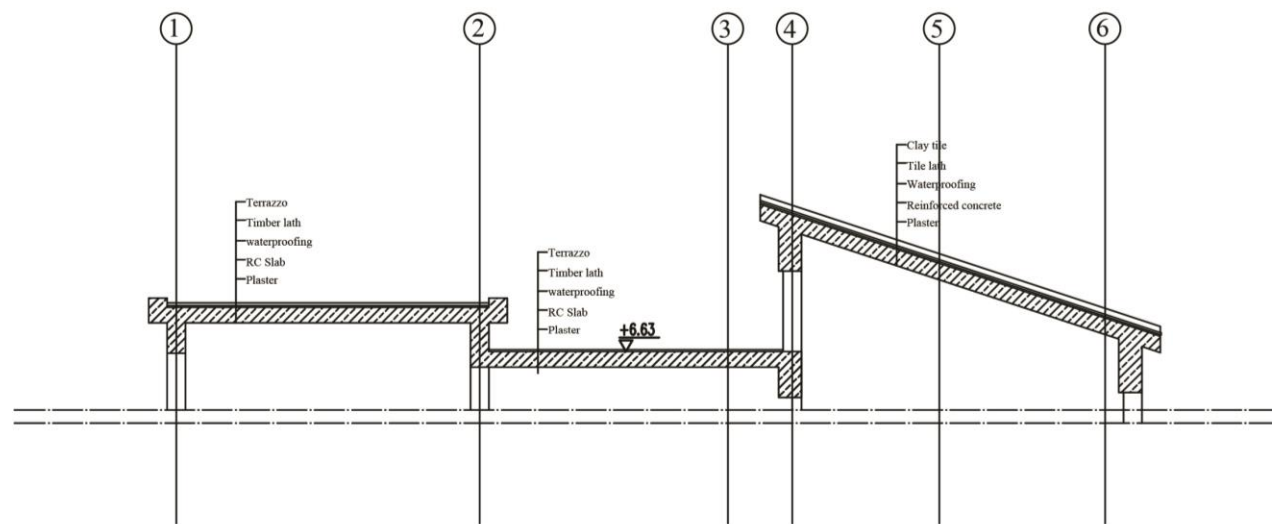

Figure 62. Standing timber roof construction in North Cyprus



A-A SECTION - SCALE 1/100



A-A ROOF SECTION - SCALE 1/70

#12

Pitched and flat reinforced concrete roof construction in North Cyprus

Villa

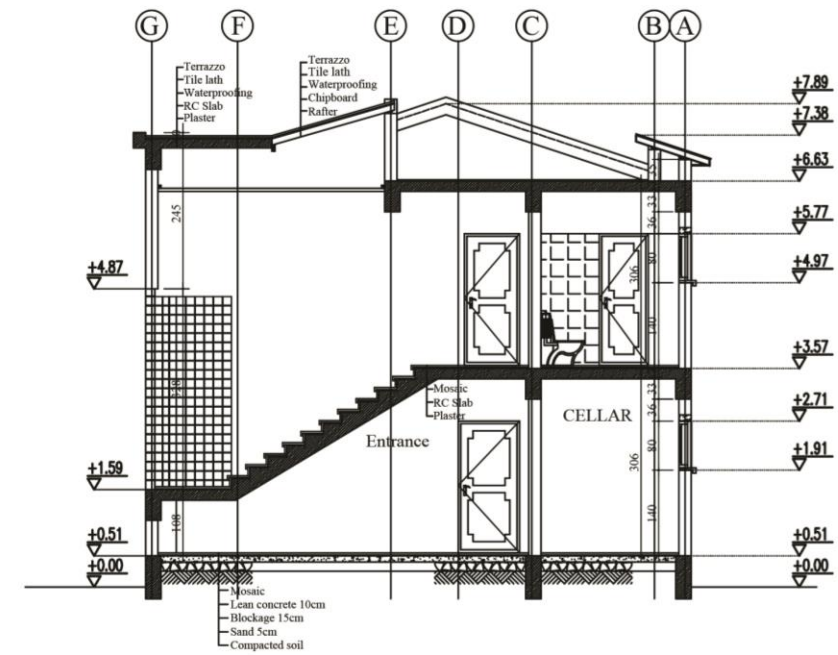

B-B SECTION - SCALE 1/100

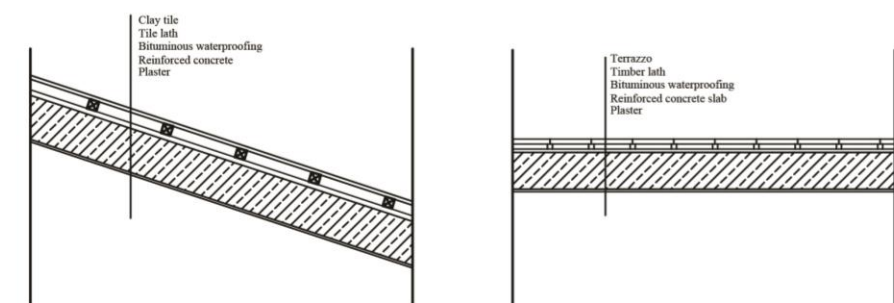

ROOF DETAIL - SCALE 1/25

Figure 63. Inclined and flat reinforced concrete roof construction in North Cyprus

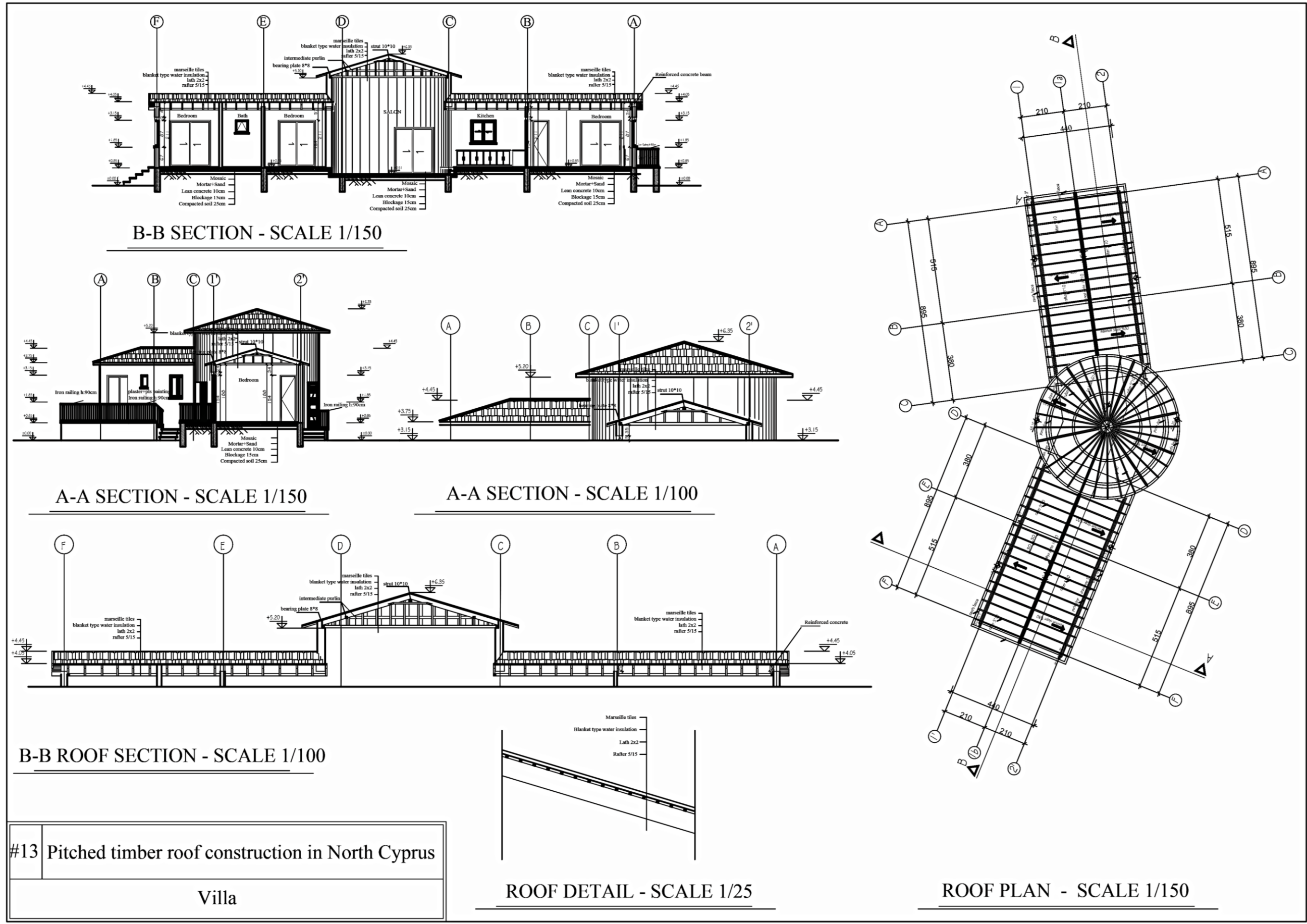
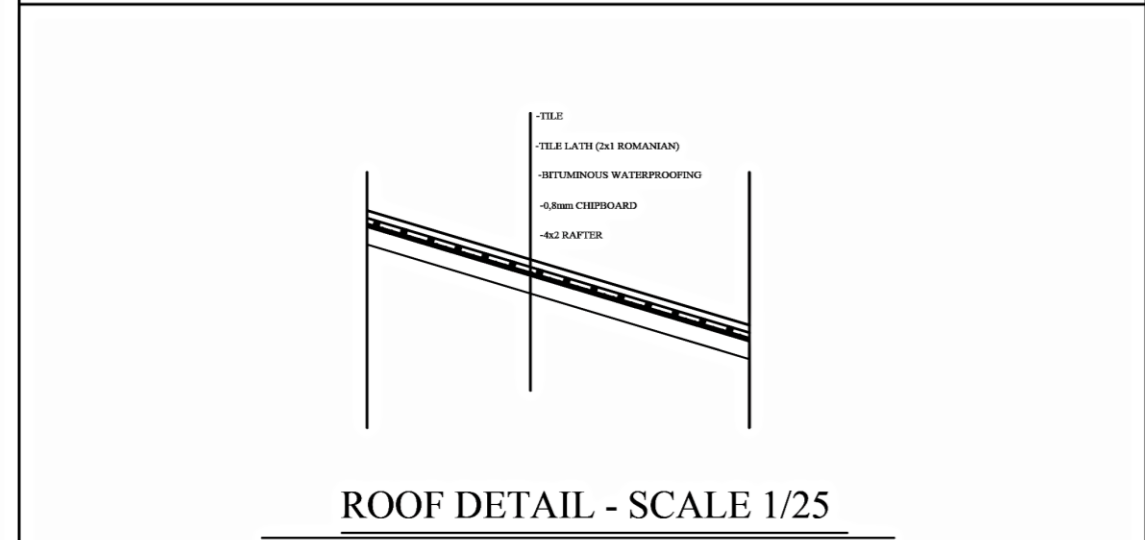
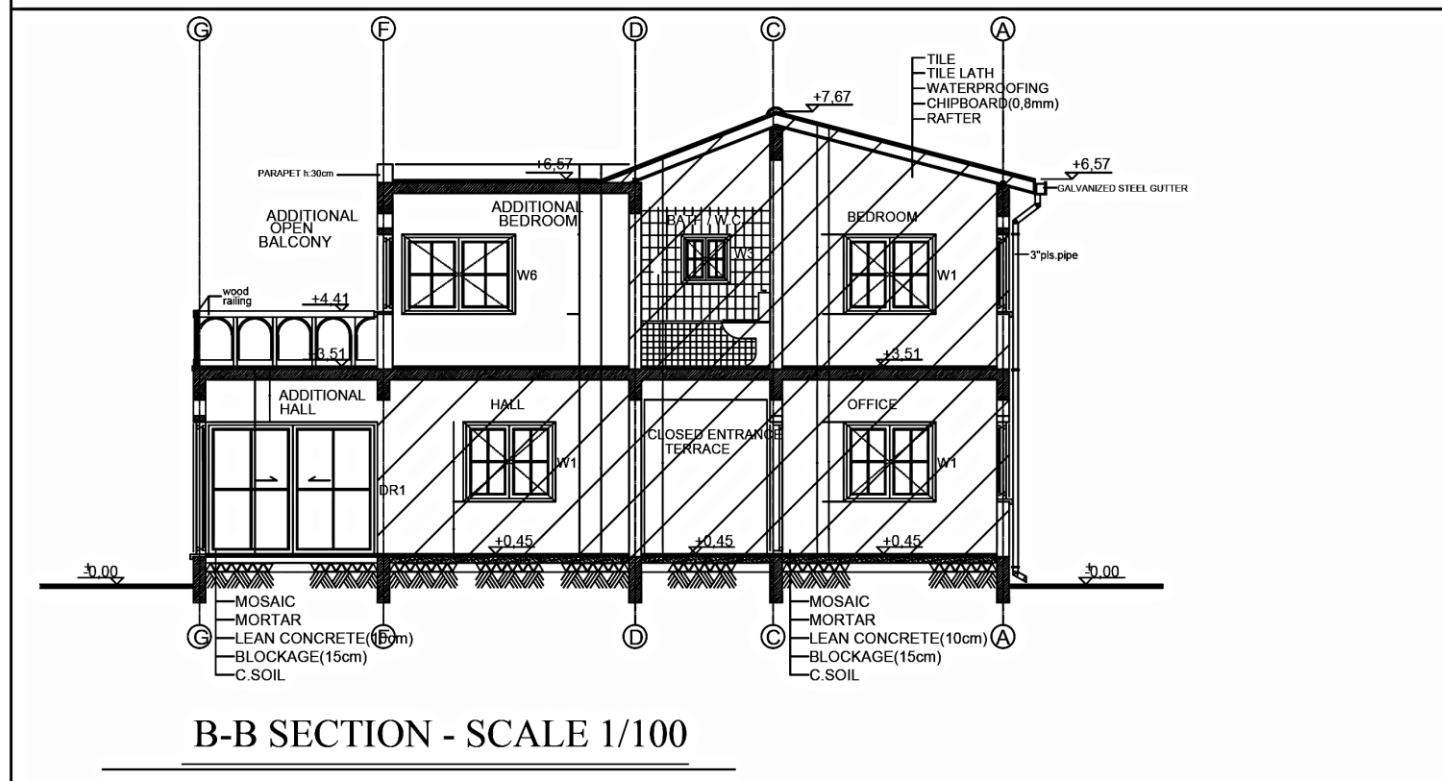
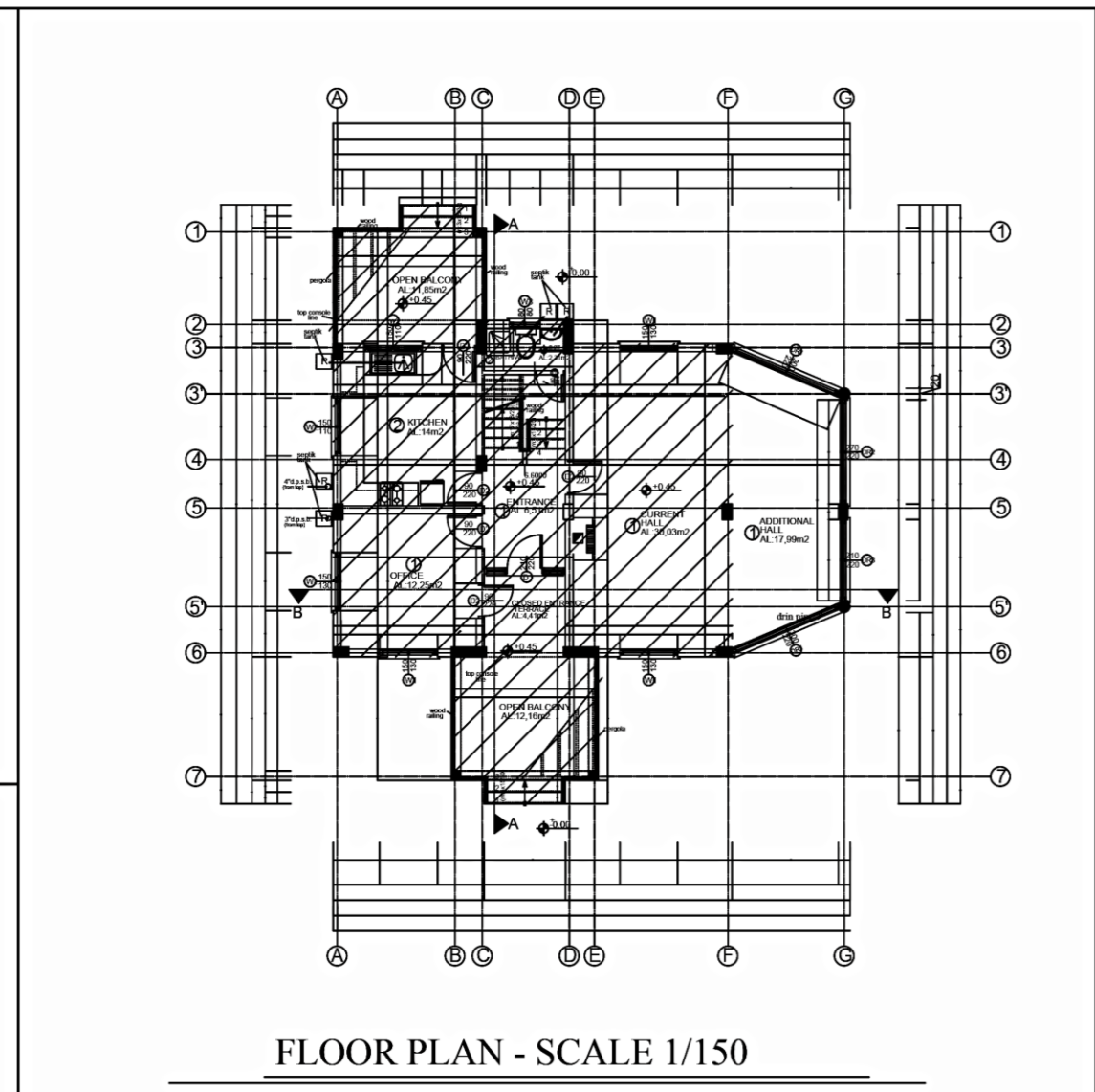
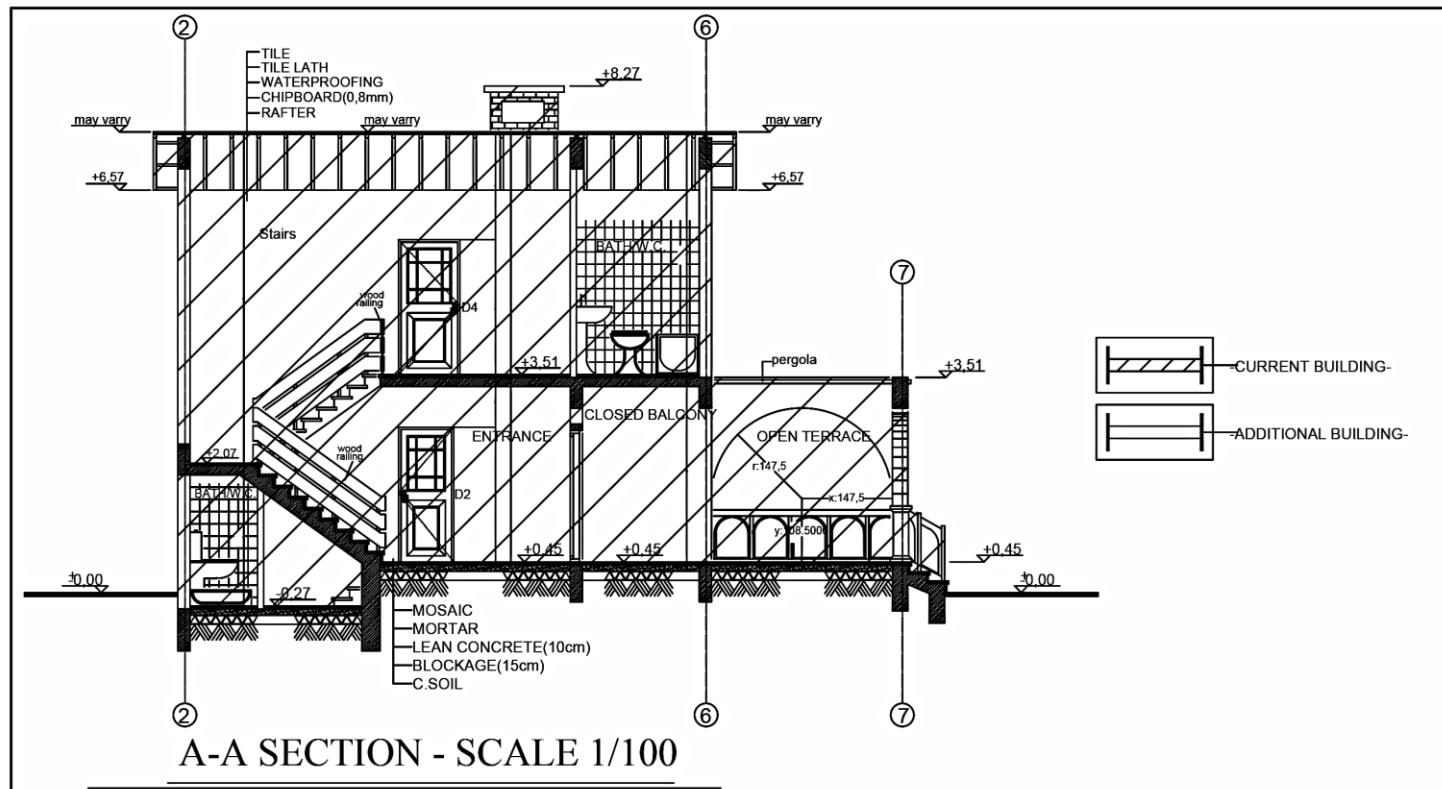
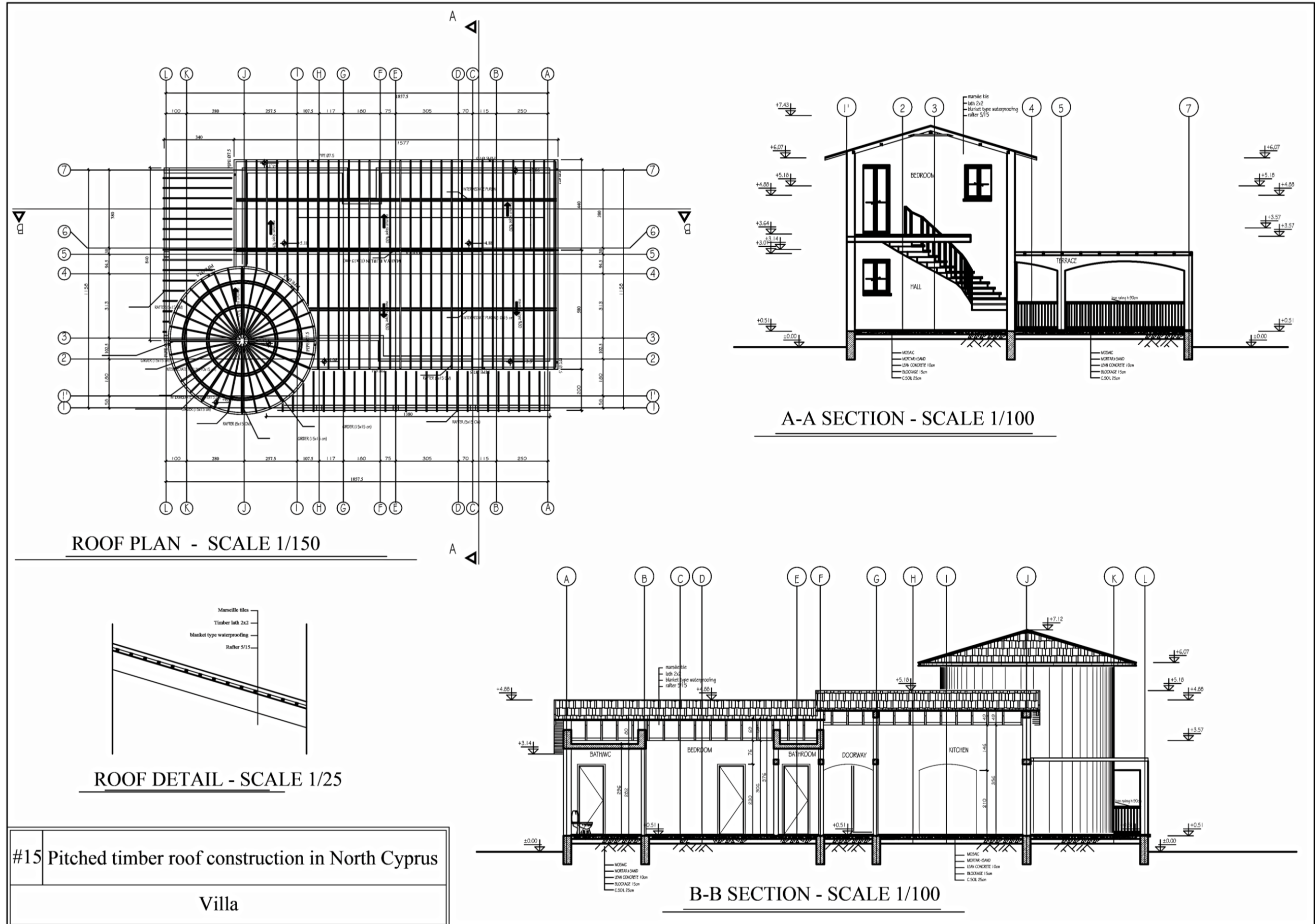

Figure 64. Inclined reinforced concrete roof construction in North Cyprus



#14 Pitched timber roof construction in North Cyprus
Villa

Figure 65. Pitched timber roof construction in North Cyprus



#15 Pitched timber roof construction in North Cyprus
Villa

Figure 66. Pitched timber roof construction in North Cyprus

3.10 Findings on Roof Defects According to the Owners

Roof defects are also asked from the selected building owners. A list of common roof problems are given to the users and they are asked to choose maximum 5 problems that they have faced during 5-6 years of occupancy. Most of the users have selected thermal comfort. With a slight difference drainage is selected as the mostly observed roof defect. Then comes resistance to heat and appearance. Cost, fire resistance and wind resistance are found to cause the least problems. [Figure 67]

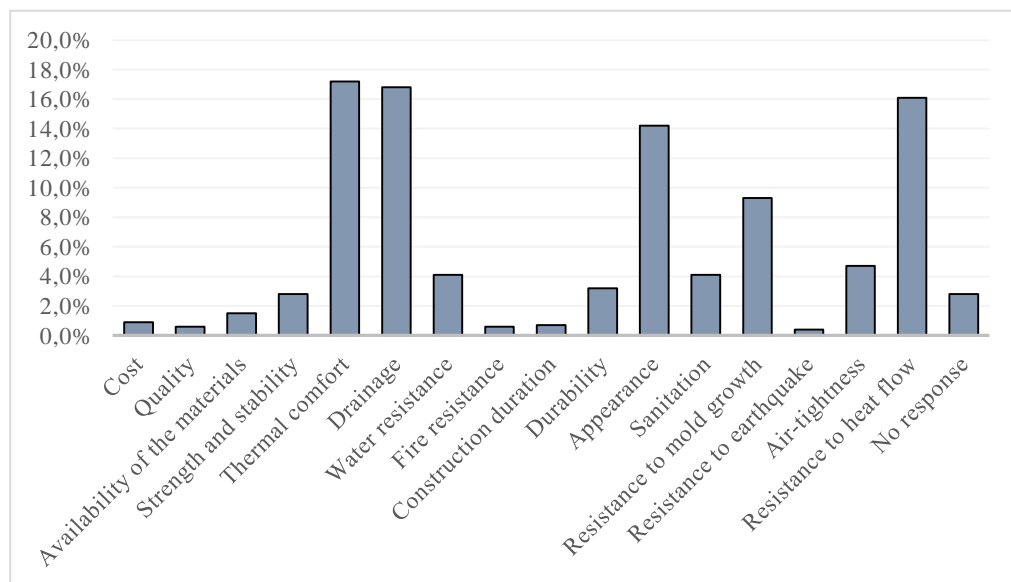

Figure 67. Roof defects according to the owners

3.11 Findings on Roof Defects According to the Constructors

Roof defects are also asked from the selected constructors. They are asked to choose maximum 5 of the listed defects that they believe are commonly occurring in North Cyprus. Drainage (%14.90) was the most selected problem. Resistance to heat flow, thermal comfort, sanitation were other observed roof defects. Wind resistance and fire resistance are not selected by any of the constructors. [Figure 68]

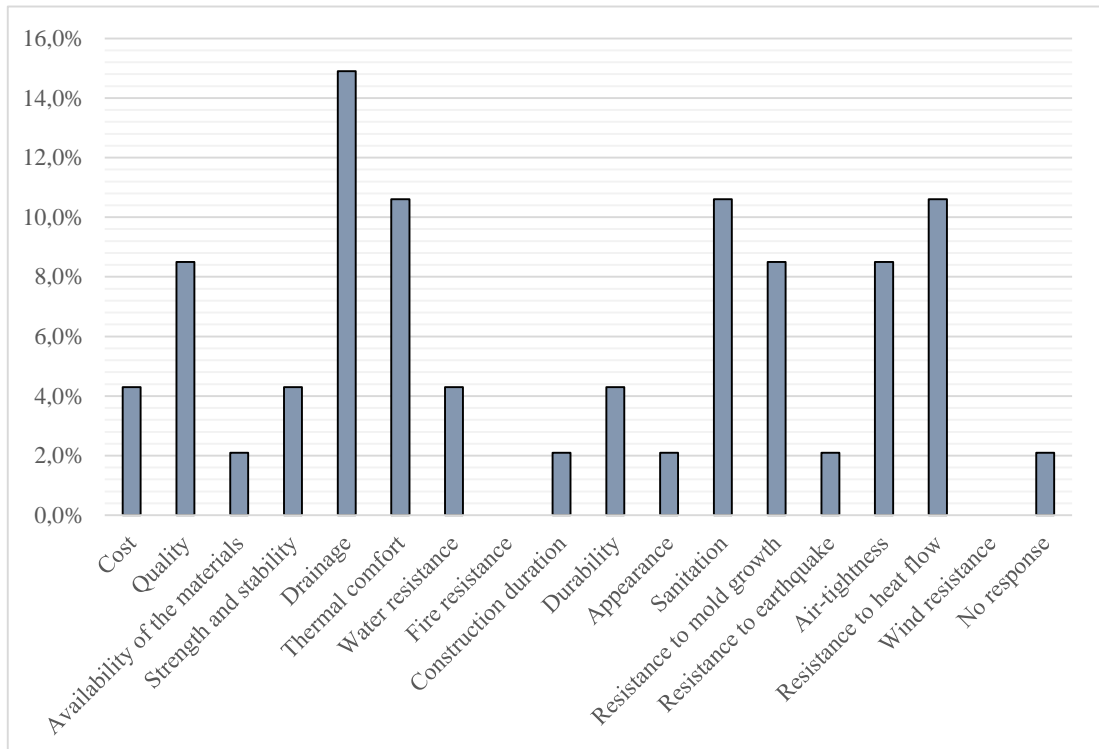

Figure 68. Roof defects according to the constructors

3.12 Discussions and Suggestions

This section of chapter analyzes commonly observed roof problems in TRNC, discusses them and suggests solutions. Firstly, the building defects which originate during the construction process are evaluated by analyzing the existing Building Codes and comparing them with what is constructed in North Cyprus. Table 20 to 25 are demonstrating photos which are taken from defective flat roofs [Table 20, 21, 22, 23, 24, 25] and pitched roof problems are shown in table 27 to 31.

One of the most common problems of flat roof construction, is drainage. This problem causes ponding, water stains on both parapet walls and external walls and imposes extra load to the roof. According to the International Building Code, the minimum slope of flat roofs is %2 (IBC, 2012). However problems in workmanship resulted in

improper leveling in the observed projects. In some cases the drain pipes do not continue to the ground level and the rainwater pours on the external walls or columns.

Another defects which originated in the construction process, are improper roofing. Splits, cockles and ridging, lap or joint failure are examples of this type of problems. Furthermore, according to IBC in 2012, dormers should be built with similar technique with roofs or external walls, however; the intersections are not constructed properly in many cases which are observed by the author.

Fasteners for installing clay tiles should be applied according to the International Standards (IBC, 2012). Improper workmanship in the existing cases have resulted in the broken and loose tiles.

Other problems are related to the valley flashing. IBC necessitates constructors to apply at least 28 cm flashing for each side of the valleys (IBC, 2012) which are not applied in the observed cases.

Beside construction defects, some other problems are caused as a result of poor maintenance. These problems are also observed and discussed in this section.

Most of the roofing membranes in flat roofs of TRNC are punched by various elements like solar panels and water tanks. Lack of proper maintenance affects the appearance and also the performance of the roofing layer.

One of the major defects related to these types of roofs in North Cyprus is growing mold, vegetation and algae over roof tiles. This problem is caused as a result of lack of proper maintenance.

Loose or slipped roof tiles are also observed in many cases which occur as a result of improper design or maintenance.

Table 20. Discussions and suggestions for common flat roof defects in North Cyprus (Suggestions from Schunck, 2010)







Flat Roof	Common Roof Defects and Suggestions for Flat Roofs in North Cyprus			
<p>Problem: Ponding</p>	<p>Reason of Problem</p>	<p>Suggestion 1 (waterproofing above insulation)</p>	<p>Suggestion 2 (with impermeable concrete)</p>	<p>Suggestion 3 (for vehicular traffic)</p>
	<p>Reason: Lack of proper leveling and sloping</p> 			
<p>Problem: Lack of cover for drains</p>	<p>Reason of Problem</p>	<p>Suggestion 1 (waterproofing above insulation)</p>	<p>Suggestion 2 (for foot traffic)</p>	
	<p>Reason: Lack of cover for drains results in blocked pipes and improper drainage</p> 			
<p>Problem: Improper roof and wall joint</p>	<p>Reason of Problem</p>	<p>Suggestion 1 (waterproofing above insulation)</p>	<p>Suggestion 2 (for foot traffic)</p>	<p>Suggestion 3 (for vehicular traffic)</p>
	<p>Reason: Lack of proper design details results in construction without knowledge</p> 			

Table 21. Discussions and suggestions for common flat roof defects in North Cyprus (Suggestions from Schunck, 2010 and Özdeniz & Hançer, 2005)



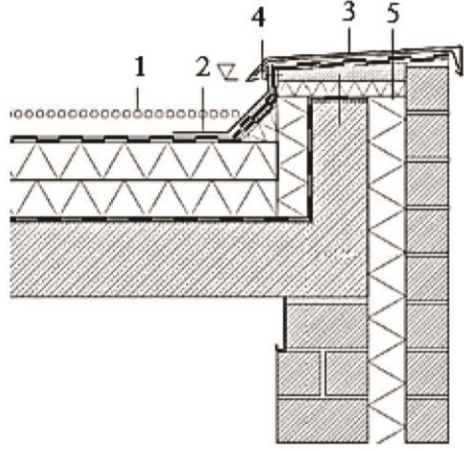
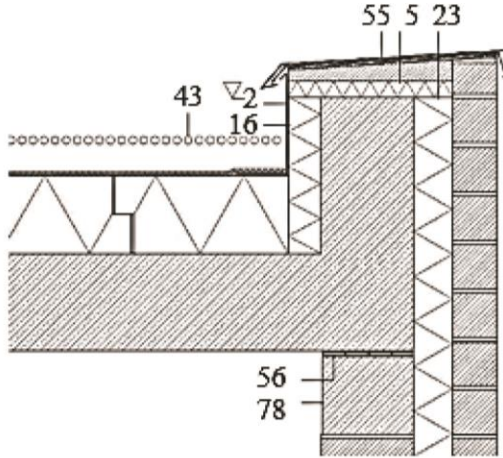
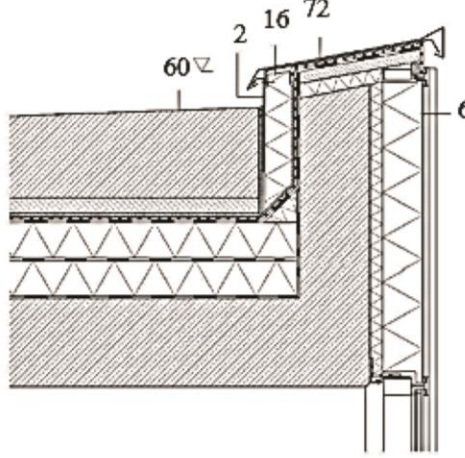

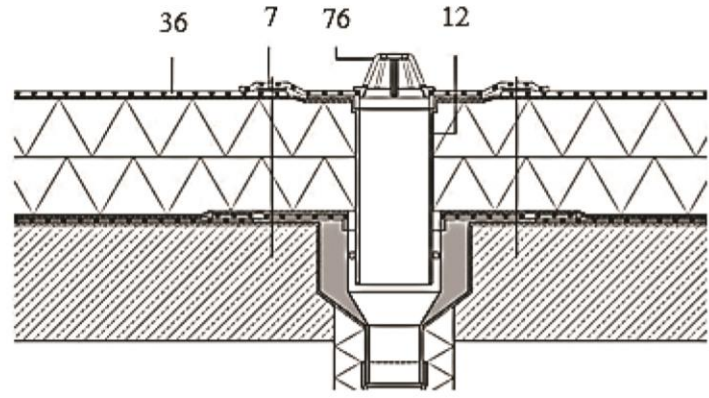
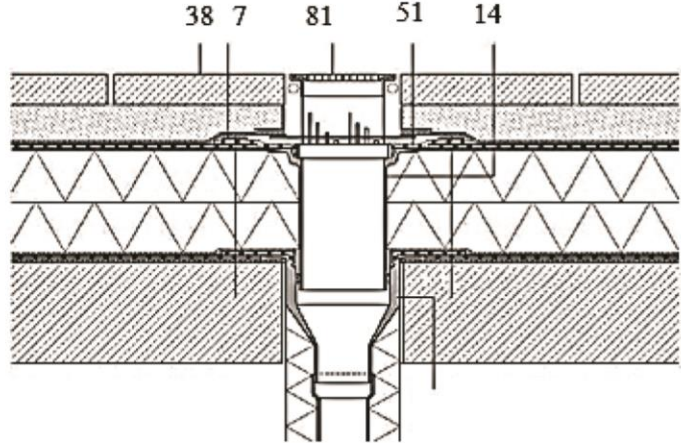

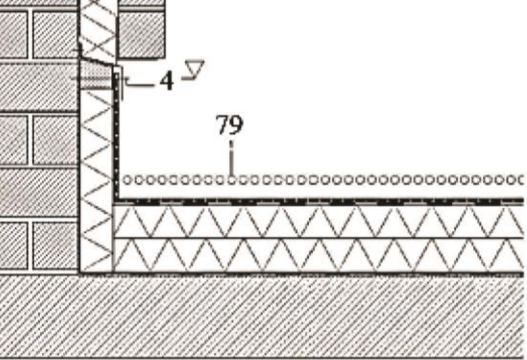
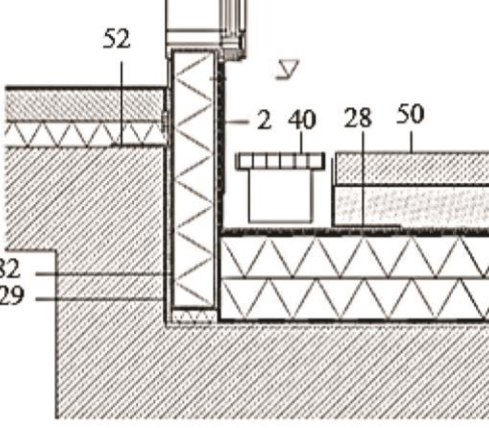
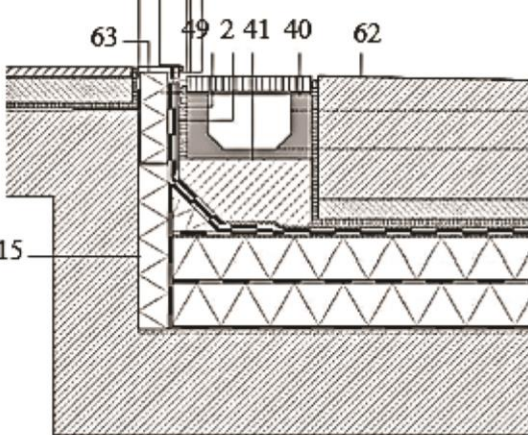

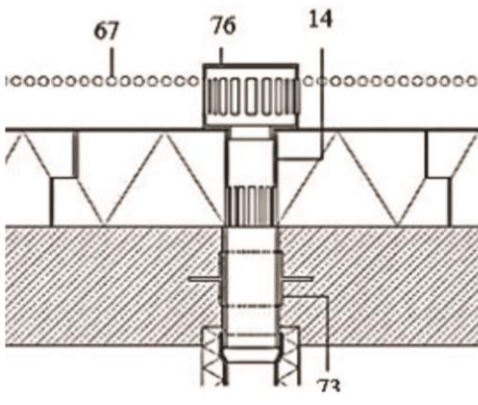
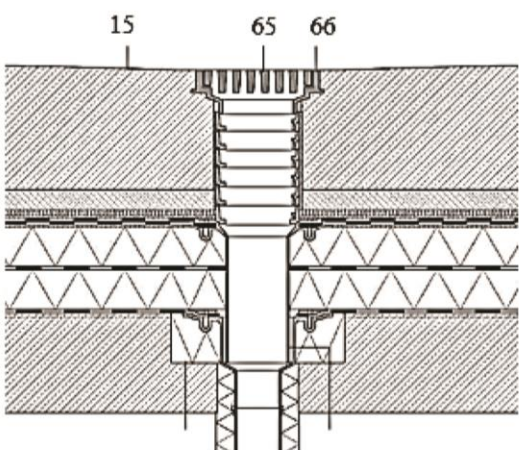
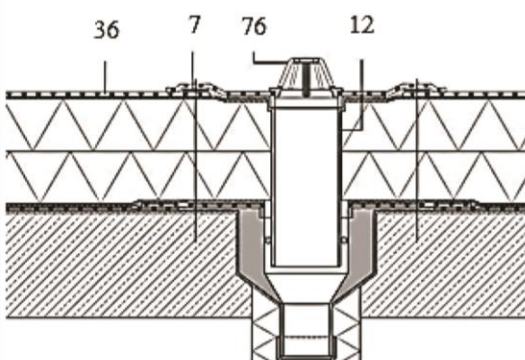

Flat Roof		Common Roof Defects and Suggestions for Flat Roofs in North Cyprus		
<p>Problem: Improper slope to the drain</p> 	<p>Reason of Problem</p> <p>Reason: Improper slope to the drains causes improper drainage</p> 	<p>Suggestion 1 (Flat roof with impermeable concrete)</p> 	<p>Suggestion 2 (Roof for vehicular traffic)</p> 	<p>Suggestion 3 (Water proofing above insulation)</p> 
<p>Problem: Improper joint between roof and parapet wall</p> 	<p>Reason of Problem</p> <p>Reason: Improper detailing causes ridging and cockling in the joint of roof to the parapet</p> 	<p>Suggestion 1 (Water proofing above insulation)</p> 	<p>Suggestion 2 (Water proofing above insulation)</p> 	
<p>Problem: Lack of thermal insulation</p> 	<p>Reason of Problem</p> <p>Reason: Lack of thermal insulation causes condensation and mold growth under roof</p> 	<p>Suggestion 1 (Proper detail for thermal comfort)</p> 	<p>Suggestion 2 (Proper detail for thermal comfort)</p> 	<p>Suggestion 3 (Proper detail for thermal comfort)</p> 

Table 22. Discussions and suggestions for common flat roof defects in North Cyprus (Suggestions from Schunck, 2010)

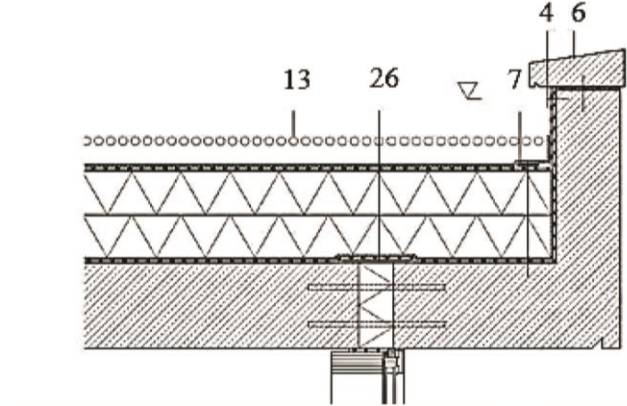
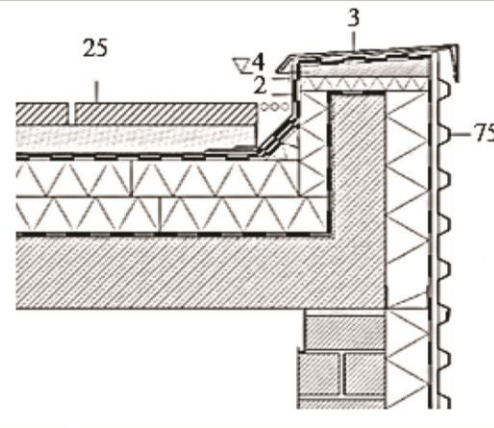



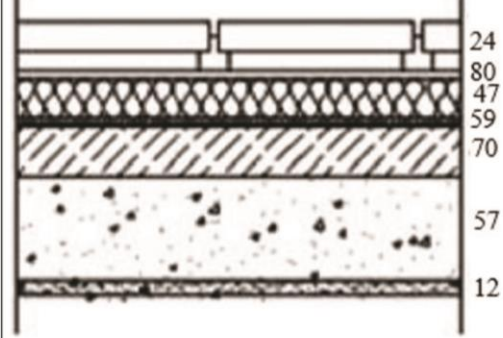

Flat Roof		Common Roof Defects and Suggestions for Flat Roofs in North Cyprus		
<p>Problem: Lack of coping</p> 	<p>Reason of Problem</p> <p>Reason:</p> <p>Lack of coping causes water penetration to the external walls</p> 	<p>Suggestion 1 (Roof for vehicular traffic)</p> 	<p>Suggestion 2 (with impermeable concrete)</p> 	<p>Suggestion 3 (metal roof)</p> 
<p>Problem: Improper wall to roof joints</p> 	<p>Reason of Problem</p> <p>Reason:</p> <p>Poor wall to roof joining detail</p> 	<p>Suggestion 1 (metal roof)</p> 	<p>Suggestion 2 (with impermeable concrete)</p> 	
<p>Problem: Improper drainage</p> 	<p>Reason of Problem</p> <p>Reason:</p> <p>Improper drain pipes</p> 	<p>Suggestion 1 (waterproofing above insulation)</p> 	<p>Suggestion 2 (for foot traffic)</p> 	<p>Suggestion 3 (with impermeable concrete)</p> 

Table 23. Discussions and suggestions for common flat roof defects in North Cyprus (Suggestions from Schunck, 2010)



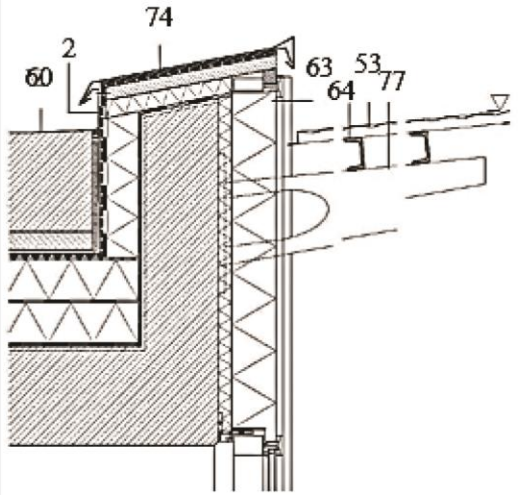
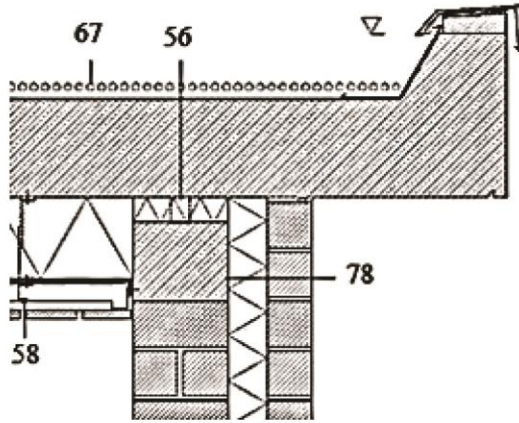
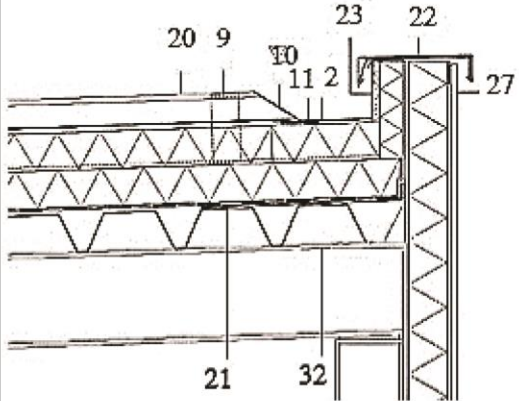

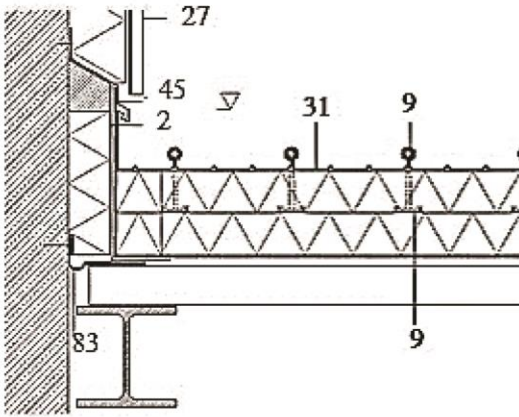
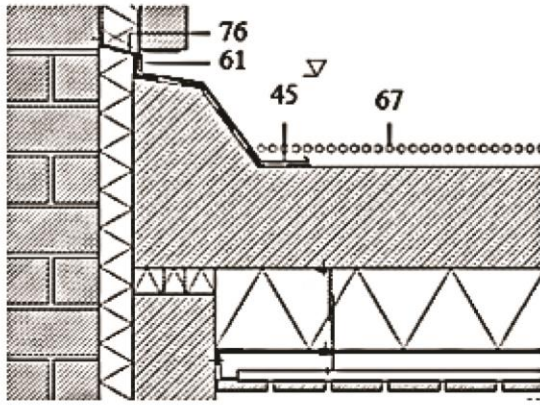

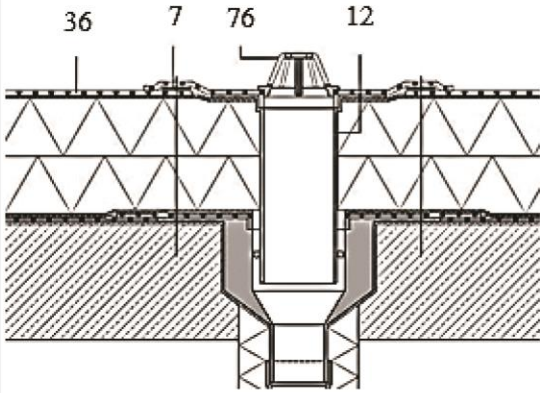
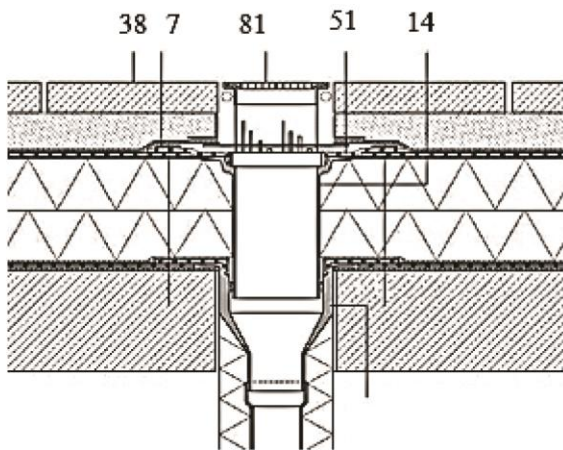
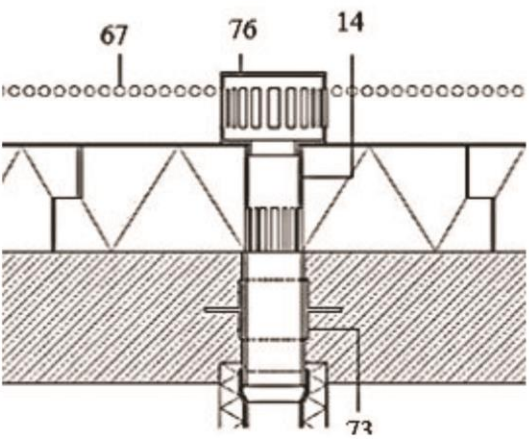
Flat Roof		Common Roof Defects and Suggestions for Flat Roofs in North Cyprus		
<p>Problem: Lack of coping</p> 	<p>Reason of Problem</p> <p>Reason: Improper coping causes water penetration</p> 	<p>Suggestion 1 (metal roof)</p> 	<p>Suggestion 2 (metal roof)</p> 	<p>Suggestion 3 (metal roof)</p> 
<p>Problem: Improper drainage</p> 	<p>Reason of Problem</p> <p>Reason: The rainwater drips over external walls</p> 	<p>Suggestion 1 (waterproofing above insulation)</p> 	<p>Suggestion 2 (for foot traffic)</p> 	
<p>Problem: Water stains on parapet</p> 	<p>Reason of Problem</p> <p>Reason: Water stains are demonstrating water penetration</p> 	<p>Suggestion 1 (waterproofing above insulation)</p> 	<p>Suggestion 2 (impermeable concrete)</p> 	<p>Suggestion 3 (for vehicular traffic)</p> 

Table 24. Discussions and suggestions for common flat roof defects in North Cyprus (Suggestions from Schunck, 2010)



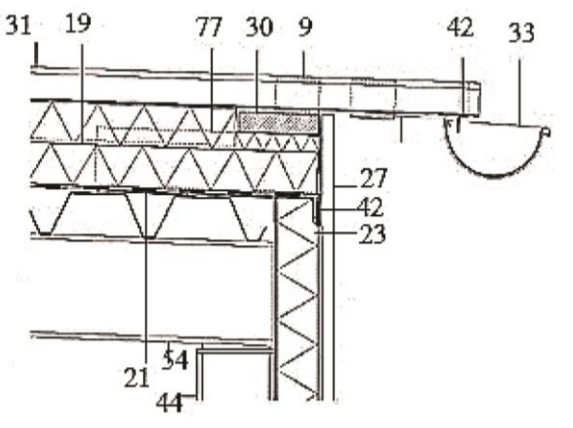
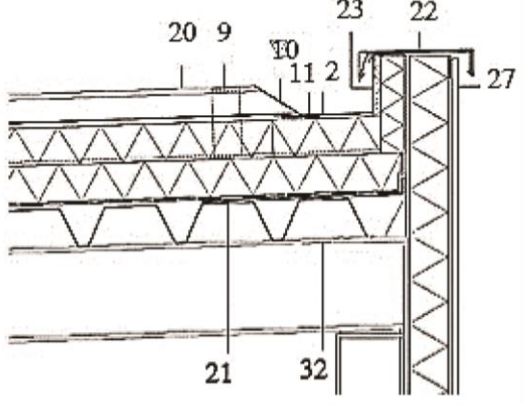
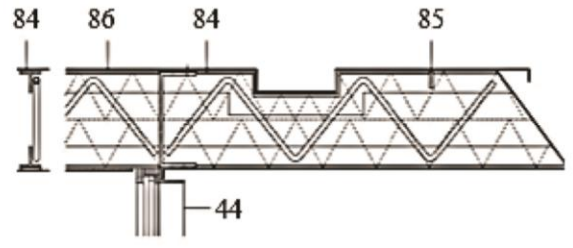

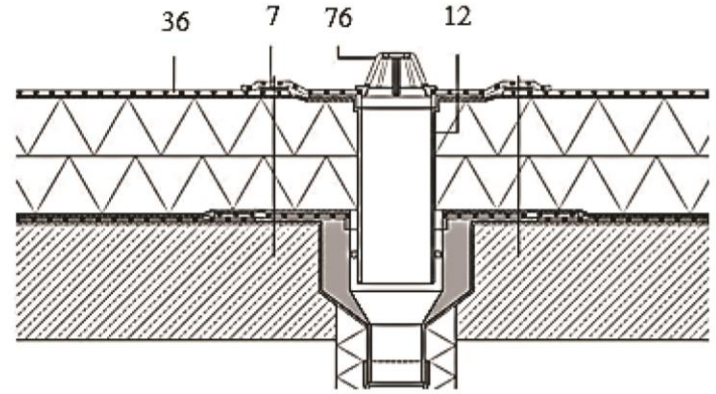
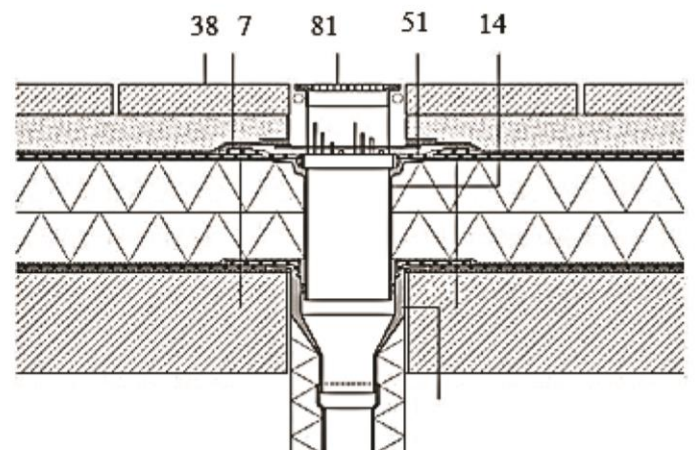

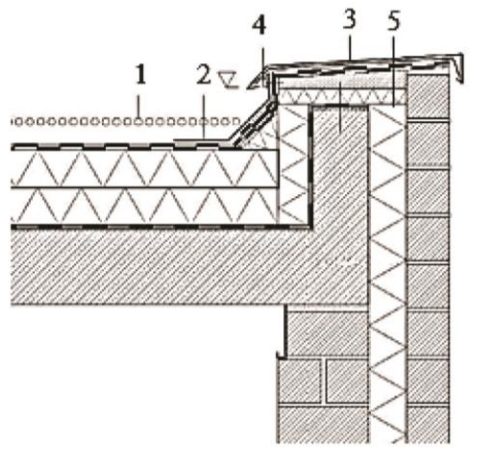
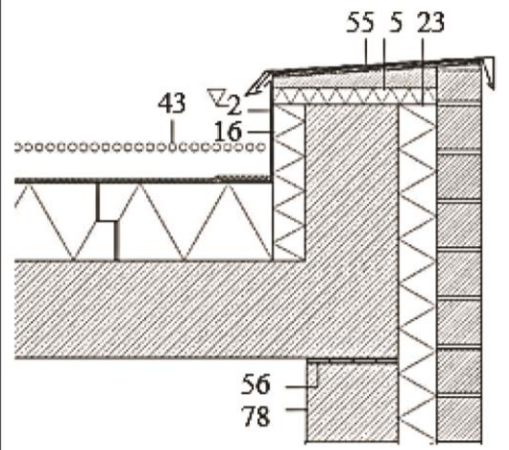
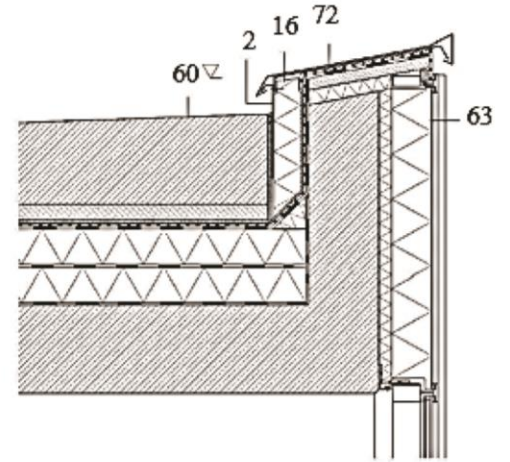
Flat Roof	Common Roof Defects and Suggestions for Flat Roofs in North Cyprus			
<p>Problem: Poor coping</p> 	<p>Reason of Problem</p> <p>Reason:</p> <p>Improper waterproofing of parapet wall</p> 	<p>Suggestion 1 (waterproofing above insulation)</p> 	<p>Suggestion 2 (impermeable concrete)</p> 	<p>Suggestion 3 (for vehicular traffic)</p> 
<p>Problem: Improper connection between roof and wall</p> 	<p>Reason of Problem</p> <p>Reason:</p> <p>Improper overhanging roof detail</p> 	<p>Suggestion 1 (metal roof)</p> 	<p>Suggestion 2 (metal roof)</p> 	
<p>Problem: Improper joint</p> 	<p>Reason of Problem</p> <p>Reason:</p> <p>Improper joints between roof and other elements</p> 	<p>Suggestion 1 (waterproofing above insulation)</p> 	<p>Suggestion 2 (for foot traffic)</p> 	<p>Suggestion 3 (for vehicular traffic)</p> 

Table 25. Discussions and suggestions for common flat roof defects in North Cyprus



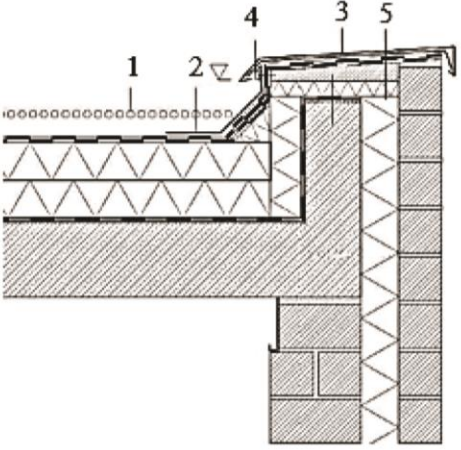
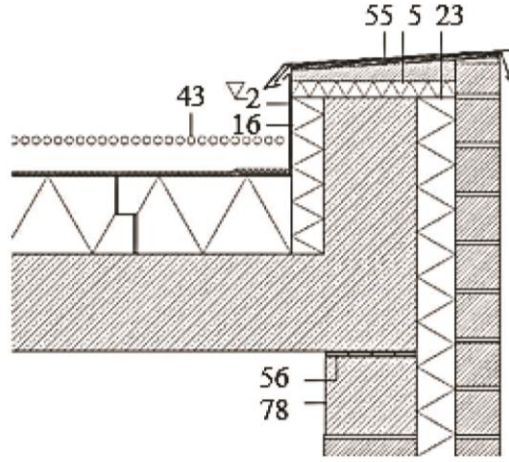
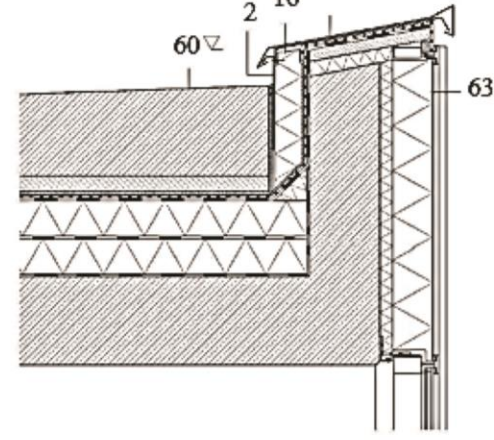

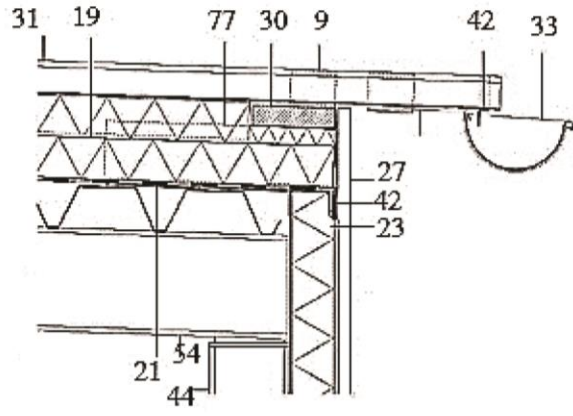
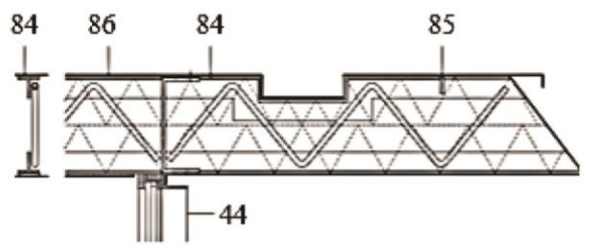

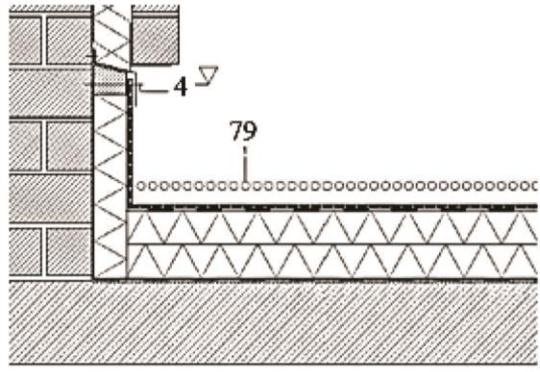
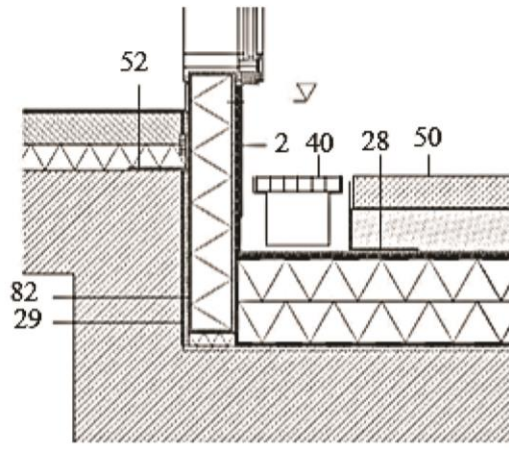
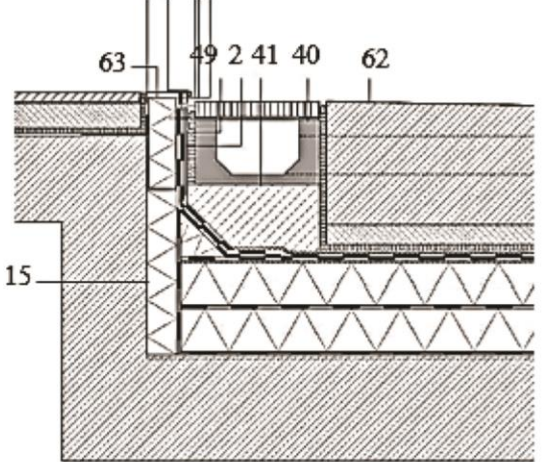
Flat Roof	Common Roof Defects and Suggestions for Flat Roofs in North Cyprus				
Problem: Splits on roofing membrane	Reason and Suggestions of Problem	Problem: Various elements block water falls	Reason and Suggestions of Problem	Problem: Roofing membrane is being punched with various elements	Reason and Suggestions of Problem
	<p>Reason:</p> <p>Improper workmanship results in splits on the roofing membrane of flat roofs</p> <p>The construction workers should be informed to build properly</p>		<p>Reason:</p> <p>Placing various elements over roof blocks the rainwater falls and causes ponding</p> <p>The surface of roof should be free of additional elements</p>		<p>Reason:</p> <p>Placing various elements over roof affects the appearance negatively</p> <p>The roof surface should become clear of additional elements</p>
Problem: Lap or joint failure	Reason and Suggestions of Problem	Problem: Improper roofing	Reason and Suggestions of Problem	Problem: Ridging and cockles on roofing membrane	Reason and Suggestions of Problem
	<p>Reason:</p> <p>Improper lap between roofing layers</p> <p>The construction workers should be informed to build properly</p>		<p>Reason:</p> <p>Improper roofing layers</p> <p>The construction workers should be informed to build properly</p>		<p>Reason:</p> <p>Ridging and cockles over roofing membrane affects its performance</p> <p>The construction workers should be informed to build properly</p>

Table 26. Guide for tables 20 to 25 (Schunck, 2010 and Özdeniz & Hanger, 2005)

1.	Loose gravel Bitumen waterproofing, 2ply Rigid plastic foam board Vapor barrier Primer Reinforced concrete	13.	Loose gravel Protective membrane Synthetic waterproofing Protective membrane Rigid plastic foam board Protective membrane Vapor barrier, RC	25.	Stone flags Chippings Protective membrane Bitumen waterproofing, 2ply Rigid plastic foam board Vapor barrier Primer Reinforced concrete	36.	Synthetic waterproofing Protective membrane Rigid plastic foam board Protective membrane Vapor barrier Protective membrane Reinforce concrete	48.	Concrete flags Chippings Filter fleece Extruded polystyrene (XPS) board Separating membrane Synthetic water proofing Protective membrane Screed laid to falls Extruded polystyrene (XPS) board	60.	Reinforced concrete slab laid to falls Screed Incompressible acoustic board Synthetic waterproofing Polymer-modified bitumen waterproofing Composite waterproofing:cellular glass. 2layers, bounded with bitumen Bitumen waterproofing Reinforced concrete	72.	Parapet capping Sheet metal clip Synthetic waterproofing Polymer-modified bitumen waterproofing Timber board Rigid plastic foam board	84.	R-girder (lattice beam)
2.	Sheet metal skirting	14.	Extension piece	26.	Bridging plate	37.	Precast concrete coping	49.	Acoustic blanket	61.	Elastic sealing tape	73.	Waterstop flange	85.	Stiffner
3.	Paraper capping Sheet metal clip Bitumen waterproofing, 2ply Timber board Rigid plastic foam board	15.	Rigid plastic foam board Reinforced concrete slab laid to falls Screed Incompressible acoustic board Protective membrane Bitumen waterproofing, 2ply Separating membrane Composite waterproofing: cellular glass, 2layerd, bounded with bitumen		38.	Concrete flags Chippings Protective membrane Synthetic waterproofing Separating membrane Rigid plastic foam board Separating membrane Vapor barrier Separating membrane Reinforced concrete	50.	Concrete flags Chippings Protective membrane Liquid waterproofing Bitumen facing Rigid plastic foam board Vapor barrier Primer Reinforced concrete	62.	Reinforce concrete slab laid to falls Screed Incompressible acoustic board Liquid waterproofing Synthetic waterproofing Composite waterproofing: cellular glass, 2layers, bounded with bitumen Vapor barrier Primer. RC	74.	Parapet capping Sheet metal clip Liquid waterproofing Timber board Rigid plastic foam board	86.	Galvanized sheet steel Mineral fiber board Galvanized sheet steel	
4.	Clamping bar	16.	Extruded Polystyrene (XPS)board	27.	Trapezoidal profile metal cladding	39.	Grating for foot traffic	51.	Collar of synthetic waterproofing	63.	Insulated panel	75.			Trapezoidal profile metal cladding Facing Mineral fiber board
5.	Rigid plastic foam board	17.	Laminated safety glass	28.	Mesh to prevent loss of chippings	40.	Drainage channel	52.	Fixing angle	64.	Load bearing member	76.			Dome grating
6.	Precast concrete coping	18.	Sheet metal sill	29.	Acoustic board	41.	Permeable in situ concrete	53.	Wire mesh	65.	Cast iron grating	77.			Bracket
7.	Linear fixing	19.	Mounting rail	30.	Eaves board	42.	Preformed sealing strip	54.	Beam	66.	Grating frame	78.			Ring beam
8.	Vapor barrier Primer Reinforced concrete	20.	Aluminum standing seam sheets Mineral fiber board, 2layers, top layer incombustible, bottom layer incompressible Vapor barrier Trapezoidal profile sheets Load bearing section	31.	Profiled metal sheet Mineral fiber board, 2layers, bottom layer incompressible Vapor barrier Trapezoidal profile sheet	43.	Loose gravel Filter fleece Extruded polystyrene (XPS) board Impermeable concrete slab	55.	Parapet capping Sheet metal clipp Protective membrane Timber board	67.	WU-Impermeable concrete slab Mineral fiber board Smart vapor barrier	79.			Loose gravel Liquid waterproofing Facing Rigid plastic foam board Vapor barrier Primer Reinforced concrete
9.	Clip for standing seam	21.	Sheet metal covering to throughs	32.	Stiffened sheet metal capping	44.	Column	56.	Slip plane	68.	Pebble 3cm	80.			Polymeric bituminous membrane water insulation
10.	Weld seam	22.	Parapet capping Sheet metal clip	33.	Gutter	45.	Cover flashing	57.	Reinforced concrete slab	69.	Felt	81.			Grating for foot traffic
11.	Protective membrane	23.	Mineral fiber board	34.	Gutter bracket	46.	Stiffener	58.	Grid to support suspended ceiling Suspended ceiling	70.	Leveling concrete 4-6 cm	82.	Panel filled with cellular glass		
12.	Gypsum plaster	24.	Terrazzo 4 cm	35.	Timber lath 2.5cm	47.	Extruded polystyrene heat insulation, 4cm	59.	Vapor retarder	71.	Hard glass wool, 4cm	83.	Sealing strip		

Table 27. Discussions and suggestions for common pitched roof defects in North Cyprus (Suggestions from Schunck & Oster, 2003 and Özdeniz & Hançer, 2005)





Pitched Roof		Common Roof Defects and Suggestions for Pitched Roofs in North Cyprus		
Problem: Poor details	Reason of Problem	Suggestion 1 (Profiled clay and concrete tiles: Roof covering with secondary waterproofing layer underneath)	Suggestion 2 (Sheet metal roof covering: Roof covering on sheathing and roof decking, ventilated thermal insulation and vapor barrier)	Suggestion 3 (roof detail for thermal satisfaction)
	Reason: broken tiles and improper roof detailing ➔			
Problem: Water penetration, improper flashing	Reason of Problem	Suggestion 1 (waterproofing above insulation)		Suggestion 2 (roof detail for thermal satisfaction)
	Reason: Water penetration as a result of improper roof window detail ➔			
Problem: Poor eave detail	Reason of Problem	Suggestion 1 (Profiled clay and concrete tiles: Roof covering with secondary waterproofing layer underneath)	Suggestion 2 (Metal profiled sheeting: Ventilated roof covering, roofing felt on thermal insulation, loadbearing skin acting as vapor barrier)	Suggestion 3 (roof detail for thermal satisfaction)
	Reason: Poor valley detail ➔			

Table 28. Discussions and suggestions for common pitched roof defects in North Cyprus (Suggestions from Schunck & Oster, 2003)



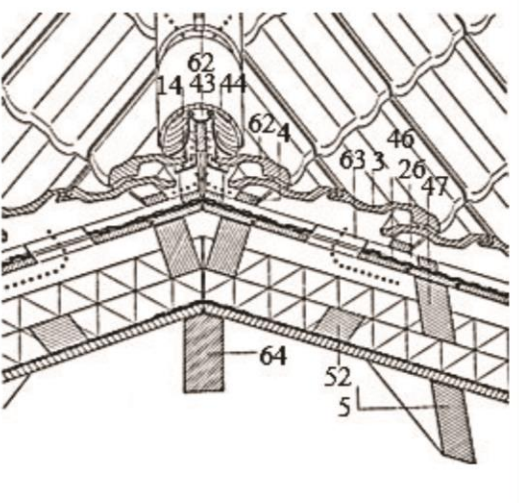
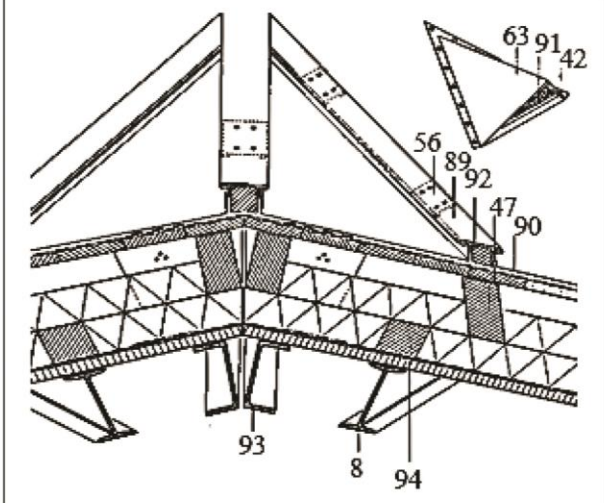
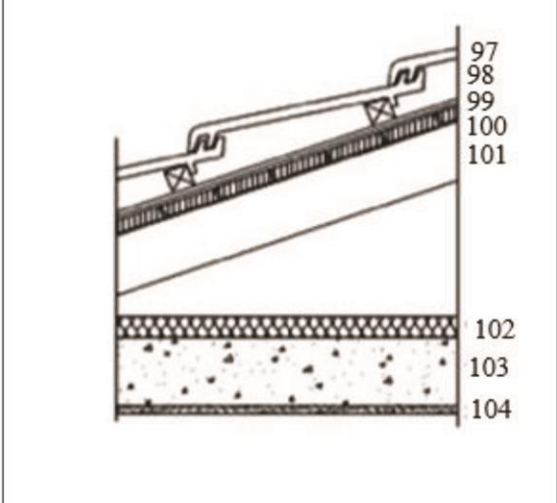

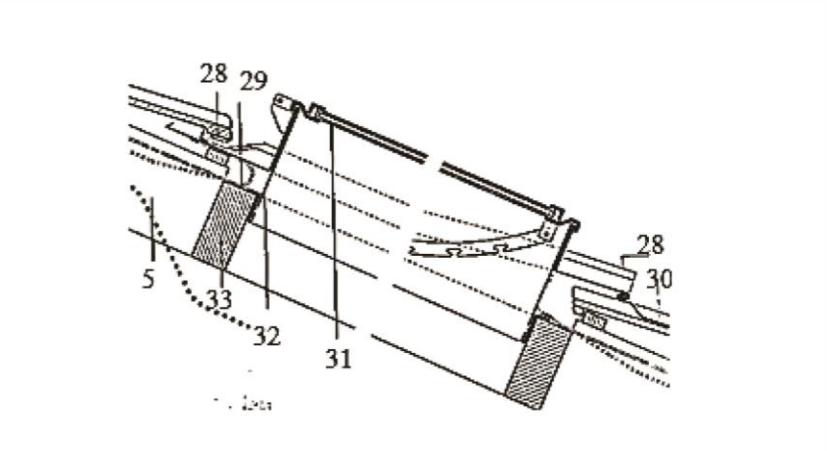
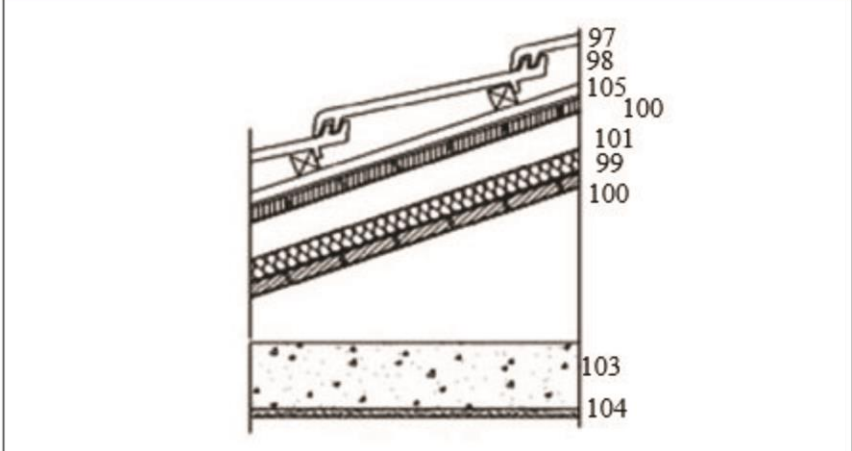
Pitched Roof		Common Roof Defects and Suggestions for Pitched Roofs in North Cyprus		
Problem: Poor drainage	Reason of Problem	Suggestion 1 (Profiled clay and concrete tiles: Roof covering with secondary waterproofing layer underneath)	Suggestion 2 (Metal profiled sheeting: Ventilated roof covering, roofing felt on thermal insulation, loadbearing skin acting as vapor barrier)	Suggestion 3 (Profiled clay and concrete tiles: Roof covering over open roof space)
	Reason: Lack of gutter ➔			
Problem: Poor valley detail	Reason of Problem	Suggestion 1 (Profiled clay and concrete tiles: Roof covering over open roof space)	Suggestion 2 (Metal profiled sheeting: Ventilated roof covering, roofing felt on thermal insulation, loadbearing skin acting as vapor barrier)	
	Reason: Improper valley detail ➔			
Problem: Poor dormer detail	Reason of Problem	Suggestion 1 (Profiled clay and concrete tiles: Roof covering with roofing felt underneath)	Suggestion 2 (Profiled clay and concrete tiles: Roof covering with secondary waterproofing layer underneath)	Suggestion 3 (Metal profiled sheeting: Ventilated roof covering, roofing felt on thermal insulation, loadbearing skin acting as vapor barrier)
	Reason: Improper roof to dormer connection ➔			

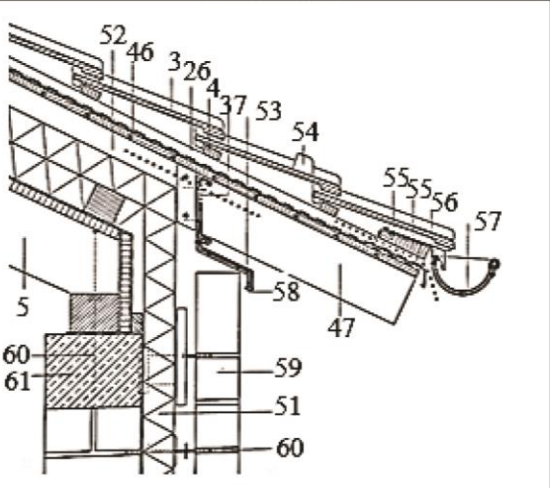
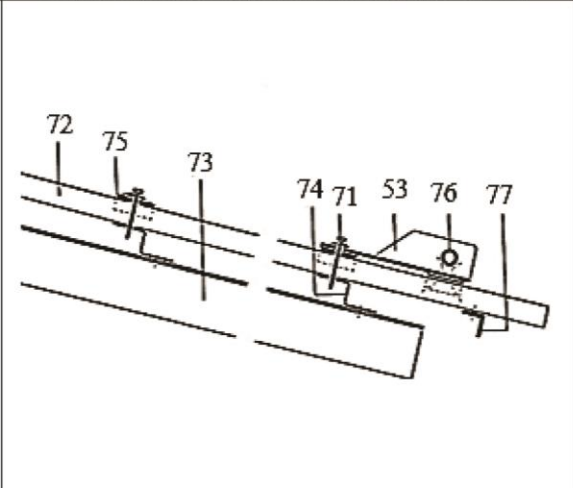
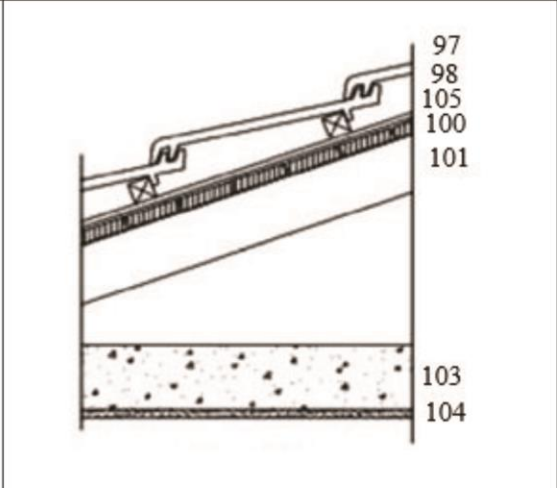
Table 29. Discussions and suggestions for common pitched roof defects in North Cyprus (Suggestions from Schunck & Oster, 2003 and Özdeniz & Hançer, 2005)



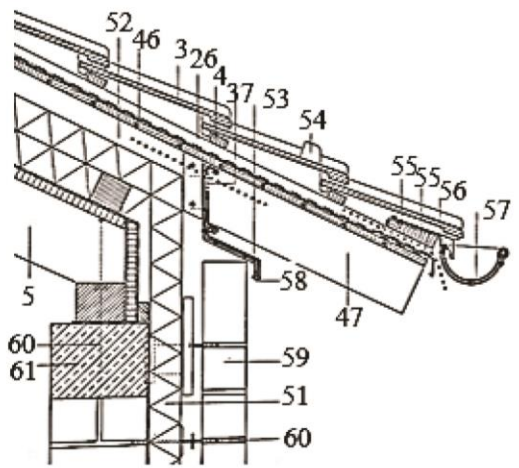
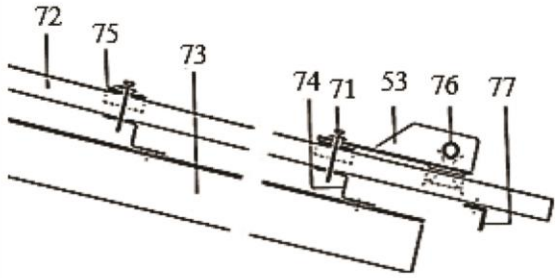
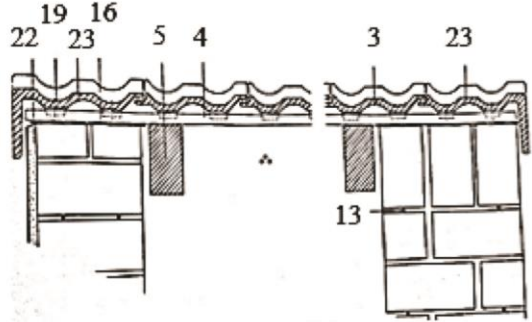

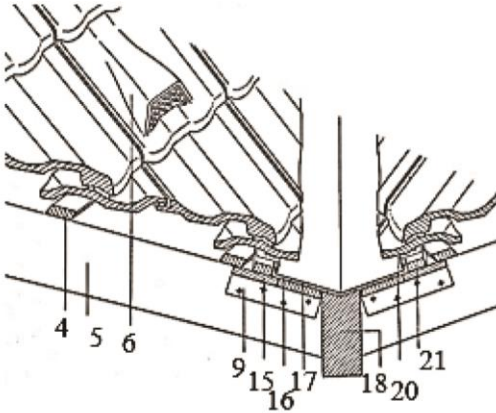
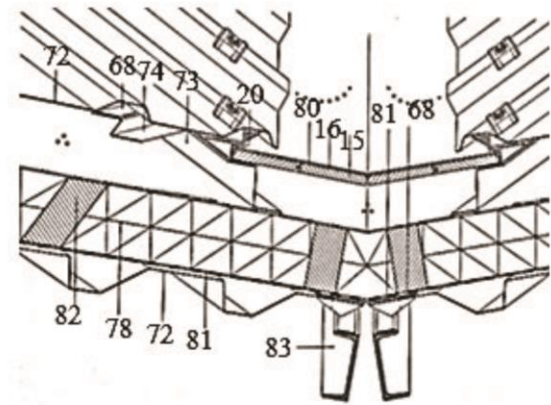
Pitched Roof		Common Roof Defects and Suggestions for Pitched Roofs in North Cyprus	
Problem: Improper drainage	Reason of Problem	Suggestion 1 (Sheet metal roof covering: Roof covering on sheathing and roof decking, ventilated thermal insulation and vapor barrier)	
	Reason: Rainwater drips over external walls ➔		
Problem: Poor dormer and roof connection	Reason of Problem	Suggestion 1 (Profiled clay and concrete tiles: Roof covering with roofing felt underneath)	Suggestion 2 (Profiled clay and concrete tiles: Roof covering with secondary waterproofing layer underneath)
	Reason: Improper roof to dormer connection ➔		
Problem: Poor chimney connection	Reason of Problem	Suggestion 1 (Profiled clay and concrete tiles: Roof covering with roofing felt underneath)	Suggestion 2 (roof detail for thermal satisfaction)
	Reason: Improper penetration detail ➔		

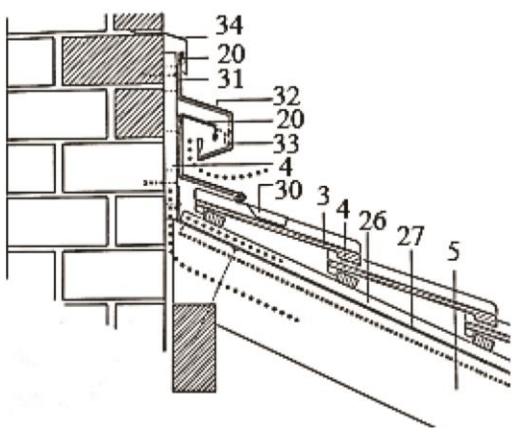
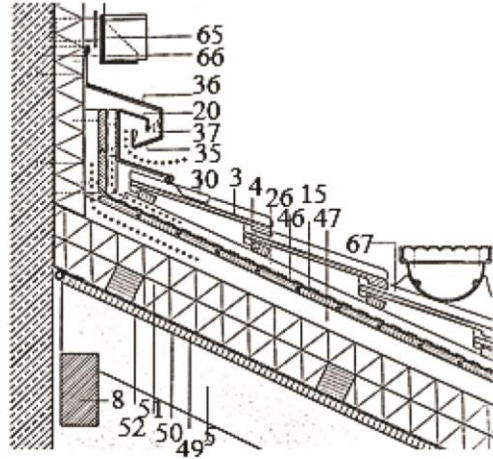
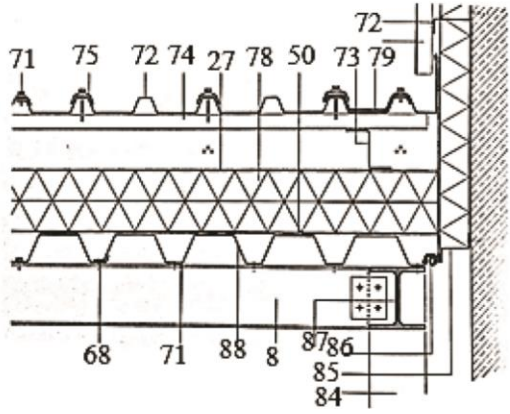
Table 30. Discussions and suggestions for common pitched roof defects in North Cyprus (Suggestions from Schunck & Oster, 2003)



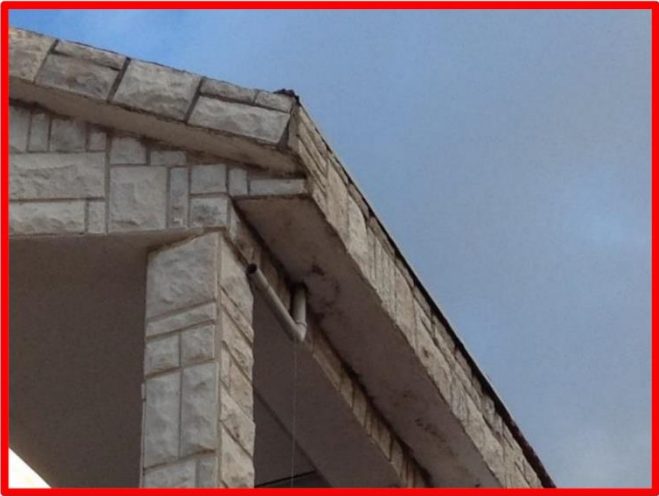
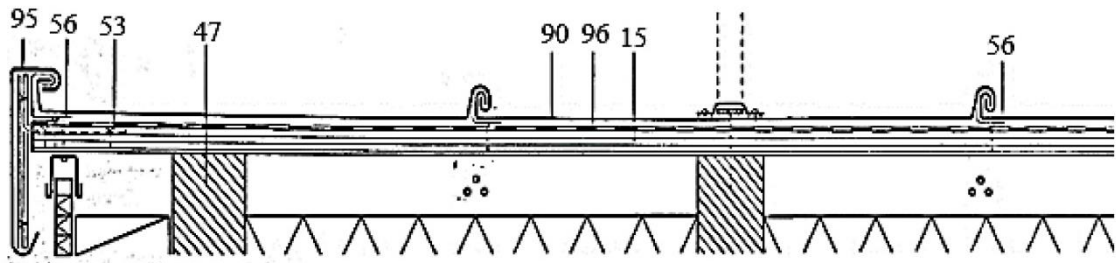

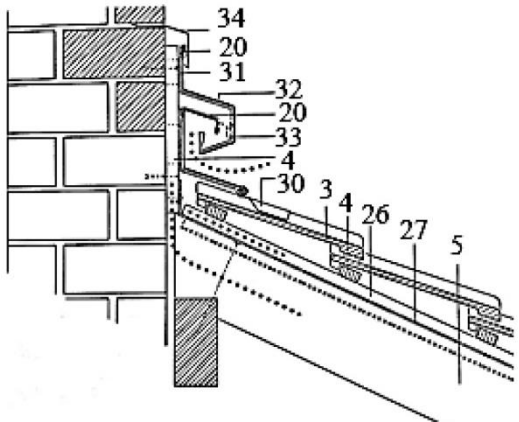
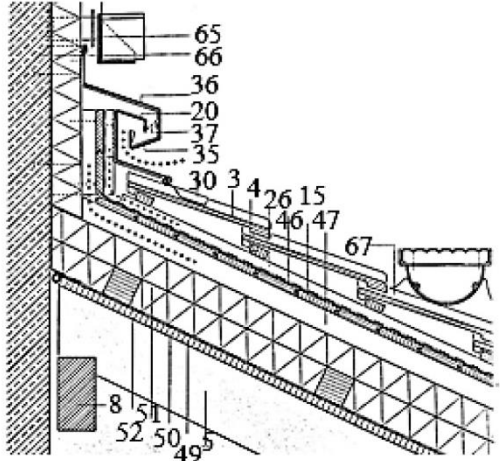

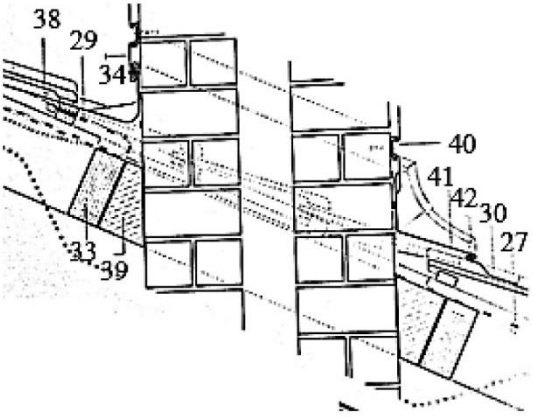
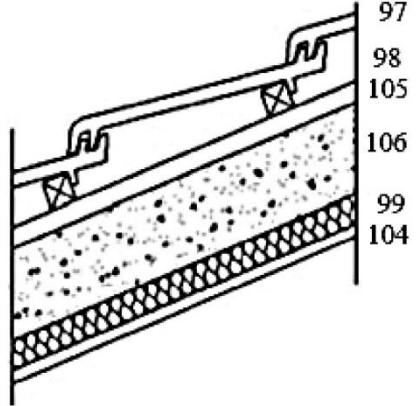
Pitched Roof		Common Roof Defects and Suggestions for Pitched Roofs in North Cyprus		
<p>Problem: Poor ridge detail</p> 	<p>Reason of Problem</p> <p>Reason: Improper ridge detail</p> 	<p>Suggestion 1 (Profiled clay and concrete tiles: Roof covering over open roof space)</p> 	<p>Suggestion 2 (Profiled clay and concrete tiles: Roof covering with roofing felt underneath)</p> 	<p>Suggestion 3 (Profiled clay and concrete tiles: Roof covering with secondary waterproofing layer underneath)</p> 
<p>Problem: Poor ridge detail</p> 	<p>Reason of Problem</p> <p>Reason: Improper ridge detail</p> 	<p>Suggestion 1 (Metal profiled sheeting: Ventilated roof covering, roofing felt on thermal insulation, loadbearing skin acting as vapor barrier)</p> 	<p>Suggestion 2 (Sheet metal roof covering: Roof covering on sheathing and roof decking, ventilated thermal insulation and vapor barrier)</p> 	
<p>Problem: Poor drainage</p> 	<p>Reason of Problem</p> <p>Reason: Rainwater is not drained from each level of roof independently</p> 	<p>Suggestion 1 (Profiled clay and concrete tiles: Roof covering with secondary waterproofing layer underneath)</p> 	<p>Suggestion 2 (Metal profiled sheeting: Ventilated roof covering, roofing felt on thermal insulation, loadbearing skin acting as vapor barrier)</p> 	<p>Suggestion 3 (Profiled clay and concrete tiles: Roof covering over open roof space)</p> 

Table 31. Discussions and suggestions for common pitched roof defects in North Cyprus



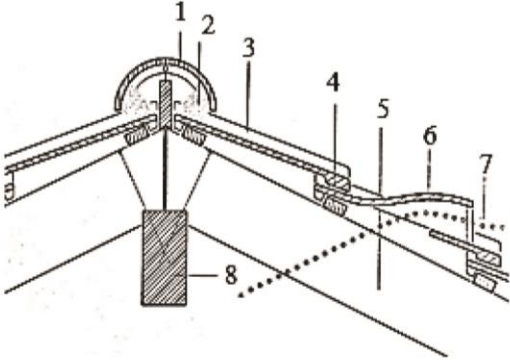
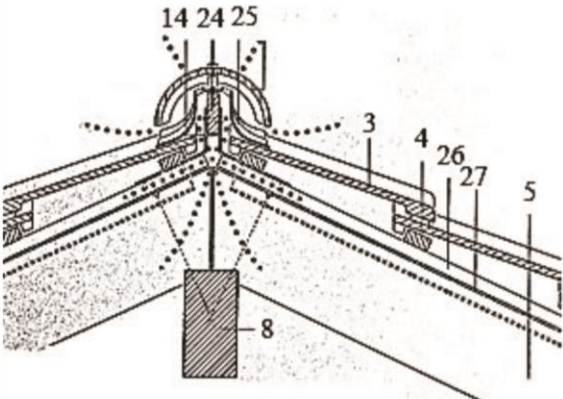
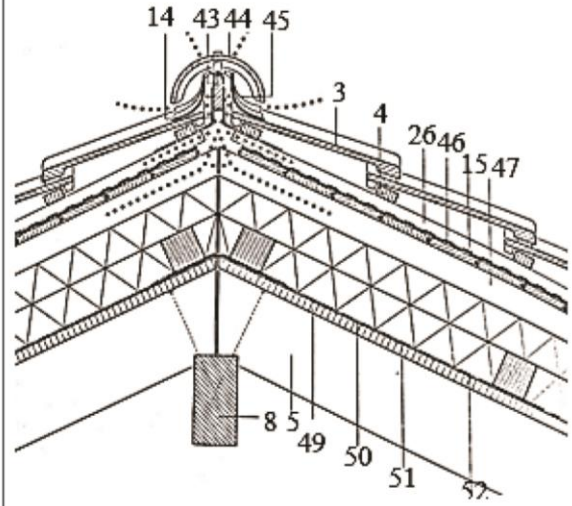

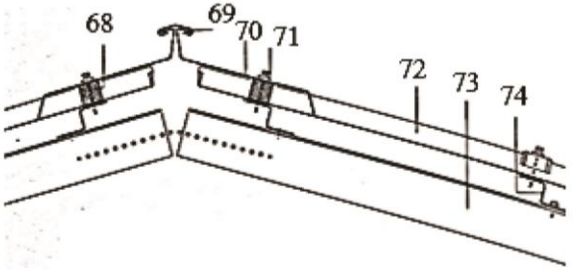
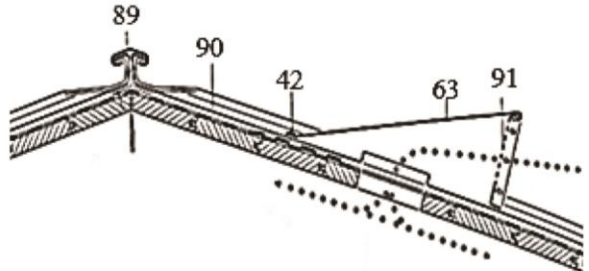

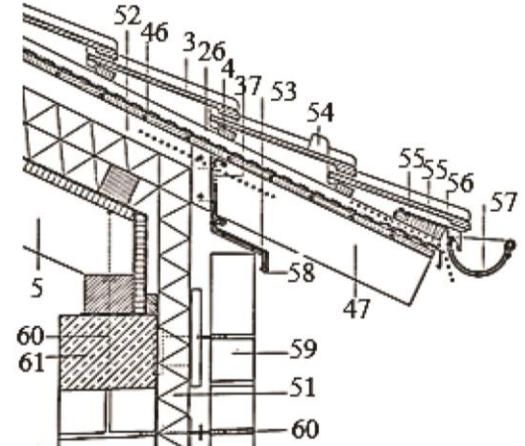
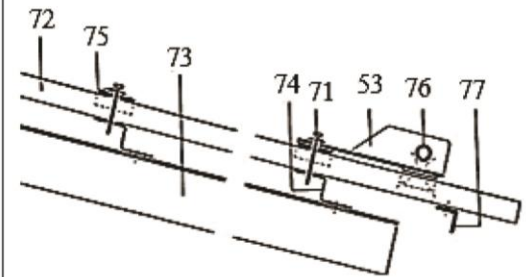
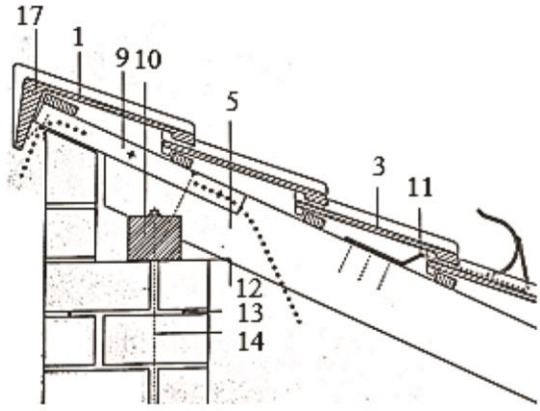
Flat Roof	Common Roof Defects and Suggestions for Flat Roofs in North Cyprus				
Problem: Vegetation and algae on roof tiles	Reason and Suggestions of Problem	Problem:Blocked gutter	Reason and Suggestions of Problem	Problem: Slipped and lost tiles	Reason and Suggestions of Problem
	<p>Reason:</p> <p>Vegetation and algae grow over the roof tiles</p> <p>Roof tiles should be cleaned</p>		<p>Reason:</p> <p>Blocked gutter causes improper drainage</p> <p>Gutters should be cleaned</p>		<p>Reason:</p> <p>Slipped and lost roof tiles as a result of poor workmanship and maintenance</p> <p>Tiles should be modified</p>
Problem: Slipped roof tiles	Reason and Suggestions of Problem	Problem: Placing various elements over roof	Reason and Suggestions of Problem	Problem: Mold on tiles	Reason and Suggestions of Problem
	<p>Reason:</p> <p>Slipped and lost roof tiles as a result of poor workmanship and maintenance</p> <p>Tiles should be modified</p>		<p>Reason:</p> <p>Placing various elements over roof affects the appearance and punches tiles</p> <p>The roof surface should be free from additional elements</p>		<p>Reason:</p> <p>Mold growth over tiles as a result of high humidity and lack of proper maintenance</p> <p>Roof tiles should be cleaned</p>

Table 32. Guide for tables 27 to 31 (Suggestions from Schunck & Oster, 2003 and Özdeniz & Hançer, 2005)

1.	Ridge/hip capping, mono ridge tile	18.	Hip/valley rafter	35.	Fixing for flashing	53.	Fixing for flashing ladder hook	70.	Apron flashing, cut and bent down to close off throughs	87.	Roof beam	104.	Gypsum plaster 0.5cm
2.	Mortar	19.	Wood screw	36.	Ventilation hood	54.	Snow guard tile	71.	Self-tapping screw	88.	Trapezoidal profile sheeting, loadbearing	105.	Polymeric bituminous membrane water insulation
3.	Interlocking profile tile	20.	Clip	37.	Mesh screen to ventilation opening	55.	Drip flashing	72.	Trapezoidal profile sheeting, roof covering	89.	Capping strip, verge capping	106.	Inclined reinforced concrete
4.	Batten	21.	Valley batten	38.	Back gutter	56.	Clip, continous clip	73.	Spacer section	90.	Sheet metal roof covering		
5.	Rafter	22.	Rendering	39.	Concrete	57.	Gutter and bracket	74.	Sheeting rail	91.	Mesh screen		
6.	Ventilating tile	23.	Cloaked verge tile	40.	Stop bead	58.	Flashing	75.	Pressure and capping piece	92.	Batten roll		
7.	Mesh screed to ventilation opening	24.	Ridge/hip batten, tiling board	41.	Apron flashing	59.	Facing brickwork	76.	Tubular snowguard with ice stop	93.	Hip beam		
8.	Purlin	25.	Vent	42.	Rivet and solder	60.	Masonry anchor, wall tie in dovetail slot	77.	Rainwater drip	94.	Spacer purlin, hood support		
9.	Additional batten	26.	Counter batten	43.	Ridge/hip batten	61.	Capping beam	78.	Thermal insulation	95.	Verge flashing		
10.	Wall plate	27.	Roofing felt	44.	Ventilating ridge capping	62.	Interlocking profile tile, cut to suit	79.	Profiled apron flashing	96.	Shething (laide with laps), textured top surface		
11.	Gutter bracket, ladder hook, snowguard mounting	28.	Drain channel	45.	Ventilating element	63.	Vent	80.	Valley gutter	97.	Roof tile		
12.	Damp-proof course	29.	Foil channel	46.	Bitumen roofing felt, two layers	64.	Hip rafter	81.	Vapor barrier (sheet metal)	98.	Timber lath, 2.5 cm		
13.	Peripheral reinforcement (in bed joint or capping beam)	30.	Milled sheet lead flashing	47.	Spacer rafter	65.	Bracket	82.	Timber member	99.	Extruded polystyrene heat insulation, 4cm		
14.	Metal strap	31.	Single glazing	49.	Timber derivation board	66.	Anchor	83.	Valley beam	100.	Timber board, 2.5cm		
15.	Timber boarding	32.	Window frame	50.	Vapor barrier	67.	Step support tile with step	84.	Column	101.	Timber rafter, 5-10cm		
16.	Separating layer	33.	Trimmer	51.	Thermal insulation, two layers	68.	Sealing strip	85.	Z-section rail	102.	Soft glasswool heat insulation, 4cm		
17.	Sheet metal valley gutter	34.	Cover flashing	52.	Spacer purlin	69.	Ridge capping	86.	Permenantly elastic performed seal	103.	Reinforced concrete slab		

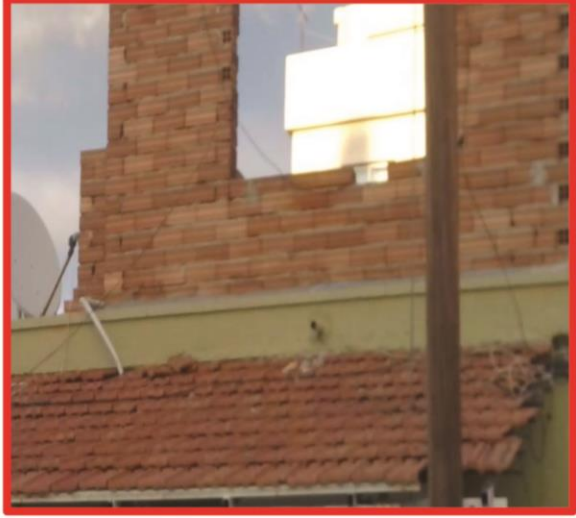
Chapter 4

CONCLUSION

Building defects have always imposed a great amount of expenditures to both users and constructors. Enhancing knowledge and information related to this subject can be utilized for precaution and remedy and it can be used to decrease the expenditures. A significant number of buildings face problems a few years after they are constructed. The importance of this problem can be fully comprehended when it is considered that all building elements are susceptible to defect. Roofs, as one of the major elements of the building envelope with high area in contact with the surrounding environment, also face problems.

In North Cyprus, after the development of Annan Plan, a great number of buildings were built in short amount of time. These buildings were often constructed with minimum costs and quality. Although there exist a number of rules, such as FASIL 96, in North Cyprus for construction of buildings and part of these rules and regulations are related to roof construction, a significant number of these buildings are observed to face severe problems. The same problem can be seen in all developing countries which have experienced a boom in the construction industry. Therefore, building with minimum costs and qualities are resulted.

Returning to the questions which are posed at the beginning, it can be concluded that there exist a various reasons for building defects. These reasons are directly related to

the function of a building element. Considering what Foster has mentioned as the function of a roof in 1994, this thesis has divided and evaluated roofs in five categories: form, structure, material, indoor air quality and thermal insulation and construction details.

A wide range of roof systems are applied all over the world from each of the above mentioned categories. The main aim of this categorization was to mention some of the existing roof systems and to compare them with roof construction in North Cyprus.

In order to study roof defects in North Cyprus, contemporary roof construction should be analyzed. Similar to how roofs were categorized in the previous sections, they were also divided into form, structure, material, indoor air quality and thermal insulation and construction details here. The results have shown that the application of roof system has a repeating format in North Cyprus and a wide variety of them are not implemented.

The forms of roofs in Nicosia are observed to be generally flat, especially in the newly built constructions. While for rural parts, a slight difference is observed between pitched and flat roof application. In Famagusta, flat roofs are often selected. In the more developed rural parts flat roofs are preferred, however; in most of the villages of the Famagusta district pitched roofs are slightly more than flat ones. The same analysis was done for Kyrenia district. The results have demonstrated that in rural parts a small difference exists between these two forms of roofs, while in the rural part pitched roofs are significantly more than flat ones. In contrast to what was observed in Kyrenia, in Iskele pitched roofs are more in the urban parts, however; in villages flat roofs are often preferred.

The roof structures are also categorized by considering forms. For example for flat roofs, reinforced concrete is the most preferred structure and steel ones are rarely selected. While for pitched roofs, inclined reinforced concrete and standing timber roofs are common. In some cases for especial functions such as factories and stores, pitched steel roofs are chosen. For residential buildings the latter two structures are implemented and the constructors are hesitate to apply steel materials.

The materials which are used for construction are also repeated in most of the cases. Reinforced concrete, timber and steel are applied as the structure of roof; while for thermal insulation polystyrene and glass wool are the preferred materials. For waterproofing layer, bituminous is applied and also bituminous with polystyrene felt performs as the roofing layer in flat roof construction. Clay tiles are often the finishing layer of pitched roof in North Cyprus. For gutters, galvanized steel is generally used together with plastic pipes. Pvc pipes and gutters are also observed in some cases. Sandwich panels are implemented with steel structures as covering layers and insulations.

From indoor air quality and thermal insulation point of view, it should be mentioned that most of the buildings in North Cyprus are constructed without any thermal insulations. When thermal insulation is applied, the position differs from case to case. In most of the existing details, as a result of using reinforced concrete, the resistance to fire is guaranteed to some extent. Reinforced concrete's resistance does not fall until very high temperatures; however its resistance differs with the amount of reinforcement. As a result of lack of precise and proper details during the design process, the air-tightness and moisture movement are not in a satisfying level.

By analyzing the construction details of roofs in Northern Cyprus it is now possible to conclude that, the details are highly similar for each roof form. The application of similar materials and orders has caused repeated details. Flat roofs are generally constructed without thermal insulation with bitumen felt roofing and reinforced concrete slabs. The pitched roofs are not often ventilated and built without thermal insulation (when thermal insulation is applied, it is located on the reinforced concrete slab or the inclined layer). Beneath clay tiles, the bituminous waterproofing layer is commonly used.

The evaluation of roofs in North Cyprus according to the owners, 5-6 years after occupation has demonstrated that most of them are not satisfied with the current conditions of roof systems in Northern Cyprus. The form of roofs which users prefer are hipped and duo-pitched ones, however; the application of flat roofs are increasing day by day as a result of lower costs and the ease of construction.

Additionally, the constructors were asked to evaluate roof systems in North Cyprus. Although more than half of them believed that roof construction is in a satisfying level in North Cyprus, they have counted various problems as the existing roof defects. When their preferred roof type is asked from the constructors, most of them have selected flat reinforced concrete roofs.

Roof defects are also asked from the users and constructors. Users believe that thermally uncomfortable conditions, heat flow, drainage and appearance are the most important roof defects in North Cyprus; while constructors have mostly selected drainage, sanitation, resistance to heat flow, thermal comfort, quality and air-tightness.

In the next step, the designed and constructed projects are compared with the existing International Building Codes. The evaluated criteria are weather resistance, performance requirements, air barrier, ventilation, moisture control, drainage, thermal insulation, position of thermal insulation, roof tiles, roofing membrane, leveling and appearance. The resulted problems are shown in the following table together with the causing root of each criteria. The roots are divided into design, construction and maintenance. [Table 33]

Table 33. The causing roots of roof defects in North Cyprus

Criteria	Design	Construction	Maintenance
Weather Resistance	•	•	
Performance Requirements	•		
Air Barrier	•	•	
Ventilation	•		
Moisture Control		•	
Drainage	•	•	•
Thermal Insulation	•		
Position of Thermal Insulation	•		
Roof Tiles	•	•	•
Roofing Membrane		•	•
Leveling	•	•	
Appearance		•	•

Part of the defects which are related to the design process are 1. Lack of precise and proper design details 2. Lack of application of thermal insulations 3. Lack of copping and DPCs for the parapet walls 4. Lack of proper sloping for flat roofs 5. Improper design of drain pipes and drainage system 6. Poor flashing and penetration details 7. Poor roof to wall and parapet wall connection details

Other problems are related to poor workmanship and construction. 1. Ridging and cockles over the roofing membrane 2. Roofing joint failure 3. Poor leveling 4. Splits on roofing 5. Slipped and loose tiles.

The third category of roof problem in North Cyprus is originated from the poor maintenance. 1. Placing various elements over the roof and blocking rainwater results in ponding and improper drainage. This problem also results in punched roofing membrane 2. Mold, algae and vegetation over roof tiles 3. Loose or slipped roof tiles should be changed and modified otherwise it causes other roof defects. 4. Blocked and broken gutters results in improper drainage 5. Placing water store tanks and solar panels over roof negatively affects its appearance.

Similar to any other research, this thesis also faced various limitations. The limited time of this research has forced the author to focus on a specified case which is Northern Cyprus. The results should be different for other cases related to their climatic conditions.

Additionally, the aim of this thesis was to analyze contemporary roof defects, for this reason; historic buildings become out of the scope of this research and roofs which are less than 20 years old are analyzed.

During the data collection process, the number of companies which were available and wanted to participate in the research were limited. Only 20 companies participated and others ignored to help or did not work at the time when the data was collected. Further researches can be conducted to deal with these limitations or to diagnose the reason of roof defects in other cases.

REFERENCES

- Abdul-Rahman, H., Wang, C., Wool, L. C., & Khoo, Y. M. (2014). Defects in Affordable Housing Projects in Klang Valley, Malaysia. *Journal of Performance of Constructed Facilities*, 28, 272-285.
- Ahzahar, N., Karim, N. A., Hassan, S. H., & Eman, J. (2011). A Study of Contribution Factors to Building Failures and Defects in Construction Industry. *Procedia Engineering*, 20, 249-255.
- Alibaba, H. Z. (2003). An expert system for the selection of building elements during architectural design (Unpublished doctoral dissertation). Eastern Mediterranean University, North Cyprus.
- Alibaba, H. Z., & Ozdeniz, M. B. (2011). Thermal Comfort of Multiple-skin Facades in Warm-climate Offices. *Scientific Research and Essays*, 6(19), 4065-4078.
- Allen, E., & Iano, J. (2004). *Fundamentals of Building Construction: Materials and Methods* (4th Ed.), New Jersey: John Wiley & Sons Inc.
- Anderson, L. M. (1999). Spalling Brick-Material, Design or Construction Problem?. *Journal of Performance of Constructed Facilities*, 163-171.
- Anon. (2013, May28). 15,000 houses stand empty in TRNC. LGC News. Retrieved from

<http://www.lgcnews.com/index.php?s=15%2C000+houses+stand+empty+in+T>
RNC used on 21/10/2014.

ASHRAE. (2012). *Energy Standard for Buildings Except Low-Rise Residential Buildings*. United States: ASHRAE.

Assaf, S., Al- Hammad, A., & Al-Shihah, M. (1996). Effects of Faulty Design and Construction on Building Maintenance. *Journal of Performance of Constructed Facilities*, 10. 171-174.

Atkinson, G. (1987). A Century of Defects, *Building*, 54-55.

Auchterlounie, T. (2009). Recurring Quality Issue in the UK Private House Building Industry. *Structural Survey*, 27(3), 241-251.

Bailey, D. M., & Bradford, D. (2005). Membrane and Flashing Defects in Low-slope Roofing: Causes and Effects on Performance. *Journal of Performance of Constructed Facilities*, 19, 234-243.

Barry, R. (1980). *The Construction of Buildings: Volum1 (4th Ed.)*, England: Granada Publishing.

Bell, G. R., & Parker, J. C. (1987). Roof Collapse, Magic Mart Store, Bolivar, Tennessee. *Journal of Performance of Constructed Facilities*, 1, 63-77.

Bolduc, W. T. (2011). When the Roof Collapses. *Structure Congress*, 1827-1838.

- Building Research Establishment (BRE). (1991). Housing Defects Reference Manual, the Building Research Establishment Defect Action Sheets. London: E & FN Spon.
- Ching, F. D., & Adams, C. (2001). Building Construction Illustration. New York: John Wiley & Sons Inc.
- Chong, W., & Low, S. (2005). Assessment of Defects at Construction and Occupancy Stages. *Journal of Performance of Constructed Facilities*, 19, 283-289.
- Chong, W., & Low, S. (2006). Latent Building Defects: Causes and Design Strategies to Prevent Them. *Journal of Performance of Constructed Facilities*, 20, 213-221.
- Chudley, R. (1989). Building Construction Handbook. Oxford: Butterworth-Heinemann Ltd.
- CIB Working Commission W86. (1993). Building Pathology: A State-of-the Art Rep. International Council for Building Research Studies and Documentation. Rotterdam, The Netherlands.
- Coffelt, D., & Hendrickson, C. (2012). Case Study of Occupant Costs in Roof Management. *Journal of Architectural Engineering*, 18, 341-348.
- Das, S., & Chew, M. Y. (2011). Generic Method of Grading Building Defects Using FMECA to Improve Maintainability Decisions. *Journal of Performance of Constructed Facilities*, 25, 522-533.

Davies, N., & Jokiniemi, E. (2008). Dictionary of Architecture and Building Construction. Oxford, UK: Architectural Press.

Devlet Planlama Örgütü. (2009). Building Construction and Parcel Statistics. Retrieved from <http://www.devplan.org/Inaat/Eng/Construction%20Statistics%202009.pdf> used on 10/06/2014.

Devlet Planlama Örgütü. (2011). Kktc Nüfus ve Konut Sayımı 2011. Retrieved from http://www.devplan.org/Nufus-2011/nufus%20son_.pdf used on 04/10/2014.

Emmitt, S., & Gorse, C. A. (2005). Barry's Introduction to Construction of Buildings. Oxford: Blackwell Publishing.

Estenssoro, L. F. (1989). Two Roof Failures due to Water Ponding and Related Code Requirements. Journal of Performance of Constructed Facilities, 3, 184-190.

FASIL 96: Yollar ve Binalar Düzenleme Yasası. (2012). Yol ve Binaları Düzenleme Yasası Tüzüğü. Retrieved from http://www.mimarlarodasi.org/assets/docs/yasa-tuzuk/fasil96-tuzugu_temmuz2012.pdf used on 25/7/2014.

Flickinger, D. (2001). Roof Systems. In F. S. Merritt & J. T. Ricketts (Eds.). Building Design and Construction Handbook (6th Ed.), New York: McGraw_Hill.

- Florides, G. A., Tassou, S. A., Kalogirou, S. A., & Wrobel, L. C. (2001). Evolution of Domestic Dwellings in Cyprus and Energy Analysis. *Renewable Energy*, 23, 219-234.
- Forcada, N., Macarulla, M., Gangolells, M., & Casals, M. (2014). Assessment of Construction Defects in Residential Buildings in Spain. *Building Research & Information*, 1-12.
- Foster, J. S. (1994). *Structure & Fabric: Part1* (5th Ed.), London: Longman.
- Foster, J. S., & Greeno, R. (2007). *Structure and Fabric: part 1* (7th ed.). England: Pearson.
- Georgiou, J. (2010). Verification of a Building Defect Classification System for Housing. *Structural Survey*, 28(5), 370-383.
- Georgiou, J., Love, P. E., & Smith, J. (1999). A Comparison of Defects in Houses Constructed by Owners and Registered Builders in the Australian State of Victoria. *Structural Survey*, 17(3), 160-169.
- Google earth. (2014, March 21a). V 7.1.1.1871. Iskele, [map], 35°17'34.99" N, 33°54'38.19" E, Eye alt 10.27 mi. Retrieved from <http://www.earth.google.com>.
- Google earth. (2014, March 21b). V 7.1.1.1871. Kyrenia, [map], 35°19'15.97" N, 33°18'00.38" E, Eye alt 17.24 mi. Retrieved from <http://www.earth.google.com>.

Google earth. (2014, April 20c). V 7.1.1.1871. Famagusta, [map], 35°02',30.24" N, 33°55',49.04" E, Eye alt 17.16 mi. Retrieved from <http://www.earth.google.com>.

Google earth. (2014, July 13d). V 7.1.1.1871. Nicosia, [map], 35°11',42.35" N, 33°15',11.00" E, Eye alt 18.46 mi. Retrieved from <http://www.earth.google.com>.

Gurfinkel, G. (1988). Precast Concrete Roof Structure: Failure and Repair. *Journal of Performance of Constructed Facilities*, 2, 144-158.

Hinks, J., & Cook, G. (1997). *The Technology of Building Defects*. London: E & FN Spon.

Ilozor, B., Okoroh, I., & Egbu, E. (2004). Understanding Residential House Defects in Australia from State of Victoria. *Build Environment*, 39(3), 327-337.

IBC. (2012). *International Building Code*. United States: International Building Code Council.

ICC. (2009). *International Energy Conservation Code*. United States: International Code Council.

ISO. (2005). *Quality Management Principles*. ISO 9000: 2005, Geneva, Switzerland.

IRC. (2012). *International Residential Code*. United States: International Code Council.

Jones, A. P. (1999). Indoor Air Quality and Health. *Atmospheric Environment*, 33(28), 4535-4564.

Jordan, J. W. (2005). Roof Drainage Design and Analysis: Structural Collapse, Responsibility Matrix, and Recommendations, Structures Congress.

Jupp, E. W. (2002). *Roof Watching*. Bristol: Intellect Ltd.

Kiessl, K. (2003). Building Science. In H, Wessely (Ed.), *Roof Construction Manual: Pitched roofs*. Munich: Birkhauser.

Kıbrıs Türk İnşaat Mütcaahhitleri Birliđi. (2012). Tüm Üye Listesi. Retrieved from <http://www.ktimb.org/index.php/tr/uyelerimiz/t%C3%BCm-%C3%BCyeler.html> used on 05/10/2014.

Knocke, J. (1992). *Post Construction Liability and Insurance*. London: E & FN Spon.

Lyons, A. (2004). *Materials for Architects & Builders* (2nd Ed.), Oxford: Elsevier Butterworth-Heinemann.

Macarulla, M., Forcada, N., Casals, M., Gangolells, M., Fuertes, A., & Roca, X. (2013). Standardizing Housing Defects: Classification Validation, and Benefits. *Journal of Construction Engineering and Management*, 139, 968-976.

Max Fordham LLP. (2006). *Environmental Design: an introduction for architects and engineers* (3rd Edition). R. Thomas (Ed.), New York: Taylor & Francis Group.

- McC Campbell, B. H. (1992). Problems in Roofing Design. US: Butterworth-Heinemann.
- Mills, A., Love, P. E., & Williams, P. (2009). Defect Costs in Residential Construction. *Journal of Construction Engineering and Management*, 135, 12-16.
- Morcous, G., & Rivard, H. (2006). Service Life Prediction of Low-Slope Roofing Components in Buildings. *Building Integration Solutions*, 1-10.
- Olubodun, F., & Mole, T. (1999). Evaluation of Defect Influencing Factors in Public Housing in the UK. *Structural Survey*, 17(3), 170-178.
- Özdemir, İ. (n.d.). Yapi Elemanlari (S. Pakpour Trans.). Teknoloji Eğitim Uygulama ve Araştırma Merkezi. Retrieved from http://cekirdekweb.com/Files/WebSite_6/Yapi-Elemanlari-Ders-Notlari.pdf used on 12/01/2015.
- Özdeniz, M. B., & Hançer, P. (2005). Suitable Roof Construction for Warm Climates_ Gazimağusa Case. *Energy and Building*, 37, 643-649.
- Perry, W. C. (2000). Building Cancer. *Forensic Engineering*, 617-625.
- Pinto, J., Varum, H., & Ramos, L. (2011). Two Roofs of Recent Public Buildings, the Same Technological Failure. *Engineering Failure Analysis*, 18, 811-817.

Richardson, B. A. (1991). *Defects and Deterioration in Buildings*. London: E & FN Spon.

Schunck, E., Oster, H. J., Barthel, R., & Kiessl, K. (2003). *Roof Construction Manual: Pitched Roofs* (5th Ed.). H. Wessely (Ed.). (G. Söffker & P. Thrift Trans.), Munich: Birkhauser.

Schunck, E. (2010). *Construction Details*. In C. Hellstern & S. Leitte & J. Billhardt (Eds.), *Flat Roof Construction Manual*. Munich: Birkhauser.

Schunck, E., & Oster, H. J. (2003). *Construction Details*. In H. Wessely (Ed.), *Roof Construction Manual: Pitched Roofs* (5th Ed.). Munich: Birkhauser.

Small, W. W., & Swanson, P. G. (2006). *Roof Collapse_ A Forensic Analysis Years After*. *Forensic Engineering*, 414-422.

Sommerville, J., & McCosh, J. (2006). *Defects in New Homes: An Analysis of Data on 1.696 New UK Houses*. *Structural Survey*, 24(1), 6-21.

Survey System. (2012). *Sample Size Formula*. Retrieved from <http://www.surveysystem.com/sample-size-formula.htm> used on 19/10/2014.

Verhulst, S. M., Deleon, M. A., & East, B. L. (2009). *The Roof Drainage Epidemic*. *Forensic Engineering*, 204-213.R

Walter, A., Brito, J., & Lopes, J. G. (2005). Current Flat Roof Bituminous Membranes Waterproofing Systems_ Inspection, Diagnosis and Pathology Classification. *Construction and Building Materials*, 19, 233-242.

Watt, D. (1999). *Building Pathology: Principles & Practice* (2nd Ed.). Oxford, UK: Blackwell Publishing.

Yorucu, V., & Keles, R. (2007). The Construction Boom and Environmental Protection in Northern Cyprus as a Consequence of the Annan Plan. *Construction Management and Economics*, 25, 77-86.

Picture URLs

[1] <http://www.north-cyprus-villa.com/guide-images/city/citymap-620x383.jpg>

[2] <http://www.kibrisgazetesi.com/wp-content/uploads/2014/01/Bina-2.jpg>

[3] <http://www.propertyinnorthcyprus.com/gallery/371f74fa6a98f1a12f1293754258ef0a.jpg>

APPENDICES

Appendix A: Questionnaire for Constructors (English)

Your information is required for a master thesis in Eastern Mediterranean University related to roof defects in Northern Cyprus. All the collected data will be stored confidentially and only the author will use them for this study. All participants will not be identified and will have the option not to answer. If you do not want to answer any question, please leave it blank.

- **Are you satisfied with the roof systems in North Cyprus?**

Yes No Maybe

- **What are the main problems that you have faced related to the roof construction in North Cyprus? (Choose maximum 5 problems)**

Cost Quality Availability of the materials Strength and stability

Thermal comfort Water resistance Fire resistance Drainage

Speed of construction Durability Appearance Sanitation

Wind resistance Standardization Resistance to mold growth

Resistance to earth quake Air-tightness Resistance to heat flow

Others

- **Rank the following roof structures according to their frequency of implementation from 0 to 100 in a way the sum is 100.**

Flat reinforced concrete structure _____

Inclined reinforced concrete structure _____

Standing roof structure _____

Pitched steel structure _____

Flat steel structure _____

• **Which roof system do you prefer to construct?**

Flat reinforced concrete roof Flat precast concrete roof Flat metal roof

Flat timber roof Pitched reinforced concrete roof Pitched metal roof

Pitched timber roof Standing timber roof Metal folded slab roof

Reinforced concrete folded slab roof Reinforced concrete barrel vaults

Timber barrel vaults Brick barrel vaults Space frames

Tensile (cable network) Membrane roofs Others

• **Which types of roofs have been the most popular roof types in recent years? (During the last 20 years)**

Flat reinforced concrete roof Flat precast concrete roof Flat metal roof

Flat timber roof Pitched reinforced concrete roof Pitched metal roof

Pitched timber roof Standing roof Metal folded slab roof

Reinforced concrete folded slab roof Reinforced concrete barrel vaults

Timber barrel vaults Brick barrel vaults Space frames

Tensile (cable network) Membrane roofs Others

Appendix B: Questionnaire for Constructors (Turkish)

Bilgileriniz Kuzey Kıbrıs'ta çatı kusurlarına bağlı bir yüksek lisans tezi için gereklidir. Tüm toplanan veriler gizli tutulacak ve sadece yazar tarafında bu araştırma için kullanılacak. Katılımcılar tespit edilmeyecek ve cevap seçeneğine sahiptir. Eğer herhangi bir soruya cevap vermek istemiyorsanız, lütfen boş bırakın.

- **Kuzey Kıbrıs'ta çatı sistemlerden memnun musunuz?**

Evet Hayır Belki

- **Kuzey Kıbrıs'ta çatı yapımı ile ilgili esas sorunlar nelerdir? (maksimum 5 faktör seçiniz)**

Fiyat Kalite Malzemelerin mevcut olmaması Dayanıklılık

Termal konfor Suya dayanıklılık Yangına dayanımı Drenaj

İnşa etmenin hızı Görünüş Sanitasyon Rüzgara karşı direnç

Standartlaştırma Küf direnci Depreme dayanımı

Hava sızdırmazlığı Isı akışına karşı direnç Güç ve kararlılık

diğer

- **Toplamı 100 olarak aşağıdaki çatı yapılarına uygulama sıklıklarına göre 0-100 puan verin.**

Düz betonarme çatı _____

Oturma ahşap çatı _____

Eğimli betonarme çatı _____

Düz çelik çatı _____

Eğimli çelik çatı _____

• **Hangi çatı tipi tercih ediyorsunuz?**

- Düz betonarme çatı Düz prekast beton çatı Düz çelik çatı
Düz ahşap çatı Oturtma ahşap çatı Eğimli betonarme çatı
Eğimli çelik çatı Eğimli ahşap çatı Çelik katlanmış döşeme
Betonarme katlanmış döşeme Betonarme beşik kemer
Ahşap beşik kemer Tuğla beşik kemer Uzay çatı sistemi
Tensile (kablo ağı) Membrane çatı Diğer

• **Son yıllarda hangi Çatı tipi daha popülerdir? (Son 20 yılda)**

- Düz betonarme çatı Düz prekast beton çatı Düz çelik çatı
Düz ahşap çatı Oturtma ahşap çatı Eğimli betonarme çatı
Eğimli çelik çatı Eğimli ahşap çatı Çelik katlanmış döşeme
Betonarme katlanmış döşeme Betonarme beşik kemer
Ahşap beşik kemer Tuğla beşik kemer Uzay çatı sistemi
Tensile (kablo ağı) Membrane çatı Diğer

Appendix C: Questionnaire for the Owners (English)

Your information is required for a master thesis in Eastern Mediterranean University related to roof defects in Northern Cyprus. All the collected data will be stored confidentially and only the author will use them for this study. All participants will not be identified and will have the option not to answer. If you do not want to answer any question, please leave it blank.

- **Are you satisfied with the roof systems in North Cyprus?**

Yes No Maybe

- **What are the main problems that you have faced related to the roof construction in North Cyprus? (Choose maximum 5 problems)**

Cost Quality Availability of the materials Strength and stability

Thermal comfort Water resistance Fire resistance Drainage

Speed of construction Durability Appearance Sanitation

Wind resistance Standardization Resistance to mold growth

Resistance to earth quake Air-tightness Resistance to heat flow

Others

- **Which material do you prefer for the structure of roofs?**

Timber Reinforced concrete Precast concrete Metal Brick

- Which roof form do you prefer? (Choose maximum 3)

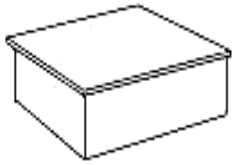

Flat roof

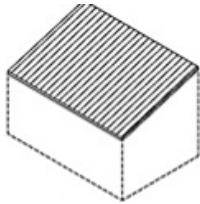

Pent roof

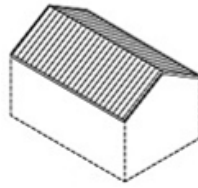

Duo-pitched roof

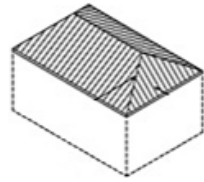

Hipped roof

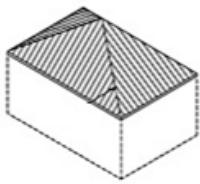

Pavilion roof

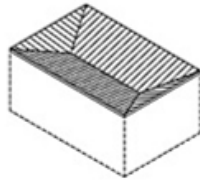

Butterfly roof

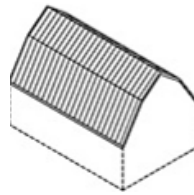

Gabled mansard roof

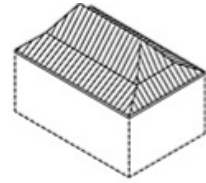

Hipped knee roof

Appendix D: Questionnaire for the Owners (Turkish)

Bilgileriniz Kuzey Kıbrıs'ta çatı kusurlarına bağlı bir yüksek lisans tezi için gereklidir. Tüm toplanan veriler gizli tutulacak ve sadece yazar tarafında bu araştırma için kullanılacak. Katılımcılar tespit edilmeyecek ve cevap seçeneğine sahiptir. Eğer herhangi bir soruya cevap vermek istemiyorsanız, lütfen boş bırakın.

- **Kuzey Kıbrıs'ta çatı sistemlerden memnun musunuz?**

Evet Hayır Belki

- **Kuzey Kıbrıs'ta çatı yapımı ile ilgili esas sorunlar nelerdir? (maksimum 5 faktör seçin)**

Fiyat Kalite Malzemelerin mevcut olmaması Dayanıklılık

Termal konfor Suya dayanıklılık Yangına dayanımı Drenaj

İnşa etmenin hızı Görünüş Sanitasyon Rüzgara karşı direnç

Standartlaştırma Küf direnci Depreme dayanımı

Hava sızdırmazlığı Isı akışına karşı direnç Güç ve kararlılık

diğer

- **Çatı yapımı için hangi materialı tercih ediyorsunuz?**

Ahşap Betonarme Prekast Beton Çelik Tuğla

- Hangi çatı formu tercih ediyorsunuz? (maksimum 3 form seçiniz)

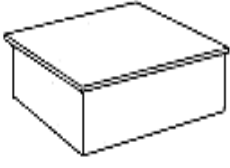

Düz çatı

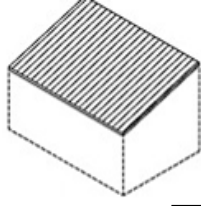

Tek eğimli çatı

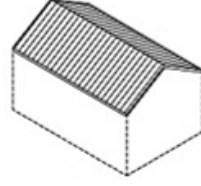

Çift eğimli çatı

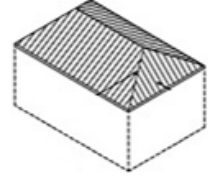

Kırma çatı

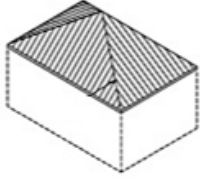

Çadır çatı

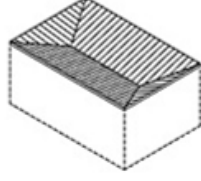

Kelebek çatı

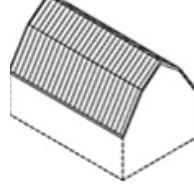

Beşik kırık çatı

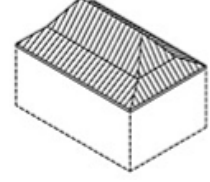

Kırma çifte sağrılı çatı