

**Assessment of Reusability Potential of Reinforced  
Concrete as Waste Material via BIM: A Case Study  
of Office Building EMU Faculty of Architecture**

**Ceren Demirtaş**

Submitted to the  
Institute of Graduate Studies and Research  
in partial fulfillment of the requirements for the degree of

Master of Science  
in  
Architecture

Eastern Mediterranean University  
August 2023  
Gazimağusa, North Cyprus

Approval of the Institute of Graduate Studies and Research

---

Prof. Dr. Ali Hakan Ulusoy  
Director

I certify that this thesis satisfies all the requirements as a thesis for the degree of Master of Science in Architecture.

---

Prof. Dr. Rafooneh Mokhtar Shahi Sani  
Chair, Department of Architecture

We certify that we have read this thesis and that in our opinion it is fully adequate in scope and quality as a thesis for the degree of Master of Science in Architecture.

---

Prof. Dr. Sadiye Müjdem Vural  
Supervisor

---

Examining Committee

1. Prof. Dr. Sadiye Müjdem Vural

---

2. Assoc. Prof. Dr. Polat Hancer

---

3. Asst. Prof. Dr. Ehsan Reza

---

## ABSTRACT

Construction sector can be counted as the main problem of consuming resources and waste generation throughout the world (Zhang, C., et al., 2021). It has a negative impact on land deterioration, solid waste production, energy consumption, emission of gas, natural resource consumption (Lu, W., Yuan, H., 2011). As stated by the report by Environmental Protection Agency in 2017, 569 million tons of Construction and Demolition (C&D) waste was generated in the United States, however only 40% of C&D waste that comes from buildings is reused or recycled, while 35% of worldwide C&D waste sent to be landfilled. It is vital to understand that C&D waste has a great potential of reuse and recycling (Guerra, B. C., et al., 2020). C&D waste generation can be originated with man-made sources and nature-made sources. It can be accepted as public works construction and maintenance, building construction works, and building renovation and demolition works. Nature-made sources of C&D waste on the other hand, can be accepted as natural disasters such as earthquakes, floods, hurricanes, and tsunamis (Menegaki, M. & Damigos, D., 2018).

Research on C&D waste management has been conducted globally in an attempt to mitigate the harm that the construction sector causes. Building Information Modelling (BIM) has been increasingly effective and accepted construction methodology in recent years (Nikmehr, B., et al., 2021). BIM can be defined as a digital depiction of a facility's functional and physical attributes (Kylili, A. & Fokaidis, P. A., et al., 2015). According to the National Institute of Buildings Sciences (2014), a BIM model is shared knowledge resource that contains information about a structure that can be trusted as a reliable base for choices made through its lifecycle. BIM enables the

integration of energy-efficient design into the evaluation of energy use over the building life cycle. Incorporating BIM technologies with Life Cycle Assessment methodology is one of the proposed strategies according to many academics, to analyze environmental consequences in the building sector (Najjar, M., et al., 2017).

This thesis provides a literature review through the current situation of concrete as C&D waste material. It aims to understand the reusability and recyclability potential of reinforced concrete material that being used as structural elements by using visualizing it BIM program Autodesk Revit in corporation with One Click LCA program to achieve building circularity assessment. It concludes the study with interpretations for reusability and recyclability state of reinforced concrete material out of the results that obtained from One Click LCA building circularity report. The main aim is to compare the reuse, recycle, landfill options for reinforced concrete material of the selected case and give a sustainable solution for the projects to be demolished and reconstructed.

**Keywords:** Building Circularity, Reinforced Concrete, Waste Concrete, Material Reuse, Building Information Modelling (BIM).

## ÖZ

İnşaat sektörü, dünya genelinde kaynakların tüketilmesi ve atık oluşumunun temel sorunu olarak gösterilmektedir (Zhang, C., vd., 2021). İnşaat sektörü arazi bozulması, katı atık üretimi, enerji tüketimi, gaz emisyonu ve doğal kaynakların tüketimi üzerinde olumsuz bir etkiye sahiptir (Lu, W., Yuan, H., 2011). Çevre Koruma Ajansı'nın 2017 raporuna göre, ABD'de 569 milyon ton İnşaat ve Yıkım (C&D) atığı oluşmuştur, ancak binalardan kaynaklanan C&D atıklarının yalnızca %40'ı yeniden kullanılmakta veya geri dönüştürülmekte, dünya genelinde ise C&D atıklarının %35'i düzenli gömülmektedir. C&D atıklarının büyük bir yeniden kullanım ve geri dönüşüm potansiyeline sahip olduğunu anlamak hayati önem taşımaktadır (Guerra, B. C., vd., 2020). C&D atık üretimi, insan yapımı atıklar ve doğa yapımı atıklardan kaynaklanabilmektedir. İnsan yapımı kaynaklar, kamu işleri inşaat ve bakımı, bina inşaat işleri ve bina yenileme ve yıkım işleri olarak kabul edilebilir. C&D atıklarının doğa kaynaklı kaynakları ise deprem, sel, kasırga ve tsunami gibi doğal afetler olarak kabul edilebilir (Menegaki, M. & Damigos, D., 2018).

İnşaat ve yıkım atıklarının yönetimi (C&DWM), inşaat sektörünün neden olduğu zararı azaltmak amacıyla dünya çapında araştırmalara konu olmuştur. Yapı Bilgi Modellemesi (BIM) son yıllarda giderek daha etkili ve kabul gören bir inşaat metodolojisi haline gelmiştir (Nikmehr, B., vd., 2021). BIM, bir binanın işlevsel ve fiziksel özelliklerinin dijital bir tasviri olarak tanımlanabilir (Kylili, A. & Fokaidis, P. A., vd., 2015). Ulusal Yapı Bilimleri Enstitüsü'ne (2014) göre, bir BIM modeli, bir yapı hakkında yaşam döngüsü boyunca yapılan seçimler için güvenilir bir temel olarak güvenilebilecek bilgiler içeren paylaşılan bir bilgi kaynağıdır. BIM, enerji tasarruflu

tasarımın bina yaşam döngüsü boyunca enerji kullanımının değerlendirilmesine entegre edilmesini sağlar. BIM teknolojilerinin Yaşam Döngüsü Değerlendirme metodolojisi ile birleştirilmesi, birçok akademisyene göre bina sektöründeki çevresel sonuçları analiz etmek için önerilen stratejilerden biridir (Najjar, M., vd., 2017).

Bu tez, C&D atık malzemesi olarak betonun mevcut durumu üzerinden bir literatür taraması sunmaktadır. Yapısal eleman olarak kullanılan betonarme malzemenin yeniden kullanılabilirlik ve geri dönüştürülebilirlik potansiyelini, bina döngüsellik değerlendirmesi elde etmek için One Click LCA programı ile birlikte Autodesk Revit BIM programını kullanarak görselleştirerek anlamayı amaçlamaktadır. Çalışma, One Click LCA bina döngüsellik raporundan elde edilen sonuçlardan betonarme malzemenin yeniden kullanılabilirlik ve geri dönüştürülebilirlik durumuna ilişkin yorumlarla sonuçlanmaktadır. Temel amaç, seçilen yapı örneğinin betonarme malzemesi için yeniden kullanım, geri dönüşüm, düzenli depolama seçeneklerini karşılaştırmak ve yıkılıp yeniden inşa edilecek projeler için sürdürülebilir bir çözüm sunmaktır.

**Anahtar Kelimeler:** Bina Döngüsellığı, Betonarme, Atık Beton, Malzemenin Yeniden Kullanımı, Bina Bilgi Modellemesi (BIM).

# DEDICATION

I would like to dedicate this thesis to my beloved family,

**Berrin Serter, Emel Serter,**

**Coskun Serter, Damla Serter, Aras Gur Serter,**

**Ibrahim Serter, Cigdem Polatoglu Serter,**

and

my life partner **Orhun Tokgoz,**

to those I will be forever grateful

for the endless support

and

unconditional love.

## ACKNOWLEDGMENT

I would like to express my gratitude to my supervisor, dear Prof. Dr. Müjdem Vural, for her patience and faith in me. I was able to complete this task with the support of her intense attention, academic recommendations, and obscenely long patience.

I would like to thank my thesis jury members, dear Assoc. Prof. Dr. Polat Hancer, and dear Asst. Prof. Dr. Ehsan Reza for the valuable contribution to my thesis.

I also would like to give my deepest respect to the beloved and valuable instructors of the Faculty of Architecture of EMU, dear Prof. Dr. Ozgur Dincyurek, Prof. Dr. Kokan Grchev, Dr. Olgica Grcheva for sharing their endless support and knowledge along this journey.

Finally, I would like to offer my gratitude to my dear friends Zeynep & Tuna Vidinliogullari, Hasret Destebanoglu, Ozge Selen Koc, Hasan Debes, Ayşe Ece Gulten, Mert Korler, Shahd Adnan Qzeih, Yusuf Gazi Kucuk, Ecenur Artun and Aybike Solak for the support they gave me and being there for me all the time.

# TABLE OF CONTENTS

ABSTRACT .....	iii
ÖZ .....	v
DEDICATION .....	vii
ACKNOWLEDGMENT .....	viii
LIST OF TABLES .....	xii
LIST OF FIGURES.....	xiii
LIST OF SYMBOLS AND ABBREVIATIONS.....	xv
1 INTRODUCTION.....	1
1.1 Background of the Research .....	1
1.2 Problem Statement .....	4
1.3 Aims and Objectives of the Research .....	5
1.4 Research Method.....	6
1.5 Limitations .....	9
2 LITERATURE REVIEW.....	11
2.1 Construction and Demolition (C&D) Waste Management.....	11
2.1.1 Definition of Waste C&D Waste .....	12
2.1.2 Introduction to Concrete .....	13
2.1.3 Concrete as Waste Material .....	15
2.1.4 The Concept of Sustainable Concrete .....	16
2.1.5 Waste Management Strategies .....	20
2.2 Circular Economy Concept.....	22
2.3 Building Circularity .....	25
2.3.1 Building Circularity Principles .....	25

2.3.1.1	Material and Component Production .....	26
2.3.1.2	Design Stage.....	27
2.3.1.3	End-of-Life (EoL) .....	28
2.4	Introduction to Environmental Impact Assessment (EIA).....	28
2.4.1	Brief Information about EIA .....	28
2.4.2	Life Cycle Assessment (LCA) .....	31
2.4.3	Life Cycle Assessment Tools in Use .....	35
2.4.3.1	One Click LCA Program.....	36
2.5	Building Information Modelling (BIM) and LCA integration.....	37
2.5.1	Definition of BIM .....	40
2.5.1.1	Autodesk Revit as Selected BIM Software.....	41
2.5.1.2	Autodesk Revit and One Click LCA Integration .....	41
3	CASE STUDY AND THE METHOD.....	43
3.1	EMU, Faculty of Architecture, Office Building as a Case Study .....	43
3.1.1	Locational Analysis.....	43
3.1.2	Brief Information about EMU, Faculty of Architecture .....	45
3.1.3	Detailed Information about Office Building .....	48
3.2	Method of the Study .....	49
3.2.1	Visualization of Selected Building in BIM Environment .....	51
3.2.2	Integration of Autodesk Revit and One Click LCA.....	53
3.2.3	Characterization of Office Building for Building Circularity Tool ...	60
4	RESULTS AND DISCUSSION .....	66
4.1	Building Circularity Results of The Office Building.....	66
4.1.1	Building Circularity Data Optimization for EPD Definition .....	66

4.1.2	Building Circularity Data Optimization for Crushing Concrete into Aggregate.....	70
4.1.3	Building Circularity Data Optimization for Reuse as Material .....	73
4.1.4	Building Circularity Data Optimization for Landfilling for Concrete	77
5	CONCLUSION .....	82
	REFERENCES.....	88

## LIST OF TABLES

Table 1: Material selection and mapping in the study.....	60
Table 2: Data Optimization for Using EoL Defined in EPD .....	68
Table 3: Building Circularity Report of Returned Material for Using EoL Defined in EPD.....	69
Table 4: Building Circularity Report of Recovered Material for Using EoL Defined in EPD.....	70
Table 5: Data Optimization for Using Crushing Concrete into Aggregate.....	71
Table 6: Building Circularity Report of Returned Material for Concrete Crushed into Aggregate.....	73
Table 7: Building Circularity Report of Recovered Material for Concrete Crushed into Aggregate.....	73
Table 8: Data Optimization for Using Reuse as Material Option.....	74
Table 9: Building Circularity Report of Returned Material for Reuse as Material Option.....	76
Table 10: Building Circularity Report of Recovered Material for Reuse as Material Option.....	77
Table 11: Data Optimization for Using Crushing Concrete to Aggregate or/and Landfill Option.....	78
Table 12: Building Circularity Report of Returned Material for Landfilling for Concrete Option.....	79
Table 13: Building Circularity Report of Recovered Material for Landfilling for Concrete Option.....	80

## LIST OF FIGURES

Figure 1: Process of Research.....	8
Figure 2: C&D Debris Generation Composition by Material.....	12
Figure 3: Components of Concrete.....	14
Figure 4: Life cycle of Concrete .....	17
Figure 5: Basic composition of demolition wastes .....	19
Figure 6: Interaction of the categories of waste causing variables .....	21
Figure 7: Evolution of Waste Hierarchy in Time .....	22
Figure 8: The butterfly diagram of CE.....	24
Figure 9: Circular building principles through life cycle .....	26
Figure10: Environmental Impact Assessment .....	30
Figure 11: Entire Information Analysis Process Flow Chart .....	31
Figure 12: Stages of Life Cycle Assessment.....	33
Figure 13: Workflow of LCA tools with BIM.....	37
Figure 14: Building Information Modelling (BIM) applications across buildings’ lifecycles.....	39
Figure 15: Integration of BIM and LCA.....	40
Figure 16: BIM integrated LCA workflows.....	42
Figure 17: Location of Cyprus.....	45
Figure 18: Division of the cities of TRNC.....	46
Figure 19: Borders of Eastern Mediterranean University.....	47
Figure 20: Borders of Faculty of Architecture, EMU.....	48
Figure 21: EMU (left) – Office Building (right) location.....	49

Figure 22: EMU, Faculty of Architecture ‘Office Building’ Visualization by Autodesk Revit.....	53
Figure 23: Logging in process for One Click LCA add-in in Autodesk Revit .....	55
Figure 24: Arrangement of settings for One Click LCA add-in in Autodesk Revit.....	56
Figure 25: Selecting the scope of assessment as selecting model for One Click LCA add-in in Autodesk Revit.....	57
Figure 26: Selecting the detailed scope for One Click LCA add-in in Autodesk Revit.....	58
Figure 27: Defining benchmark parameters for One Click LCA add-in in Autodesk Revit.....	61
Figure 28: Arranging the settings for One Click LCA Cloud, One Click LCA webpage.....	62
Figure 29: Creating a New Design for One Click LCA Cloud, One Click LCA webpage.....	63
Figure 30: Creating a New Design for One Click LCA Cloud, One Click LCA webpage.....	64
Figure 31: Area and user definition for One Click LCA Cloud, One Click LCA webpage .....	65
Figure 32: Building Circularity Results for EOL defined in EPD Option.....	68
Figure 33: Building Circularity Results for Reinforced Concrete Crushed into Aggregate Option .....	72
Figure 34: Building Circularity Results for Reuse as Material Option.....	75
Figure 35: Building Circularity Results for Refilling for Concrete Option.....	79

## LIST OF SYMBOLS AND ABBREVIATIONS

BIM	Building Information Modelling
BREEAM	The Building Research Establishment's Environmental Assessment
CEAP	Circular Economy Action Plan
C&D	Construction and Demolition
C&DW	Construction and Demolition Waste
CWM	Construction Waste Management
CO <sub>2</sub>	Carbon Dioxide
DW	Demolition Waste
EIA	Environmental Impact Assessment
EoL.	End of Life
EMU	Eastern Mediterranean University
EPA	Environmental Protection Agency
RCA	Recycled Coarse Aggregates
LCA	Life Cycle Assessment
LCI	Life Cycle Inventory
LCIA	Life Cycle Impact Assessment Method
LEED	Leadership in Energy and Environmental Design
NEPA	The National Environmental Policy Act
SMM	Sustainable Material Management
TRNC	Turkish Republic of Cyprus

# Chapter 1

## INTRODUCTION

### 1.1 Background of the Research

Building organizations involved in construction as well as governments are now impacted by C&DW, which is a global concern (Solis-Guzman et al., 2009). The rising levels of waste generation become a critical issue due to the lack of control mechanisms, and the rapid growth of cities and towns. The EU's largest waste stream by weight is C&DW, of which the majority is made up of minerals. According to Eurostat (2019a), 374 million tonnes of garbage from building and demolition were produced in 2016. Buildings and construction are closely linked to the economy, local employment, and quality of life. The building sector must support the actions taken by the movers and shakers for being energy efficient and effectively usage of natural resources. Currently, about 75% of the stock of buildings is energy inefficient, and more than 85% of today's structures are expected to be in use in 2050. Building energy and rehabilitation is proceeding, although at an extremely slow rate (EEA briefing, 2022). In 2008, C&DW has been present in EU legislation up to a 70 percent recovery target. Additionally, in 2015, Circular Economy Action Plan (CEAP) has launched to create a new path for waste management. The purpose of these publications is to investigate and synthesize the connections between the concepts of the shift towards a circular economy and the better management of C&DW objectives (Eionet Report, ETC/WMGE 2020/1).

There are significant efforts being made by numerous countries all around the world to prevent the unwanted results of construction and demolition activities. The number of C&D debris produced in the US is tracked by the Environmental Protection Agency (EPA). Products such as steel, wood, drywall, brick and clay tile, asphalt shingles, concrete, and asphalt concrete are regarded as contributing to the formation of waste during construction and destruction. The EPA predicted in 2018 that there were 600 million tons of C&D waste in the United States.

Sustainable material management (SMM) approach One of the most prevalent waste forms in modern society today is C&DW. SMM approach can be explained as a systematic approach for using and reusing materials effectively over their lifecycles. Sustainable material management aims using less material, reducing the toxicity of materials, and reducing environmental impacts throughout the material life cycle. The worldwide raw material use increased during the 20th century at a pace that was roughly twice as fast as population development, according to the Annex to the June 8, 2015, Declaration of the G7 Leaders. The use of basic materials has increased by 0.4 percent for every percent growth in gross domestic product. The environment has paid a price for this rising demand, including habitat loss, species loss, overstressed fishing, and desertification. Throughout the lifecycle of materials, their impacts on the environment are massive. Raw material acquisition, materials manufacturing, use/reuse/maintenance, and waste management are the main stages in a lifecycle of a material. According to EPA's waste characterization report, Advancing Sustainable Materials Management: 2018 Fact Sheet, 600 million tons of C&D debris were generated in the United States in 2018. Demolition activities indicates more than 90 percent of total C&D debris generation, while construction represents less than 10

percent. Over 455 million tons of C&D debris were sent to next use and under 145 million tons were sent to landfills.

Considering individuals spend 90% of our time in buildings or infrastructure such as roads, highways, bridges etc., construction materials play an immense part in every aspect of our lives. Millions of people are employed in the building industry and its associated projects. Hereby, construction industry uses 50% of raw materials, consumes 40% of energy and eventually generates 50% of total waste (Oikonomou, N. D., 2004).

The most commonly used material concrete is a composite material made up of several components including water, aggregates, additives, and binding elements. The role of aggregate as an ingredient is vital due to its occupancy as volume which is around 60-75% (Behera, M., et al, 2014). The role of aggregates in a mixture of concrete is vital in terms of reusing and recycling purposes. Therefore, many researchers have been focusing on recycled aggregates and mechanisms of using it effectively. Concrete is firm and durable material due to its characteristics and binding material specifications. Because of worldwide usage of concrete, it is creating a global problem to be solved in terms of sustainability. In summary, construction and demolition waste (CDW) is a combination of various materials produced by building, remodeling, and demolition operations. These materials include hazardous, non-hazardous, and neutral waste. Additionally, materials that might be produced unexpectedly by natural catastrophes like earthquakes, floods, hurricanes, and tsunamis are included in C&DW (Menegaki, M. & Damigos, D., 2018). A potential approach to prevent the demolition of concrete structures is to design buildings with future disassembly in mind, allowing for reuse and adaptation (Salama, W., 2017).

Growing interest in the many options for managing resources and trash is needed to develop strategies for integrated, sustainable resource and waste management policies. Through the use of life cycle assessment (LCA), various waste management techniques' environmental features may be detailed, and their potential environmental consequences can be compared. (Cherubini, F., et al., 2009). A product will have many structural life cycles if reuse or recycling strategies are used. As a result, the distribution of environmental consequences becomes a research focus, which also plays a significant role in the variances in study results. (Xia, B. & Xiao, J., 2019).

## **1.2 Problem Statement**

Concrete, as a structural material, has been the most preferable material and the most prevalent structural material to produce buildings throughout the world, specifically in Cyprus (Celikdag, M. & Naimi, S., 2011). Concrete is accepted as an economic and commonly used material; therefore, it is mostly preferred by the contractors and employers. The amount of concrete in use is leading the sector towards to rethinking about the end of life (EoL) scenarios. When a structure reaches the end of its useful life, its recyclable elements can either be recycled or dumped in a landfill (Akanbi, L., 2019). The concrete material creates the main wastage in term of volume to be landfilled if not behaved in a sustainable manner. Specifically, newly developed countries are in lack of achieving a management system on waste materials and buildings that generates waste components. TRNC, and Famagusta for this study, where Eastern Mediterranean University (EMU) established, is one of the countries that is lack of system for waste management, therefore this study suggests sustainable actions to be taken for managerial issues on waste building materials and components usage. According to many researches has been done recently, it is clear to see that there is a gap for achieving reusability and recyclability potential of reinforced concrete

elements of buildings that came to its end-of-life in TRNC, Famagusta. Therefore, the scope of this study is to find out the possibility of reusing, recycling the structural reinforced concrete, or crushed in aggregates, or landfill selections in constructing new buildings, and reconstruct the building with recycled concrete materials that obtained from the building to be demolished in the buildings for newly developing city of TRNC, Famagusta.

### **1.3 Aims and Objectives of the Research**

Sustainable construction has become a vital step globally, and it is even a bigger concern in the developing countries such as North Cyprus. Construction sector became the major factor of North Cyprus for rapidly growing. Therefore, the demand for new development in construction sector is in increase and the usage of concrete is relatively increasing with the demand (Elmualim, A., Alp, D., 2016).

This thesis investigates the potentials of reusability, and recyclability factors of the buildings' components which are composed of reinforced concrete that completed its lifecycle with the help of BIM technology and LCA building circularity tool. The building circularity tool is working within the One Click LCA program and works in material bases for this study. The research will provide a method for re-evaluating the possible reuse, recycle and landfill options for a building that reached to its end of life. The study is also enhancing the usage of BIM technology to achieve a better understanding on the selected building as case study and calculate the components of reinforced concrete to be calculated in the most accurate way. The combination of BIM and LCA program is going to be given the needed calculation on material recovery scenarios.

To summarize, there are main goals for this study:

- To obtain a well-researched literature review on waste materials, concrete as waste material, building information modelling and life cycle assessment
- To have correct drawings of the case study building on BIM Program which is Autodesk Revit and obtain the correct calculations in terms of building components
- To practice and obtain a building circularity report on One Click LCA program to achieve recoverable materials selection for possible future usages.

The thesis is being conducted by investigating a building by selecting a case study which is the Office Building in The Faculty of Architecture in Eastern Mediterranean University (EMU). The office building is being examined with the help of BIM program which is Autodesk Revit to be able to easily calculate the volumes of the concrete in the project for assessing the reusability potential. The next step is to integrate the detailed building information that is done with Autodesk Revit to one of the most commonly used LCA programs, One Click LCA, to obtain the recycle and reuse possibility results.

#### **1.4 Research Method**

This study performs quantitative research by evaluating reinforced concrete recyclability, reusability with building circularity tool inside the life cycle assessment program called One Click LCA. The thesis has a descriptive method to be able to collect the needed information to conduct this study. The literature has been overviewed thoroughly in related with the topic to be able to find the gaps and give a

extensive understanding. Another method is examination method where the study makes observation on a specific case. The case study must be investigated extensively for achieving qualitative and quantitative values. The other method this thesis has is the simulation method where the case study needs to be redrawn in a BIM environment to be able to get quantitative data to be evaluated.

One Click LCA and the building circularity tool works based on a database that is created by the developer firms which has different parameters than LCA assessment tools. It directly examines the returned and recovered materials that already came to its end of life as a material or building component. Circularity of buildings mainly gives results on tracking, quantifying, and optimizing the materials being in used or reached to its end of life.

When the results to be obtained as a result of the analysis of waste concrete with the One Click LCA program; it is seen that it has a positive effect on many factors such as environmental, ecological, sustainable.

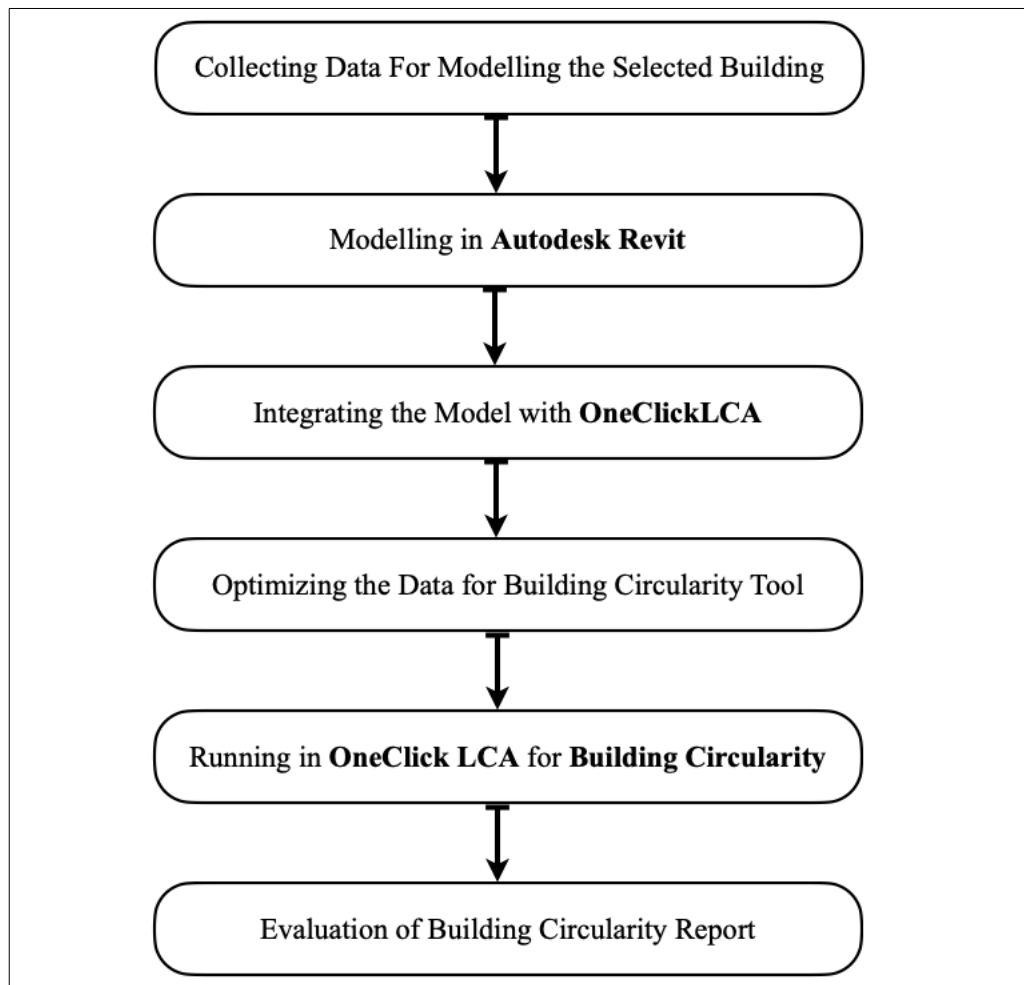

Figure 1: Process of the Research (Drawn by Author, 2023)

The thesis has 5 main chapters which starts with the introduction and sums up with conclusion.

Chapter 1 mainly describes the main aims and objectives of the thesis. It also explains the research questions to be answered within the problems stated in the country and globally. It highlights the method to be used in the thesis for achieving the results and explains the limitations that are valid for the thesis to be conducted. The chapter 2 is explaining the literature review that is needed to be clarified for method to be applied. It defines the material to be investigated in this thesis which is concrete and the sustainability of concrete. It is vital to understand the current situation and working

scheme of the concrete material to be working with. Later on, it explains the C&D waste management within the scope of material concrete. It also opens up the subtopics which is the environmental impact assessment (EIA) and life cycle assessment (LCA). Later it gives information about the selected LCA tool, One Click LCA program, the working process and highlights the advantages and disadvantages of the program. The chapter 3 is mainly explaining the selected case which is the Office Building of Faculty of Architecture in EMU. It gives a brief information about the country, site specifications and gives main information about the building itself to be assessed. Later, it explains in detail the method to be used with subtopics by adding visuals from the programs to clarify the results. In chapter 4, it gives the results that obtained from One Click LCA program and building circularity to be evaluated. Chapter 5 concludes the thesis with results and the predictions of the material reusability and recyclability if any that are came out of building circularity tool. It also highlights the importance of sustainable thinking in the construction industry. It gives suggestions for the next studies to be conducted in the field of material sustainability and reusability for the benefit of the sector and eventually for the future of the world.

## **1.5 Limitations**

There were many factors that limited this study. The main focus for this study is to assess the possible reusable and recyclable materials via building circularity tool to suggest a sustainable path for rapidly growing construction sector in Famagusta city. The analyses were obtained as far as supported by the student versions of Revit and Building Circularity tool within One Click LCA software. This study concludes the building components which are reinforced concrete and did not conclude the other materials or building components for recycling and reuse purposes. The function of

the building as a selected case is office building, with not concluding other buildings such as residential, health care and so on.

Another limitation for this study is the evaluation method. The method is limited by the building circularity tool and the parameters that are set within the tool working environment. The building circularity tool is an embedded tool that is working inside and along with the life cycle assessment tool of One Click LCA program. This method of building circularity tool is evaluating the materials and components individually in terms of material recovery and material returning to the cycle possibility with quantitative feedback as percentage. To be able to narrow the scope of the thesis, the study will be focusing on the structural parts which are composed of reinforced concrete parts of the building by evaluating the different end of life scenarios such as crushing concrete into aggregate, landfilling for concrete, end-of-life (EOL) definition in Environmental Protection Department (EPD), reuse as material.

It also limits the materials to be recovered out of the demolition periods by selecting the concrete material. The reason for selecting concrete material is there are many applications on concrete recyclability and reusing possibility to be adapting this new developing county, North Cyprus. Another reason for choosing concrete is that it is the most used material in the island of Cyprus, therefore there is a massive amount of source for using it in the process of reusability and recyclability of the material. Since a commercial infrastructure hardware could not be provided, no cost calculation could be made in the life cycle analysis. This thesis will set a precedent for future research and academic studies will be able to carry out detailed studies on commercial versions of the One Click LCA program and building circularity tool.

## **Chapter 2**

### **LITERATURE REVIEW**

#### **2.1 Construction and Demolition (C&D) Waste Management**

Waste is any action that consumes resources but provides no value, according to Womack and Jones (1996). Data obtained from the EPA indicates that solid waste includes garbage or refuse, sludge from wastewater treatment plants, water supply treatment plants, or air pollution control facilities, as well as other discarded materials as a result of industrial, commercial, mining, agricultural, and community activities. It is undoubtedly the case that each action we take, generates a certain amount of waste. Additionally, solid waste may be defined as a material that is abandoned, is thought to be naturally waste-like, or is recycled in a certain way.

The construction industry has been considered to be a significant cause of environmental deterioration

(Lu and Yuan, 2011). Building sector is also largely to blame for the enormous volumes of construction and demolition (C&D) debris that is disposed by the practice named landfills annually and, using excessive amounts of natural resources (EPA, 2019a).

The field of construction waste management is concerned with controlling the generation, recovery, processing, and disposal of construction wastes in a manner that

respects best practices for human health, other environmental principles, and engineering standards (Rajendran, P., 2012). Debris that comes from C&D activities is generated from a number of different sources, such as demolition, renovation, and construction. Materials that originate from C&D debris generation by is displayed in Figure 2. The materials that are shown in the figure 2 is produced by the C&D activities which consist of steel, drywall and plaster, concrete, asphalt concrete, asphalt shingles, brick and clay tile, and wood goods (EPA, 2018).

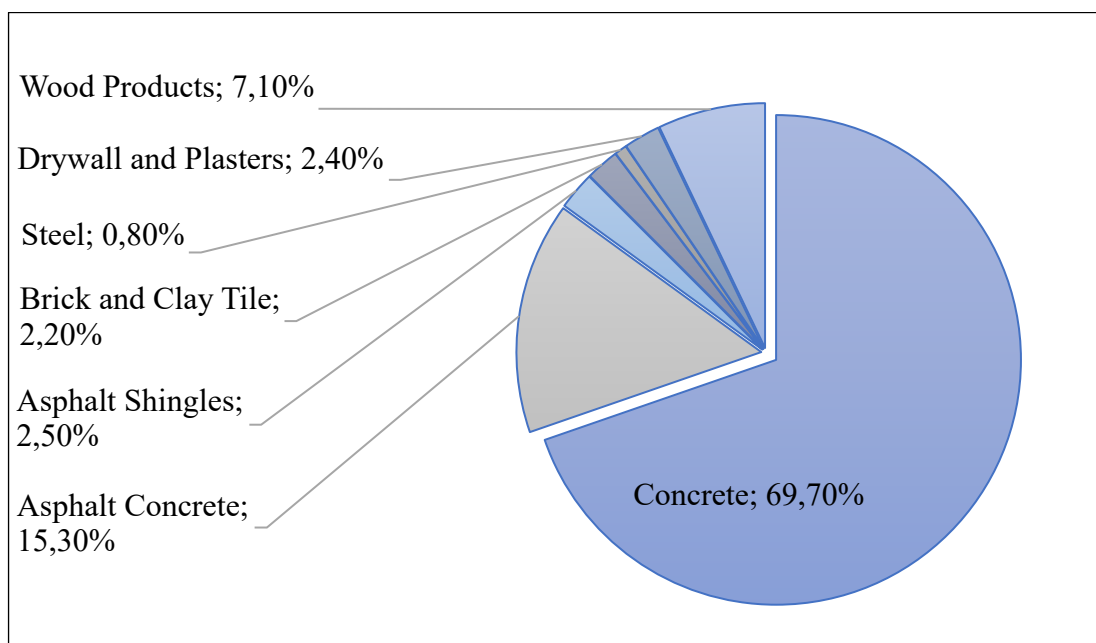

Figure 2: C&D Debris Generation Composition by Material (Depicted from; EPA, 2018)

Construction and demolition debris estimations according to EPA calculations are demonstrated. Figure 2 shows that with 69.7% of total, concrete material was the most prevalent, followed by asphalt concrete with 15.3%. Items made of wood made up 7% of total, while all other items made up the remaining 8%.

### 2.1.1 Definition of Waste C&D Waste

C&D waste must be considered to be reused and also recycled in addition to being minimized to decrease the pressure on landfills. Construction activities that can accept recyclable or materials which is reusable should be explored in order to optimize the sustainability rates of C&D waste. Consequently, during the phase of design, it is crucial to consider functionality, alternatives for design that can accept recyclable or reused components. From the standpoint of C&D waste management and reduction, numerous trustworthy choices for building procedures and design alternatives are compared. The procedures to study construction activities, as well as design alternatives, and systems in design stages, planning phases, and pre-construction phases, may be supported by building information technology (BIM) (Won, J., & Cheng, J.C., 2017).

### **2.1.2 Introduction to Concrete**

The world's preference as a structural material is concrete due to the increased numbers. It is essential to many major infrastructure projects. In terms of ecology, economy, and natural resources, it is nearly hard to conceive replacing concrete with alternative material (Flatt, R. J., et al., 2012). According to the explanation that is done by America's Cement Manufacturers (cement.org), concrete is a mixture of paste which is Portland cement, and water. The binds with sand and gravel or crushed stones are called as aggregates which constitutes 60-75% of the total mixture (Figure 3).

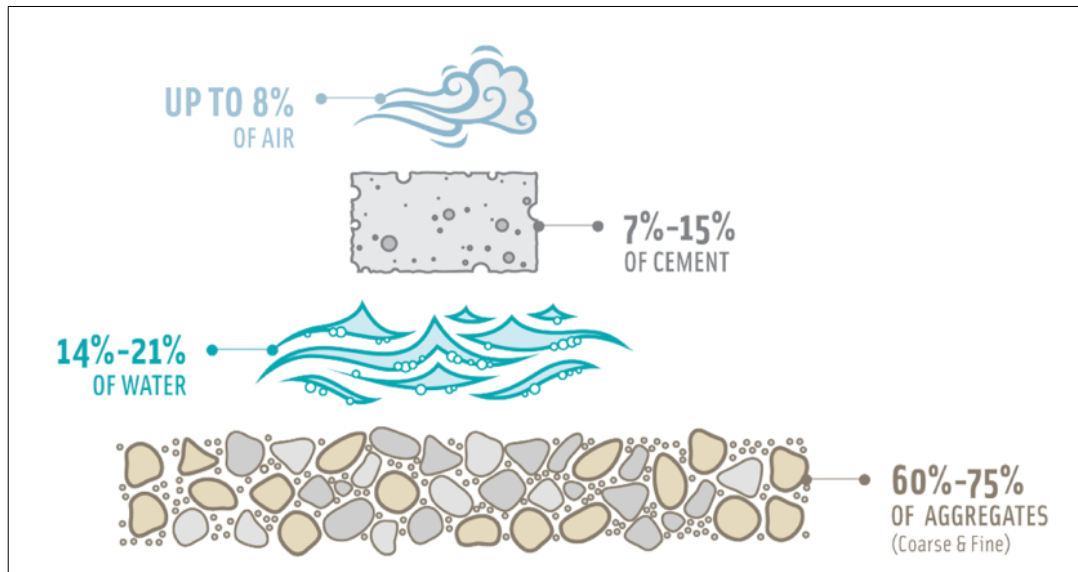

Figure 3: Components of Concrete, (America’s Cement Manufacturers, cement.org)

There are four basic forms of concrete to be produced which are ready-mixed concrete, precast concrete, cement-based concrete to be used for pavements and dams, and finally newly developed with the technological developments which incorporates fiber and special aggregates for making roof tiles, shingles and so on (America’s Cement Manufacturers, reached in 2023).

Concrete was most likely invented by the Romans in antiquity. The term hydraulic cement, which has originated in Latin, refers to a substance that solidifies in water. A cement made by combining ingredients including silica, alumina, and iron oxide is known as Portland cement (Neville, A. M., & Brooks, J. J. 1987). The material concrete has a stone-like appearance. The filler, or coarse granular material, is embedded in a hard matrix, the cement or binder, which fills the space between the aggregate particles and keeps them together (Li, Z., et al., 2022).

The most frequently used substance worldwide is concrete. infrastructures such as bridges, sidewalks, building frames, and many more. There are two types of material in concrete structure which is concrete and steel. The combination of steel and concrete and the amount of usage for each material is being calculated according to each project's specifications. Types of concrete can be differentiating according to the classification in accordance with unit weight, compressive strength, additives, or construction methods (Li, Z., et al., 2022).

The amount of usage of concrete material is leading the world to reconsider the end of life (EoL) scenarios of the material itself and the disposal procedures along with it. The world needs sustainable thinking architects to consider their designs accordingly. Both reinforced and non-reinforced concrete can be found as a type of waste form (Ponnada, M. R., et al., 2015).

### **2.1.3 Concrete as Waste Material**

Over 500 million tons of concrete, primarily made with ordinary Portland cement (OPC), are manufactured in the United States alone each year (Meyer, 1992). A ton of CO<sub>2</sub> is generated for every ton of OPC (Hanein et al., 2018; Hasanbeigi et al., 2010). Waste material resulting from the construction, renovation, and demolition of any structure, including roads, bridges, buildings, is referred to as construction and demolition (C&D) debris (Ganiron, T. U., 2015).

Numerous studies have shown that recycled waste materials can have a positive impact on greenhouse gas emissions because they minimize the need to extract aggregates from natural mines and lower CO<sub>2</sub> gas emissions from landfills. There are two types of recycled aggregates that can be used for both building material and road base material which are the recycled coarse aggregates (RCA) and recycled fine aggregates

(RFA). RCA is the one that is mostly used as building construction materials by the researchers and practitioners (Quedou, P. G., et al., 2021).

Sustainability and the lack of natural resources are the main reason for using recycled aggregates. There is a limitation on using recycled aggregate in structural concrete. The reason for that is the inherent deficiency of the concrete material. Recycled aggregates are weaker in comparison with natural aggregates (Parekh, D. N., et al., 2011).

#### **2.1.4 The Concept of Sustainable Concrete**

Since the turn of the millennium, Portland cement or its variants, which are its best commercially traceable and documented component, have had an amazing development that is only equaled by the immediate post-World War II period (Van Damme, H., 2018). Due to the characteristics of concrete such as being less expensive, being adaptable with complex building types etc., concrete is the most used material. It is being consumed around 6.5 billion ton annually (Vieira, D. R., et. al., 2016).

According to Coffetti, D., the environmental effect of concrete can be reduced by 50% however the performance can be decreased in terms of service life of the material. Fly ash and other industrial byproducts should be safely and profitably recycled by the concrete industry. Concrete's durability and energy efficiency increase when industrial byproduct, even up to 70% of them, replace cement in the mixture (Naik, T. R. (2008). In order to comprehend the material's potential to be recycled and reused, it is crucial to understand the life cycle of concrete. Figure 3 presents the concrete life cycle in detail. This graphic is the result of research by Mieke De Schepper and Philip Van den Heede on the life cycle assessment of totally recyclable, concrete. Beginning with the exploitation of the raw materials and ending with the recycling or disposal of the

crushed concrete, the design in Figure 4 considers the (beneficial) effect of avoiding the use of natural raw resources.

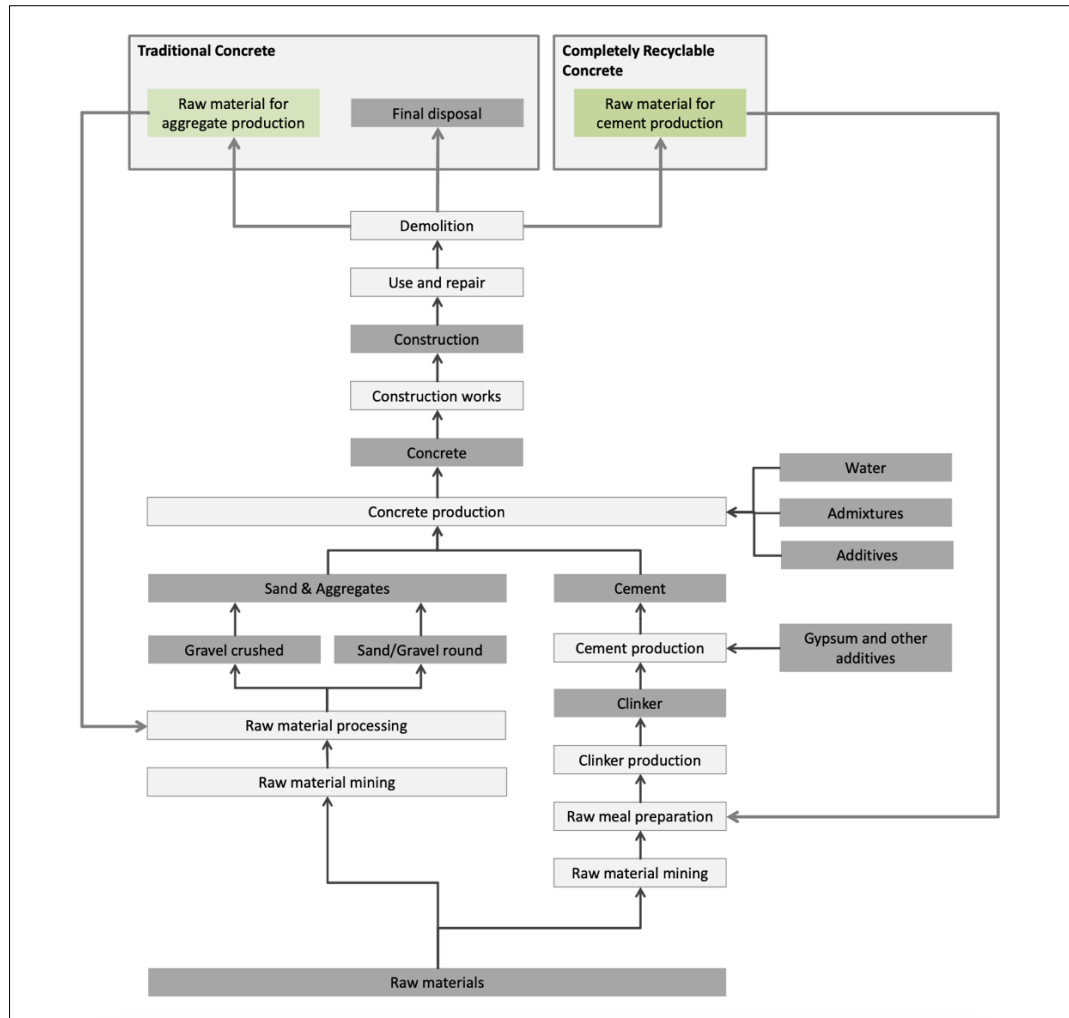

Figure 4: Life cycle of Concrete (De Schepper, M., Van den Heede, P., et al., 2014).

The recycling process of concrete is a massive topic to investigate. The process of recycling concrete has three main advantages. The first one is the need for new resources, the second one is it lowers the cost of consuming energy, and the third advantage is it recycles waste otherwise it would be sent to landfill (De Schepper, M., et al., 2014). Reduced environmental effect from concrete production is frequently the goal when aiming to make concrete more sustainable. An effective technique for

sustainability is to reduce the quantity of CO<sub>2</sub> produced, energy utilized, and natural resources used (Coffetti, D., et al., 2022).

One of the major solid waste sources is garbage from construction and demolition (C&D). End-of-life (EOL) concrete produced during demolition accounts for the largest portion of it. A significant way to reduce the amount of C&D waste is to recycle EOL concrete into useable products (Hu, M., et al., 2013). It is vital to consider the effects of each individual component in order to evaluate the environmental impact of the production of concrete. Typically, mining is used to get the aggregates. The mining of the coarse and fine aggregates occurs independently. On rare occasions, by-products of other processes such as recycled concrete, can be used to create aggregate (Struble, L. & Godfrey, J., 2004).

The primary components of old concrete are called recycled concrete aggregates (RCA), and their reuse is required for a variety of reasons (Oikonomou, N., 2005). Aggregate makes up 70 to 80 percent of the volume of concrete and have a big impact on how it behaves. They often consist of granular materials made from natural rock or sand and gravel. Concrete as a material, is being used for various reasons therefore the capacity of using the materials is too high that is why it is the most frequently used material around the world (Figure 4) (Parekh, D. N., et al., 2011).

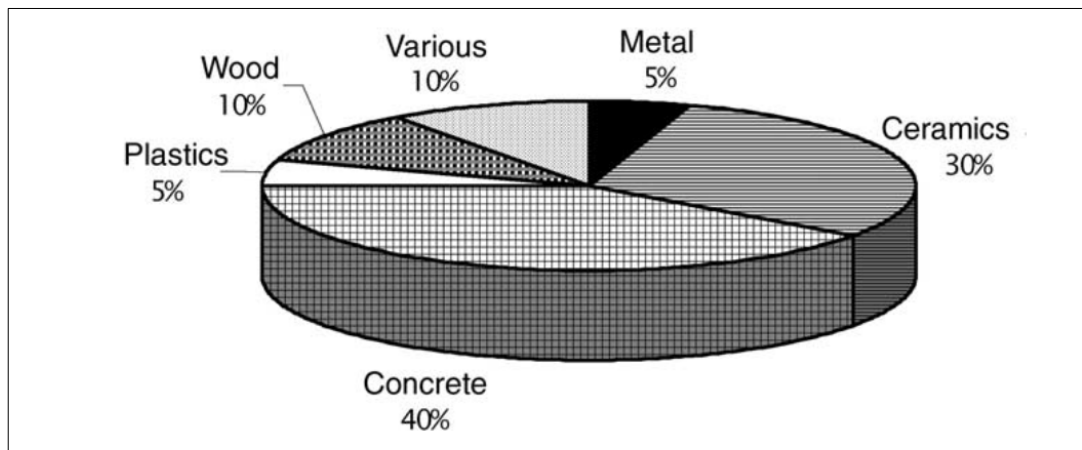

Figure 5: Basic composition of demolition wastes (Oikonomou, N., 2005).

Figure 5 shows the approximative proportion of different building elements in demolition waste (DW), using values that researcher (Oikonomou, N.) obtained (Oikonomou, N., 2005).

The sector must contend with rising resource prices, fierce competition from nations with low wages, and rising environmental laws particularly in Europe. Companies are beginning to investigate circular business models in response, and they are reevaluating how they create products (Bakker et al., 2014).

Product lifespan extension and reuse are effective strategies to address limitations in resources and the requirement to achieve zero waste. To prevent resource scarcity, recycling should only be carried out when remanufacturing or reuse are not feasible (Rios, F. C., et al., 2019).

Waste Framework Directive (WFD) of The EU is a turning point for contemporary waste management. The hierarchy of the waste management was one of the WFD's most notable contributions. The reuse of full structural concrete components is

exceedingly uncommon. According to Chunk Zhang (2021), as structural components, elements including beams, columns, walls, and floor slabs are frequently constructed to resist very precise loading, which restricts the options for reuse.

### **2.1.5 Waste Management Strategies**

The fundamental specialty of the construction industry demonstrate that it is not considered as a sector that counts as sustainable (Peng et. al., 1997). Circular economy is a great alternative that would eliminate loops in industrial ecosystems by using 3Rs concept, which stops trash from being produced and transforms waste into resources. In modern society, CDW is the main waste source that contributes to overall waste generation. CDW is rising in parallel with the current global urbanization (Zhang, C., et. al., 2021).

The purpose of a waste management system is to discourage overuse and promote material and component reuse. Reducing non-renewable waste and conserving natural resources are possible with efficient building waste management. Waste increases a lot to landfills, thus it's important to preserve the few resources available for landfills. (Yean Yng Ling, F., et al., 2013). The relationships between the various waste causing types are depicted in Figure 6. This implies that a comprehensive strategy to reduce project waste involves cooperation from all parties involved and considers not just the building phase but also the design and procurement stages (Ajayi, S. O., et al., 2014).



Figure 6: Interaction of the categories of waste causing variables (Ajayi, S. O., et al., 2014).

According to the study of Peng in 1997, there are six steps of the hierarchy of waste choices, which ranks environmental implications from low to high. These phases are reducing, reusing, recycling, composting, incinerating and landfill operations. Reuse, recycle and reduction are the strategies to be applied for waste minimization and reduction, and it is called as 3Rs strategy. The origin of Waste Hierarchy was developed in 1079 with the name of “Ladder of Lansink”. The 3Rs strategy has been developing ever since by the researchers according to the needs and technological developments. The evolution of the hierarchy of waste can be seen in Figure 7.

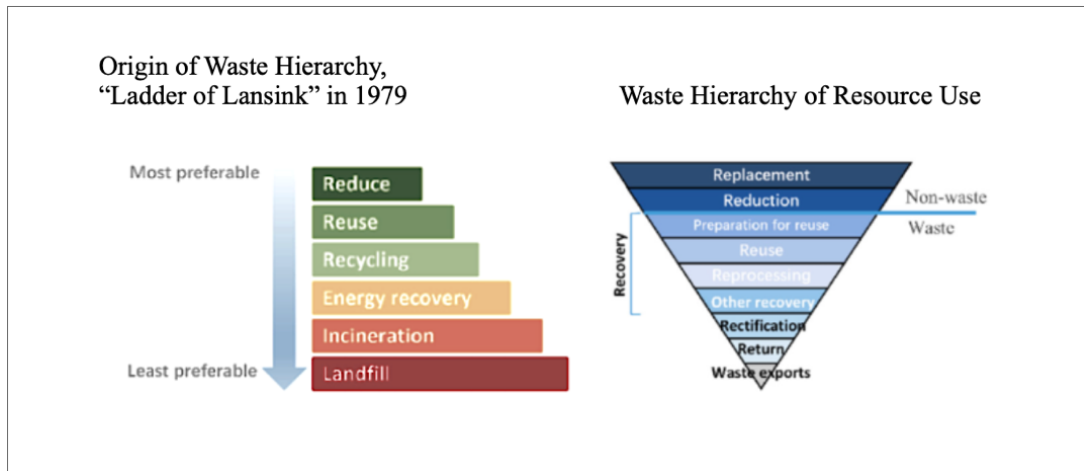

Figure 7: Evolution of Waste Hierarchy in Time (Taken from; Zhang, C., et. al., 2021).

In order to maintain resource value, a waste hierarchy should prioritize resource value preservation in addition to ecologically responsible waste disposal. The “Waste Hierarchy of Resource Use” was developed to drive resource effectiveness into waste hierarchy of resource use, as depicted in Figure 6.

## 2.2 Circular Economy Concept

The circular economy, as defined by the Ellen MacArthur Foundation, is a system in which nature is replenished and materials never go to waste. Products and resources are kept in use in a circular economy by procedures like reuse, renovation, remanufacture, maintenance, recycling, and composting. In the linear economy scenario, the products are being produced from the raw materials that comes from earth and finally being used and thrown away. The circularity in this sense, is creating a link in between the waste disposal and extracting of raw material processes.

The McKinsey Global Institute (MGI), a global management firm, and the Ellen MacArthur Foundation (EMF) released an evaluation study in 2012 at the WEF in Davos, Spain, to address the issue of transitioning from a linear economy to a circular economy (Ratum, A., et al., 2020). The idea of CE dates back to Boulding, who

described it as, an ecological system that can continuously reproduce material forms even though it must still receive energy inputs. Another approach to CE is a biomimetic approach to the design of products and systems, where biological and technical material cycles are separated, Cradle to Cradle (C2C) also has connections to the CE (Leising, E., et al., 2017).

The fundamental CE concepts of material and component reduction, reuse, and recycling have already been successfully applied to a wide range of products such as textile and furniture sectors. However, their use in building sector has started to be thinking recently and it is used to a lesser extent (Norouzi, M., et al., 2021). The focus is on the recycling and preventing the waste production and eventually material management. The adoption of eco-friendly products and technologies has made the construction industry one of the three with the highest potential for implementing CE principal policies. Adapting the CE principle encourages the use of sustainable resources and reduces the amount of trash generated unnecessarily and waste that is disposed of in landfills. CE aims to minimize environmental consequences on all fronts, not only waste generation techniques. There are many frameworks linked to CE that have been created. The 10R framework, which includes the ten techniques of refuse, rethink, reduce, reuse, repair, refurbish, remanufacture, repurpose, recycle, and recover, might be used as an illustration of it (Muñoz, S., et al., 2022).

Ellen MacArthur Foundation has developed a diagram in order to understand the circular economy concept in a more detailed way. The CE system diagram in the Figure 8 is a butterfly diagram suggested by EMF based on the drawing of Braungart & McDonough, Cradle to Cradle (C2C). It consists of two main circles named technical cycle and biological cycle. The materials are being kept in the cycle for

reusing, recycling repairing and, maintenance processes. The biological cycle is basically the process of turning back to Earth by regenerating of biodegradable materials.

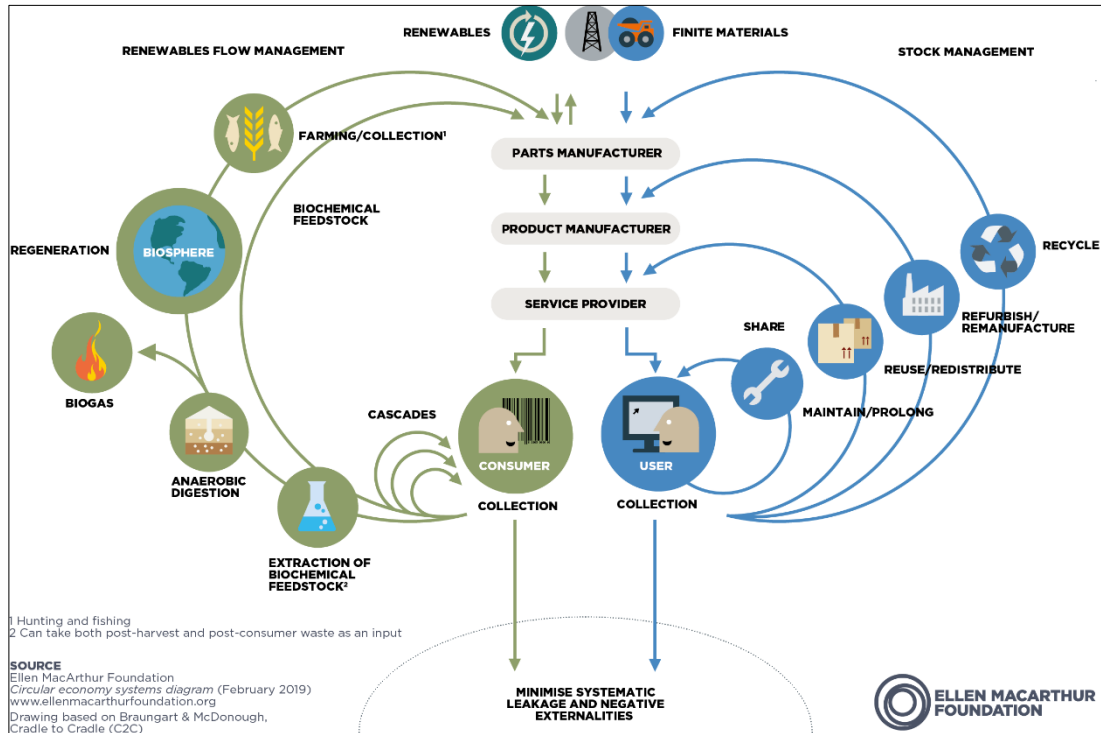

Figure 8: The butterfly diagram of CE, (EMF, 2015a).

It is a clear fact that construction industry is responsible for the major raw material loss, as well waste generation. Since waste management and waste reduction are not considered in the planning and design stages of a project, waste generated by construction and demolition (C&D) occurs throughout the life cycle of buildings (Benachio, G. L., et al., 2020). However, the end of life phase has the greatest impact on the generation of C&D waste, accounting for 50% of the statistics. This occurs because the majority of building materials are frequently disposed of at this stage because they don't have the ability to be reused (Akanbi et al., 2018). As EMF suggests in the general Circular Economy concept, end-of-life building materials should be reused and their components and parts disassembled in the Circular Economy models

in order to serve as material banks for new structures (Hopkinson et al., 2019). However, in order for this concept to be more widely used in the industry, knowledge and tools still need to be developed.

## **2.3 Building Circularity**

The main challenge for the current economic model can be accepted as the circularity understanding. According to UNEP explanation, circularity enables us to promote environmentally friendly production and consumption while making the transition to inclusive green economies. This is accomplished through reducing waste and pollution through intelligent design, preserving products and materials, and regenerating and expanding natural riches through economic and financial practices that value and support nature-based solutions. In order to have a more understanding on building circularity, it is needed to have a more explanation on Circular Economy (CE).

### **2.3.1 Building Circularity Principles**

The circular economy (CE) is gaining popularity among academics and business leaders, and efforts have been made to conceptually link CE with sustainability (Akanbi et al., 2018). The Ellen MacArthur Foundation (EMF) offered three essential concepts to help people comprehend the CE model (2015a). In order to dematerialize the design, the primary idea is focused on controlling finite resources and coordinating renewable flows. The second concept is that materials should always be used to the fullest extent possible in order to maximize resource outcomes. The last principle emphasizes lowering pollutant emissions and toxic chemical emissions (Zhai, 2020). (Figure 9).

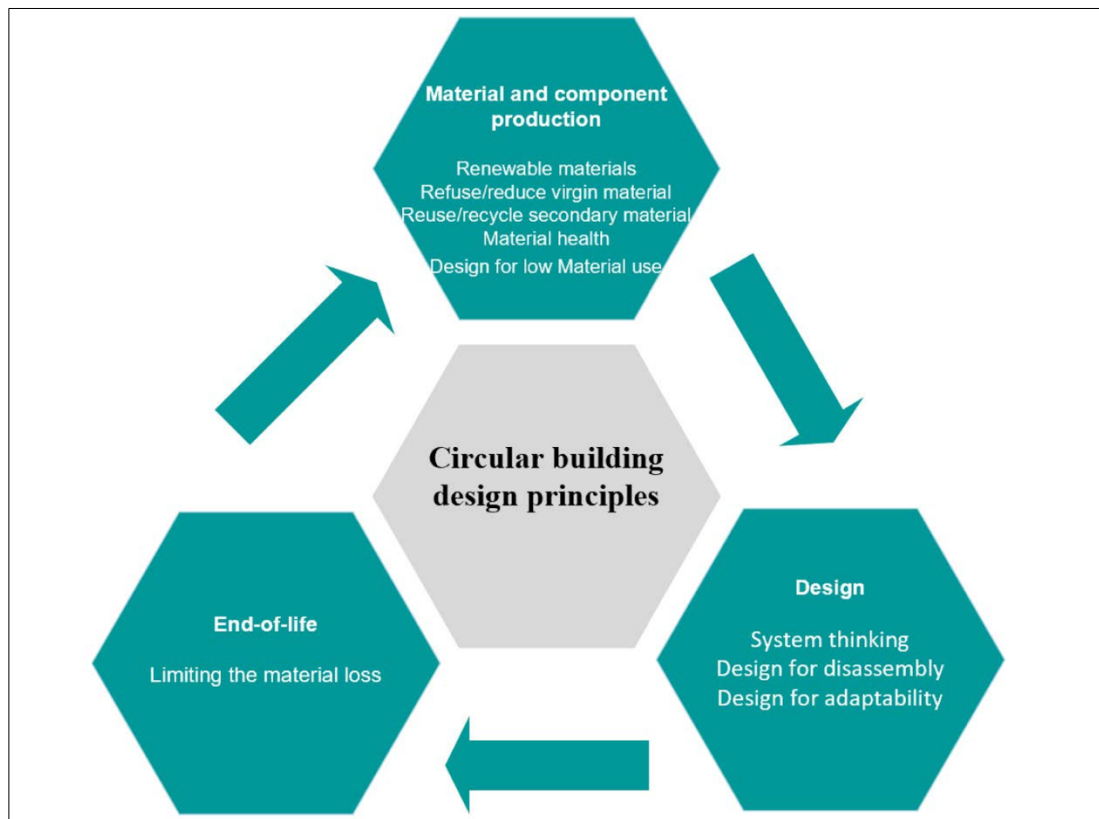

Figure 9: Circular building principles through life cycle (Zhai, 2020).

### 2.3.1.1 Material and Component Production

The material inflows for the technical life cycle of the building are primarily determined by the stage of material and component manufacture. Numerous studies have emphasized the importance of choosing sustainable materials (Verberne, 2016). Another design guideline to follow is to utilize less virgin materials or to avoid using them altogether. It should be more advantageous to choose or use secondhand material (Circle economy et al., 2014). Another factor to take into account is the reuse or recycling of secondary materials. In terms of toxicity brought on by demolition activities, material health should also be taken into account (EMF, 2015a). Another consideration is designing with minimal material usage. It attempts to utilize less resources and can help reduce raw material extraction, CDW generation, and adverse environmental effects (Rijkswaterstaat, 2015).

### **2.3.1.2 Design Stage**

Over time, several structures may have components in common. A dynamic structure based on the split of its pieces and relationships between those elements may be created by using the system thinking technique (Zhai, 2020). The value of implementing a "systematic thinking approach" on a circular architecture is emphasized by system thinking. Based on the hierarchy of a building's material composition, several levels can be identified (Bakx et al., 2016).

Another aspect is design for adaptability (DfA). Extending the service lives of buildings is possible via the use of "Design for Adaptability" (DfA), which allows construction materials to be used for longer. Buildings should be flexible and adaptive to the changing demands of its inhabitants and environments in order to increase construction lifetime (Kuiiri, L., et al., 2022). The main objective of design for adaptability is to extend a building's lifespan by enabling space adaptation with the least amount of damage. By making it easy to change the space with little disruption, design for adaptability's main objective is to extend a building's lifespan (Melton, P., 2020).

The other principle is Design for disassembly (DfD). It permits parts to be dismantled at the end of a building's useful life and then rebuilt in a different place, for the same project or for a different one (Kuiiri, L., et al., 2022). Through reuse, repair, remanufacture, and recycling, the process seeks to maximize economic value while minimizing environmental effects. In order to accomplish the aforementioned, a DfD process entails creating the necessary assemblies, parts, supplies, building methods, and information and management systems. The DfD building design method takes into account safe biodegradation as well as energy recovery from materials. DfD makes

complete buildings flexible, convertible, addable, and subtractable. DfD may be able to prevent the demolition of structures completely in this way.

### **2.3.1.3 End-of-Life (EoL)**

The end-of-life stage mostly influences the production of a circular building used as a temporary material repository. By reducing material loss and maintaining the material value, this end-of-life design approach aims to manage the building's end-of-life efficiently (Zhai, 2020). By lowering material loss, limiting material loss intends to preserve the material value throughout the building technical cycles. Technical materials should be made to collect, reuse, or remanufacture waste rather than dispose of it at the end of their useful lives (Platform CB'23, 2019).

## **2.4 Introduction to Environmental Impact Assessment (EIA)**

The National Environmental Policy Act (NEPA) was the first piece of legislation to explicitly adopt the impact assessment process. The Act, which was a response to growing public and scientific concern about current environmental changes, established an environmental policy to guide the actions of those Federal agencies whose decisions had the potential to significantly impact people, communities, and the natural environment (Morgan, R. K., 2012).

### **2.4.1 Brief Information about EIA**

Transparency in the decision making process for a number of public and commercial projects is ensured through the Environmental Impact Assessment (EIA) approach. According to a broad variety of environmental parameters, such as demographic and wellness of people, ecological diversity, terrain, the climate, the soil, landscape, material assets, and cultural heritage, the EIA evaluates the direct and indirect major effect of a project (European Union, reached in 2023).

The goal of impact investing is to provide both a financial return and beneficial social and environmental effects. The primary focus lies in organizing global finance in a manner that promotes environmental restoration and social empowerment. This is a complicated procedure that necessitates a variety of technical abilities, an experience with assessment frameworks, and a strong scientific mentality to do an impact assessment. Nova is an example for evaluating environmental impact assessment. The figure 10 shows the social and environmental capabilities of impact assessment.

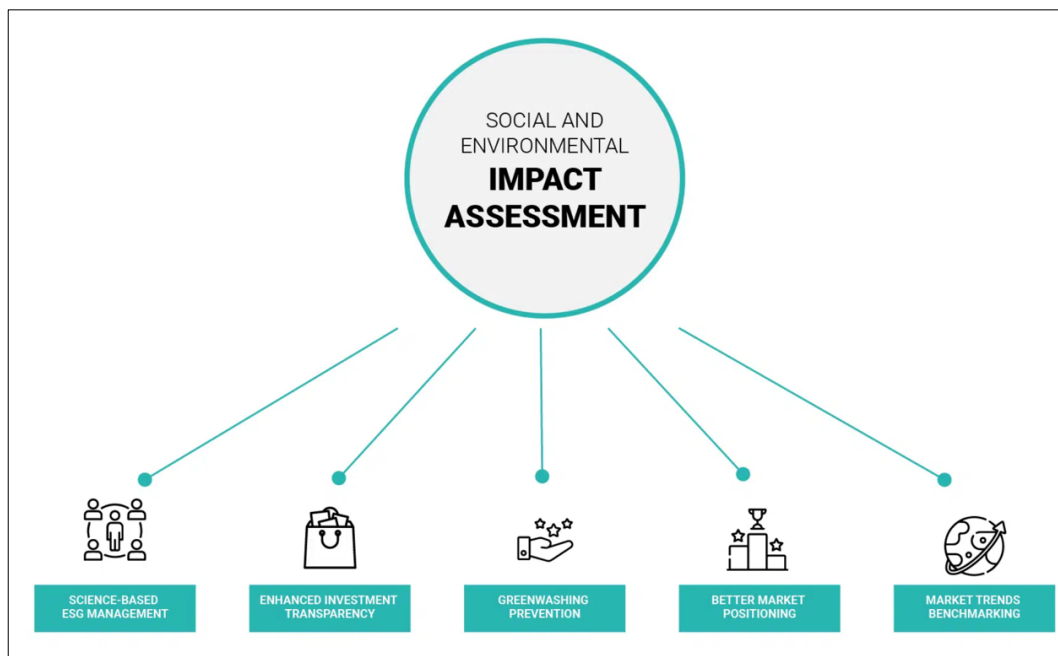

Figure 10: Environmental Impact Assessment (nuvasustainability.com, reached in 2023)

According to the investigations of European Commission (reached in June 2023), the environmental effect of large construction or development projects in the EU must first be evaluated according to the environmental impact assessment before the project is allowed to start. For a variety of projects, such as nuclear power plants, long-distance railroads, motorways, express highways, waste disposal facilities for hazardous waste, and dams with a specified capacity, an EIA is necessary.

According to a wide variety of environmental elements, such as population and human health, biodiversity, land, soil, water, air, climate, landscape, material assets, and cultural heritage, the EIA evaluates a project's direct and indirect major impacts.

The steps of an EIA process will rely on the needs of the nation or donor, according to the study by Dutta, B., and Bandyopadhyay, S. The first step of an EIA evaluates if the project under consideration needs an EIA and, if so, what degree of evaluation is necessary. The scoping step highlights the main problems and effects that require more research. Additionally, the scope and duration of the study are established at this step. The following phase is baseline analysis, which the validity of the impact evaluation and, by extension, of the EIA itself is established by the quality of the baseline study. The impact analysis phase of the EIA identifies, predicts, and analyzes the scope of the project's potential environmental and social impacts. The following stage is mitigation, during which EIA suggests taking steps to lessen and/or eliminate any potential negative environmental effects of development operations. The reporting phase gives the decision-making body and other interested parties a report including the EIA's findings. A brief yet thorough report is created (Figure 11).

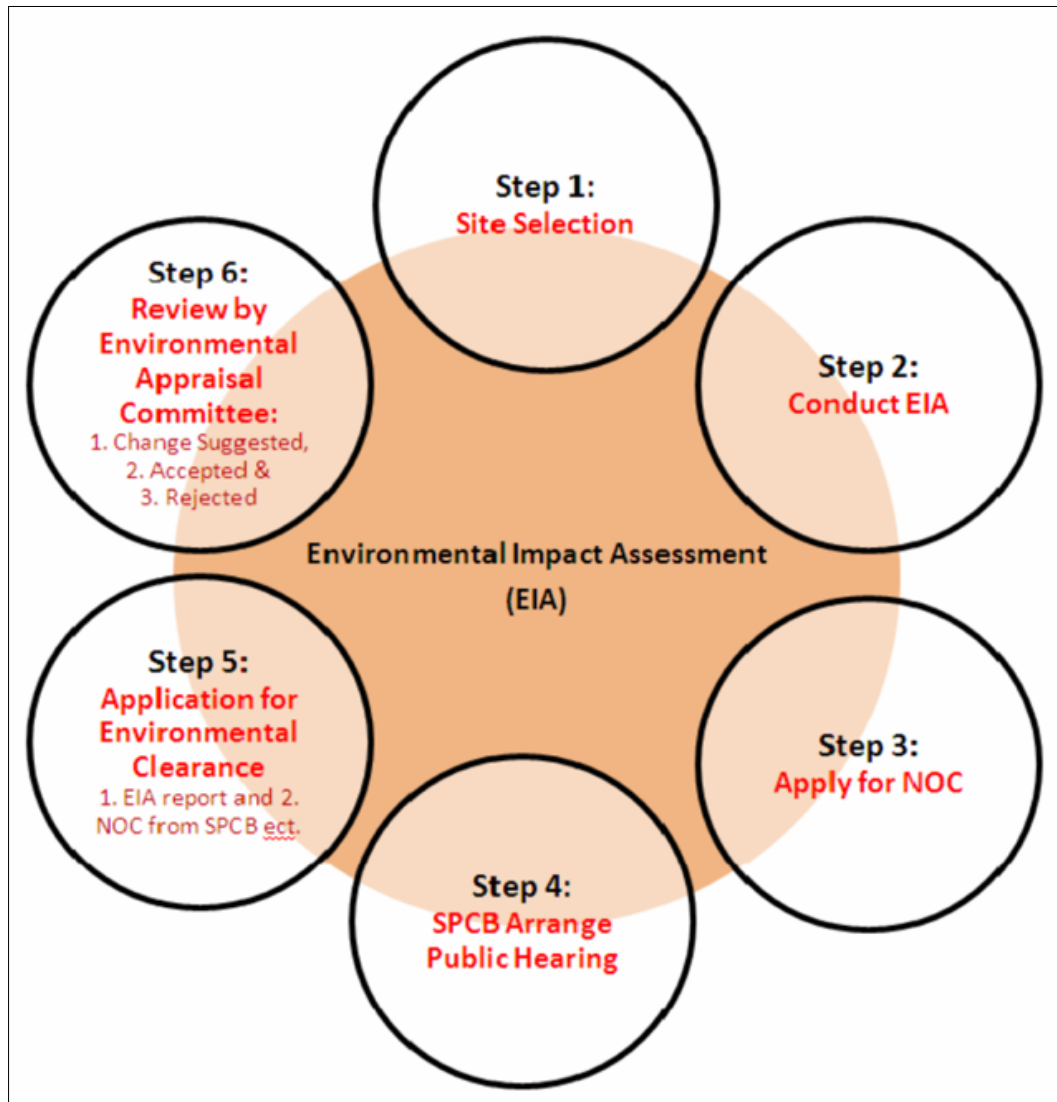

Figure 11: Entire Information Analysis Process Flow Chart (Dutta, B. K., et al., 2010).

#### 2.4.2 Life Cycle Assessment (LCA)

The study of the current environmental effects of items throughout their life cycles is known as life cycle assessment (LCA). This cycle comprises activities like the extraction of raw materials, manufacture, application, and utilization, and recycling or disposal at the ultimate end (Taygun, G. T., & Balanli, A., 2007).

Tukker declares in the study (1999) that, LCA is more comprehensive approach compared to the Environmental Impact Assessment (EIA). This is supported by the

following from the LCA's fundamental definition as life cycle assessment is a technique for assessing the environmental aspects associated with a product over its life cycle.

The life cycle of a building, which includes its construction, use, and deconstruction, accounts for close to 50% of all energy consumption in the European Union and over 50% of all CO<sub>2</sub> emissions (Vieira, D.R., et. al. al., 2016). The term "life cycle assessment" refers to a method that may use to provide supporting tools in projects to analyze the environmental effect of goods and processes across their full life cycle while giving conclusions that are both comprehensible and supported by science.

A systematic approach for undertaking an environmental analysis of industrial processes was defined and highlighted in the ISO 14040 standard, which underwent its last upgrade in 2006. A building is made out of a variety of durable, one-of-a-kind components, unlike other industrial operations. Since the ISO standards merely offer guidelines, it is quite challenging to apply LCA in building projects (Safari, K., et. al., 2021). Life cycle research have changed throughout time in concept. Life cycle studies in the 1970s and 80s focused mostly on calculating how much energy, materials, and trash were used and released into the environment over a product's life cycle.

According to Figure 12 (Sharma, A., et al., 2011), the four phases of the life cycle assessment (LCA) technique are aim and scope definition, life cycle inventory analysis, life cycle impact assessment, and life cycle interpretation.

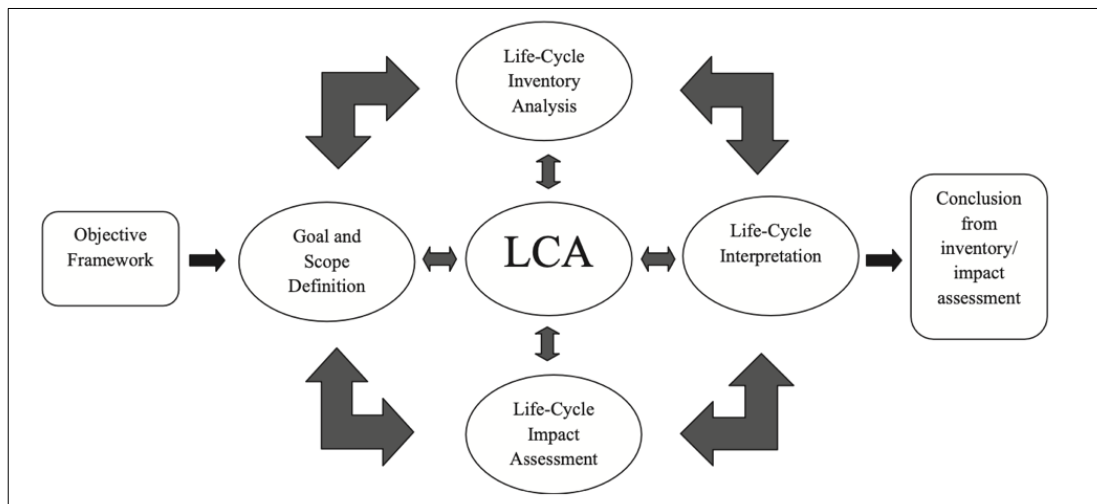

Figure 12: Stages of Life Cycle Assessment. (Sharma, A., et. al., 2011).

Four steps are typically present in an LCA investigation. Goal and scope definition is the first stage. The second stage is the Life Cycle Inventory (LCI) Analysis, which compiles information on the consumption of resources, including energy, as well as on emissions into the environment during the course of a product's life cycle. The third stage, Life Cycle Impact Assessment (LCIA), involves a possible impact evaluation of the indicated resource usage and environmental emission patterns. The fourth stage of the study, Interpretation of results, is when the data from the previous phases are interpreted in light of the goals of the investigation (EEA, 1997).

The goal and scope definition are the first step of the LCA. It indicates a few concerns which are determining the goal and scope, system boundaries and so on. This phase is vital because the assessment should start with a goal statement. All types of LCA studies require transparency. The boundaries of the assessment, what is included in the system and what specific assessment techniques are to be used by the description of the life cycle assessment's scope (EEA, 1997).

A complex procedure known as the life cycle inventory (LCI) evaluation aims to acquire and analyze basic and intermediate flow data at different points in the life cycle of product systems (Safari, K., et al., 2021). The LCI is a collection of all mass flows and emissions related to system-wide waste management operations as well as upstream and downstream waste management-related activities. This provides comprehensive details on different waste kinds, their distinct material components, and in certain circumstances, their precise physicochemical makeup (Christensen, T. H., et al., 2020). The LCI involves data collection on the 'cradle-to-gate' energy and resource requirements as well as the output implications on environmental degradation related to the manufacturing of raw materials and water supply systems (Kylili, A., et al., 2015).

The aim of the life cycle impact assessment (LCIA) phase, which establishes the scope and focus of the research (Vieira, D. R., et al., 2016), is to comprehend and analyze the impacts on the environment based on the inventory analysis. It covers the following crucial topics: characterizing, classifying, defining categories, and assigning values and weights. The process of characterizing and evaluating the consequences of the environmental actions included in the inventory table involves both quantitative and qualitative methods, known as impact assessment (Heijungs & Hofstetter, 1996; EEA, 1997).

This last phase of LCA combines the results from impact assessment and the inventory analysis in a way that is consistent with stated goal and scope to arrive at conclusions, clarify limitations that might pose a challenge to the initial goals (Vieira, D. R., et al., 2016). The identification of key environmental concerns, evaluation, conclusions, and

recommendations are the four primary topics that make up the interpretation part of a life cycle assessment (ISO, 1997d; EEA, 1997).

There are many application tools related with LCA such as Ecochain, SimaPro, Athena, Lucas, Ecological Footprints, One Click LCA and so on. The LCA programs can be categorized according to following approaches: problem-oriented approaches, damage approaches, mid-end point tools, and other. In this thesis, One Click LCA program will be used for assessment of concrete reusability and recyclability.

#### **2.4.3 Life Cycle Assessment Tools in Use**

The Life Cycle Assessment is a method for assessing the environmental impacts of a product or a building for this thesis, as it is demonstrated above in a clear way. Using LCA for systematic evaluation as an analytical methodology for environmental impacts assessments is effective for all stages of a products of buildings life cycle. According to the study that Han, G. and Srebric, J., conducted, there are many LCA tools to be used in the market according to the specific requirements and needs of the users. The life cycle cost of buildings, economic costs, and environmental performance of products of buildings is under the standards of ISO 14040 series. BEES, ATHENA EcoCalculator, ATHENA Impact Estimator, SimaPro and One Click LCA are one of the well-known programs for life cycle assessment.

BEES stands for Environmental and Economic Sustainability software. It was developed by the United States EPA Engineering Laboratory. The analysis that BEES does includes transportation, manufacture, use, recycling, waste management and so on.

The ATHENA Sustainable Materials Institute created the LCA applications Athena EcoCalculator and Impact Estimator. For building materials and goods, transportation, and demolition operations, reliable life cycle inventory databases offer precise scientific cradle-to-grave data. The usage of EcoCalculator creates a spreadsheet tool for a rapid, approximate estimation of the building design footprint since it is quick but has few design possibilities. For more thorough and precise estimation of a building's footprint, the Impact Estimator program is versatile (athenasmi.org, reached June 2023).

SimaPro is another LCA tool which is developed by Marc Goedkoop who is an eco-designer and the founder of 'PRe Sustainability'. With the help of programmer Vincent Cleij and CML Leiden, SimaPro become one of the market-leading software. SimaPro can analyze sustainability performance with LCA, gives fact-based sustainability reports that creates a communication tool, and constitutes Environmental Product Declarations (EDP). It is available in desktop version, which is supported with cloud database. (pre-sustainability.com, reached June 2023).

One Click LCA is another method to measure the LCA of products or buildings that is going to be explained in detail in 2.3.3.1 sub-section.

#### **2.4.3.1 One Click LCA Program**

Bionova Ltd. released a program called One Click LCA. The program was created to determine the environmental footprints of building projects and goods, and quantity surveyors, structural engineers, architects, and environmental consultants are the main users of it. Apart from life cycle assessment (LCA), the program offers options for tracking environmentally friendly materials, monitoring sites, preparing for climate change, reducing emissions throughout usage phase, and evaluating infrastructure

projects. The program's specialization in building life cycle assessments (LCA) and support for green building rating systems like LEED and BREEAM are the main reasons this tool was chosen for the study. The software's speed and user-friendly interface are its key advantages, as LCA often requires a significant amount of time and work to complete.

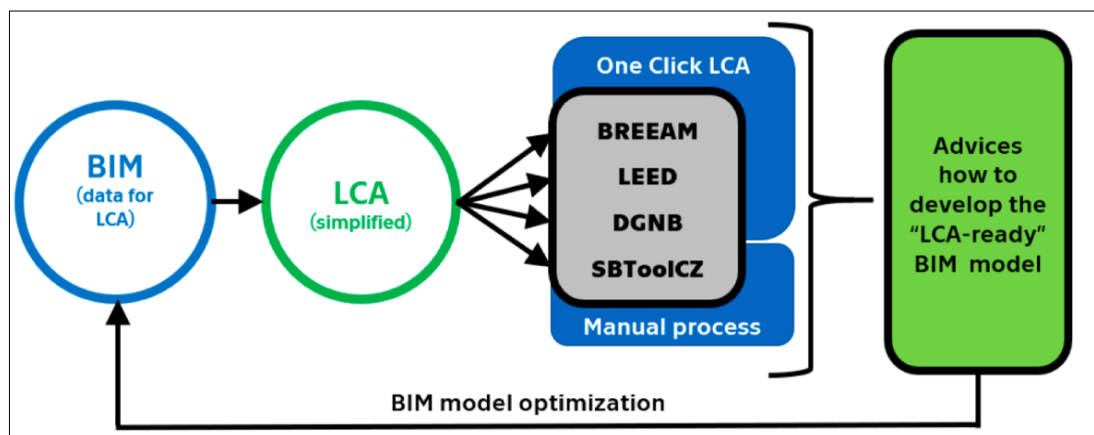

Figure 13: Workflow of LCA tools with BIM (Vaselka, J., et al., 2020).

## 2.5 Building Information Modelling (BIM) and LCA integration

Building information modeling is an integrated method that supports whole-life management of the facility from design to operation by combining the creation and use of a computer-generated parametric model of a building (Akanbi, L. A., et al., 2018). Architectural and structural design and detailing, especially in modular construction, have found widespread acceptance among academics and industry partners of BIM. These applications make use of BIM's 3D visualization capabilities as well as its ability to plan and manage many construction sectors simultaneously, including the structural, architectural, mechanical, and electrical sectors (Akbarnezhad, A., et al., 2014). Building information modeling (BIM), as defined by Krygiel and Nies (2008), is the process of creating and managing building information during the course of a building's service life.

Building data integration and the advancement of planning, designing, building, managing, and recycling throughout the various stages of a construction project's life cycle are the goals of this successful generation of information technology for the construction industry (Najjar, M., et al., 2017). See Figure 13.

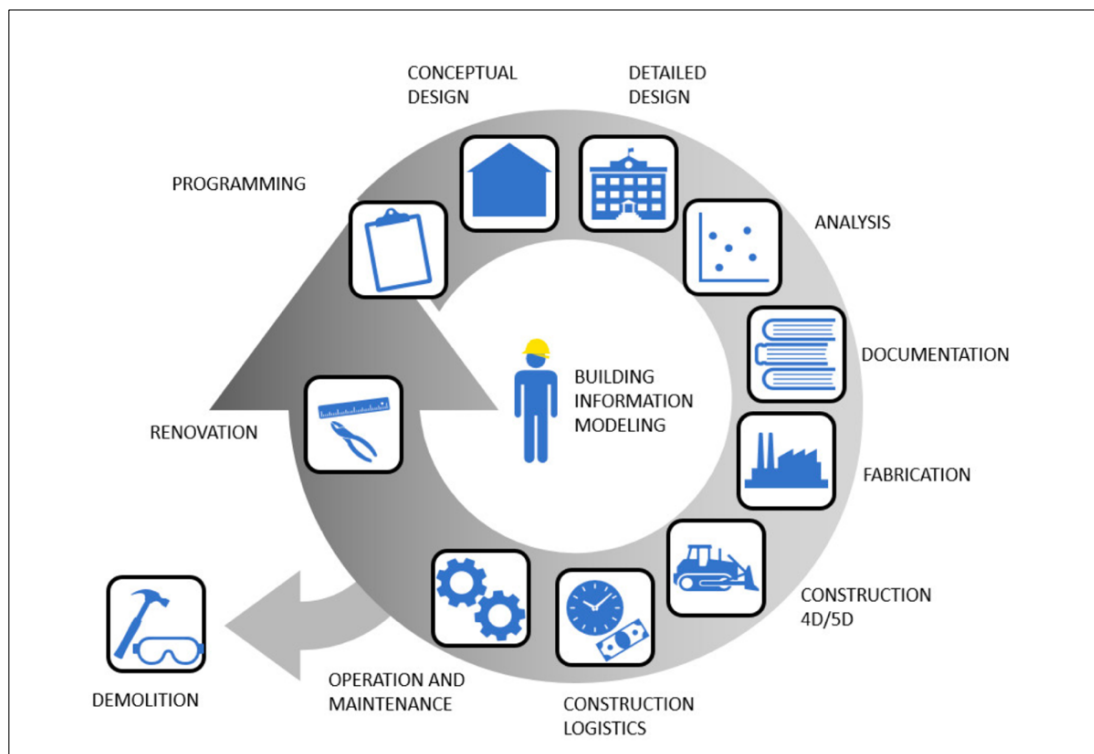

Figure 14: Building Information Modelling (BIM) applications across buildings' lifecycles (Alhamami, A., et al., 2020).

BIM is a method that generates and keeps data and information about the built environment throughout its whole life cycle, from concept design to disposal, as it is depicted in figure 14.

When it comes to scheduling, estimating, sustainability, and facility management, BIM can provide multi-dimensional representations and analyses ranging from 3D modeling to the integration of all relevant building component information (Bakchan, A., 2019). Waste produced by building and demolition operations, including

renovation and deconstruction, is referred to as such. The term also covers surplus and damaged items and materials that are produced during construction or that are momentarily utilized during on-site operations (Ponnada, M. R., et al., 2015). Waste management includes waste collection, transportation, storage, handling, recycling, and disposal.

Recently, BIM, a developing technology, has been receiving significant attention globally (Safari, K., et al., 2021). BIM enables energy-efficient design when assessing energy use across a building's whole life cycle. Numerous researchers have recommended using BIM tools in combination with the Life Cycle Assessment (LCA) approach to evaluate the environmental impact of the building industry in particular. To achieve this integration, the sustainable design process and the decision-making process might be combined (Najjar, M., et al., 2017). From time of resource extraction and manufacturing, building construction, and operation, through waste recycling, LCA assesses the environmental effects of various goods and services, including buildings. Additionally, LCA is frequently used to choose a more ecologically friendly choice and to advance the idea of sustainability in the building sector (Safari, K., et al., 2021).



Figure 15: Integration of BIM and LCA. (Naneva, A., et al., 2020).

Consequently, it is thought that combining BIM and LCA is a critical problem for meeting sustainability requirements in the building industry and protecting the environment. Such integration might greatly benefit the sustainability sector (Najjar, M., et al., 2017).

### 2.5.1 Definition of BIM

The whole process of generating and maintaining information for a constructed object is known as building information modeling, or BIM. Building Information Modelling combines structured, multidisciplinary data, powered by an intelligent model, and facilitated by a cloud platform, to create a digital depiction of an asset at every stage of its lifespan, from planning and design through building and operations (autodesk.com, reached in 2023). The Architectural, Engineering, and Construction (AEC) sector recognizes Building Information Modeling (BIM) as a significant development. BIM has been gaining in popularity over the past few years, and CWM

is one area where BIM applications are growing; examples include automated CW estimate, waste minimization, and disposal planning (Guerra, B. C., et al., 2020).

#### **2.5.1.1 Autodesk Revit as Selected BIM Software**

Architects, landscape architects, structural engineers, mechanical, electrical, and plumbing (MEP) engineers, interior designers, and contractors may all utilize the BIM program called Revit. Charles River Program created it in 1997. In 2000, it underwent a redevelopment and changed its name to Revit Technology Corporation. In 2002, Autodesk purchased it.

With the aid of the program, users may create 3D models of buildings and their structures, add 2D drafting parts to the models, and get building data from the databases of the models. A 4D program for building information modeling, Revit provides capabilities to plan and monitor a structure's lifetime from conception to construction, and thereafter maintenance and deconstruction.

Autodesk Revit, a BIM platform, is integrated with LCA tools and software, providing a wonderful chance for reliable and easy calculations.

#### **2.5.1.2 Autodesk Revit and One Click LCA Integration**

The goal of incorporating the BIM approach into the LCA calculation is to streamline the workflow and enable LCA optimization at early design stages. Furthermore, longer, and more complicated life cycle assessments may be completed with greater efficiency, which lessens effort and promotes life cycle assessment performance (Forth, K., et al., 2019). Figure 16.

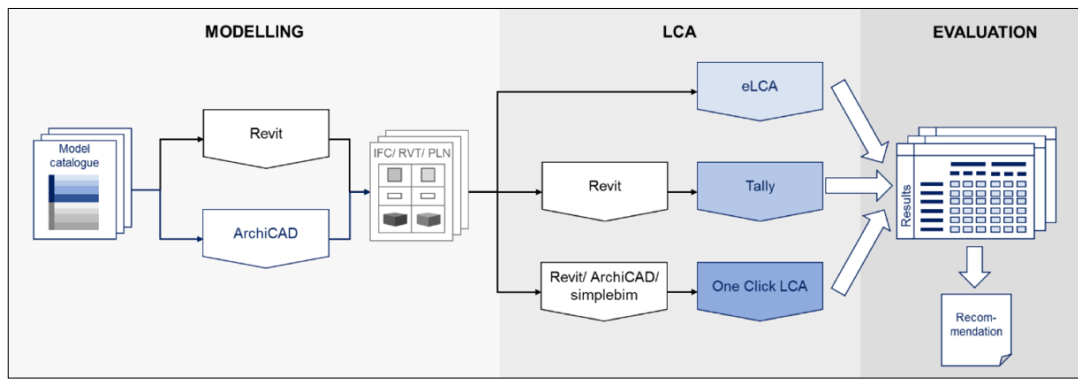

Figure 16: BIM integrated LCA workflows. (Forth, K., et al., 2019).

Figure 16 is demonstrating an example workflow for BIM-LCA integration. The so-called workflow demonstrates the three main phases. The first phase is the modelling, which requires a BIM program such as Autodesk Revit or ArchiCAD. The second phase is the LCA integrated part which there will be another program or plug-in that is giving comprehensive analysis of the building that is drawn by BIM program. LCA programs can be either a separate program which needed to be downloaded as a software or it can be a plug-in or add-in to the BIM program. The last phase is giving the evaluation reports from LCA tools. The report includes building's life cycle impact that is obtained from datapoints that specific LCA analysis provider. After the usage of filters during the analysis phase, it is also possible to achieve results of material EPDs or generic data. Benchmarking all the material in database is also giving chance to find the lowest impact materials in the report. The evaluation phase is also giving certification reports with the help of add-on compliance tools such as BREEAM, LEED, HQE, C+E-, and so on. Life cycle costing, early design optimizations, building circularity, or infrastructure carbon and LCA are the many features it can give to the user with LCA analysis.

## **Chapter 3**

### **CASE STUDY AND THE METHOD**

#### **3.1 EMU, Faculty of Architecture, Office Building as a Case Study**

##### **3.1.1 Locational Analysis**

One of the most significant coastal cities in both the Mediterranean Sea and the Turkish Republic of Northern Cyprus is Famagusta. The city also can be accepted as tourist and education center. The development of Famagusta started with the Lusignan period and continued with Roman, Eastern Roman Empires, Latin Kingdoms, the Venetians, and Turks. Cyprus island has divided in to two parts due to the political conflicts in between the Turkish Cypriots and Greek Cypriots. Today, the northern part of the island is accepted as Turkish Republic of Cyprus (TRNC). Asia, Europe, Africa is the continents that surrounds the Cyprus Island in the middle of Mediterranean Sea (Figure 17).



Figure 17: Location of Cyprus (googleearth.com, reached June 2023).

The climate of Cyprus island is Mediterranean, and accordingly the summers are hot with high temperature and humidity. Winters are mild with high prevailing wind effect. Kyrenia (Girne), Nicosia (Lefkosa), Iskele and Famagusta (Gazimagusa) are the most developed cities of Northern Cyprus. The borderlines of the cities can be observed in Figure 16. Famagusta is facing towards to the eastern countries such as Syria, Lebanon. Most of the cities of Northern Cyprus is well known for its historical backgrounds as well as valuable established universities. Gazimagusa is home to the Eastern Mediterranean University (EMU), which is the first and only governmental institution (Figure 18).

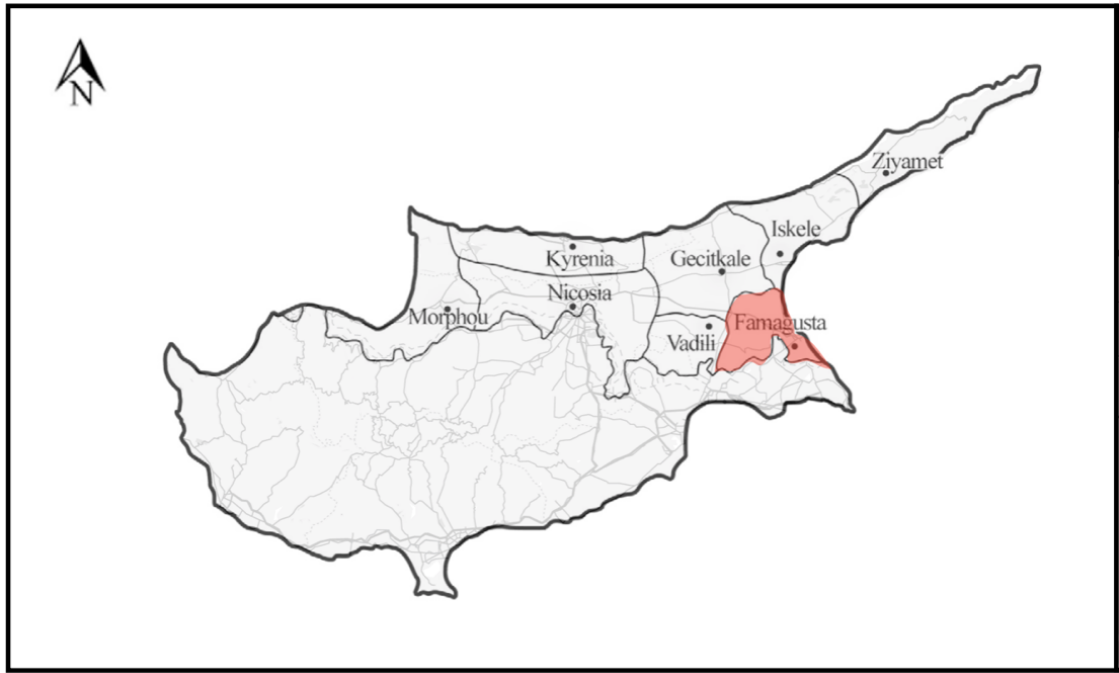

Figure 18: Division of the cities of TRNC (Graphic by author).

### 3.1.2 Brief Information about EMU, Faculty of Architecture

In 1979, the university was established, and it offers a research infrastructure within 210 programs that grant undergraduate and graduate degrees in total. There are 12 faculties, 4 schools, and Foreign Languages and an English Prep School. EMU is a campus university spread over 3000 acres (3000 m<sup>2</sup>) of land (Figure 18).

Selected building as a case study is from the campus of Eastern Mediterranean University (EMU), the Faculty of Architecture's Office Building. EMU's Architecture Faculty is established in 1990 and located in the North Campus of EMU.

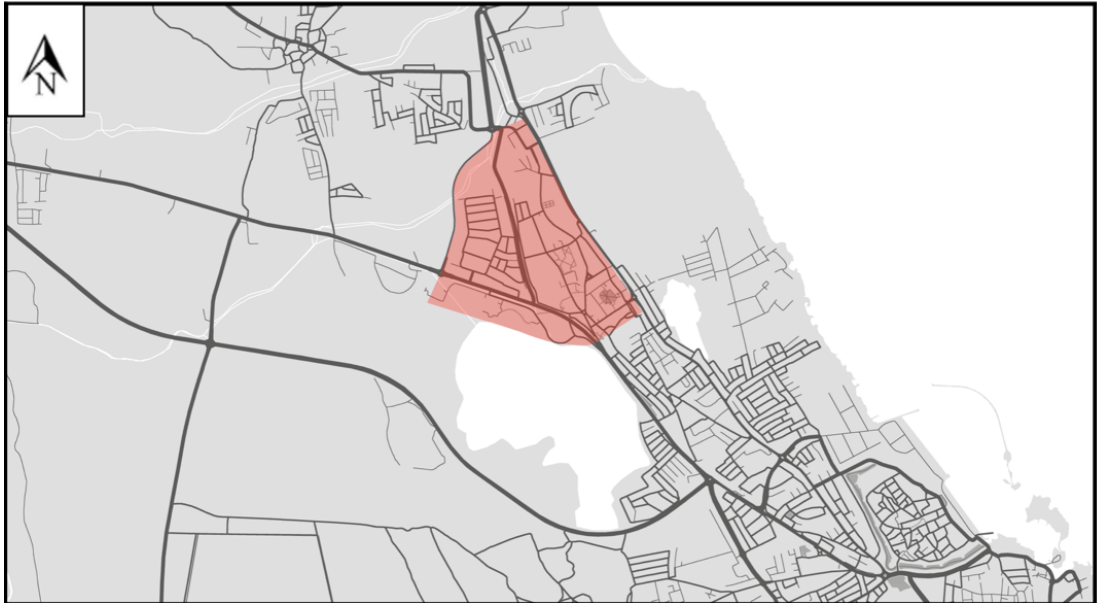

Figure 19: Borders of Eastern Mediterranean University (Graphic by author).

There are 3 type of buildings which are separately designed in terms of functionality. There are two buildings which are clustered are the studios for mainly design courses. Another one is the Colored Building which is three-story mixed used building that is being used for both design courses and theory courses. And the last one is the Office Building for academic and administrative purposes (Figure 20).

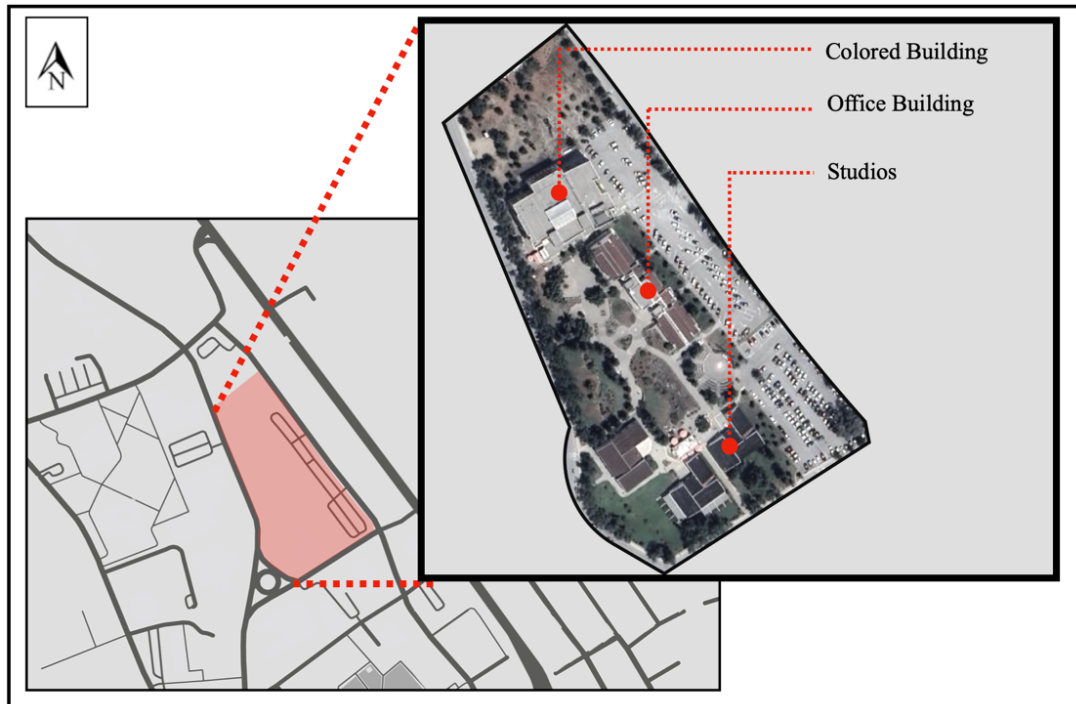

Figure 20: Borders of Faculty of Architecture, EMU (Graphic by author).

The Office Building is a three-story, rectangular building, which located in the middle of all other buildings belong to Architecture Faculty. Total area of the building is 2280 meter square. There are administrative offices for architecture and interior architecture departments, deans' office, seminar rooms, research room, kitchenette, shared offices for research assistants and individual offices for academic staff.

North-east longitudinal façade of the building faces the car parking for academic staff, while the south-west longitudinal façade if facing the courtyard and gathering point of the Faculty of Architecture. The building has four entrances, two of which are on the parking lot side and two of which are on the courtyard side.

The office building takes place in the faculty of architecture site. There are many buildings in the site that are belong to the faculty of architecture. Colored Building are

for general lectures. There are studios for design classes mainly. There is another building that has the computer labs and construction labs.

### 3.1.3 Detailed Information about Office Building

The Faculty of Architecture ‘Office Building’ is inside EMU campus. The campus’ gross area is massive therefore each faculty has a lot of space as open-public spaces. The building is in 3 floor heights (Ground Floor – First Floor – Second floor) and the 4th floor is for the access to roof for maintenance purposes. The construction system is reinforced concrete frame system. Cyprus has intense Mediterranean climate, or in a more detailed way, it can be explained as semi-arid climate according to the data of weather and climate webpage results. The summers are too hot and dry while winters are relatively mild and has some rain in between December and February months. Accordingly, the roof type of the office building is a steep roof, where Cyprus’ main roof type is a flat roof due to the climatic reasons.

Figure 21 demonstrates the exact location of the office building within the borders of faculty of architecture in EMU.



Figure 21: EMU (left) – Office Building (right) location. (Obtained from google earth, 2023).

### **3.2 Method of the Study**

The research study provides a BIM-based LCA approach to evaluate the possibility of reusing and/or recycling reinforced concrete material within components of buildings that have reached the end of their useful lives. The building model was created with Autodesk Revit. This program was used to design the building's structural components, including beams, columns, footings, and other aspects that consist of concrete material. Building elements' individual specified materials for the building were assessed for circularity using the One-Click LCA program. The building circularity score reflects the entire material circularity, including both the project's usage of materials and the treatment of end-of-life materials. It is measured as the average of "materials recovered," which refers to the project's usage of recyclable materials, and "materials returned," which measures how successfully items are returned rather than disposed of or devalued.

The Office Building of EMU, Faculty of Architecture has reinforced concrete frame structure. The building components to be evaluated in terms of building circularity with One Click LCA tool is selected according to the specific material which is reinforced concrete. The Calculations will be obtained by the complex selection opportunity of the selected tool. The tool allows to select components individually to be assessed in terms of end-of-life scenarios. The key choice for this study is the material's end-of-life processing chain selection. The whole material flow will be treated using the chosen processing chain during every phase of the life cycle, in accordance with the selection. When C1 is expected to be deconstructed, this decision affects the implications for life-cycle modules C and D, if applicable. The comparison will be done according to the created designs individually in terms of building

structural elements, therefore the One Click LCA Program itself will calculate the outcomes according to the data given.

The end-of-life modelling methods is developed by One Click LCA tool, and the user's choice is being made in LCA parameters query. The application is valid for the whole project or selection according to the user's selections. The selections of materials for each component are defined country-based to be able to get the accurate results in terms of so-called countries' waste management systems. Most of the Europe countries are considered to have a fine waste management system with efficient landfill taxes and recycling rates. The landfilling taxes and the waste management regulations are not sufficient in Middle Eastern countries. Most of the materials that has reached to its end-of-life are being landfilled by default without any recycling or reusing implementations. The One Click LCA program is giving the chance to adjust the options according to the countries that is available in the database. The system is allowing to choose the desired data from "EOL Process" such as Use EOL defined in EPD (Environmental Protection Department), Reuse as Material, or Concrete Crushed to Aggregate, and many more according to the materials life-cycle process.

Building circularity may be measured using embedded algorithms from One-Click LCA. The online help section of One-Click LCA offers comprehensive information on building circularity calculations. The applications listed above are used to investigate the office building chosen as the case study. Average information level is included in the depicted building. The information level of design is chosen in accordance with the elements that will be used to the One Click LCA evaluation technique.

The foundation, columns, beams, floor, and slab elements are among the components that were chosen based on how much concrete was included in them. Plans, sections, elevations, and additional information including energy consumption models are used to determine the precise measurements and proper information about the building obtained from EMU's project management department.

The Autodesk Revit add-in application is called One Click LCA. Following the completion of the project drawing, the materials are entered into the Autodesk Revit application for One Click LCA evaluation. The application requests further information pertaining to the active project after the data have been sent from Revit LCA to the One Click LCA Cloud system. The One Click LCA Cloud system has a variety of calculation framework based on different country-based standardizations. For this study, building circularity and level(s) life-cycle assessment (EN15804 +A1) are both selected. The method and standardization are set automatically to Levels EU. The project type is selected as component evaluation only according to the information level of design. The calculations are done by the program and the results are given according to the information are given to the program. The results' complexity is increased according to the level of information given to the LCA database.

### **3.2.1 Visualization of Selected Building in BIM Environment**

The building as case study must be evaluated according to its components and materials' quantities carries great importance for achieving correct calculations. The selected BIM program used for visualizing the Office Building is Autodesk Revit. The reason for selecting Revit as a BIM program is One Click LCA is working with near to zero problem and the working environment is more convenient for the selected case. The program is set to architectural template with metric system and the selected unit

is centimeters. Plans are being imported by pdf versions and rescaled according to the true dimensions. Heights, widths, and lengths are set according to the drawings that are obtained from project management department of EMU. The selected building components which are columns, beams, slabs, and foundations are drawn according to the obtained drawings (Figure 22).

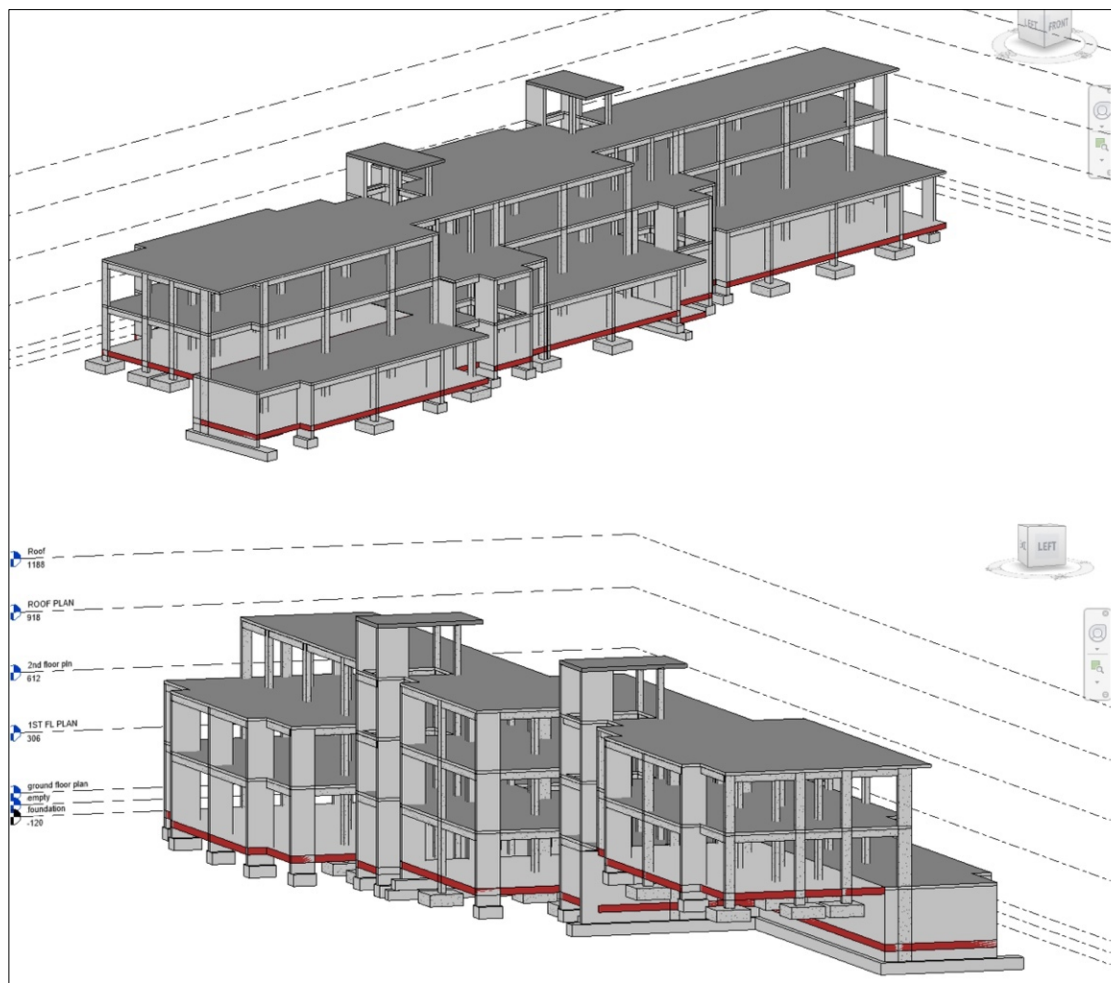

Figure 22: EMU, Faculty of Architecture 'Office Building' Visualization by Autodesk Revit (Drawn by author, 2023)

The Office Building's selected foundation type is pad foundation. The building is constructed on a slopy site, and the topography solved with retaining walls and pad foundation according to the constructed time technology which is 1997. Buildings general layout can be explained with two cores where the vertical circulations are

located and three parts enveloping the cores on the sides with different functional units such as offices, seminar rooms and service units. The walls are constructed as 25cm and column dimensions are varied according to the statistical calculations made by engineers which are 25x50cm, 25x60cm, and 25x80cm as sheer walls around the shafts in the vertical circulation cores.

Two-way beam used as beam system and the depth of beam is 35 cm, 50cm in total with 15cm floor depth. The floor thicknesses are 15 cm with concrete slab, sand fill, mortar, and tiles as finishing. There is no basement floor the office building therefore the slab above the foundation system is applied as compacted soil, 15cm of hardcore, 10cm of blinding concrete, sand fill mortar and tiles as finishing.

The roof system is not applied for this study due to the materials are not appropriate to be evaluated as reusability or recyclability potential. The walls are also not included for not having any mistaken during the evaluation period.

### **3.2.2 Integration of Autodesk Revit and One Click LCA**

One Click LCA program has a combination of add-on and cloud base calculation system. As a first step, the program requires a username and password that obtained from company itself. The system lets the user for many trials by entering the given password each time for a new project.

Autodesk Revit also requires the username and password entrance for One Click LCA add-in for material selection (Figure 23).

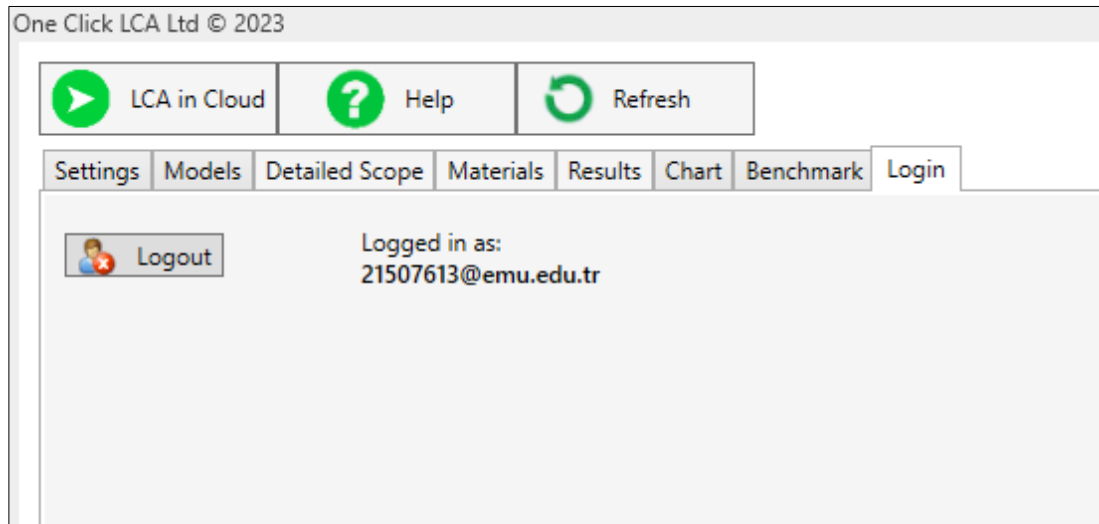

Figure 23: Logging in process for One Click LCA add-in in Autodesk Revit (Graphic by author, 2023)

The next step is to check and correct the settings for the project to be evaluated. The database that One Click LCA is going to be using is chosen as European and global data (CML). It was recommended for the countries that are not included in Europe. The scope of model is building and the default material grouping mode according to the Autodesk Revit's working environment is split family types into materials for detailed models. The unit is selected as metric (Figure 24).

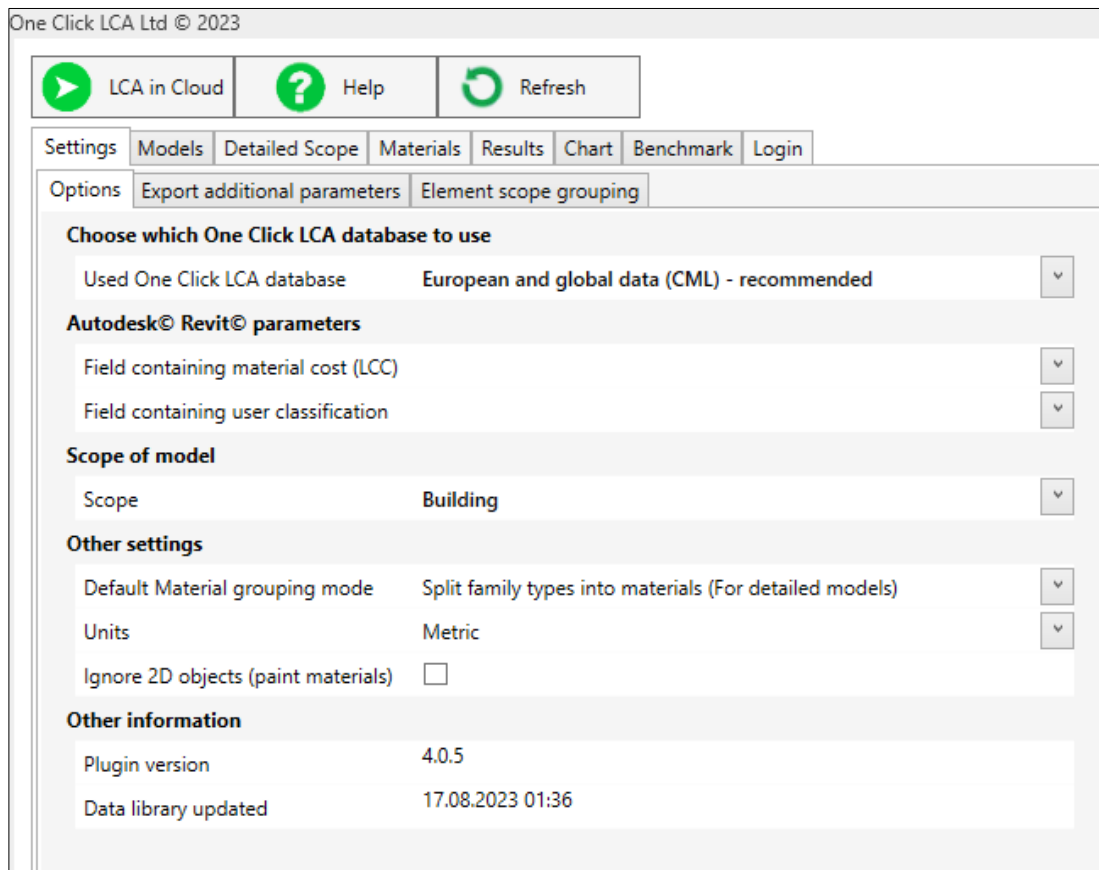

Figure 24: Arrangement of settings for One Click LCA add-in in Autodesk Revit (Graphic by author, 2023)

The selection of model, worksets, design options and phases is important for defining the scope of assessment. If the model that is drawn in Autodesk Revit has linked models, the selection for this phase should be 'Detailed Configuration'. Active view should be selected if the requirement for the study is exporting all elements in active Autodesk Revit view. If the study requires selection of some parts, then the selected elements in the model should be selected. This study required more information for the assessment therefore the 'detailed configuration' is selected (Figure 25).

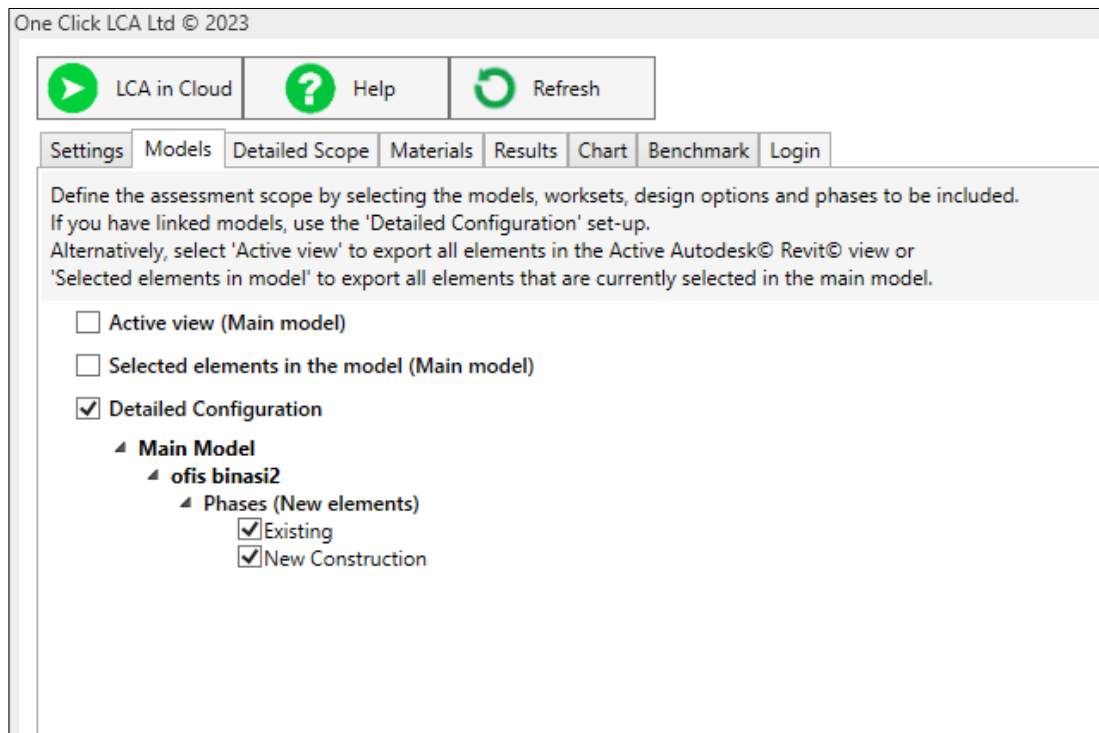

Figure 25: Selecting the scope of assessment as selecting model for One Click LCA add-in in Autodesk Revit (Graphic by author, 2023)

The next step, which is detailed scope, is an optional stage. This part is enabling to change default settings such as categories, families, and family types. For this phase, the important and changeable part was the categories. Each category that are drawn in the project has a specific unit as default in the Autodesk Revit system. This part gives opportunity to change the units for each category. This study required information in the level of; floors as area, structural columns, foundations, structural framing, and walls (retaining walls) as volume (Figure 26).

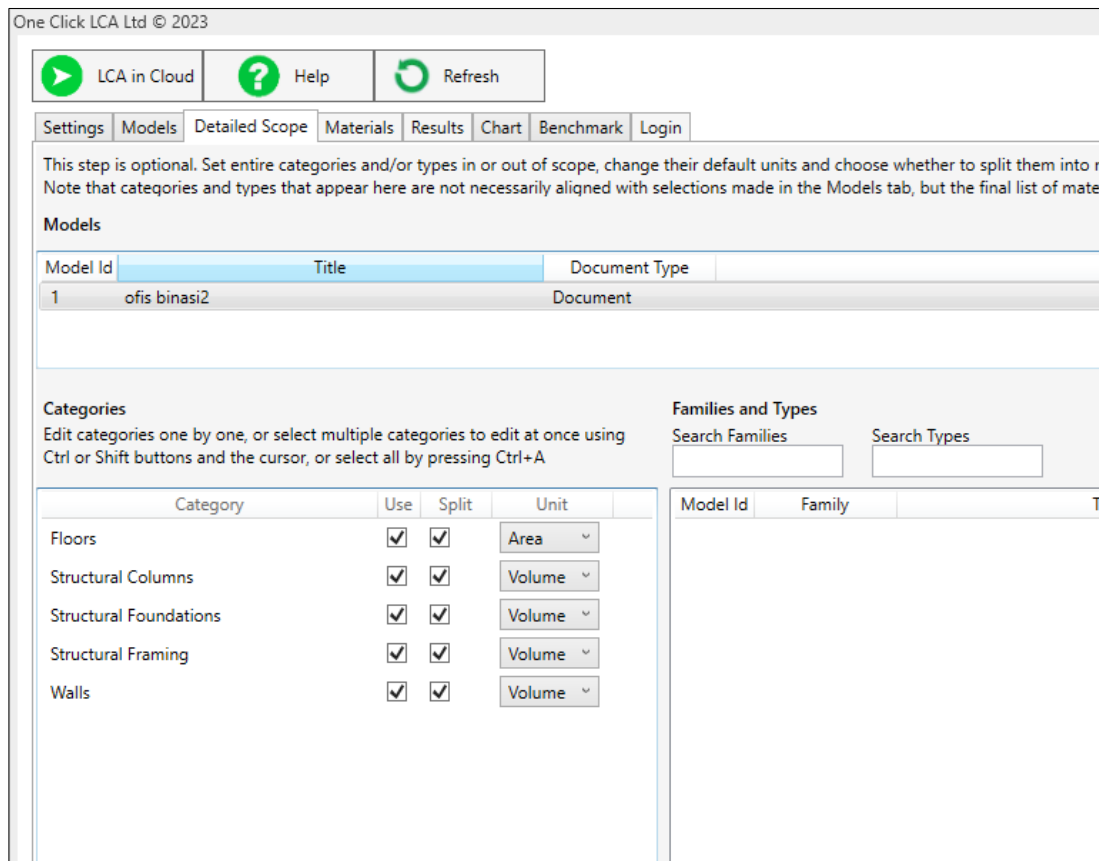

Figure 26: Selecting the detailed scope for One Click LCA add-in in Autodesk Revit (Graphic by author, 2023)

Selection of the materials is the most complicated and time consuming part of all stage. It should be noted that, all the materials are selected according to the data that has been gathered from the EMU project management department. For the case of Cyprus, it is difficult to find the exact materials in the database of both Autodesk Revit and One Click LCA therefore, the materials are selected as the closest to the ones in real life. The reason for this is the database that both Autodesk Revit and One Click LCA provides is a massive information in the range of worldwide. Therefore, finding and selecting the materials to be found was challenging.

The system has divided the categories into families that are used in the Revit to draw the project. The floors are divided into different segments to be selected individually.

The slab that is above the foundation is selected as ready-mix concrete as C25/30, in the unit of area. The intermediate floors are selected as concrete cast-in-situ floor slab assembly, 150mm depth with 30/37 for south Europe in the unit as area. The Revit program is organizing the floors selection according to the specifications in its own family templates. Therefore, there are many other materials can be seen in the materials lists even though they are not in the scope of this thesis.

The retaining wall element which is placed on the ground floor for the level differences. The selection of retaining wall as a material in one click platform is a C30/37 concrete wall element, a basic selection. The thickness for the retaining wall is 25cm.

There is one type of structural columns that has the dimensions of 25cm by 50cm. The material type for this column type is concrete, cast-in-place and the unit is set to volume to be calculated in m<sup>3</sup>. The LCA material mapping for this column type is C32/40.

The structural foundation selection is pad foundation according to the technical drawings of Office Building. The selection of material for pad foundation is made with the database in the system. For Office Building, it is drawn as 15cm foundation slab with 90x30x60cm of bearing footing. The material that is selected for this pad foundation is a ready-mix concrete for shallow foundations which has C25/30 concrete.

Finally, the last component of the Office Building is beams. The beams are selected as two-way beam system for the concrete frame construction system. According to the

span requirements the beam thickness is 35cm with 15cm slab thickness. The selection of material for the beam type is cast-in-place and concrete. Ready-mix concrete for exterior beam with C25/30 is found from the database of One Click LCA (Table 1).

Table 1: Material selection and mapping in the study.

#	Categories	Family Type in Autodesk Revit	One Click LCA Material Mapping	Unit	Quantity (m3) in Total
1	Columns	Concrete Rectangular 25 x 50cm/25 x 70cm/ 30 x 30cm	Concrete column, Reinforced, C32/40	Volume	78,86 m3
2	Beams	25 x 70 cm Concrete – Cast-in-place - Rectangular Beam	Ready-mix concrete for exterior beam, C25/30 XC3/XC4 CEM II/A	Volume	108,33 m3
3	Floors	Concrete-commercial 15cm/20cm/37cm	Ready-mix concrete for slabs, C25/30 XC1/XC2 CEM II/A	Area	3348,31 m2
4	Retaining Walls	Retaining- 25cm Concrete	Concrete Wall Element, C30/37 – C50/60	Volume	108,23 m3
5	Structural Foundations	Bearing Footing Foundation	Ready-mix concrete for shallow foundations, C25/30 XC2, CEM II/A	Volume	144,87 m3

For further information detailing, there are few more steps to be completed. The other phase is selecting the benchmark parameters. Cyprus is selected as the Country and building type is defined as the Office Building. Gross area of the project is 2726,60m<sup>2</sup> and the benchmark to be obtained is selected as CH Q1 2019 Global for Office. There are many selections in the embodied carbon benchmark option according to the countries policies or the green building rating system requirements. For this study, it was important to go with a global selection specified with an office building since

there are no further studies that is done in the Cyprus island for reusability or recyclability of construction materials (Figure 27).

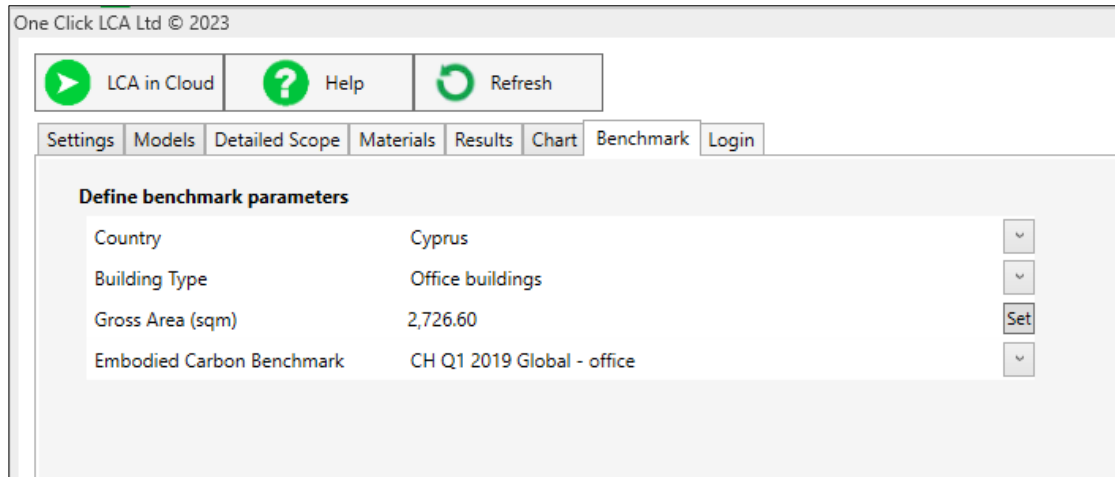

Figure 27: Defining benchmark parameters for One Click LCA add-in in Autodesk Revit (Graphic by author, 2023)

### 3.2.3 Characterization of Office Building for Building Circularity Tool

The next phase is creating the new project in the One Click LCA Cloud environment after completing all processes in the Autodesk Revit with One Click LCA add-in. Clicking the button entitled 'LCA in Cloud', will lead the user directly to the One Click LCA webpage. The first phase in the webpage is the create a project for evaluation process. It directly transfers some of the selections that are already made in the Autodesk Revit program, One Click section. After the connection is created, it skips the data section as it is shown in the figure 32, where the user already saved it in the Revit program. The webpage requires settings to be set for the new design. Choosing the project as EMU office building for circularity calculation is given as a project name. For this study it is chosen as the new design, and the tool as building circularity and Level(s) life-cycle assessment. In order to filter the settings, building without building technology is selected for the project. Removing empty data and converting all the metric unit system should be selected as well (Figure 28).

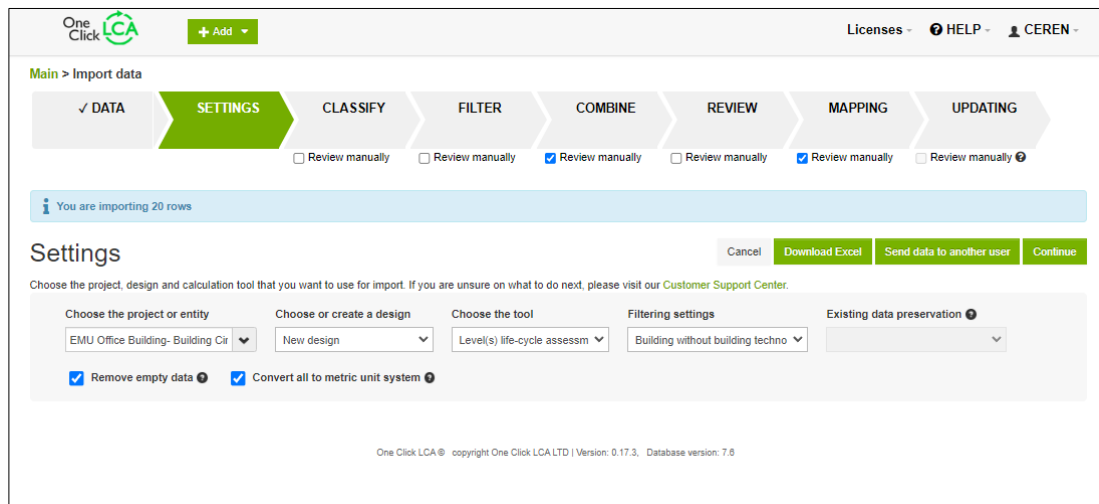

Figure 28: Arranging the settings for One Click LCA Cloud, One Click LCA webpage (Graphic by author, 2023)

Creating the new design is another important aspect for starting evaluation. The pop-up window is requiring the related information. The name should be given in detailed with the scope of the project. The stage of the construction project should be selected correctly. The stages are created according to the RIBA/AIA stages. For this study, there are only components of the building drawn, therefore it is selected as X – Component only (not the whole building). The tools that is going to be used in this design should be checked accordingly. In this study, both Level(s) life-cycle assessment (EN15804 +A1) and Building Circularity is checked. For the scope of the study, and type of the analysis part, Levels EU is pre-defined since the tool is checked earlier. Project type is selected as Component evaluation only, and the frame type is defined as concrete frame (Figure 29).

**Create a design**

**Name, design stage and calculation tools**

Name

office bldg - new - bldg circularity

Additional information (e.g. description in portfolio)

Stage of construction process (RIBA / AIA stages)

X - Component only (not whole building)

Choose the tools you want to use in this design

- Level(s) life-cycle assessment (EN15804 +A1)
- Building Circularity

**Scope and type of analysis**

Pre-defined scopes (if available)

Levels EU

Project type

Component evaluations only

Frame type

Concrete frame

Included parts. Check all applicable.

- Foundations and substructure
- Structure and enclosure
- Finishings and other materials
- External areas
- Services

Cancel **Add**

Figure 29: Creating a New Design for One Click LCA Cloud, One Click LCA webpage (Graphic by author, 2023)

Some of the parts in the above part, from settings to mapping, is being filled from the information that is already set in Autodesk Revit. In Mappings section, there is a list that has been already selected in the previous stages, Revit-One Click plug in section-materials subsection. The database in here is showing more information and giving an opportunity for changing the material once more with a wider range of material selection (Figure 30).

Main > EMU Office Building -> office bldg - new - bldg circularity > Import data

✓ DATA    ✓ SETTINGS DATAPOINTS: 20    ✓ CLASSIFY    ✓ FILTER DATAPOINTS: 19    ✓ COMBINE DATAPOINTS: 19    ✓ REVIEW DATAPOINTS: 19    **MAPPING DATAPOINTS: 19 + 0**    UPDATING

MAPPING    Results    Cancel    Download Excel    Save new mappings    Continue

Material: Filter...    Country: Filter...    Data source: Filter...    Type: Filter...    Upstream: Filter...    CO2e: Filter...    Unit: Filter...    Properties: Filter...    Clear

?  
 Datasets are automatically identified by the software if similar data was mapped previously. Existing mappings are used in a descending order of priority: your own mappings, mappings of your organisation, mappings in same country, and all mappings (to add system mappings, full name, and recognition rulesets AND defaults from splitting data). Mappings take into consideration also other properties of the imported dataset, for example its classification. You can change any mappings you wish. Changes will be automatically memorized.  
 Unidentified, unquantified or composite materials are not imported, unless you map them to resources. Units will be converted automatically if necessary.

✓ Identified data: 19 / 100 % of volume

Material	Class	Comment	Building Parts	Quantity	Share	Resource name	Mapping basis	Decide later	Save new mappings
concrete, cast in situ	SLAB	Floor	1.2.1 Frame (bea	2248 m2	19.22 %	Ready-mix concrete, normal-stren	Global users	<input type="checkbox"/>	Delete
concrete, cast in situ	SLAB	Floor	1.2.1 Frame (beams, columns and	1061 m2	16.15 %	Ready-mix concrete for indoor flo	Mapped in model	<input type="checkbox"/>	Delete
site - hardcore	SLAB	Floor	1.2.1 Frame (beams, columns and	1061 m2	15.61 %	Ready-mix concrete for indoor flo	Mapped in model	<input type="checkbox"/>	Delete
concrete, sand/cement screed	SLAB	Floor	1.2.1 Frame (beams, columns and	2248 m2	9.61 %	Floor screed mortar, cement scre	Global users	<input type="checkbox"/>	Delete
concrete, cast-in-place gray	BECAM	Concrete Rectangular Beam	1.2.1 Frame (beams, columns and	106 m3	9.26 %	Ready-mix concrete for exterior bi	Mapped in model	<input type="checkbox"/>	Delete
concrete, cast in situ	EXTERNAL	Basic Wall	1.2.3 External walls	106 m3	9.25 %	Concrete wall element, C30/37 - C	Mapped in model	<input type="checkbox"/>	Delete
concrete, cast-in-place gray	FOUNDATI...	Footing Rectangular	1.1.1 Piles	97 m3	8.31 %	Ready-mix concrete for shallow fo	Mapped in model	<input type="checkbox"/>	Delete
concrete - cast-in-place concrete	COLUMN	Concrete Rectangular	1.2.1 Frame (beams, columns and	57 m3	4.88 %	Concrete column, precast, reinfor	Mapped in model	<input type="checkbox"/>	Delete
concrete, cast in situ	FOUNDATI...	Wall Foundation	1.1.1 Piles	37 m3	3.12 %	Ready-mix concrete for shallow fo	Mapped in model	<input type="checkbox"/>	Delete
concrete - cast-in-place concrete	COLUMN	Concrete Rectangular	1.2.1 Frame (beams, columns and	14 m3	1.16 %	Concrete column, precast, reinfor	Mapped in model	<input type="checkbox"/>	Delete
sand	SLAB	Floor	1.2.1 Frame (beams, columns and	1061 m2	1.09 %	Ready-mix concrete for indoor flo	Mapped in model	<input type="checkbox"/>	Delete
concrete, cast in situ	FOUNDATI...	Foundation Slab	1.1.1 Piles	11 m3	0.95 %	Ready-mix concrete for shallow fo	Mapped in model	<input type="checkbox"/>	Delete
concrete - cast-in-place concrete	COLUMN	Concrete Rectangular	1.2.1 Frame (beams, columns and	8.22 m3	0.7 %	Concrete column, precast, reinfor	Mapped in model	<input type="checkbox"/>	Delete
structure, steel bar joist layer	SLAB	Floor	1.2.1 Frame (beams, columns and	39 m2	0.25 %	Ready-mix concrete for slabs, C21	Mapped in model	<input type="checkbox"/>	Delete
concrete masonry units	SLAB	Floor	1.2.1 Frame (beams, columns and	39 m2	0.25 %	Ready-mix concrete for slabs, C21	Mapped in model	<input type="checkbox"/>	Delete
concrete, sand/cement screed	SLAB	Floor	1.2.1 Frame (beams, columns and	39 m2	0.17 %	Ready-mix concrete for slabs, C21	Mapped in model	<input type="checkbox"/>	Delete
gross internal floor area	OTHER		Not defined	1 m2		Gross Internal Floor Area (PIMS)	Users in Cyprus	<input type="checkbox"/>	Delete
damp proofing	SLAB	Floor	1.2.1 Frame (beams, columns and	2248 m2		Concrete cast in situ floor slab as	Mapped in model	<input type="checkbox"/>	Delete
damp proofing	SLAB	Floor	1.2.1 Frame (beams, columns and	1061 m2		Ready-mix concrete for indoor flo	Mapped in model	<input type="checkbox"/>	Delete

Figure 30: Creating a New Design for One Click LCA Cloud, One Click LCA webpage (Graphic by author, 2023)

After this stage it is validating the information that is given and finalizing the evaluation. There are other subsections for entering more data to be able to get more accurate calculations and results.

From the section of input data, many missing information can be added to be calculated. Building materials, energy consumption annually, water consumption annually, construction site operations, calculation period, emissions and removals, and building area can be filled according to the results to get. For this study, the building materials are already set and checked in both programs, energy consumption is set to 200.000 KWh annually, according to the verification of project management department of EMU. The water consumption cannot be calculated due to the school

base central working system. Building area definitions can be checked here again and many other information can be added according to the needs. Gross internal floor area is defined as 2726,6m<sup>2</sup>. User days is set to 260 annually, as in working days in specific office building. Approximately 2880 hours for working hour is selected. The number of users is set to 100 people according to the stuff numbers obtained from the webpage of architecture department, interior architecture department and the faculty of architecture (Figure 31).

### 1. Area definitions

**Building area (mandatory)** ↔ Compare answers -

Please always provide gross internal floor area to get benchmark feedback. These figures are always given excluding parkings and motor may mark further detail on the basis of the area definition in the comments and provide additional national area definitions. Using additional benchmarking.

Start typing or click the arrow ▼

Resource ⇅	Quantity ⇅	Comment ⇅	
Gross Internal Floor Area (IPMS/RIC ?)	2726,6 m <sup>2</sup>		change ▾
User days ?	260	annual days	change ▾
User hours ?	2880	annual hours	change ▾
Number of users ?	100	nearly	change ▾

Figure 31: Area and user definition for One Click LCA Cloud, One Click LCA webpage (Graphic by author, 2023)

The building circularity tool is working with the same interface. The calculation of LCA requires main basic data for assessing the building circularity which is mainly gathered with the help of Autodesk Revit integration. The circularity of materials is being selected individually to be calculated. And the system given possibility to choose the end of life processes for each material and gives the results accordingly. All end of life scenarios for each material is selected and results are saved in order to understand

the materials reusability and recyclability potential. Each material and the components have different scenarios which will be demonstrated in the following sections.

## **Chapter 4**

### **RESULTS AND DISCUSSION**

#### **4.1 Building Circularity Results of The Office Building**

The method for this study explained in the previous chapter. The study conducted according to different end of life scenarios as demonstrated. The following subsections shows the results and the explanations for the reinforced concrete material circularity results for the Faculty of Architecture Office Building of EMU. First it will give the results of selecting end of life defined in the environmental product declaration, next it will show the results of crushing concrete material into aggregate, later it will explain the results of reusing the materials, lastly it will show the results for crushing into aggregate or landfilling option.

##### **4.1.1 Building Circularity Data Optimization for EPD Definition**

The building circularity report gives various data related to the selected materials end of life scenario. There is a holistic EoL index that is being prepared for achieving results related with recyclability and reusability of materials in environmental product declaration (EPD). There are backgrounds for every product to be used in the system and different EoL phases which provides a cradle-to-grave impact. OneClick LCA demonstrated that the database they are using is included EPDs globally available. The selections is done to achieve the results for “Use EOL defined in EPD” for the available materials for this study.

Table 2: Data Optimization for Using EoL Defined in EPD

#	Categories	Quantity (m3) in Total	Unit	Service Life	EOL Process
1	Columns	78,86 m3	Volume	As Building	Use EOL defined in EPD
2	Beams	108,33 m3	Volume	As Building	Use EOL defined in EPD
3	Floors	3348,31 m2	Area	As Building	Do Nothing
4	Retaining Walls	108,23 m3	Volume	As Building	Use EOL defined in EPD
5	Structural Foundations	144,87 m3	Volume	Permanent	Use EOL defined in EPD

It is demonstrated that the table 2 is explaining the selections made in material selection and end of life treatment for building circularity analysis. The columns, beams, retaining walls, and structural foundations have been selected as EOL as in EPD. Only floors were selected as do nothing due to its material specification determined by the OneClick LCA database. The building circularity results came as it is shown in figure 32.

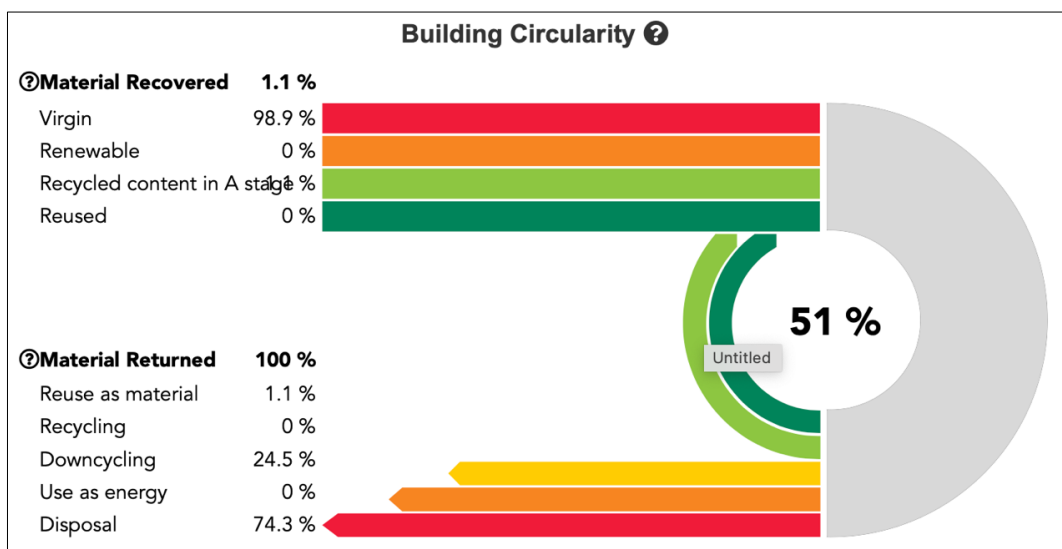

Figure 32: Building Circularity Results for EOL defined in EPD Option (Obtained from OneClickLCA, 2023)

The recovered materials represent the use of materials in the project while returned materials represents how effectively materials are returned instead of downgrading or disposing. Accordingly, the selection of this end of life scenario gave results which can be seen in table 3.

Table 3: Building Circularity Report of Returned Material for Using EoL Defined in EPD

<b>Materials Returned</b>							
<b>#</b>	<b>Categories</b>	<b>Quantity (m<sup>3</sup>) in Total</b>	<b>Unit</b>	<b>% in Total</b>	<b>Disposal %</b>	<b>Material Returned %</b>	<b>Circularity%</b>
1	Columns	78,86 m <sup>3</sup>	Volume	6,4%	10,24%	6,24%	6,23%
2	Beams	108,33 m <sup>3</sup>	Volume	10%	5%	10%	10,3 %
3	Floors	3348,31 m <sup>2</sup>	Area	65,66%	57,89 %	65,66 %	65,7 %
4	Retaining Walls	108,23 m <sup>3</sup>	Volume	7,7 %	10,24%	7,77 %	7,75 %
5	Structural Foundations	144,87 m <sup>3</sup>	Volume	10,34 %	13,64%	10,34 %	10,32 %

The table 3 shows that materials that are returned for vertical structures in total for this study is 6,4%, 6,23% circularity calculation for the reinforced concrete material. The beams and floors have the majority volume of concrete, and the circularity report gives 76% circularity in terms of returned material. The reinforced concrete in foundation calculated as 10,32% with 10,34% material return possibility.

Table 4: Building Circularity Report of Recovered Material for Using EoL Defined in EPD

Materials Recovered						
#	Categories	Quantity (m3) in Total	Unit	Reuse as Material tons	Downcycling tons	Disposal tons
1	Columns	78,86 m3	Volume	-	-	7,71%
2	Beams	108,33 m3	Volume	11,68%	9,83%	13,79%
3	Floors	3348,31 m2	Area	88,32%	82,78%	59,9%
4	Retaining Walls	108,23 m3	Volume	-	-	9,6%
5	Structural Foundations	144,87 m3	Volume	-	-	12,79%

The table 4 demonstrates the results for recovered materials for the study by the choose of end of life defined in environmental product declaration. Accordingly, the material of reinforced concrete for floors can be used with downcycling option which has the most concrete material in terms of volume with 82,78%. According to the table 4, it can be said that the disposal selection as percentages for columns, beams, retaining walls and structural foundation are in minority with below 20%. As a result, the 85,71% of reinforced concrete horizontal structures demonstrated as possible for recyclability potential according to the Building Circularity Report for this study.

Additionally, the steel bars are being calculated by the integration of Autodesk Revit and OneClickLCA programs, and the calculations gave recyclability reports for steel bars which came as 100% of both reusability and recyclability potential, therefore the circularity result came as 100%.

#### 4.1.2 Building Circularity Data Optimization for Crushing Concrete into Aggregate

The optimization for the study that is conducted is set for component to crushing the reinforced concrete material to aggregates. This selection is not available for some of the materials according to their usage and quality of concrete. Considering the age of the building and technology of time, the building's reinforced concrete selection was not matching the currently used concrete. The system of OneClickLCA works accurately for the countries in Europe which is well-defined in terms of database. The table 5 shows the data optimization for crushed into aggregate for each material down below.

Table 5: Data Optimization for Using Crushing Concrete into Aggregate

#	Categories	Quantity (m3) in Total	Unit	Service Life	EOL Process
1	Columns	78,86 m3	Volume	As Building	Concrete crushed to aggregate (for sub-base layers)
2	Beams	108,33 m3	Volume	As Building	Rebar separated (2%)
3	Floors	3348,31 m2	Area	As Building	Concrete crushed to aggregate (for sub-base layers)
4	Retaining Walls	108,23 m3	Volume	As Building	Rebar separated (2%)
5	Structural Foundations	144,87 m3	Volume	Permanent	Concrete crushed to aggregate (for sub-base layers)

As it is shown in the table 5, columns, floors, and structural foundations are calculated according to the concrete material to be crushed into aggregate for the sub base layers. The beams and the retaining walls for this calculation was selected as rebar separated by 2% since there were no selection option for crushing concrete into aggregate

according to the quality of the concrete. The results for building circularity for the office building came 26% in total (Figure 33).

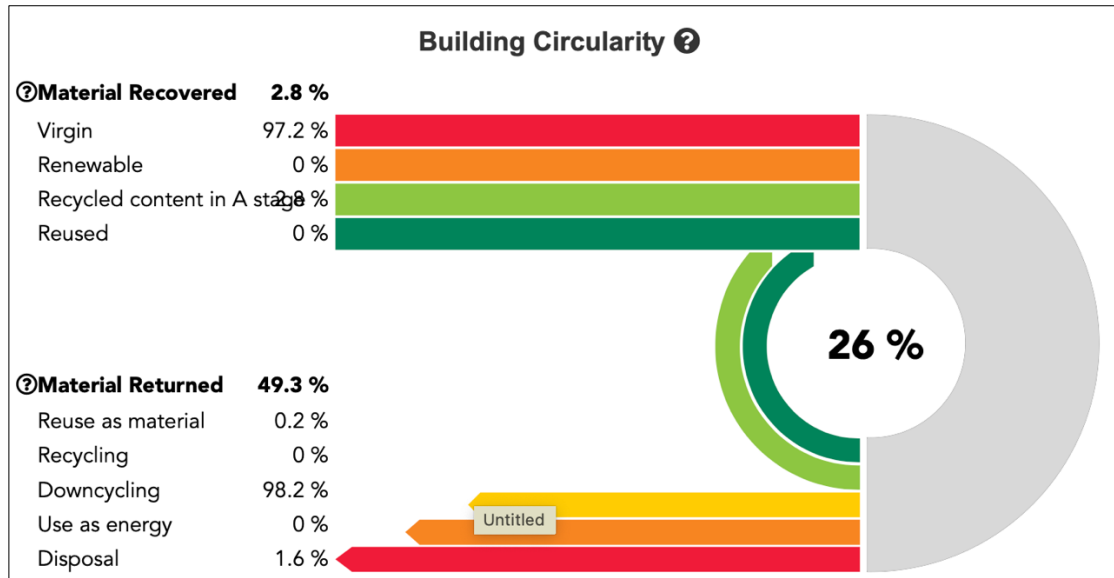

Figure 33: Building Circularity Results for Reinforced Concrete Crushed into Aggregate Option (Obtained from OneClickLCA, 2023)

Accordingly, the table 6 shows the results for materials returned for this study. The results for columns are showing the virgin tons that are returned as material in 5,77% while 12,02% can be recycled as material. The beams and retaining walls are not in majority in terms of reinforced concrete volume, and the result for recycling of the material did not go into calculation. Floors are in majority for its volume of concrete material, and the result for recyclability for the reinforced concrete is 49,57%. According to the results, the structural foundation came as 38,41% for recycled content. The returned materials in this table for crushed into aggregate and also it gave the rebar separated with 2% solutions.

Table 6: Building Circularity Report of Returned Material for Concrete Crushed into Aggregate

<b>Materials Returned</b>						
<b>#</b>	<b>Categories</b>	<b>Quantity (m<sup>3</sup>) in Total</b>	<b>Unit</b>	<b>Total Tons</b>	<b>Virgin Tons</b>	<b>Recycled Content Tons</b>
1	Columns	78,86 m <sup>3</sup>	Volume	5,95%	5,77 %	12,02%
2	Beams	108,33 m <sup>3</sup>	Volume	1,3 %	1,34 %	-
3	Floors	3348,31 m <sup>2</sup>	Area	75,35%	76,1%	49,57%
4	Retaining Walls	108,23 m <sup>3</sup>	Volume	1,32%	1,41 %	-
5	Structural Foundations	144,87 m <sup>3</sup>	Volume	17,4%	16,78 %	38,41%

The other results for the building circularity is materials recovered in the building and the results are given in the table 7. According to the table, only floors are crushed into concrete and with 100% possible usage in total for the whole components that are evaluated in this study. However, the downcycling option for all components are calculated as it shown in the table. The floors for concrete crushed into aggregate joint to the circularity with 75,09% and vertical structural elements followed it with nearly 50% of downcycling option.

Table 7: Building Circularity Report of Recovered Material for Concrete Crushed into Aggregate

Materials Recovered						
#	Categories	Quantity (m3) in Total	Unit	Reuse as Material tons	Downcycling tons	Disposal tons
1	Columns	78,86 m3	Volume	-	41,24%	-
2	Beams	108,33 m3	Volume	-	1,32%	-
3	Floors	3348,31 m2	Area	100%	75,09%	100%
4	Retaining Walls	108,23 m3	Volume	-	6,01%	-
5	Structural Foundations	144,87 m3	Volume	-	17,58%	-

The tables show the circularity option for crushed the reinforced concrete into aggregate is related with the steel bars percentages in it. The steel bars have again 100% reusability and recyclability potential for the building.

As a result, nearly 50% of the reinforced concrete calculated as recovered materials for both floors and foundations. The downcycling option for all components of the building which are included in this study is calculated to be used as an energy source with average percentages. The material returned results came the highest for the floor components with nearly 75%.

#### 4.1.3 Building Circularity Data Optimization for Reuse as Material

In this section, the data for materials used in this study for circularity of the building is organized for reuse as material. The reuse as material selection is not available for all components. Table 8 demonstrate that, the components used in the study and the selection as end of life phase.

Table 8: Data Optimization for Using Reuse as Material Option

#	Categories	Quantity (m3) in Total	Unit	Service Life	EOL Process
1	Columns	78,86 m3	Volume	As Building	Reuse as Material
2	Beams	108,33 m3	Volume	As Building	Reuse as Material
3	Floors	3348,31 m2	Area	As Building	Concrete crushed to aggregate (for sub-base layers)
4	Retaining Walls	108,23 m3	Volume	As Building	Reuse as Material
5	Structural Foundations	144,87 m3	Volume	Permanent	Concrete crushed to aggregate (for sub-base layers)

As it is seen in the table 8, in this phase of the study, only the retaining walls, columns, and beams have been able to be selected as reuse as material for the future usage possibility. The reason for not been able selecting for all components to be reused as material is the concrete type of the building which was used for structural foundation and the floors. The results for the reused as material option for the study may be seen in figure 34. The result for building circularity out of the selection for reuse as material for the reinforced concrete is 28%.

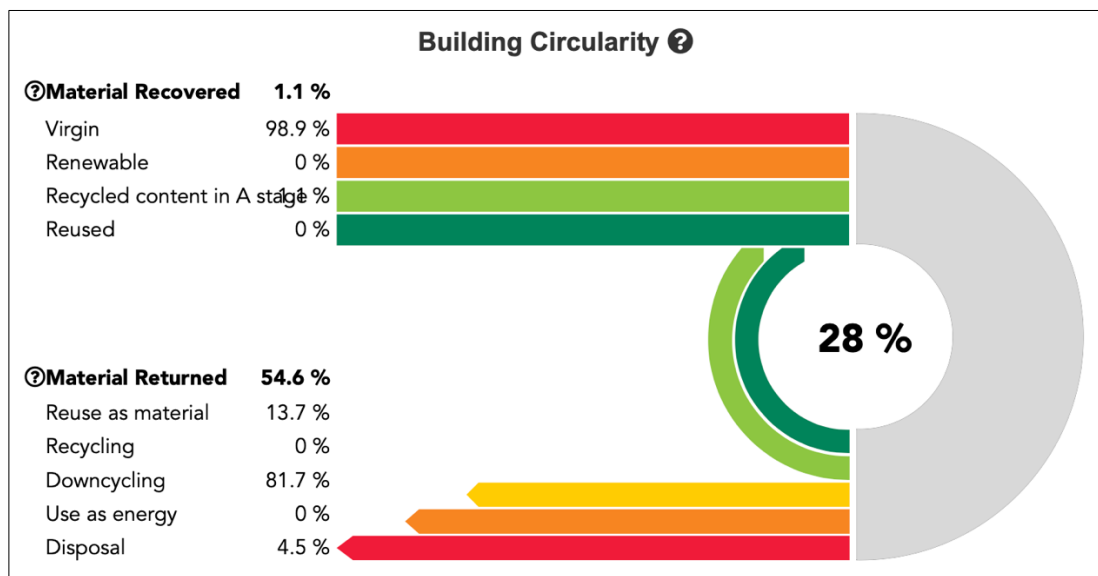

Figure 34: Building Circularity Results for Reuse as Material Option (Obtained from OneClickLCA, 2023)

The table 9 shows the results for material returned for the selection of reused as material of reinforced concrete. Accordingly, the floor components for reinforced concrete results occurred as 100% recyclability potential while any other component has no value.

Table 9: Building Circularity Report of Returned Material for Reuse as Material Option

Materials Returned						
#	Categories	Quantity (m <sup>3</sup> ) in Total	Unit	Total Tons	Virgin Tons	Recycled Content Tons
1	Columns	78,86 m <sup>3</sup>	Volume	5,77%	5,83%	-
2	Beams	108,33 m <sup>3</sup>	Volume	1,3 %	1,34 %	-
3	Floors	3348,31 m <sup>2</sup>	Area	77,49%	77,25%	100%
4	Retaining Walls	108,23 m <sup>3</sup>	Volume	7,18%	7,26 %	-
5	Structural Foundations	144,87 m <sup>3</sup>	Volume	9,56%	9,66 %	-

The table 10, on the other hand, shows the materials recovered for the reuse as material selection. The result for downcycling for beams is 10%, and for floors it is 88,17% with the high amount of volume and low quality of reinforced concrete material. The reuse as material for columns is 40,84%, and for the retaining walls it is 50,86%. This means that the steel bars inside the reinforcement is separately calculated and the result is again 100% of reusability for the steel material. Structural foundation and the reinforced concrete material for it has 11,83% value for downcycling and usage possibility which means degraded materials can be achieved to be used not for new construction purposes.

Table 10: Building Circularity Report of Recovered Material for Reuse as Material Option

<b>Materials Recovered</b>						
<b>#</b>	<b>Categories</b>	<b>Quantity (m3) in Total</b>	<b>Unit</b>	<b>Reuse as Material tons</b>	<b>Downcycling tons</b>	<b>Disposal tons</b>
1	Columns	78,86 m3	Volume	40,84%	-	-
2	Beams	108,33 m3	Volume	-	10,11%	-
3	Floors	3348,31 m2	Area	8,31%	88,17%	100%
4	Retaining Walls	108,23 m3	Volume	50,86%	-	-
5	Structural Foundations	144,87 m3	Volume	-	11,83%	-

As a result, the materials that are selected as reused as material gives opportunity the most for circularity of the building. The foundation of the building has 12% of downcycling and reuse as material. The beams are also calculated as 32%, and floors as 90% of reusable possibility with downcycling. The recycling possibility as reusable material is calculated as retaining walls with 55%, and for columns with 45%. The

returned materials are mainly for floors with 67% and horizontal structural elements such as beams with 31%, and for foundation it is calculated as 12%. Overall, the circularity of the selected building's results shows that, the foundation has 9%, the retaining walls has 13%, while columns has 11%, and the vertical elements such as beams and floors has the 67% in total. The steel bars are calculated in this section as well 100% of reusability potential and included to the building circularity report and final result.

#### 4.1.4 Building Circularity Data Optimization for Landfilling for Concrete

The last part of the study is setting the parameters for all components to be evaluated as landfill option with crushing into aggregate integration. This selection is the least wanted option in terms of sustainability and building circularity. The landfilling may be accepted as one of the biggest harms that is being done by the construction sector. Accordingly, not all the components are being accepted in the parameters for landfill due to the hazardous effects and/or quality of the concrete used in building. The table 11 shows the selections for each component and material to be calculated for building circularity.

Table 11: Data Optimization for Using Crushing Concrete to Aggregate or/and Landfill Option

#	Categories	Quantity (m3) in Total	Unit	Service Life	EOL Process
1	Columns	78,86 m3	Volume	As Building	Landfilling for Concrete
2	Beams	108,33 m3	Volume	As Building	Landfilling for Concrete
3	Floors	3348,31 m2	Area	As Building	Landfilling for Concrete
4	Retaining Walls	108,23 m3	Volume	As Building	Rebar Separated (2%)
5	Structural Foundations	144,87 m3	Volume	Permanent	Landfilling for Concrete

The suggested EoL Process for almost all components in the studied building is landfilling for concrete option except retaining walls which is rebar separated with 2% of a value. Relatively results came as 51% of building circularity (Figure 35).

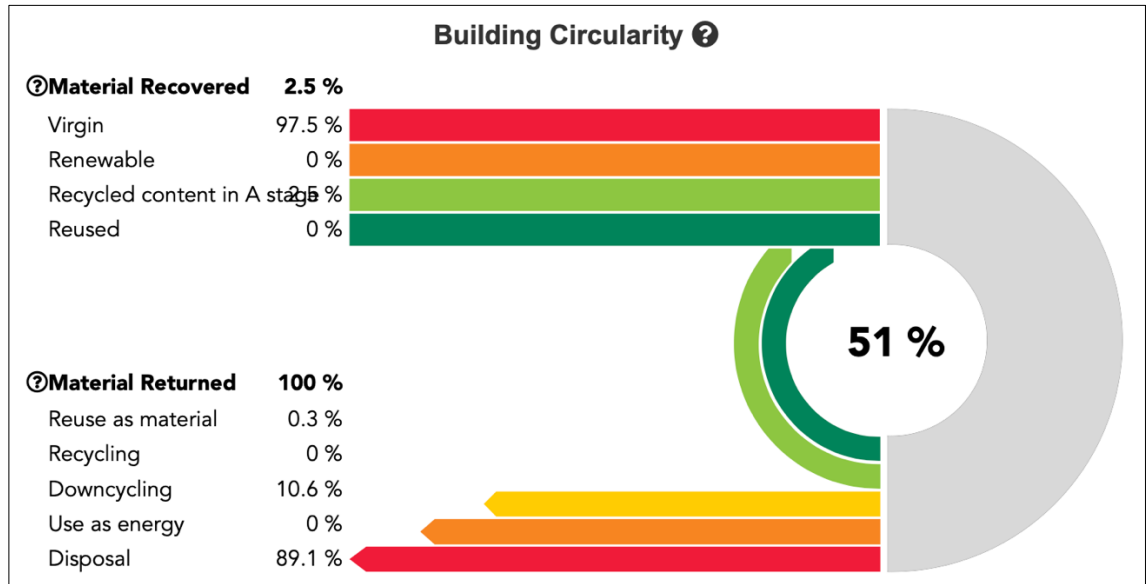

Figure 35: Building Circularity Results for Refilling for Concrete Option (Obtained from OneClickLCA, 2023)

The results for building circularity of the selection of landfilling for concrete is explained for material returned in table 12. The Recycled content for returned materials of this study is 11,27% for columns, 52,72% for floors, and 36,01% for foundations in total. There are no values for beams and retaining walls as recycled content due to the selection of separation the steel bars to be used for further purposes.

Table 12: Building Circularity Report of Returned Material for Landfilling for Concrete Option

<b>Materials Returned</b>						
<b>#</b>	<b>Categories</b>	<b>Quantity (m<sup>3</sup>) in Total</b>	<b>Unit</b>	<b>Total Tons</b>	<b>Virgin Tons</b>	<b>Recycled Content Tons</b>
1	Columns	78,86 m <sup>3</sup>	Volume	5,76%	5,62%	11,27%
2	Beams	108,33 m <sup>3</sup>	Volume	2,86%	2,91%	-
3	Floors	3348,31 m <sup>2</sup>	Area	76,25	76,81%	52,72%
4	Retaining Walls	108,23 m <sup>3</sup>	Volume	2,09%	2,14%	-
5	Structural Foundations	144,87 m <sup>3</sup>	Volume	15,95%	15,42%	36,01%

Another result that comes from the building circularity report is that the material recovered which is demonstrated in the table 13. According to the landfilling for concrete, there are no value for reuse as material. Only floors as reinforced concrete material is reusable by downcycling 100%. The disposal possibility for columns, beams and retaining walls are less than 10%, while floors has 73,29% and foundation as reinforced concrete has 17,9%.

Table 13: Building Circularity Report of Recovered Material for Landfilling for Concrete Option

Materials Recovered						
#	Categories	Quantity (m3) in Total	Unit	Reuse as Material tons	Downcycling tons	Disposal tons
1	Columns	78,86 m3	Volume	-	-	6,47%
2	Beams	108,33 m3	Volume	-	-	3,34%
3	Floors	3348,31 m2	Area	-	%100	73,29%
4	Retaining Walls	108,23 m3	Volume	-	-	2,35%
5	Structural Foundations	144,87 m3	Volume	-	-	17,9%

As a result, for landfilling option caused different results than the other three options in the database of OneClickLCA program. The foundation as a component has 40%, 12% of columns, while 75% floors as recovered material. As returned materials, 16% of foundation, 2% of retaining walls, 6% of columns and 75% of floors came as a result. The disposal possibility according to the circularity report is 17% for foundation, while 74% of floor. The reason for this is the floor component for the study has greater volume than any other material or component. Also, the quality and usage of concrete is different than the structural elements. The report also shows that, only floor component of the building can be used as energy with downcycling as 100% value. The circularity percentage is the highest in floor component and secondly foundation component follows it with 17,12%. The steel bars were selected as to be separated in 2%, according to the selections in the building circularity tool calculations in OneClickLCA. The results for steel bars come up 100% of reusability, as it is valid for the other calculations.

The building circularity tool has many features, and many parameters to be filled in for broader investigations. The reinforced concrete as a material was only one material to be calculated in terms of sustainable usage for future applications. The following chapter will evaluate the results for the study and the usability factors of reinforced concrete material.

## **Chapter 5**

### **CONCLUSION**

It is widely believed that the building sector impacts significantly to environmental degradation (Lu and Yuan, 2011). Landfilling activities, and enormous amount of natural resources usage are amongst the reasons that construction actions cause according to the Environmental Protection Agency's data. The action of the industry leads to excessive amount of construction waste which needs to be reconsider for reuse and recycle options to achieve a more sustainable environment. Amongst all material that is used in construction sector, the most preferred and used material is concrete according to the study of Quedou in 2021. Likewise, reinforced concrete as a structural system is the most commonly used system in the world, specifically in the developing countries such as North Cyprus.

The concept of sustainable concrete comes up against the unfavorable actions of construction sector towards to the environment. The world started to consider sustainable solutions for concrete material to prevent the irrevocable actions of construction activities. Reusing reinforced concrete materials after its lifecycle, reusing the crushed aggregates of concrete for newly developing projects or infrastructure purposes are considered some of the ways to gain the concrete as a material for future uses in theory. In practice, it has many difficulties in terms of time, economical inefficiencies, and insufficient material specifications for reuse purposes.

The researchers and the companies around the world give importance to close the gaps for achieving more sustainable solutions for end-life scenarios of concrete material.

There are many tools that are developed for gathering information from conceptual design stage to end-of-life stage. Building information modelling ensures a working environment for architects, civil engineers, mechanical engineers, and electrical engineers to work together to develop a project. It allows add-in tools for analysis purposes such as life cycle assessment tools. The life cycle assessment tools such as OneClick LCA give opportunity to assess the current environmental effects on items or buildings throughout their life cycles. OneClick LCA is a program has many features including building circularity tool that works integrated with life cycle analysis. The Building Circularity tool provides monitoring, assessing, and managing the circularity of materials obtained and used throughout the building life-cycle as well as the circularity at the end of life. It enables for both a comprehensive overview and a thorough analysis by material kind. The program also encourages using the concepts of Design for Disassembly and Design for Adaptability. The aforementioned tool may be used for HQE Economie Circulaire, London Plan Circularity Statement, Ellen McArthur Foundation Circularity Indicators, as well as other circular design applications (oneclicklca platform, obtained June 2023).

The Building Circularity tool's objective is to figure out your building's or asset's circularity percentage. It has no set limitations and may be utilized to get access to either specific materials or whole structures. The report of building circularity for the selected case illustrates the whole material circularity, including management of end-of-life materials as well as the utilization of materials for the project. It can be defined as the average of "materials recovered," which indicates the project's usage of

recyclable materials, and "materials returned," which represents how effectively items are returned rather than disposed of or devalued. The computation does not weigh the materials; it is solely based on mass. According to the category "Material Returned," the percentages of reuse as material, recycling, downcycling, usage as energy, and disposal are provided. The mass-based sharing figures relate to materials that are either recycled or reused as materials, or, added with 50% of materials that are either down cycled with value loss, such as using recovered concrete as aggregate, or used as energy, such as burning wood or plastic products.

In this study, an extensive literature review gives the collected information which is given for clarifying the topics on reusability and recyclability assessment of reinforced concrete material by using Building Circularity tool with OneClickLCA program. The aim of this study is to indicate the process of building circularity study on reinforced concrete material. It also aims to use the building circularity tool by trying all parameters available for the reinforced concrete material to achieve the ultimate sustainable solution such as recycling or reusing the material at its end of life service. For many years, researchers were investigating the possible sustainable solutions for reinforced concrete, however achieving sustainable reinforced concrete is a complicated, time consuming and expensive process. The recent studies and developing technology give a new path by making it easier to use via programs. The main gap that is aiming to fill is finding an optimum sustainable solution for reinforced concrete material for a building that has reached to its end of life with the use of building circularity assessment tool and assess the reusability and/or recyclability potential for it to be able to use in future applications.

The building circularity assessment tool in One Click LCA program has a very user friendly interface with lots of explanation for easy usage. It does not serve special customer service for student licenses, however there are blogs and ready-made videos for questions to be asked for a correct usage. It definitely makes the sustainable thinking process easier and faster for the project developers and designers who are considering reusing to rebuilt with current materials. The selected office building for this study, which is the office building of EMU Faculty of Architecture, is more than 25 years of age and examined as structural elements, components, as reinforced concrete materials. The foundation, columns, beams, retaining walls as structural components and floor elements as concrete materials is included into the calculation for reusability and recyclability. It limits the study in terms of reusable and recyclable materials by eliminating steel, glass, brick and other elements and materials. It also limits the study by working on an office environment rather than residential, hospitality, healthcare, or any other facilities. The reason for selecting office building was to investigate a building which has a stable usage. Also, there are many buildings around the office building of Architecture Faculty that belong to other faculties which could be suggesting for future applications.

There are four different study done on the same building according to the parameters that differ with the selection of different end of life scenarios that building circularity tool suggests. The parameters are using EoL defined in EPD, crushing concrete into aggregate, reusing as material, and landfilling for concrete aggregates. According to the results obtained from all four calculations for different parameters of reinforced concrete material, it can be understood that the selection of landfilling option is the weakest solution which were already indicated in the literature review section. The

Environmental product declaration definition for end of life was another weak solution. The reason for that can be seen as the database selected for each material during material mapping. The limited materials that exist in the database of OneClickLCA is another factor that limits this study. The database is basically generated through the materials which exist in the Europe market where the program itself developed. Even though the material itself is a difficult task to recycle or reuse due to the formation and toxicity specification, the building circularity results of reusing as material and crushing into aggregates obtained as almost 30%. Considering the facts that reinforced concrete has steel bars and it is inseparable as material, it was calculated separately and added to the results.

As a result, the method in this study investigated from four different end of life scenarios of reinforced concrete material with building circularity tool. The circularity report gave results on components by defined as individual materials through the mapping system. Assessing the possibility of reusability and recyclability of reinforced concrete material with BIM integrated programs was mentioned as a gap in this study. Achieving the results out of this study tried to give a method to be used both in academic and professional world. For academic purposes, the study is open for more investigation. The materials can be either worked as individually or combined manner. It is possible to calculate the building circularity as the whole building with all materials included such as glass, brick, or steel or as components of the building such as walls, windows.

Another possible usage for the method would be for the professional work environment which could be directly integrated in the design stage for reconstructing projects. The materials that are going to be gained from the building to be

deconstructed would be used for the new project either for structural material phases, or infrastructure purposes by downcycling the materials according to the results obtained from building circularity report.

A strong, persistent, and permanent solution must be developed in light of the waste produced by building and demolition in emerging nations like Cyprus Island. A deeper grasp of rethinking, reducing, reusing, and recycling is essential for a sustainable future in light of this study.

## REFERENCES

- Abik, B. T., (2023). *Kentsel donusum nedeniyle ortaya cikan moloz atiklarinin geri donusturulmesi ile uretilen betonun yasam dongusu degerlendirmesi, Yuksek Lisans Tezi, G.U.*
- Abdulghani, G. R., & Gullu, A. (2021). Building information modelling (BIM): benefits for small scale construction industry. *International Journal of Engineering and Management Research*.
- Ajayi, S. O., Oyedele, L. O., Akinade, O. O., Bilal, M., Owolabi, H. O., & Alaka, H. A. (2014, December). Ineffectiveness of construction waste management strategies: Knowledge gap anaslysis. In *Okeil, M.(2014). Smart, sustainable and healthy city, Proceedings of the First International Conference of the CIB Middle East and North Africa Research Network (CIB-MENA 2014)* (pp. 261-280).
- Akanbi, L. A., Oyedele, L. O., Akinade, O. O., Ajayi, A. O., Delgado, M. D., Bilal, M., & Bello, S. A. (2018). Salvaging building materials in a circular economy: A BIM-based whole-life performance estimator. *Resources, Conservation and Recycling, 129*, 175-186.
- Akanbi, L., Oyedele, L., Davila Delgado, J. M., Bilal, M., Akinade, O., Ajayi, A., & Mohammed-Yakub, N. (2019). Reusability analytics tool for end-of-life assessment of building materials in a circular economy. *World Journal of Science, Technology and Sustainable Development, 16(1)*, 40-55.

- Akbarnezhad, A., Ong, K. C. G., & Chandra, L. R. (2014). Economic and environmental assessment of deconstruction strategies using building information modeling. *Automation in construction*, 37, 131-144.
- Akinade, O. O., Oyedele, L. O., Omotoso, K., Ajayi, S. O., Bilal, M., Owolabi, H. A., ... & Looney, J. H. (2017). BIM-based deconstruction tool: Towards essential functionalities. *International Journal of Sustainable Built Environment*, 6(1), 260-271.
- Akinade, O. O., Oyedele, L. O., Ajayi, S. O., Bilal, M., Alaka, H. A., Owolabi, H. A., & Arawomo, O. O. (2018). Designing out construction waste using BIM technology: Stakeholders' expectations for industry deployment. *Journal of cleaner production*, 180, 375-385.
- Alhamami, A., Petri, I., Rezgui, Y., & Kubicki, S. (2020). Promoting energy efficiency in the built environment through adapted bim training and education. *Energies*, 13(9), 2308.
- Antón, L. Á., & Díaz, J. (2014). Integration of life cycle assessment in a BIM environment. *Procedia Engineering*, 85, 26-32.
- Assi, L., Carter, K., Deaver, E. E., Anay, R., & Ziehl, P. (2018). Sustainable concrete: Building a greener future. *Journal of cleaner production*, 198, 1641-1651.
- Bakchan, A., Faust, K. M., & Leite, F. (2019). Seven-dimensional automated construction waste quantification and management framework: Integration with

project and site planning. *Resources, Conservation and Recycling*, 146, 462-474.

Bakker, C., Wang, F., Huisman, J., & Den Hollander, M. (2014). Products that go round: exploring product life extension through design. *Journal of cleaner Production*, 69, 10-16.

Bakx, M. J. M., Beurskens, P., Ritzen, M., Durmisevic, E., & Lichtenberg, J. J. N. (2016). A morphological design and evaluation model for the development of circular facades. *Sustainable Built Environment: Transition Zero*.

Beukers, J. (2022). Reuse of concrete structural elements in practice: Design of a tool which stimulates structural engineers to reuse concrete structural elements by giving insight in structural safety, environmental impact, and economic impact.

Bylund, C., & Magnusson, A. (2011). Model based cost estimations-an international comparison. *TVBP*.

Celikag, M., & Naimi, S. (2011). Building construction in North Cyprus: Problems and alternatives solutions. *Procedia Engineering*, 14, 2269-2275.

Cheng, J. C., & Ma, L. Y. (2013). A BIM-based system for demolition and renovation waste estimation and planning. *Waste management*, 33(6), 1539-1551.

- Cheng, J. C., Won, J., & Das, M. (2015, July). Construction and demolition waste management using BIM technology. In *23rd Ann. Conf. of the International Group for Lean Construction, Perth, Australia* (pp. 381-390).
- Cherubini, F., Bargigli, S., & Ulgiati, S. (2009). Life cycle assessment (LCA) of waste management strategies: Landfilling, sorting plant and incineration. *Energy*, *34*(12), 2116-2123.
- Christensen, T. H., Damgaard, A., Levis, J., Zhao, Y., Björklund, A., Arena, U., ... & Bisinella, V. (2020). Application of LCA modelling in integrated waste management. *Waste Management*, *118*, 313-322.
- Condotta, M., & Zatta, E. (2021). Reuse of building elements in the architectural practice and the European regulatory context: Inconsistencies and possible improvements. *Journal of Cleaner Production*, *318*, 128413.
- Coffetti, D., Crotti, E., Gazzaniga, G., Carrara, M., Pastore, T., & Coppola, L. (2022). Pathways towards sustainable concrete. *Cement and Concrete Research*, *154*, 106718.
- Crawford, R. H., Mathur, D., & Gerritsen, R. (2017). Barriers to improving the environmental performance of construction waste management in remote communities. *Procedia engineering*, *196*, 830-837.

- de Brito, J., & Kurda, R. (2021). The past and future of sustainable concrete: A critical review and new strategies on cement-based materials. *Journal of Cleaner Production*, 281, 123558.
- De Schepper, M., Van den Heede, P., Van Driessche, I., & De Belie, N. (2014). Life cycle assessment of completely recyclable concrete. *Materials*, 7(8), 6010-6027.
- Dutta, B. K., & Bandyopadhyay, S. (2010). Environmental impact assessment and social impact assessment-decision making tools for project appraisal in India. *International Journal of Human and Social Sciences*, 5(6), 350-355.
- Eionet Report, (2020). Construction and Demolition Waste: challenges and opportunities in a circular economy. ETC/WMGE 2020/1, <https://www.eionet.europa.eu/etcs/etc-wmge/products/etc-wmge-reports/construction-and-demolition-waste-challenges-and-opportunities-in-a-circular-economy>.
- Elmualim, A., & Alp, D. (2016). Perception and challenges for sustainable construction in developing countries: North Cyprus case. *Journal of Civil Engineering and Architecture*, 10(4), 492-500.
- European Environmental Agency (EEA), (1997). Life Cycle Assessment (LCA). A guide to approaches, experiences, and information sources. Environmental Issues Series, No.6. dk-TEKNIK Energy & Environment, Denmark.

European Environmental Agency (EEA), (2022). Buildings Renovation: where circular economy and climate meet.

European Environmental Agency (EEA), (2020). Construction and Demolition Waste: challenges and opportunities in a circular economy. Eionet Report – ETC/WMGE/2020/1

Eurostat, 2019a, Generation of waste by waste category, hazardousness and NACE Rev.2activity  
[https://appsso.eurostat.ec.europa.eu/nui/show.do?dataset=env\\_wasgen&lang=en](https://appsso.eurostat.ec.europa.eu/nui/show.do?dataset=env_wasgen&lang=en)

Flatt, R. J., Roussel, N., & Cheeseman, C. R. (2012). Concrete: An eco-material that needs to be improved. *Journal of the European Ceramic Society*, 32(11), 2787-2798.

Forth, K., Braun, A., & Borrmann, A. (2019, August). BIM-integrated LCA-model analysis and implementation for practice. In *IOP Conference Series: Earth and Environmental Science* (Vol. 323, No. 1, p. 012100). IOP Publishing.

Ganiron, T. U. (2015). Recycling concrete debris from construction and demolition waste. *International Journal of Advanced Science and Technology*, 77(7-24).

Ge, X. J., Livesey, P., Wang, J., Huang, S., He, X., & Zhang, C. (2017). Deconstruction waste management through 3d reconstruction and bim: a case study. *Visualization in engineering*, 5(1), 1-15.

- Gordon, M., Batallé, A., De Wolf, C., Sollazzo, A., Dubor, A., & Wang, T. (2023). Automating building element detection for deconstruction planning and material reuse: A case study. *Automation in Construction*, *146*, 104697.
- Guerra, B. C., Leite, F., & Faust, K. M. (2020). 4D-BIM to enhance construction waste reuse and recycle planning: Case studies on concrete and drywall waste streams. *Waste Management*, *116*, 79-90.
- Guerra, B. C., Bakchan, A., Leite, F., & Faust, K. M. (2019). BIM-based automated construction waste estimation algorithms: The case of concrete and drywall waste streams. *Waste Management*, *87*, 825-832.
- Hamid, S., Mat Isa, C. M., N Felix, S., & Mustaffa, N. K. (2020). Sustainable management using recycle and reuse of construction waste materials in Malaysia. *ESTEEM Academic Journal*, *16*, 47-58.
- Han, D., Kalantari, M., & Rajabifard, A. (2021). Building information modeling (BIM) for construction and demolition waste management in Australia: A research agenda. *Sustainability*, *13*(23), 12983.
- Han, G., & Srebric, J. (2011). Life-cycle assessment tools for building analysis. *Engr. Psu. Edu*, *7*.
- Hendriks, C. F., & Pietersen, H. S. (Eds.). (2000). *Report 22: SUSTAINABLE raw materials: construction and demolition waste—state-of-the-art report of RILEM technical committee 165-SRM* (Vol. 22). RILEM publications.

- Hollick, M. (1986). Environmental impact assessment: an international evaluation. *Environmental Management*, 10, 157-178.
- Hopkinson, P., Chen, H. M., Zhou, K., Wang, Y., & Lam, D. (2018, August). Recovery and reuse of structural products from end-of-life buildings. In *Proceedings of the institution of civil engineers-engineering sustainability* (Vol. 172, No. 3, pp. 119-128). Thomas Telford Ltd.
- Hossain, M. U., Wu, Z., & Poon, C. S. (2017). Comparative environmental evaluation of construction waste management through different waste sorting systems in Hong Kong. *Waste management*, 69, 325-335.
- Hu, M., Kleijn, R., Bozhilova-Kisheva, K. P., & Di Maio, F. (2013). An approach to LCSEA: the case of concrete recycling. *The International Journal of Life Cycle Assessment*, 18, 1793-1803.
- Huuhka, S., Kaasalainen, T., Hakanen, J. H., & Lahdensivu, J. (2015). Reusing concrete panels from buildings for building: Potential in Finnish 1970s mass housing. *Resources, Conservation and Recycling*, 101, 105-121.
- Iacovidou, E., Purnell, P., & Lim, M. K. (2018). The use of smart technologies in enabling construction components reuse: A viable method or a problem creating solution?. *Journal of environmental management*, 216, 214-223.

- Kang, K., Besklubova, S., Dai, Y., & Zhong, R. Y. (2022). Building demolition waste management through smart BIM: A case study in Hong Kong. *Waste Management, 143*, 69-83.
- Knoeri, C., Sanyé-Mengual, E., & Althaus, H. J. (2013). Comparative LCA of recycled and conventional concrete for structural applications. *The international journal of life cycle assessment, 18*, 909-918.
- Knoth, K., Fufa, S. M., & Seilskjær, E. (2022). Barriers, success factors, and perspectives for the reuse of construction products in Norway. *Journal of Cleaner Production, 337*, 130494.
- Krygiel, E., & Nies, B. (2008). *Green BIM: successful sustainable design with building information modeling*. John Wiley & Sons.
- Kumbhar, S., Gupta, A., & Desai, D. (2013). Recycling and reuse of construction and demolition waste for sustainable development. *OIDA International Journal of Sustainable Development, 6(7)*, 83-92.
- Kuiri, L., & Leardini, P. (2022). Adaptable and scalable housing for Australian households and stages of life. *ASA 2022*, 116.
- Küpfer, C., Bastien-Masse, M., & Fivet, C. (2022). Reuse of concrete components in new construction projects: critical review of 77 circular precedents. *Journal of Cleaner Production, 135235*.

- Kylili, A., Fokaides, P. A., Vaiciunas, J., & Seduikyte, L. (2015). Integration of building information modelling (BIM) and life cycle assessment (LCA) for sustainable constructions. *Journal of Sustainable Architecture and Civil Engineering*, 13(4), 28-38.
- Leising, E., Quist, J., & Bocken, N. (2018). Circular Economy in the building sector: Three cases and a collaboration tool. *Journal of Cleaner production*, 176, 976-989.
- Li, Z., Zhou, X., Ma, H., & Hou, D. (2022). *Advanced concrete technology*. John Wiley & Sons.
- Lu, W., & Yuan, H., (2011). A framework for understanding waste management studies in construction. *Waste management*, 31(6), 1252-1260.
- Masters, N. (2001). *Sustainable use of new and recycled materials in coastal and fluvial construction: a guidance manual*. Thomas Telford.
- Melton, P. (2020). Buildings that last: Design for adaptability, deconstruction, and reuse. *The American*.
- Menegaki, M., & Damigos, D. (2018). A review on current situation and challenges of construction and demolition waste management. *Current Opinion in Green and Sustainable Chemistry*, 13, 8-15.

- Monteiro, P. J., Miller, S. A., & Horvath, A. (2017). Towards sustainable concrete. *Nature materials*, *16*(7), 698-699.
- Morgan, R. K. (2012). Environmental impact assessment: the state of the art. *Impact assessment and project appraisal*, *30*(1), 5-14.
- Muñoz, S., Hosseini, M. R., & Crawford, R. H. (2022). Circular economy software tools at the material and product level: A scoping review. *ASA 2022*, 167.
- Naik, T. R. (2008). Sustainability of concrete construction. *Practice periodical on structural design and construction*, *13*(2), 98-103.
- Najjar, M., Figueiredo, K., Palumbo, M., & Haddad, A. (2017). Integration of BIM and LCA: Evaluating the environmental impacts of building materials at an early stage of designing a typical office building. *Journal of Building Engineering*, *14*, 115-126.
- Naneva, A., Bonanomi, M., Hollberg, A., Habert, G., & Hall, D. (2020). Integrated BIM-based LCA for the entire building process using an existing structure for cost estimation in the Swiss context. *Sustainability*, *12*(9), 3748.
- Neville, A. M., & Brooks, J. J. (1987). *Concrete technology* (Vol. 438). England: Longman Scientific & Technical.

- Nikmehr, B., Hosseini, M. R., Wang, J., Chileshe, N., & Rameezdeen, R. (2021). BIM-based tools for managing construction and demolition waste (CDW): A scoping review. *Sustainability*, *13*(15), 8427.
- Norouzi, M., Chàfer, M., Cabeza, L. F., Jiménez, L., & Boer, D. (2021). Circular economy in the building and construction sector: A scientific evolution analysis. *Journal of Building Engineering*, *44*, 102704.
- Oikonomou, N. D. (2005). Recycled concrete aggregates. *Cement and concrete composites*, *27*(2), 315-318.
- Ortolano, L., & Shepherd, A. (1995). Environmental impact assessment: challenges and opportunities. *Impact assessment*, *13*(1), 3-30.
- Osmani, M., Glass, J., & Price, A. D. (2008). Architects' perspectives on construction waste reduction by design. *Waste management*, *28*(7), 1147-1158.
- Oyenuga, A. A., Bhamidiarri, R., & Naoum, S. G. (2015). Challenges in Managing Construction and Demolition Waste. *Journal of Solid Waste Technology & Management*, *41*(4).
- Parekh, D. N., & Modhera, C. D. (2011). Assessment of recycled aggregate concrete. *Journal of engineering research and studies*, *2*(1), 1-9.
- Peng, C. L., Scorpio, D. E., & Kibert, C. J. (1997). Strategies for successful construction and demolition waste recycling operations. *Construction Management & Economics*, *15*(1), 49-58.

- Poon, C. S., Yu, A. T., Wong, A., & Yip, R. (2013). Quantifying the impact of construction waste charging scheme on construction waste management in Hong Kong. *Journal of construction engineering and management*, 139(5), 466-479.
- Ponnada, M. R., & Kameswari, P. (2015). Construction and demolition waste management—a review. *safety*, 84, 19-46.
- Quedou, P. G., Wirquin, E., & Bokhoree, C. (2021). A sustainable approach in using construction and demolition waste materials in concrete. *World Journal of Engineering*, 18(6), 826-840.
- Rajendran, P., & Gomez, C. P. (2012, June). Implementing BIM for waste minimisation in the construction industry: A literature review. In *2nd international conference on Management, Malaysia* (pp. 557-570).
- Ratum, A. P., Sachari, A., & Wahjudi, D. (2020). A Review on Circular Design Guideliness by Ideo and Ellen Macarthur Foundation. *e-Prosiding Pascasarjana ISBI Bandung*, 1(1).
- Reike, D., Vermeulen, W. J., & Witjes, S. (2018). The circular economy: new or refurbished as CE 3.0?—exploring controversies in the conceptualization of the circular economy through a focus on history and resource value retention options. *Resources, conservation and recycling*, 135, 246-264.

- Rios, F. C., Grau, D., & Chong, W. K. (2019). Reusing exterior wall framing systems: A cradle-to-cradle comparative life cycle assessment. *Waste management*, 94, 120-135.
- Safari, K., & AzariJafari, H. (2021). Challenges and opportunities for integrating BIM and LCA: Methodological choices and framework development. *Sustainable Cities and Society*, 67, 102728.
- Salgin, B., Akgün, A., Coşgun, N., & Agyekum, K. (2017). Construction waste reduction through BIM-based site management approach. *International Journal of Engineering Technologies IJET*, 3(3), 135-142.
- Sharma, A., Saxena, A., Sethi, M., & Shree, V. (2011). Life cycle assessment of buildings: a review. *Renewable and Sustainable Energy Reviews*, 15(1), 871-875.
- Struble, L., & Godfrey, J. (2004, May). How sustainable is concrete. In *International workshop on sustainable development and concrete technology* (pp. 201-211).
- Tam, V. W., & Tam, C. M. (2006). A review on the viable technology for construction waste recycling. *Resources, conservation, and recycling*, 47(3), 209-221.
- Tam, V. W., & Tam, C. M. (2006). Evaluations of existing waste recycling methods: a Hong Kong study. *Building and Environment*, 41(12), 1649-1660.

- Tam, V. W. (2011). Rate of reusable and recyclable waste in construction. *The open waste management journal*, 4(1).
- Taygun, G. T., & Balanlı, A. (2007). ANALYSIS OF THE MODELS FOR LIFE CYCLE ASSESSMENT OF THE BUILDING AND BUILDING PRODUCTS. *Environmental Engineering & Management Journal (EEMJ)*, 6(1).
- Tserng, H. P., Chou, C. M., & Chang, Y. T. (2021). The key strategies to implement circular economy in building projects—a case study of Taiwan. *Sustainability*, 13(2), 754.
- Tukker, A. (2000). Life cycle assessment as a tool in environmental impact assessment. *Environmental impact assessment review*, 20(4), 435-456.
- Tuhan Abik, B. (2023). Kentsel donusum nedeniyle ortaya cikan moloz atiklarinin geri donusturulmesi ile uretilen betonun yasam dongusu degerlendirmesi. Yuksek Lisans Tezi. Bolu Gazi Universitesi, Fen Bilimleri Enstitusu, Bolu.
- U.S. Environmental Protection Agency (EPA), (2018). Construction and Demolition Debris Generation in the United States, 2015. Office of Resource Conservation and Recovery. September 2018.
- Van Damme, H. (2018). Concrete material science: Past, present, and future innovations. *Cement and concrete research*, 112, 5-24.

- Vermeulen, W. J. V., Reike, D., & Witjes, S. (2018). Circular Economy 3.0: getting beyond the messy conceptualization of circularity and the 3R's, 4R's and more....
- Veselka, J., Nehasilová, M., Dvořáková, K., Ryklová, P., Volf, M., Růžička, J., & Lupíšek, A. (2020). Recommendations for Developing a BIM for the Purpose of LCA in Green Building Certifications. *Sustainability*, *12*(15), 6151.
- Vieira, D. R., Calmon, J. L., & Coelho, F. Z. (2016). Life cycle assessment (LCA) applied to the manufacturing of common and ecological concrete: A review. *Construction and Building Materials*, *124*, 656-666.
- Wang, R., & Zhang, Y. X. (2018). Recycling fresh concrete waste: A review. *Structural Concrete*, *19*(6), 1939-1955.
- Wetzel, E. M., & Thabet, W. Y. (2015). The use of a BIM-based framework to support safe facility management processes. *Automation in Construction*, *60*, 12-24.
- Won, J., & Cheng, J. C. (2017). Identifying potential opportunities of building information modeling for construction and demolition waste management and minimization. *Automation in Construction*, *79*, 3-18.
- Xia, B., Ding, T., & Xiao, J. (2020). Life cycle assessment of concrete structures with reuse and recycling strategies: A novel framework and case study. *Waste Management*, *105*, 268-278.

- Yean Yng Ling, F., & Song Anh Nguyen, D. (2013). Strategies for construction waste management in Ho Chi Minh city, Vietnam. *Built Environment Project and Asset Management*, 3(1), 141-156.
- Yigit, C. K., (2021). Analyzing the sustainability of primary schools' external walls within the scope of life cycle assessment in Turkey and developing new details for improving. Master of Science in Architecture Thesis, ITU.
- Zhai, J. (2020). BIM-based building circularity assessment from the early design stages.
- Zhang, C., Hu, M., Di Maio, F., Sprecher, B., Yang, X., & Tukker, A. (2022). An overview of the waste hierarchy framework for analyzing the circularity in construction and demolition waste management in Europe. *Science of the Total Environment*, 803, 149892.